

EG-1 PC-ENERGY DISSIPATOR (WITHOUT GRATE)
EG-1A PC-ENERGY DISSIPATOR (WITH GRATE)

1. CONCRETE STRENGTH 4000 PSI MINIMUM.
2. REINFORCING SHALL CONFORM TO A.S.T.M. A615, GRADE 40.
3. ALL UNITS SHALL BE FOR A 2:1 SLOPE UNLESS SPECIAL ORDERED.
4. DOWEL HOLES PROVIDED TO PREVENT SETTLEMENT OF ADJACENT CONCRETE.
5. DIMENSIONS SHOWN FOR CONCRETE THICKNESS ARE MINIMUM. ACTUAL MEASUREMENTS MAY VARY WITH MANUFACTURER'S TOLERANCES.

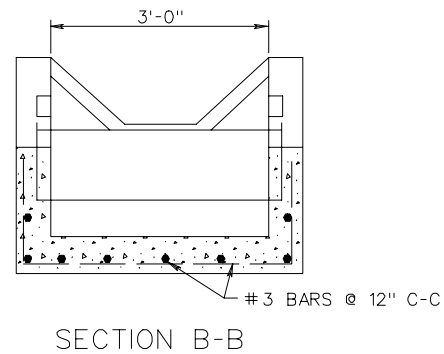
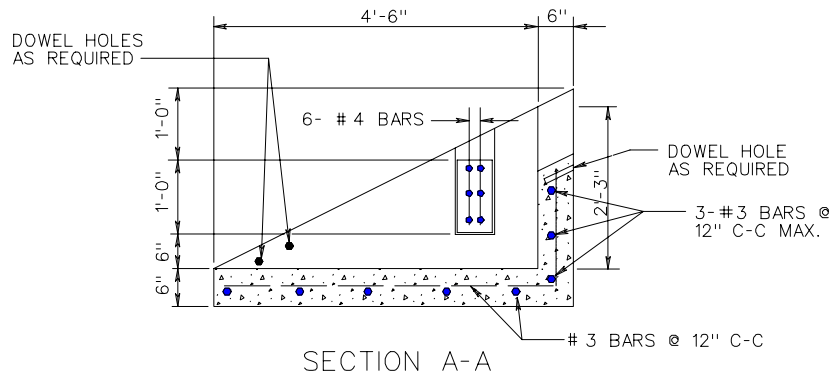

PRECAST ENERGY DISSIPATOR

VIRGINIA DEPARTMENT OF TRANSPORTATION

SPECIFICATION
REFERENCE

105