

PAVED SHOULDER SECTION

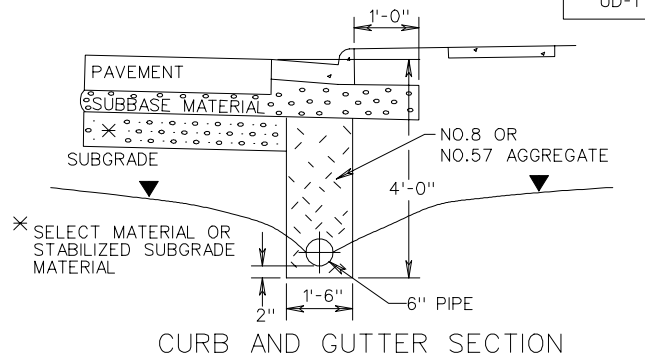

CURB AND GUTTER SECTION

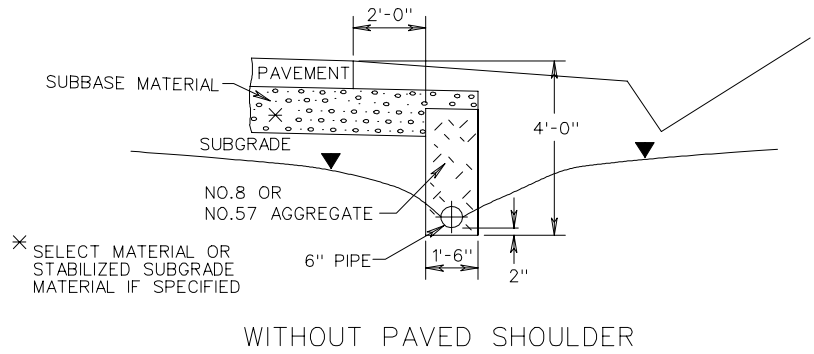

WITHOUT PAVED SHOULDER

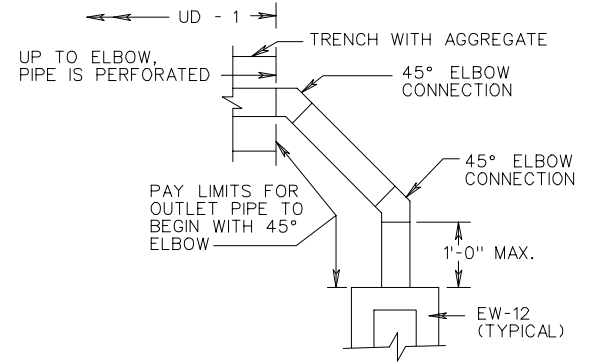

PLAN VIEW OF OUTLET PIPE AT FILL

LONGITUDINAL PERFORATED PIPE

TYPE OF PIPE	CRUSHING STRENGTH	
	W.T.	6" NOMINAL DIAMETER
SMOOTH WALL PVC	.153	
CORRUGATED PE		AASHTO M-252

NON-PERFORATED OUTLET PIPE

TYPE OF PIPE	CRUSHING STRENGTH	
	W.T.	6" NOMINAL DIAMETER
SMOOTH WALL PVC	.153	
SMOOTH WALL PE		70 PSI ***

✕ WALL THICKNESS (MIN) - INCHES
 ✕✕✕ TESTED ACCORDING TO ASTM D-2412 AT 5% DEFLECTION.

NOTES:

- WHERE THE LONGITUDINAL PERFORATED PIPE ALIGNS WITH A DRAINAGE STRUCTURE (DROP INLET, MANHOLE, ETC.), A NON-PERFORATED OUTLET PIPE IS NOT REQUIRED. INSTEAD, THE PERFORATED PIPE IS TO BE CONNECTED DIRECTLY TO THE DRAINAGE STRUCTURE. WHERE THE LONGITUDINAL PERFORATED PIPE IS CONTINUOUS, IT SHALL BE CONNECTED TO EACH SIDE OF THE DRAINAGE STRUCTURE.
- INVERT ELEVATION AT OUTLET END OF OUTLET PIPE TO BE A MINIMUM OF 1'-0" ABOVE INVERT ELEVATION OF RECEIVING DRAINAGE DITCH OR STRUCTURE.
- ALL CONNECTIONS (ELBOWS, WYES, ETC.) WITHIN PAY LIMITS FOR OUTLET PIPE ARE TO BE OF THE SAME CRUSHING STRENGTH AS THE OUTLET PIPE.
- OUTLET PIPE ARE TO BE INSTALLED ON 2% MIN. (3% DESIRABLE) GRADE.
- THE NORMAL DEPTH OF UNDERDRAIN IS TO BE 4'-0" BELOW THE NEAR EDGE OF PAVEMENT AS SHOWN. THE LONGITUDINAL GRADE OF THE UNDERDRAIN SHALL FOLLOW THAT OF THE ROADWAY WITH A MINIMUM GRADE OF 0.2 %
- WHERE THE BOTTOM OF SELECT MATERIAL IS GREATER THAN 4'-0" BELOW THE PAVEMENT, THE BOTTOM OF THE UNDERDRAIN IS TO BE COINCIDENT WITH THE BOTTOM OF SELECT MATERIAL AND THE TRENCH DEPTH AND BACKFILL QUANTITY INCREASED ACCORDINGLY.
- WHEN USED WITH STABILIZED OPEN-GRADED DRAINAGE LAYER, THE BOTTOM OF THE CURB AND GUTTER SHALL BE CONSTRUCTED PARALLEL TO THE SLOPE OF SUBBASE COURSES OUT TO THE DEPTH OF THE PAVEMENT.
- OUTLET PIPE TO BE SECURELY CONNECTED TO EW-12OR OTHER DRAINAGE STRUCTURE.
- ▼ DENOTES WATER TABLE.
- OUTLET PIPE CONFIGURATION TO PROVIDE FOR PASSAGE OF INSPECTION CAMERA WITH 2 1/2" I. D. HEAD.

SPECIFICATION REFERENCE
240
501
701

STANDARD GROUNDWATER UNDERDRAIN

VIRGINIA DEPARTMENT OF TRANSPORTATION