

LOCATION OF CHAMBER TO FIT VARIOUS FLOW LINE ANGLES

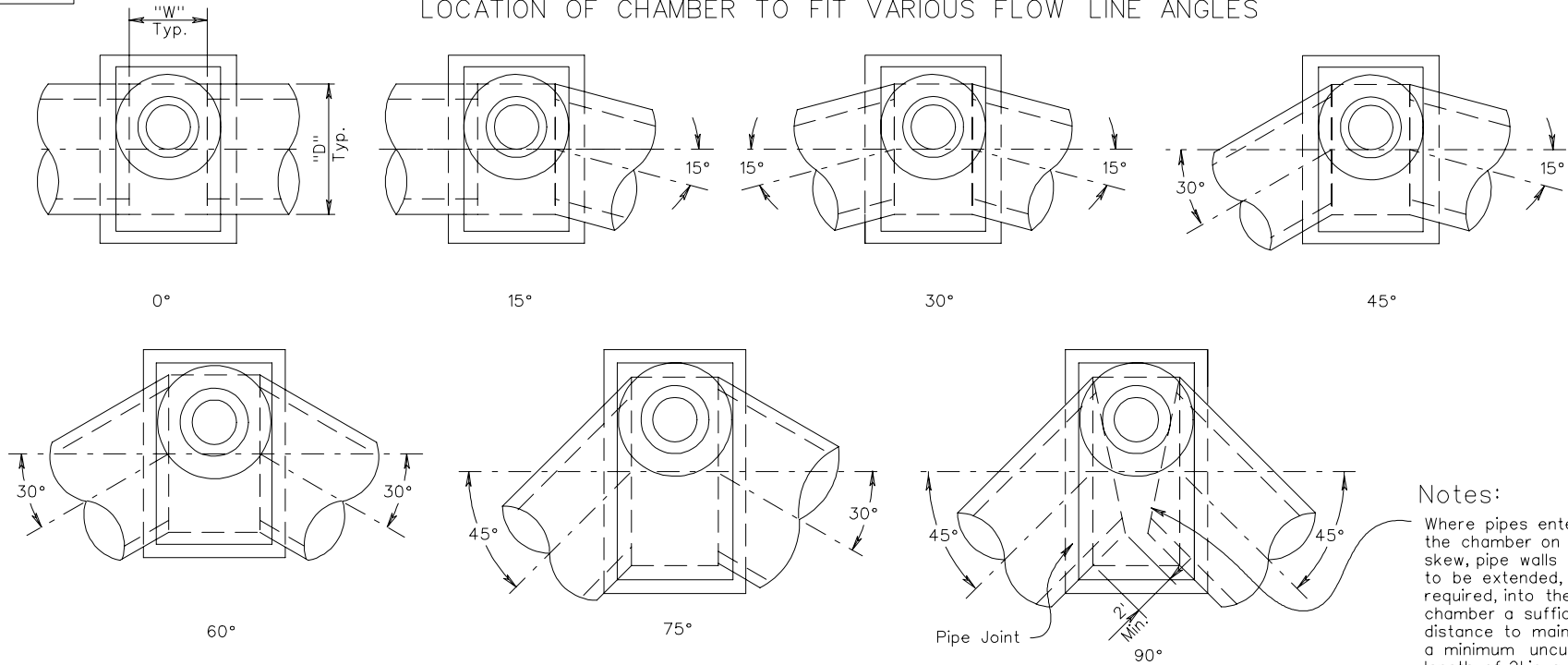

Notes:  
Where pipes enter the chamber on a skew, pipe walls are to be extended, if required, into the chamber a sufficient distance to maintain a minimum uncut length of 2' in a 6' pipe section.

QUANTITIES FOR CHAMBER \*

ANGLE OF TURN

PIPE SIZE	ANGLE OF TURN												
	0°			1° - 30°			31° - 60°			61° - 90°			
	DIM. D	CU. YDS. CONC.	LBS. REINF. STEEL	DIM. D	CU. YDS. CONC.	LBS. REINF. STEEL	DIM. D	CU. YDS. CONC.	LBS. REINF. STEEL	DIM. D	CU. YDS. CONC.	LBS. REINF. STEEL	
TYPE A "W" = 4'-0"	48"	4'-10"	4.56	1293	5'-0"	4.65	1317	5'-7"	4.99	1412	6'-10"	5.72	1602
	54"	5'-5"	5.16	1466	5'-7"	5.26	1558	6'-3"	5.10	1617	7'-8"	6.53	1798
	60"	6'-0"	5.80	1657	6'-3"	5.96	1794	6'-11"	6.38	1831	8'-6"	7.38	2064
	66"	6'-7"	6.46	2028	6'-10"	6.63	2069	7'-7"	7.12	2220	9'-4"	8.27	2510
	72"	7'-2"	7.77	2248	7'-5"	7.95	2306	8'-3"	8.56	2490	10'-2"	9.97	2843
TYPE B "W" = 3'-0"	48"	4'-10"	4.06	1149	5'-0"	4.15	1173	5'-7"	4.46	1274	6'-10"	5.12	1440
	54"	5'-5"	4.61	1308	5'-7"	4.70	1373	6'-3"	5.07	1452	7'-8"	5.85	1619
	60"	6'-0"	5.19	1487	6'-3"	5.33	1531	6'-11"	5.71	1651	8'-6"	6.63	1925
	66"	6'-7"	5.79	1815	6'-10"	5.94	1934	7'-7"	6.40	2058	9'-4"	7.45	2359
	72"	7'-2"	7.00	2020	7'-5"	7.17	2086	8'-3"	7.73	2264	10'-2"	9.03	2585
TYPE C "W" = 2'-0"	48"	4'-10"	3.53	1030	5'-0"	3.61	1052	5'-7"	3.88	1133	6'-10"	4.47	1294
	54"	5'-5"	4.02	1177	5'-7"	4.10	1236	6'-3"	4.43	1305	7'-8"	5.14	1454
	60"	6'-0"	4.54	1337	6'-3"	4.67	1381	6'-11"	5.02	1484	8'-6"	5.85	1710
	66"	6'-7"	5.09	1592	6'-10"	5.22	1674	7'-7"	5.64	1789	9'-4"	6.59	2062
	72"	7'-2"	6.19	1835	7'-5"	6.34	1885	8'-3"	6.86	2050	10'-2"	8.05	2355

\* Quantities shown are for chamber without pipes. Pipe displacement of concrete and steel must be deducted to obtain true quantities. See Sheet 4 of 4.

Chamber and tower quantities for concrete and reinforcing steel must be added to obtain totals.

"W"	STRUCT. STEEL
2'-0"	30 Lbs.
3'-0"	40 Lbs.
4'-0"	50 Lbs.

JUNCTION BOX DETAILS FOR ANGULAR CONNECTIONS OF 48" - 72" PIPE CULVERTS

SPECIFICATION REFERENCE

105  
233  
302