

T-D1-5

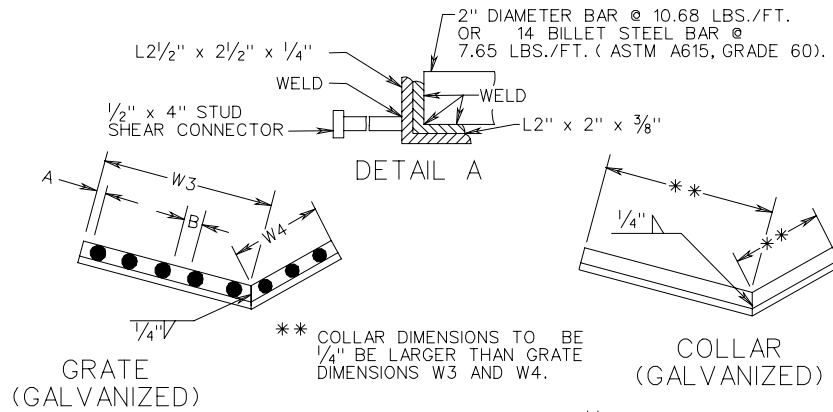
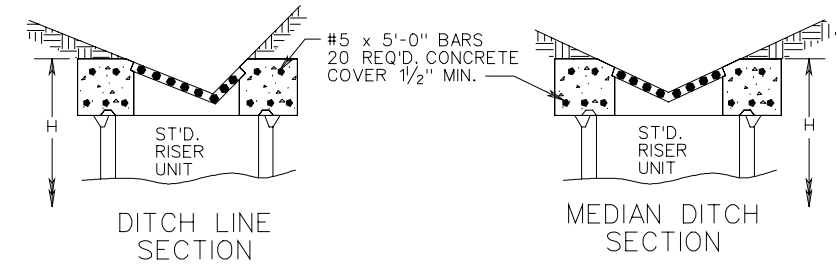
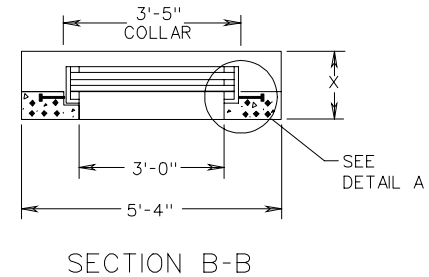
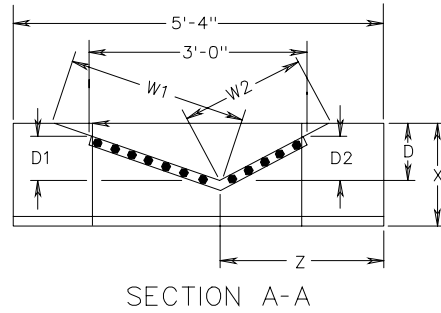
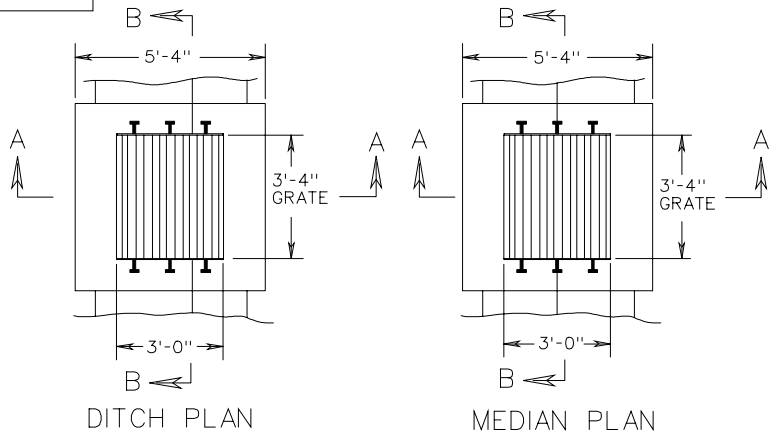

GRATE (GALVANIZED)

COLLAR (GALVANIZED)

\* TOLERANCE ± 1/2"

GRATE BAR SPACING CHART		
GRATE TYPE	MAXIMUM DIMENSION	
	a	b
A I	1 1/2"	3"
A III	1"	1"

ST'D PG-2 TYPE	COVER DIMENSIONS AND QUANTITIES								
	W1	W2	W3	W4	D*	D1	D2	X	Z
A1,A2,A3	3'-0 1/2"	2'-0 1/16"	2'-0 5/16"	1'-0 3/8"	6"	4"	3"	14"	2'-2"
B1,B2,B3,B4, C1,C2,C3	2'-9"	2'-9"	1'-6 9/16"	1'-6 9/16"	8"	4 1/2"	4 1/2"	16"	2'-8"
E	2'-3"	2'-3"	1'-8 1/16"	1'-8 1/16"	12"	9"	9"	19"	2'-8"

NOTES:

- SEE GENERAL NOTES-PRECAST FOR ADDITIONAL DETAILS.
- CONCRETE SHALL BE 4000 PSIMINIMUM.
- REINFORCING STEEL SHALL BE IN ACCORDANCE WITH ASTM-A 615.
- CONCRETE COVER AND GRATE ARE TO BE FURNISHED AS A SINGLE UNIT.
- DIMENSIONS SHOWN ARE MINIMUM. ACTUAL DIMENSIONS MAY VARY WITH MANUFACTURER.
- GRATE BARS ARE TO BE INSTALLED SO THEY WILL BE ALIGNED PARALLEL TO THE DITCH FLOW.
- WHERE DITCH SLOPES DO NOT MATCH THOSE OF INLET COVER, THE AREA ADJACENT TO THE INLET IS TO BE GRADED TO PROVIDE A SMOOTH TRANSITION.
- DI-5 IS TO BE UTILIZED IN LOCATIONS NOT NORMALLY SUBJECT TO TRAFFIC.

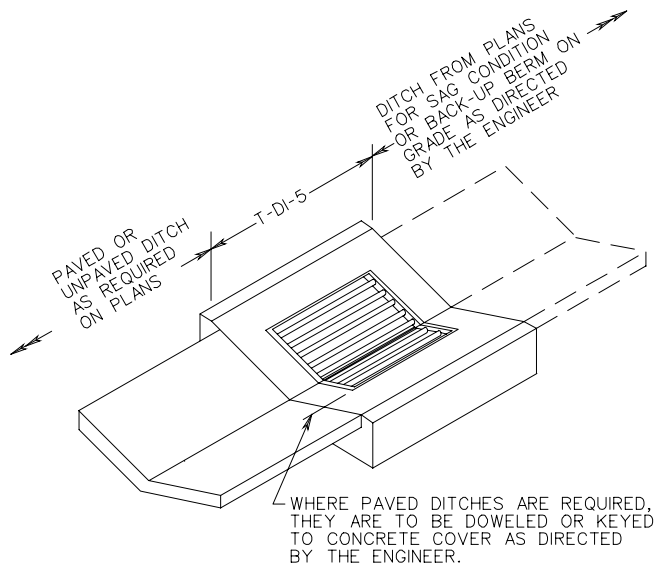

STANDARD PRECAST TOP UNITS

VIRGINIA DEPARTMENT OF TRANSPORTATION

SPECIFICATION REFERENCE

- 105
- 233
- 302

REV. 7/05  
103.07