

RECOMMENDED MINIMUM HEIGHT CHART	
PIPE SIZE	"H" DIMENSION (CONCRETE PIPE)
12"	4'-8"
15"	4'-11 1/4"
18"	5'-2 1/2"
21"	5'-5 3/4"
24"	5'-9"
27"	6'-0 1/4"
30"	6'-6 1/2"
33"	6'-9 3/4"
36"	7'-1"
42"	7'-7 1/2"
48"	8'-2"

NOTES

1. SEE GENERAL NOTES - PRECAST FOR ADDITIONAL DETAILS.
2. CONCRETE TO BE 4000 PSI MINIMUM.
3. REINFORCING STEEL IN ACCORDANCE WITH ASTM-615.
4. DIMENSIONS SHOWN ARE MINIMUM. ACTUAL DIMENSIONS MAY VARY WITH MANUFACTURER.
5. FOR DETAILS OF FRAME AND GRATE SEE STANDARD DI-2A, B, C.
- * 6. VERTICAL REINFORCING BARS TO BE CONTINUOUS THROUGH JOINT.
7. STANDARD ST-1 STEPS NOT REQUIRED IN THIS TOP UNIT.

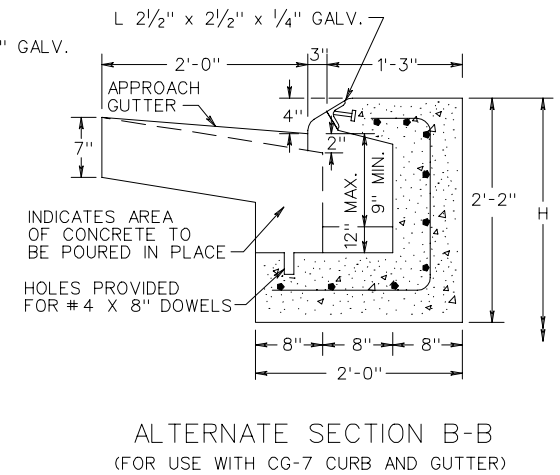
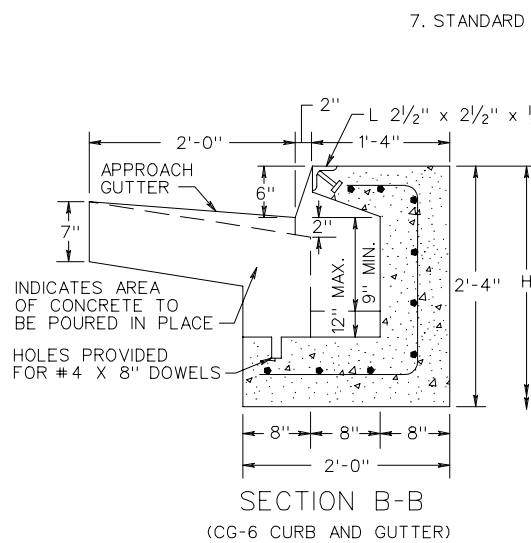
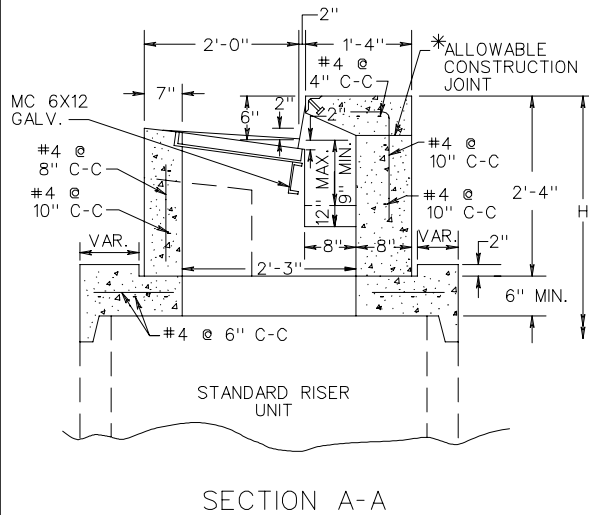

SPECIFICATION REFERENCE
105
233
302

STANDARD PRECAST TOP UNITS

VIRGINIA DEPARTMENT OF TRANSPORTATION

REV. 3/03

103.04