

PLAN VIEW

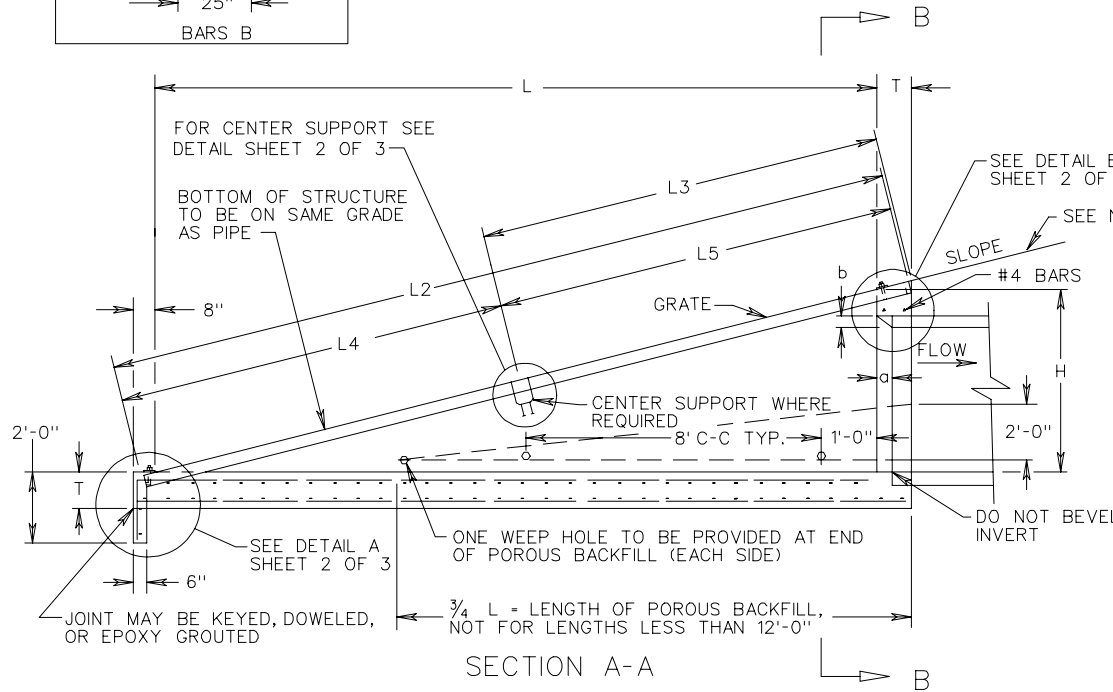

SECTION A-A

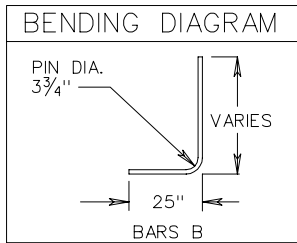
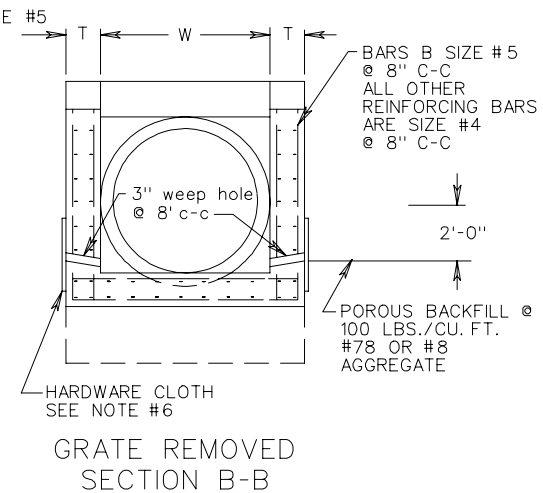

GRATE REMOVED SECTION B-B

NOTES:

1. THIS ITEM MAY BE PRECAST OR CAST IN PLACE. ALL CAST CONCRETE TO BE CLASS A3, FOR PRECAST USE 4000 PSI MINIMUM. REINFORCING STEEL TO HAVE A MINIMUM 1/2" COVER.
2. FOR TABULATION OF DIMENSIONS AND QUANTITIES SEE SHEET 3 OF 3.
3. ALL PIPE FOR GRATE, STRUCTURAL TUBING, AND RELATED HARDWARE TO BE GALVANIZED.
4. STANDARD EW-11 TO BE INSTALLED SO THE GRATE CONFIGURATION IS ALWAYS PERPENDICULAR TO THE EDGE OF THE SHOULDER.
5. SLOPE AS SPECIFIED ON TYPICAL SECTION.
6. WEEP HOLE WITH 12" X 12" PLASTIC HARDWARE CLOTH 1/4" MESH OR GALVANIZED STEEL WIRE, MINIMUM WIRE DIAMETER 0.03" NUMBER 4 MESH HARDWARE CLOTH ANCHORED FIRMLY OUTSIDE OF STRUCTURE.
7. HEADWALL TO BE BEVELED IN ALL AREAS EXCEPT WHERE A CONFLICT WITH INVERT OR WINGWALLS OCCUR.
8. BEVEL EDGE IS REQUIRED ON THE HEADWALL OF THE INLET END OF THE CULVERT (WHERE THE FLOW ENTERS THE CULVERT).
9. HEADWALL AT THE OUTLET END OF THE CULVERT MAY BE EITHER SQUARE EDGE OR BEVEL EDGE.
10. 3/4" CHAMFER MAY BE PROVIDED ON ALL EDGES AT MANUFACTURER'S OPTION.

PIPE ENDWALL WITH LOAD-CARRYING GRATE  
FOR 12"-60" PIPES  
VIRGINIA DEPARTMENT OF TRANSPORTATION

SPECIFICATION REFERENCE
105
233
302