

PLAN VIEW

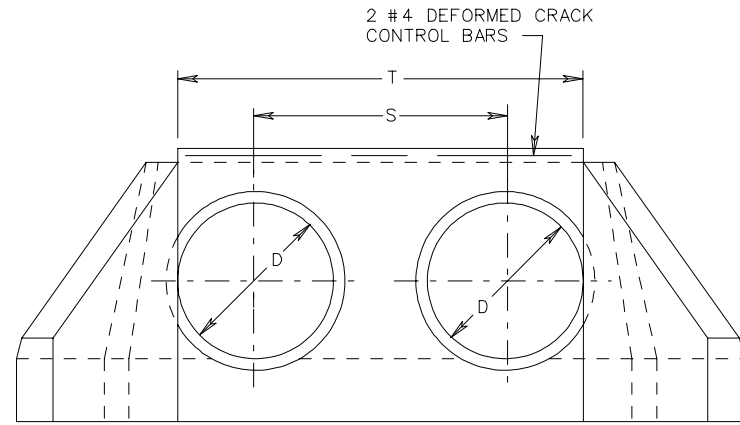

FRONT VIEW

NOTES:

1. QUANTITIES GIVEN ARE FOR ONE ENDWALL.
2. PLEASE REFER TO STANDARD EW-2, SHEET 101.04, FOR ALL DIMENSIONS NOT GIVEN IN TABLES.
3. THIS ITEM MAY BE PRECAST OR CAST IN PLACE.
4. ON SHALLOW FILLS, WHERE ENDWALLS ARE 1' OR LESS BELOW SHOULDER LINE, THE TOP OF THE ENDWALL SHALL BE CONSTRUCTED PARALLEL TO THE GRADE OF ROAD.
5. ALL CAST IN PLACE CONCRETE TO BE CLASS A3. FOR PRECAST SEE SHEET 101.18.
6. IN NO CASE SHALL TOP OF ENDWALL PROJECT ABOVE FILL SLOPE, DITCH SLOPE, OR SHOULDER.
7. THIS STANDARD TO BE USED WITH STRAIGHT CROSSINGS AND SKEW ANGLES TO 15°.
8. COST OF BARS FOR CRACK CONTROL TO BE INCLUDED IN PRICE PER BID PER CUBIC YARD CONCRETE.
9. HEADWALL TO BE BEVELED IN ALL AREAS EXCEPT WHERE A CONFLICT WITH INVERT AND WINGWALLS OCCUR.
10. BEVEL EDGE IS REQUIRED ON THE HEADWALL AT THE INLET END OF THE CULVERT (WHERE THE FLOW ENTERS THE CULVERT). HEADWALL AT THE OUTLET END OF THE CULVERT MAY BE EITHER SQUARE EDGE OR BEVEL EDGE.
11. 3/4" CHAMFER MAY BE PROVIDED ON ALL EDGES AT MANUFACTURER'S OPTION.

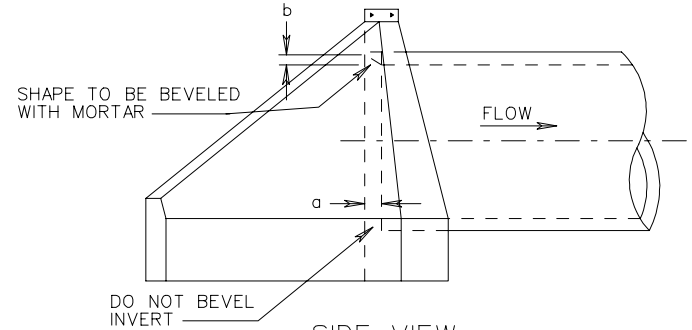

SIDE VIEW

| FOR CONCRETE PIPE | | | | | | | | | |
|-------------------|---------|---------|---------------------------------------|--|---------------------------------------|--|-----------|-----------|--|
| D | S | T | FILL SLOPE 1/2:1 | | FILL SLOPE 2:1 | | a | b | |
| | | | CONCRETE ONE DBL. ENDWALL CUBIC YARDS | INCREASE FOR EACH ADDITIONAL PIPE CUBIC YDS. | CONCRETE ONE DBL. ENDWALL CUBIC YARDS | INCREASE FOR EACH ADDITIONAL PIPE CUBIC YDS. | | | |
| 42" | 6'-0" | 9'-6" | 4.829 | 1.271 | 5.493 | 1.255 | 0'-4 1/2" | 0'-3 1/2" | |
| 48" | 6'-10" | 10'-10" | 5.964 | 1.591 | 6.802 | 1.572 | 0'-5" | 0'-4" | |
| 54" | 7'-8" | 12'-2" | 7.692 | 2.057 | 8.796 | 2.035 | 0'-5 3/4" | 0'-4 1/2" | |
| 60" | 8'-6" | 13'-6" | 9.689 | 2.600 | 11.112 | 2.574 | 0'-6 1/4" | 0'-5" | |
| 66" | 9'-4" | 14'-10" | 12.016 | 3.240 | 13.811 | 3.209 | 0'-7" | 0'-5 1/2" | |
| 72" | 10'-2" | 16'-2" | 14.663 | 3.961 | 16.885 | 3.927 | 0'-7 1/2" | 0'-6" | |
| 78" | 11'-0" | 17'-6" | 17.612 | 4.751 | 20.325 | 4.713 | 0'-8 1/4" | 0'-6 1/2" | |
| 84" | 11'-10" | 18'-10" | 21.148 | 5.696 | 24.387 | 5.617 | 0'-8 3/4" | 0'-7" | |
| 90" | 12'-8" | 20'-2" | 25.115 | 6.920 | 28.976 | 6.872 | 0'-9 1/2" | 0'-7 1/2" | |
| 96" | 13'-6" | 21'-6" | 29.439 | 8.153 | 33.999 | 8.101 | 0'-10" | 0'-8" | |

| FOR CORRUGATED METAL PIPE | | | | | | | | | |
|---------------------------|------------|------------|---------------------------------------|--|---------------------------------------|--|-----------|-----------|--|
| D | S | T | FILL SLOPE 1/2:1 | | FILL SLOPE 2:1 | | a | b | |
| | | | CONCRETE ONE DBL. ENDWALL CUBIC YARDS | INCREASE FOR EACH ADDITIONAL PIPE CUBIC YDS. | CONCRETE ONE DBL. ENDWALL CUBIC YARDS | INCREASE FOR EACH ADDITIONAL PIPE CUBIC YDS. | | | |
| 42" | 5'-3 1/2" | 8'-9 1/2" | 5.070 | 1.279 | 5.732 | 1.263 | 0'-4 1/2" | 0'-3 1/2" | |
| 48" | 6'-0 1/2" | 10'-0 1/2" | 6.296 | 1.616 | 7.132 | 1.596 | 0'-5" | 0'-4" | |
| 54" | 6'-9 1/2" | 11'-3 1/2" | 8.228 | 2.104 | 9.258 | 2.081 | 0'-5 3/4" | 0'-4 1/2" | |
| 60" | 7'-6 1/2" | 12'-6 1/2" | 10.319 | 2.677 | 11.738 | 2.650 | 0'-6 1/4" | 0'-5" | |
| 66" | 8'-3 1/2" | 13'-9 1/2" | 12.751 | 3.261 | 14.543 | 3.231 | 0'-7" | 0'-5 1/2" | |
| 72" | 9'-0 1/2" | 15'-0 1/2" | 15.673 | 4.068 | 17.889 | 4.033 | 0'-7 1/2" | 0'-6" | |
| 78" | 9'-9 1/2" | 16'-3 1/2" | 18.918 | 4.934 | 21.623 | 4.893 | 0'-8 1/4" | 0'-6 1/2" | |
| 84" | 10'-6 1/2" | 17'-6 1/2" | 22.733 | 5.905 | 25.999 | 5.860 | 0'-8 3/4" | 0'-7" | |
| 90" | 11'-3 1/2" | 18'-9 1/2" | 26.800 | 7.076 | 30.643 | 7.025 | 0'-9 1/2" | 0'-7 1/2" | |
| 96" | 12'-0 1/2" | 20'-0 1/2" | 31.460 | 8.353 | 36.000 | 8.296 | 0'-10" | 0'-8" | |

| |
|-------------------------|
| SPECIFICATION REFERENCE |
| 105 302 |

STANDARD ENDWALLS FOR MULTIPLE PIPE CULVERTS
42"-96" PIPE

VIRGINIA DEPARTMENT OF TRANSPORTATION