

NOTES:

1. FOR TABLE OF DIMENSIONS AND VOLUMES FOR CIRCULAR PIPES (STANDARD EW-2) SEE SHEET 2 OF 3.
2. FOR TABLE OF DIMENSIONS AND VOLUMES FOR ELLIPTICAL PIPES (STANDARD EW-2A) SEE SHEET 3 OF 3.
3. THIS ITEM MAY BE PRECAST OR CAST IN PLACE.
4. ON SHALLOW FILLS, WHERE ENDWALLS ARE 1' OR LESS BELOW SHOULDER LINE, THE TOP OF THE ENDWALL SHALL BE CONSTRUCTED PARALLEL TO THE GRADE OF ROAD.
5. ALL CAST IN PLACE CONCRETE TO BE CLASS A3. FOR PRECAST SEE SHEETS 101.06 AND 101.07.
6. IN NO CASE SHALL TOP OF ENDWALL PROJECT ABOVE FILL SLOPE, DITCH SLOPE, OR SHOULDER.
7. THIS STANDARD TO BE USED WITH STRAIGHT CROSSINGS AND SKEW ANGLES TO 15°.
8. COST OF BARS FOR CRACK CONTROL TO BE INCLUDED IN PRICE PER BID PER CUBIC YARD CONCRETE.
9. HEADWALL TO BE BEVELED IN ALL AREAS EXCEPT WHERE A CONFLICT WITH INVERT AND WINGWALLS OCCUR.
10. BEVEL EDGE IS REQUIRED ON THE HEADWALL AT THE INLET END OF THE CULVERT (WHERE THE FLOW ENTERS THE CULVERT). HEADWALL AT THE OUTLET END OF THE CULVERT MAY BE EITHER SQUARE EDGE OR BEVEL EDGE.
11. 3/4" CHAMFER MAY BE PROVIDED ON ALL EDGES AT MANUFACTURER'S OPTION.

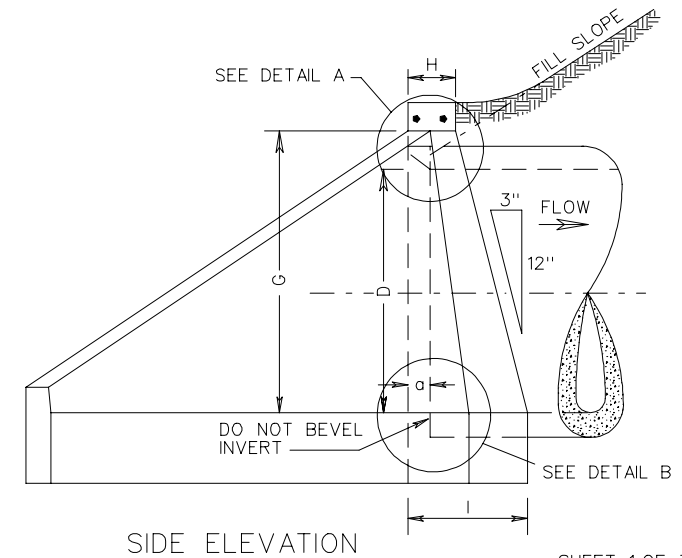
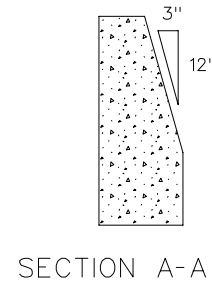
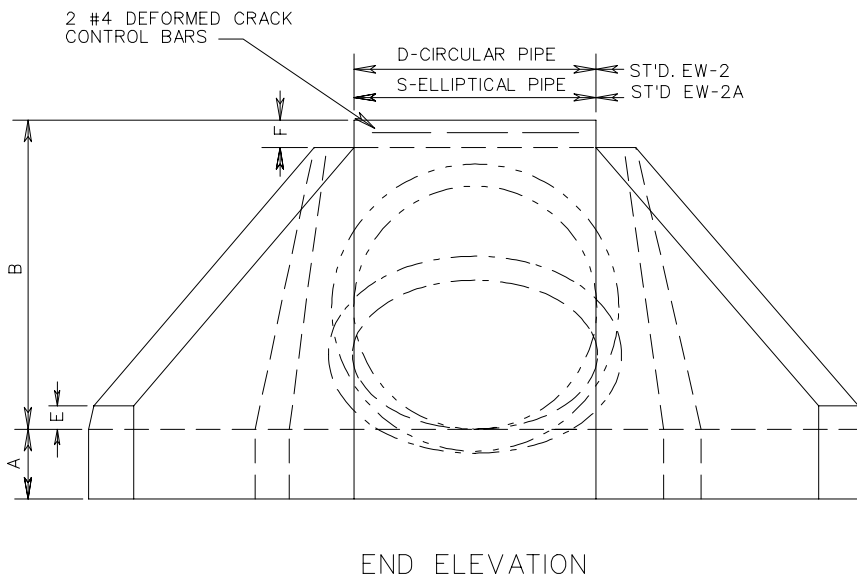

SPECIFICATION REFERENCE
105 302

STANDARD ENDWALL FOR PIPE CULVERTS
 42"-96" CIRCULAR AND 60"x38"-106"x68" ELLIPTICAL PIPES

VIRGINIA DEPARTMENT OF TRANSPORTATION