

SIZE (DIA. - INCHES)	4"	6"	8"	10"	12"	16"	18"	20"	24"
LENGTH ("L" - FEET)	12'	17'	22'	26'	31'	39'	43'	47'	55'

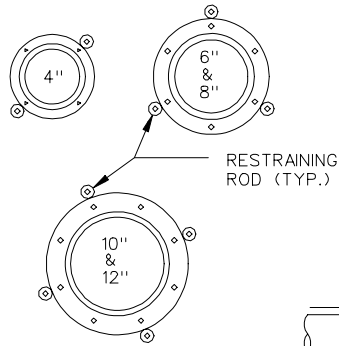

RESTRAINING ROD (TYP.)

SEE TABLE FOR 16" - 24"

TABLE		
PIPE SIZE	NUMBER OF BOLTS	NUMBER OF RODS
16"	12	6
18"	12	6
20"	14	6
24"	16	8

SEE NOTE 7 FOR REDUCTION IN NUMBER OF RODS REQUIRED.

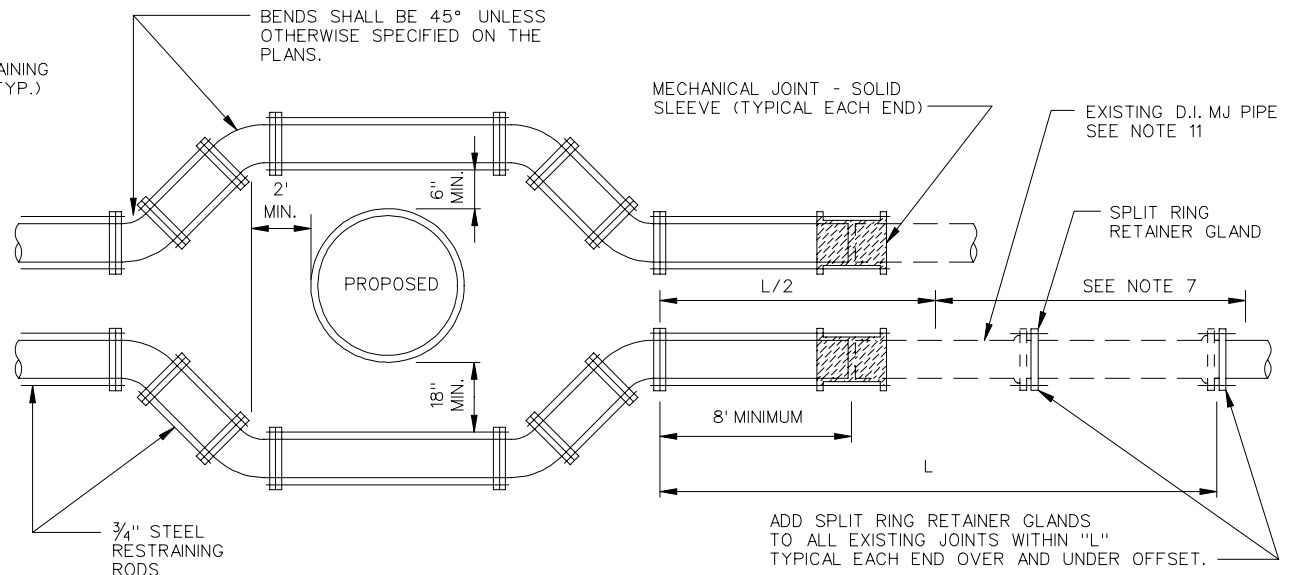

ADD SPLIT RING RETAINER GLANDS TO ALL EXISTING JOINTS WITHIN "L" TYPICAL EACH END OVER AND UNDER OFFSET.

DESIGN CONDITIONS

PRESSURE - 150 PSI      TYPE SOIL - SILT  
 DEPTH OF COVER - 3 FEET      ROD STRESS - 25,000 PSI

NOTES:

1. RETAINER GLANDS ARE REQUIRED AT EACH FITTING.
2. ALL PIPE AND FITTINGS SHALL BE DUCTILE IRON, MECHANICAL JOINT, CLASS 52 (MIN). WATER MAIN AND FITTINGS SHALL BE CEMENT MORTAR LINED.
3. FOR 12" AND SMALLER LINES, MECHANICAL JOINT OFFSET FITTINGS MAY BE USED IN LIEU OF THE 45° BENDS SHOWN SUBJECT TO THE APPROVAL OF THE ENGINEER. IF USED, THE OFFSETS MUST RESULT IN THE CLEARANCES SHOWN BEING MET OR EXCEEDED.
4. RODS MAY BE INSERTED THROUGH BOLT HOLES IN LIEU OF USING TIE-BOLTS. IF USED, KEEPER NUT & WASHER MUST BE INSTALLED BEHIND GLAND.
5. BOLT HOLES ARE SHOWN AS NORMALLY PROVIDED IN MECHANICAL JOINT FITTINGS, I.E. STRADDLING THE VERTICAL AXIS WHEN FITTING IS POSITIONED FOR A HORIZONTAL CHANGE OF DIRECTION. FITTINGS WITH BOLT HOLES OTHERWISE ORIENTED SHOULD NOT BE USED IN RODDED ASSEMBLIES.
6. TIE BOLTS AND THREADED RODS SHALL BE 3/4" WITH A MINIMUM YIELD STRENGTH OF 7550 POUNDS EACH. SPACE SYMMETRICALLY AROUND PIPE.
7. NUMBER OF RODS MAY BE REDUCED TO 50% OF THE NUMBER INDICATED AT L/2 FROM THE BEND AND BEYOND. TWO RODS MINIMUM REQUIRED PER JOINT.
8. ALL RODS AND FASTENERS SHALL BE GIVEN TWO COATS OF ASPHALTIC PAINT AFTER ASSEMBLY.
9. EXISTING C.I. PIPE SHALL BE REPLACED WITH AN 8' MINIMUM LENGTH OF D.I. PIPE AT BOTH ENDS OF THE OFFSET AND RETAINER GLANDS INSTALLED.
10. THE EXISTING PIPING SHALL HAVE ALL JOINTS WITHIN THE LENGTH "L" RESTRAINED BY ADDING A SPLIT RING RETAINER GLAND ("MEG-A-LUG" OR EQUAL) WITH BOLTS TO THE M.J. BELL.
11. LENGTH "L" IN FEET SHALL CONFORM TO THE TABLE ABOVE.
12. SPLIT RING RETAINER GLANDS ARE FOR USE ON DUCTILE IRON MECHANICAL JOINT PIPE ONLY. IF EXISTING PIPE IS ANY OTHER MATERIAL, REMOVE AND REPLACE WITH D.I. MECHANICAL JOINT PIPE FOR THE LENGTH "L" SPECIFIED.

# VERTICAL OFFSET WATER AND SANITARY SEWER FACILITIES