

Spacers shall be installed between the eyelet of the hanger assembly and the inside of the span wire clamp to eliminate any gap.

A waterproof sealant shall be applied to the thread area above the pipe coupling before the lock nut is screwed down.

Weatherhead signal hanger, steel leveling pipe and threaded pipe coupling shall be galvanized or painted flat black or yellow.

SIDE VIEW

Note:

Signalheads mounted on the same span wire shall be installed so the bottom sections are on a level plane or no greater than 12" above the bottom of the lowest signalhead.

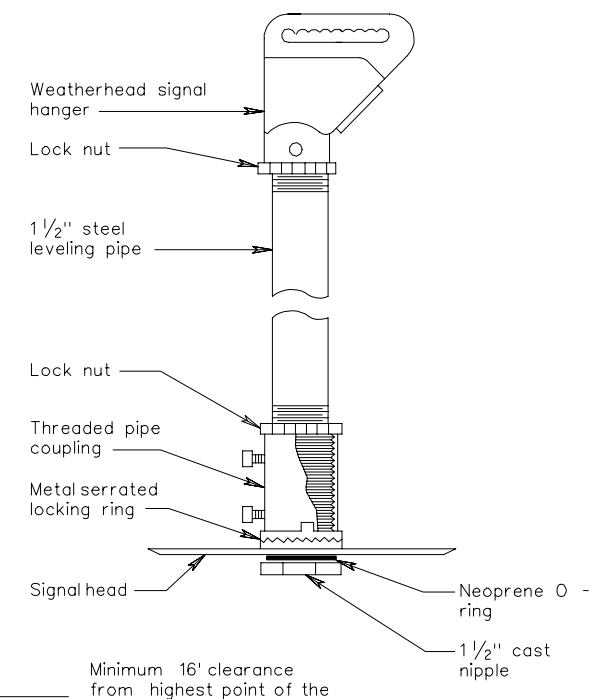
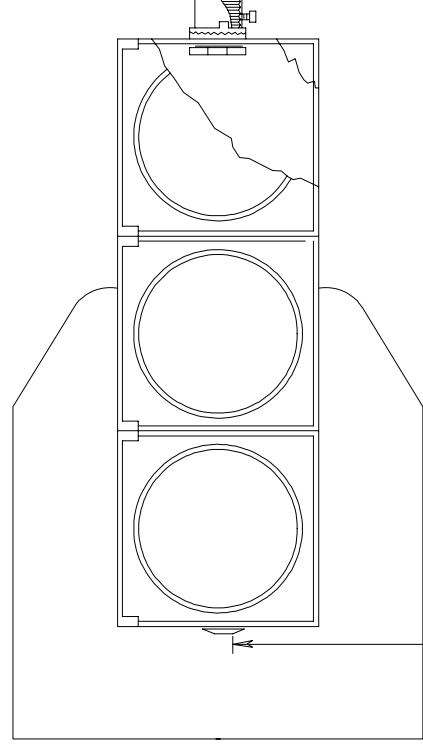

Minimum 16' clearance from highest point of the pavement surface to the lowest point of signal head assembly including backplate and tether clamp (includes signal heads on bridle span).

Signal head cables shall be continuous from the controller to the nearest signal head to which it applies except cable terminations may be allowed on the pole terminal strip when required by the plans. The cable shall also be continuous from the first signal head to any additional heads with termination on the terminals within the signal head housing.

SIGNAL HEAD MOUNTING DETAILS SPAN WIRE