

SECTION THRU RAIL ELEMENT AND W BEAM BACK-UP PLATE

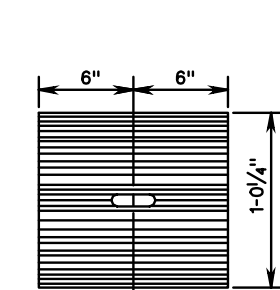

W BEAM BACK-UP PLATE

FOR USE AT NON SPLICE LOCATIONS.  
TO BE USED WITH STEEL W6 x 9 OR W6 x 8.5 BLOCKOUT ONLY.

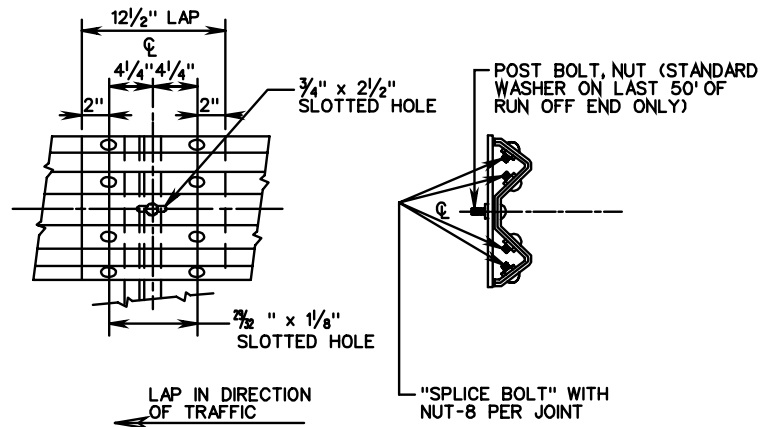

DETAIL OF SPLICE JOINT

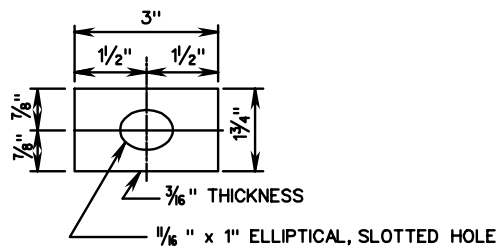

DETAIL OF STANDARD WASHER

FOR GR-2 AND 2A, MB-3  
TO BE USED ON THE LAST  
50' OF RUN OFF ENDS ONLY.

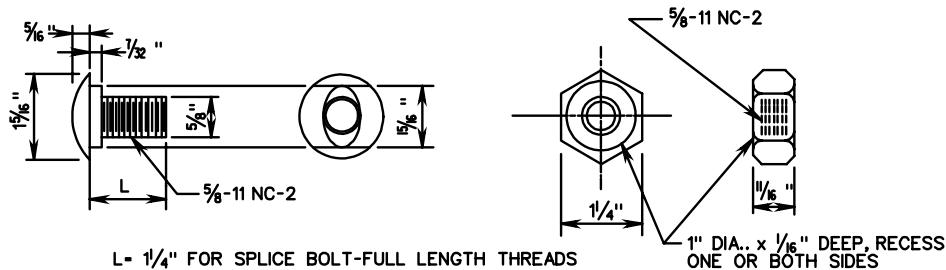

- L = 1/4" FOR SPLICE BOLT-FULL LENGTH THREADS
- L = 2" FOR STEEL POST BOLT-1/2" MIN. THREADS
- L = 18" FOR WOOD AND CONCRETE POST BOLT-2 1/2" MIN. THREADS
- L = 26" FOR MB WOOD OR CONCRETE POST-2" MIN. THREADS

DETAIL OF BUTTON HEAD BOLT AND RECESS NUT

NOTES:

ALL HARDWARE IS TO BE GALVANIZED IN ACCORDANCE WITH THE SPECIFICATIONS.

THE GUARDRAIL AND MEDIAN BARRIER COMPONENTS DEPICTED IN ARTBA TECHNICAL BULLETIN NUMBER 268B MAY BE SUBSTITUTED IF INTERCHANGEABLE WITH THE STANDARDS FOR GUARDRAIL (GR) OR MEDIAN BARRIER (MB) AND APPROVED BY THE ENGINEER.

STANDARD GUARDRAIL HARDWARE

VIRGINIA DEPARTMENT OF TRANSPORTATION

SPECIFICATION  
REFERENCE

221  
505