

The spacing between sign posts shall be a minimum of 8' center to center.  
 \* Signs shall be located to provide optimum viewing and safety within the indicated view limits for lateral placement.

\*\* In cut slopes, the minimum clearance between the bottom of the sign and the ground shall be 7' for any portion of the sign within the clear zone. This requirement will not apply to signs or portions of signs located more than 10' up a slope greater than 3:1.

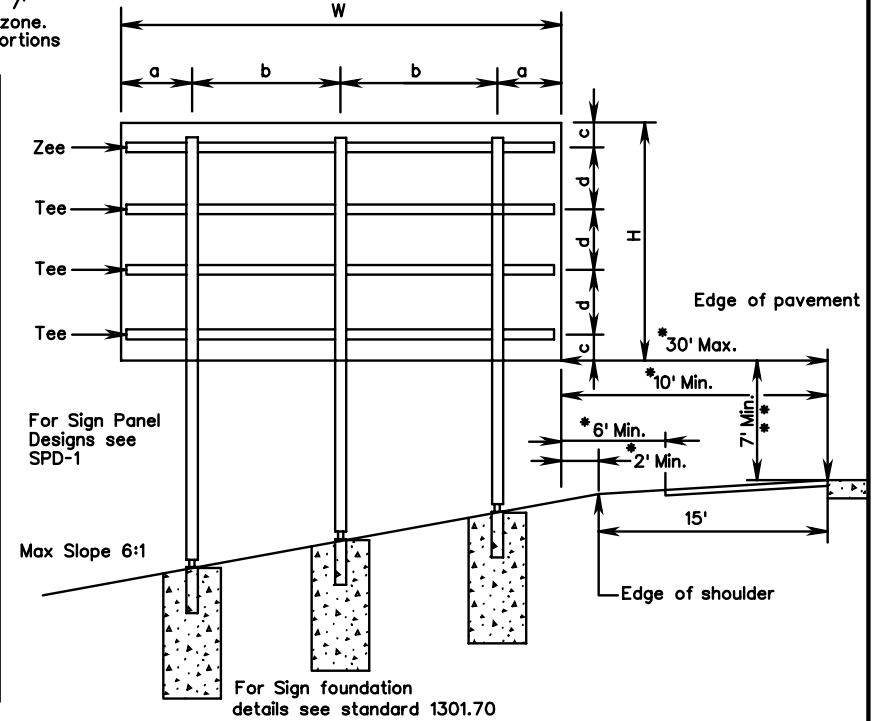

ISOMETRIC VIEW

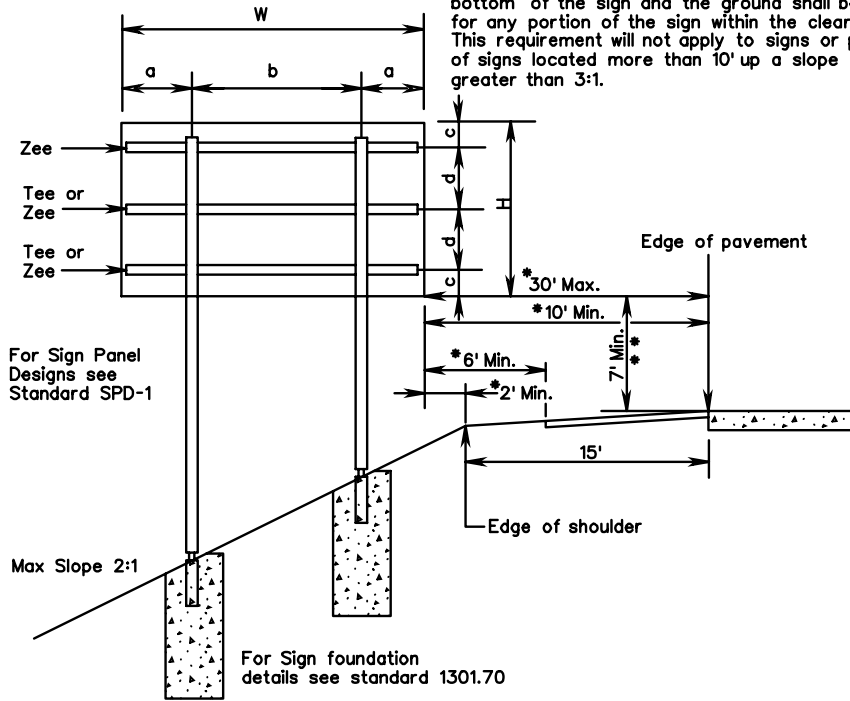
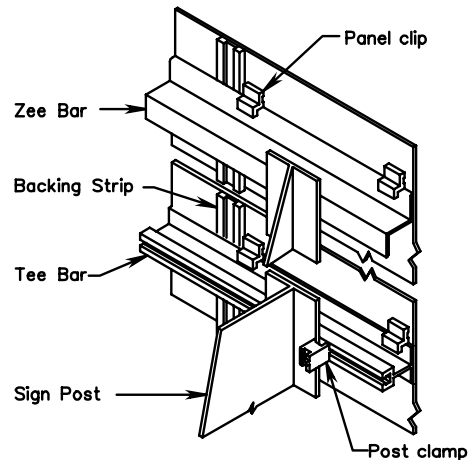

SHIM DETAIL

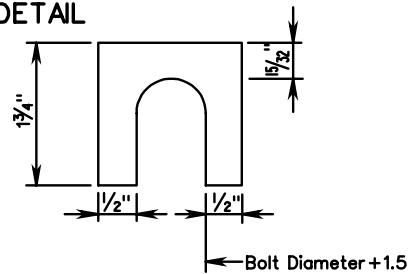

Furnish 2 each .063"± and 2 each .032± mm thick shims per pole. Shims shall be fabricated from brass conforming to ASTM B36 or from stainless steel with a minimum chromium content of 11.50 % . No more than 2 shims shall be used per bolt with a maximum of 4 shims per pole.

STIFFENER PLATE DETAIL

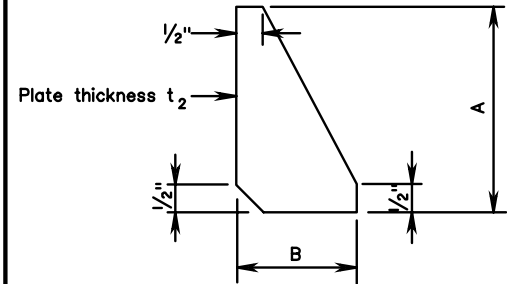

TYPICAL DETAILS FOR TYPE VIA INTERSTATE SIGN STRUCTURE