

**SILT BARRIERS
TYPICAL DETAIL FOR BRUSH BARRIER
(TO BE USED AT ALL APPLICABLE LOCATIONS)**

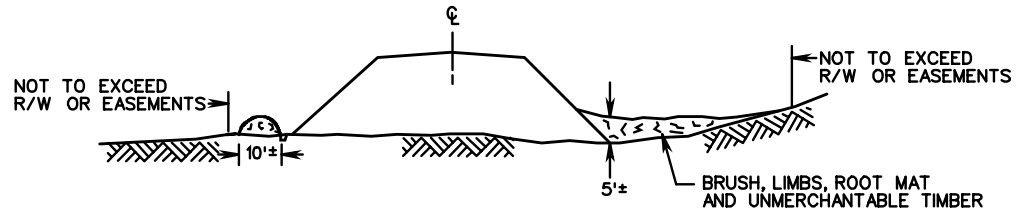

SECTION A-A

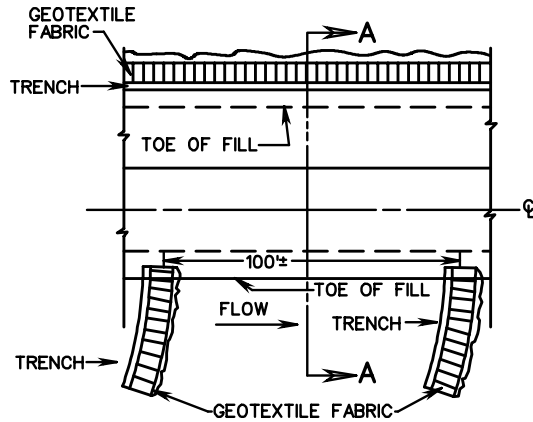
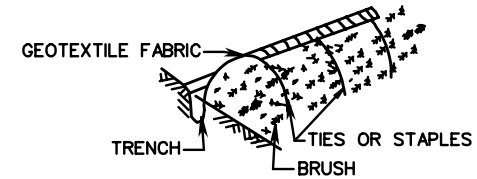

BACK ISOMETRIC

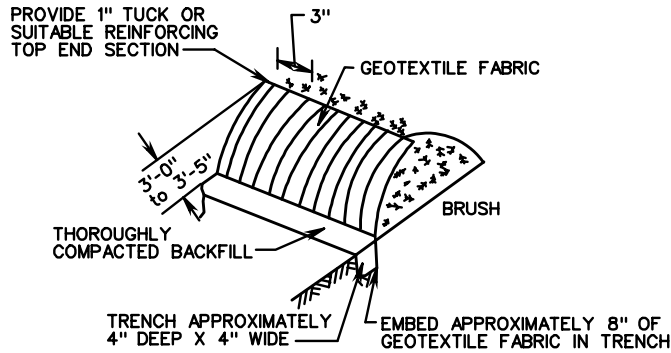

FRONT ISOMETRIC

NOTES:

1. BRUSH BARRIERS SHALL BE CONSTRUCTED AT LOCATION SHOWN ON THE PLANS OR AS DIRECTED BY THE ENGINEER. BRUSH SHALL BE PILED AGAINST EXISTING TREES TO PREVENT MOVEMENT OF BARRIER. BRUSH SHALL BE PILED AS TIGHTLY AS POSSIBLE AND WEIGHTED DOWN BY UNMERCHANTANTABLE LOGS.
2. GEOTEXTILE FABRIC CONFORMING TO THE ROAD AND BRIDGE SPECIFICATIONS SHALL BE INSTALLED AS DETAILED ABOVE. GEOTEXTILE FABRIC MAY ALSO BE ATTACHED TO EXISTING FENCES WHEN SPECIFIED ON THE PLANS OR DIRECTED BY THE ENGINEER.
3. NO BRUSH WILL BE DESTROYED OR REMOVED FROM THE PROJECT UNTIL ALL BRUSH SILT BARRIERS ARE IN PLACE AND HAVE BEEN INSPECTED AND APPROVED BY THE ENGINEER.
4. DIMENSIONS SHOWN ARE APPROXIMATE ONLY.

SPECIFICATION
REFERENCE

107
303

TEMPORARY EROSION & SILTATION CONTROL

VIRGINIA DEPARTMENT OF TRANSPORTATION