

- * 12" PIPE - 3 BARS - 10.68 LBS. REINFORCING STEEL
- 15" PIPE - 2 BARS - 7.79 LBS. REINFORCING STEEL
- 18" PIPE - 2 BARS - 7.79 LBS. REINFORCING STEEL

SCHEDULE OF REINFORCING STEEL						
MARK	NO.	LENGTH		SIZE	SPACING C-C	SHAPE
		2:1	1 1/2:1			
F	5	1'-0"	1'-0"	4	4"	STRAIGHT
G	*	4'-4"	4'-4"	4	4"	BENT
L	12	2'-0"		3	12"	BENT
L	10		2'-0"	3	12"	BENT

‡ QUANTITIES BASED ON 18" PIPE.

APPROXIMATE QUANTITIES			
PIPE SPILLOUT	SLOPE	CLASS A3 CONCRETE	REINFORCING STEEL
		CUBIC YARDS	LBS.
	2:1	‡ 0.482	*
	1 1/2:1	‡ 0.440	*

NOTE: DOWELS TO BE LOCATED AT ALL REQUIRED JOINTS.

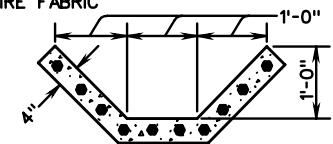
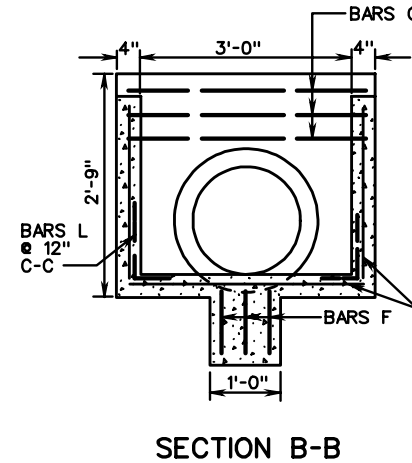
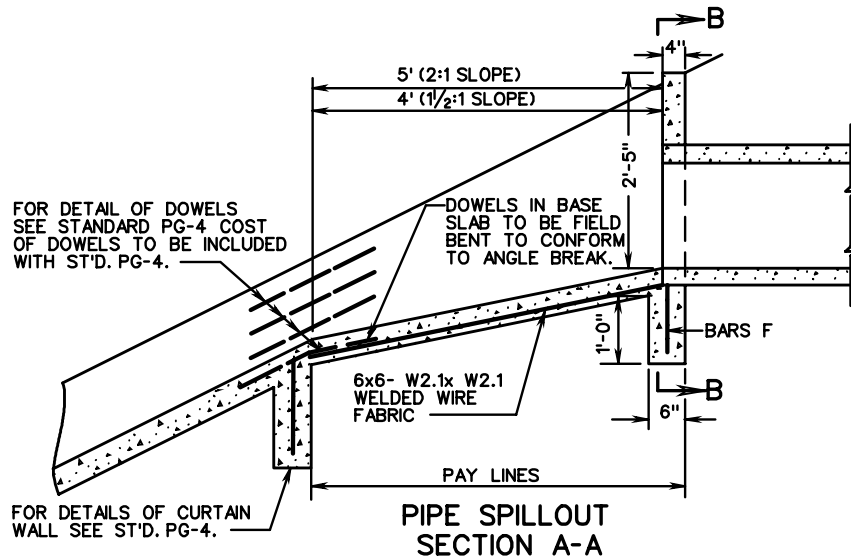

SPECIFICATION REFERENCE

302

STANDARD PIPE SPILLOUT FOR 12" - 18" PIPE CULVERTS

VIRGINIA DEPARTMENT OF TRANSPORTATION