

DETAIL "A"

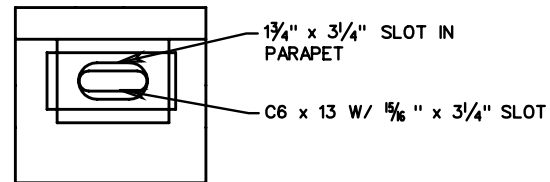

ALTERNATE SLOT DETAIL

NOTES:

1. BARRIER DELINEATOR TO BE SPACED IN ACCORDANCE WITH SECTION 702, OF THE ROAD AND BRIDGE SPECIFICATIONS AND THE BARRIER VERTICAL PANELS TO BE SPACED IN ACCORDANCE WITH VIRGINIA WORK AREA PROTECTION MANUAL. REFLECTIVE SURFACE, IN ALL INSTANCES, TO BE FACING ONCOMING TRAFFIC.
2. CONCRETE 4000 PSI (MIN.). REINFORCING STEEL GRADE 60.
3. AFTER REMOVING TEMPORARY BARRIER, CUT 7/8" Ø BOLT OR THREADED ROD AS LOW AS PRACTICAL BELOW ROADWAY SURFACE AND FILL RECESS WITH EPOXY BONDING COMPOUND EP-4 (DETAIL "A") OR REMOVE 7/8" Ø BOLTS OR THREADED RODS AND FILL HOLES WITH GROUT BONDED WITH EPOXY BONDING COMPOUND EP-4 (DETAIL "B").
4. ANCHOR SYSTEM SHOWN IN DETAIL "A" SHALL BE TESTED TO PROVIDE A MINIMUM PULLOUT OF 32,000 LBS. AND INSTALLED ACCORDING TO MANUFACTURER'S RECOMMENDATIONS.
5. COST OF BARRIER DELINEATOR AND BARRIER VERTICAL PANELS TO BE INCLUDED IN PRICE BID PER LINEAR FOOT OF BARRIER SERVICE.
6. WHEN BARRIER IS LOCATED ON VERTICAL AND/OR HORIZONTAL CURVES, THE OPENING AT THE JOINT IS NOT TO EXCEED 1".
7. DESIGN FEATURES RELATING TO CONSTRUCTION OR TO REGULATION AND CONTROL OF TRAFFIC MAY BE SUBJECT TO CHANGE AS DEEMED NECESSARY BY THE DEPARTMENT.
8. FOR POSITIVE CONNECTION DETAILS AND DIMENSIONS SEE SHEETS 501.59 - 501.61.

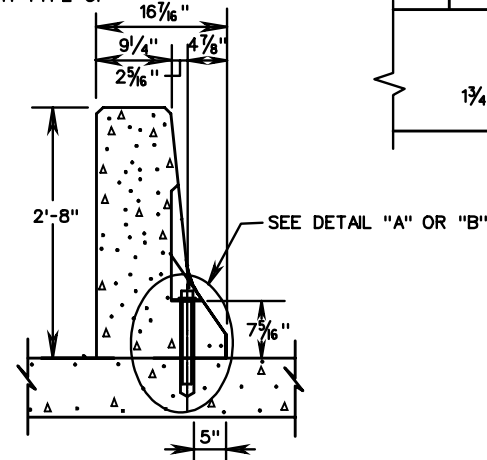

SECTION B-B (ANCHOR BOLT)

BOLT DOWN SIDE ADJACENT TO TRAFFIC.

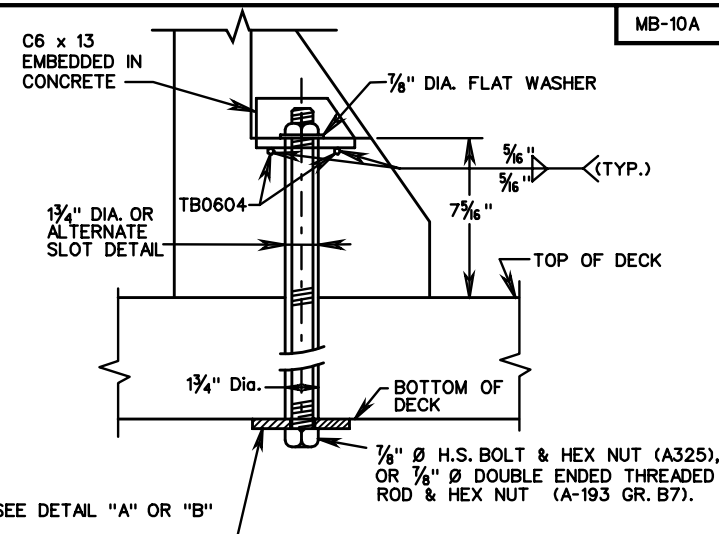

DETAIL "B"

3/2" x 3/2" x 1/2" SQUARE WASHER (A36 OR A572) WITH 5/16" Ø HOLE. AT THE DISCRETION OF THE ENGINEER, A LARGER WASHER SIZE MAY BE REQUIRED IF SPALLING IS EVIDENT AT BOTTOM OF DECK.

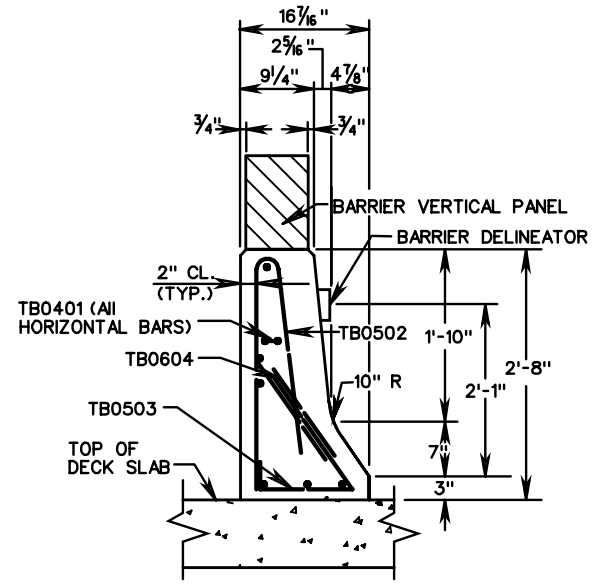

SECTION A-A

SPECIFICATION REFERENCE

TRAFFIC BARRIER SERVICE CONCRETE PARAPET (SINGLE FACE) (FOR TEMPORARY INSTALLATION ON BRIDGE DECK EXTERIOR)

VIRGINIA DEPARTMENT OF TRANSPORTATION