

PLAN
(SLOT REMOVED)

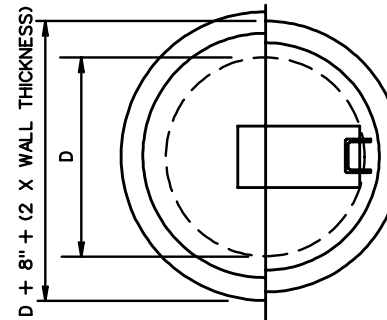

PLAN
(SLOT REMOVED)

| X DIM. | DEPTH |
|--------|------------|
| 8" | 0' TO 10' |
| 12" | 10' TO 16' |
| 16" | 16' TO 25' |

| Y DIM. | DEPTH |
|--------|------------|
| 5" | 0' TO 12' |
| 10" | 12' TO 25' |

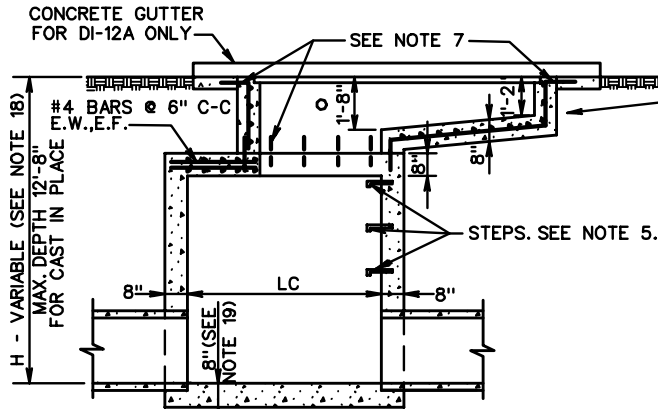

SECTION
(CAST IN PLACE)

MAXIMUM DEPTH: UNLIMITED, 60" MINIMUM DIAMETER.

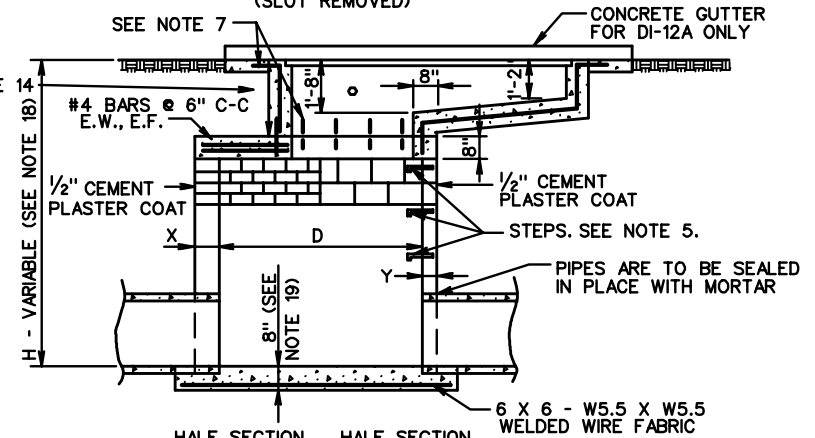

BRICK CONCRETE BLOCK

NOTES

- USE OF INLET RESTRICTED TO NON-VEHICULAR LOCATIONS.
- DEPTH OF INLET (H) AND LENGTH (L) TO BE SHOWN ON PLANS.
- THE "H" DIMENSION SHOWN ON THE STANDARDS AND SPECIFIED ON THE PLANS WILL BE MEASURED FROM THE INVERT OF THE OUTFALL PIPE TO THE TOP OF THE STRUCTURE.
- WHEN SPECIFIED ON THE PLANS THE INVERT IS TO BE SHAPED IN ACCORDANCE WITH STANDARD IS-1. THE COST OF FURNISHING AND PLACING ALL MATERIALS INCIDENTAL TO THE SHAPING IS TO BE INCLUDED IN THE BID PRICE FOR THE STRUCTURE.
- IN THE EVENT THE INVERT OF THE OUTFALL PIPE IS HIGHER THAN THE BOTTOM OF THE STRUCTURE, THE INVERT OF THE STRUCTURE SHALL BE SHAPED WITH CEMENT MORTAR TO PREVENT STANDING OR PONDING OF WATER IN THE STRUCTURE. THE COST OF FURNISHING AND PLACING ALL MATERIALS INCIDENTAL TO THE SHAPING IS TO BE INCLUDED IN THE BID PRICE FOR THE STRUCTURE.
- STEPS ARE TO BE PROVIDED WHEN H IS 4'-0" OR GREATER. FOR DETAILS SEE STANDARD ST-1.
- CHAMBER MAY BE PRECAST. SEE STANDARD 103.10 FOR DETAILS.
- # 4 DOWELS 12" LONG SPACED AT 12" C-C ALL SIDES.
- FOOTING MAY BE ROUND OR SQUARE IN SHAPE. KEY IS TO BE 1" DEEP X WALL THICKNESS + 1".
- ALL REINFORCING STEEL SHALL HAVE A MIN. COVER OF 2".
- ALL REINFORCING STEEL TO BE CUT CLEAR OF ALL OPENINGS BY 2".
- CAST-IN PLACE CONCRETE IS TO BE CLASS A3 (3000 PSI). PRECAST CONCRETE IS TO BE 4000 PSI.
- ALL REINFORCING BARS TO BE #4.
- GRATE BARS TO BE INSTALLED SO THEY WILL BE ALIGNED PARALLEL TO DITCH FLOW.
- FOR DETAILS OF CONCRETE SLOT, COLLAR AND GRATE, AND METHOD OF PLACING APPROACH GUTTER SEE SHEET 2 OF 3.
- PAVED DITCHES ARE TO BE TRANSITIONED TO MEET INLET GUTTER AS SHOWN IN ST'D. PG-2A.
- QUANTITIES SHOWN ARE FOR INLETS WITHOUT PIPES. PIPE DISPLACEMENTS MUST BE DEDUCTED TO OBTAIN TRUE QUANTITIES. SEE SHEET 3 OF 3 FOR QUANTITIES.
- PROVIDE SAFETY SLABS WHEN SPECIFIED ON THE PLANS.
- SEE TABULATION CHART ON SHEET 3 OF 3 FOR MINIMUM DEPTH (H).
- 10" THICK SLAB FOR PIPE SIZES 60" TO 72" IN DIAMETER.
- THE TYPE OF INLET DETAILED HEREON TO BE CONSTRUCTED WILL BE AT THE OPTION OF THE CONTRACTOR.
- DI-12 NO GUTTER.
DI-12A PERIPHERAL GUTTER.

SPECIFICATION REFERENCE

233
302

**MULTIGRATE DROP INLET
FOR PIPE SIZES 12" TO 72"**

VIRGINIA DEPARTMENT OF TRANSPORTATION