

# APPENDIX F

## Stormwater Program ESC, SWM, VSMP Construction Permit Requirements Flowchart

### Instructional and Informational Memoranda

<b>IIM-LD-11.24</b>	<b>Erosion And Sediment Control-Temporary Erosion And Sediment Control Measures To Be Incorporated Into Plans</b>
<b>IIM-LD-73.4</b>	<b>Riprap - Stone Dimensions Soil Survey Construction Procedure</b>
<b>IIM-LD-110.17</b>	<b>General Notes</b>
<b>IIM-LD-122.11</b>	<b>Roadside Development - Roadside Development Sheet; Coordination; Computing Quantities/Summarization</b>
<b>IIM-LD-166.4</b>	<b>Soil Stabilization Mat - Standard EC-3</b>
<b>IIM-LD-195.5</b>	<b>Management Of Stormwater - Engineering And Plan Preparation</b>
<b>IIM-LD-214.2</b>	<b>Culvert Design</b>
<b>IIM-LD-228</b>	<b>Sinkholes - Guidelines For The Discharge Of Stormwater At Sinkholes</b>
<b>IIM-LD-242</b>	<b>General Virginia Stormwater Management Program (VSMP) Construction Permit</b>
<b>HDA 05-03</b>	<b>VDOT's Adoption &amp; Implementation of NOAA ATLAS 14 Rainfall Precipitation Frequency Data</b>
<b>HDA 05-04.1</b>	<b>Application of NRCS "TR-55" and "TR-20" Hydrologic Computations Using NOAA ATLAS 14 Rainfall Data</b>
<b>HDA 06-03</b>	<b>Culvert Outlet Protection</b>
<b>HDA 07-01</b>	<b>Stormwater Management Plans</b>

# VDOT STORMWATER PROGRAM - ESC, SWM, VSMP CONSTRUCTION PERMIT REQUIREMENTS

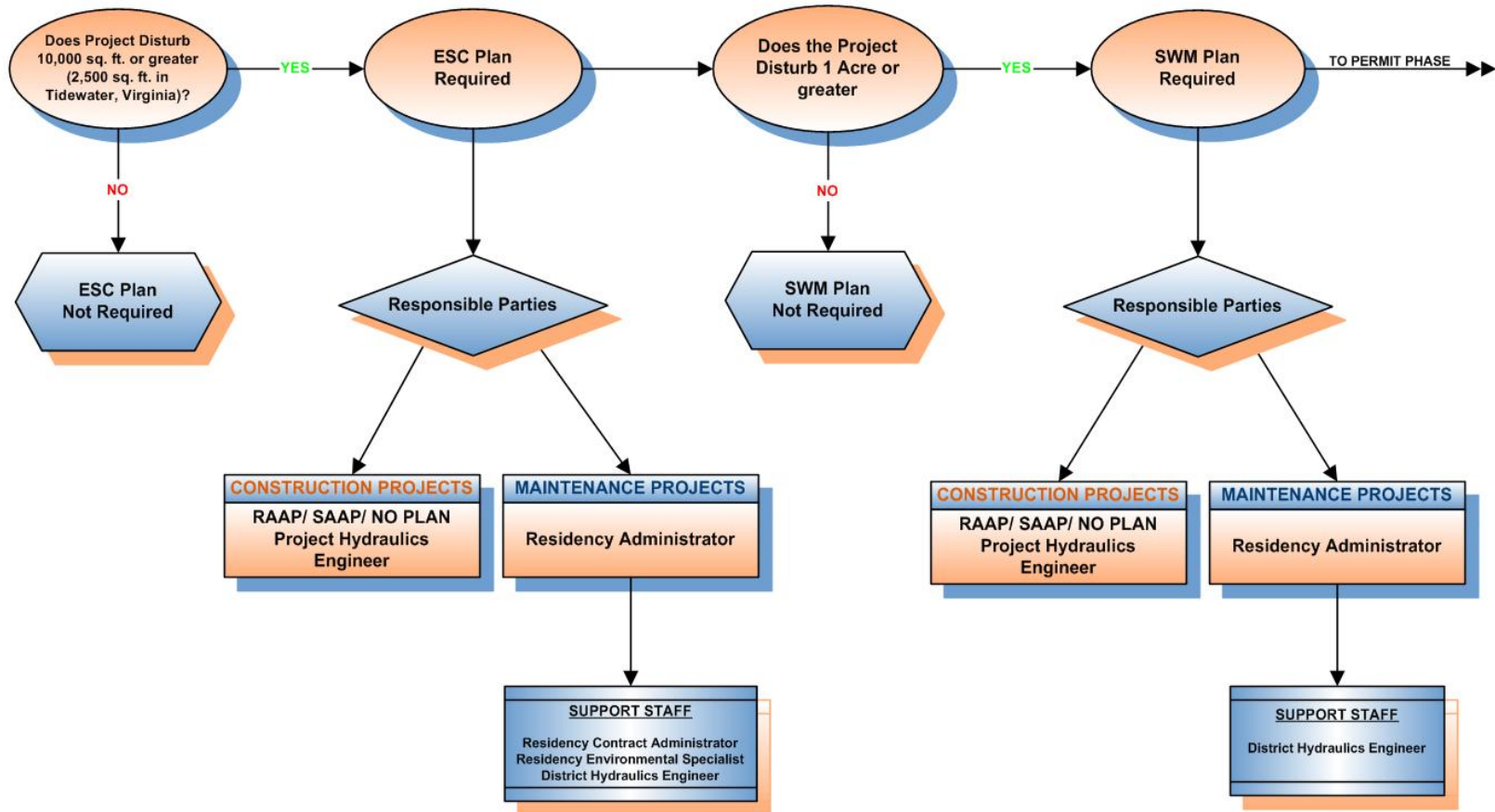

**PLAN DESIGN PHASE - For Construction and Maintenance Activities**

# VDOT STORMWATER PROGRAM - ESC, SWM, VSMP CONSTRUCTION PERMIT REQUIREMENTS

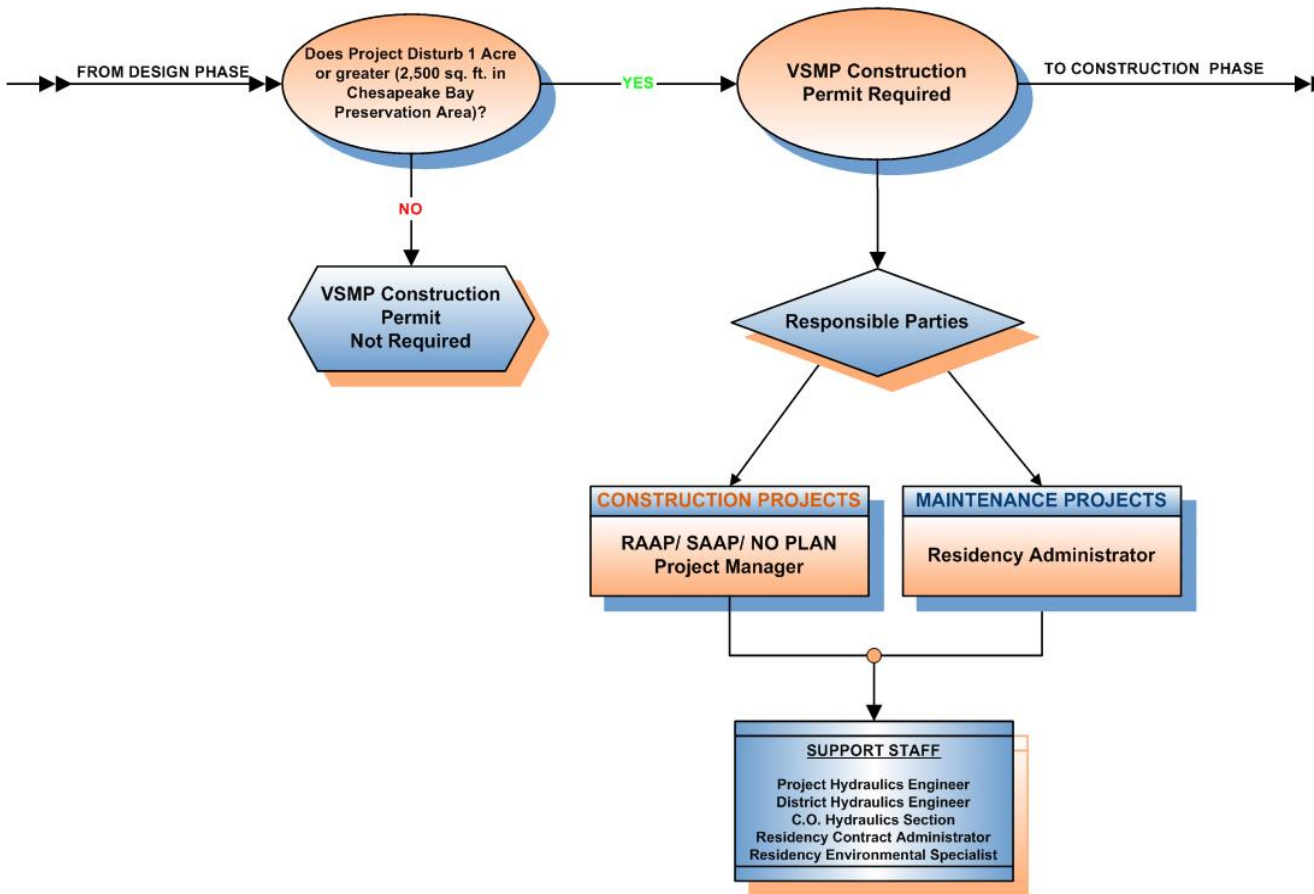

## VSMP CONSTRUCTION PERMIT PHASE - For Construction and Maintenance Activities

# VDOT STORMWATER PROGRAM - ESC, SWM, VSMP CONSTRUCTION PERMIT REQUIREMENTS

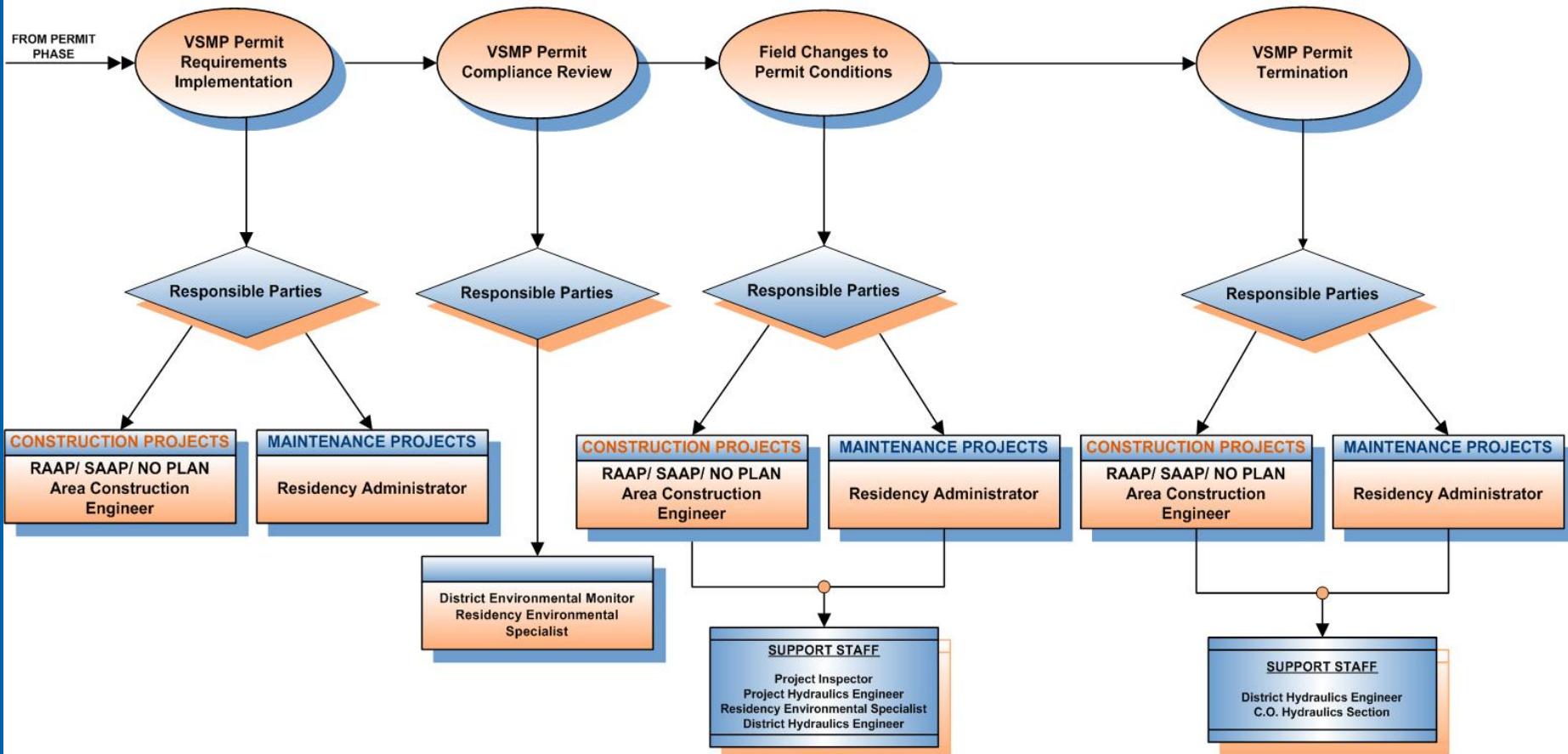

## CONSTRUCTION PHASE - For Construction and Maintenance RLD Activities

VIRGINIA DEPARTMENT OF TRANSPORTATION

# LOCATION AND DESIGN DIVISION

## INSTRUCTIONAL AND INFORMATIONAL MEMORANDUM

GENERAL SUBJECT: EROSION AND SEDIMENT CONTROL PROGRAM	NUMBER: IIM-LD-11.24
SPECIFIC SUBJECT: PROGRAM ADMINISTRATION AND MINIMUM REQUIREMENTS FOR THE DEVELOPMENT AND IMPLEMENTATION OF EROSION AND SEDIMENT CONTROL PLANS	DATE: AUGUST 15, 2006
	SUPERSEDES: IIM-LD-11.23
DIVISION ADMINISTRATOR APPROVAL:	Mohammad Mirshahi, P.E. State Location and Design Engineer Approved August 15, 2006

**Shading** has been omitted from this memorandum.

---

### CURRENT REVISION

---

- Instructions on the design criteria and procedures of erosion and sediment control features will be contained in the *VDOT Drainage Manual*, Appendix 10B.
- Program administration details and instructions on the development of erosion and sediment control plans for Standard, Minimum, No Plan, SAAP, Capital Outlay and State Force Construction/Maintenance Projects are contained in this IIM.
- Instructions on the development and implementation of erosion and sediment control plans have been revised to comply with the Virginia Department of Conservation and Recreation's approval of VDOT's Erosion and Sediment Control and Stormwater Management Standards and Specifications and the Virginia Stormwater Management Program Permit requirements.

---

### EFFECTIVE DATE

---

- This memorandum is effective upon receipt for all projects that have not progressed beyond the Pre-Advertisement Conference (or similar) Stage (where right of way will not be affected by these instructions) or Right of Way Stage (where additional right of way or easements may be required to implement these instructions).

## ACRONYMS

- The following acronyms are used within this document:
  - ACE – Area Construction Engineer
  - CA – Contract Administrator
  - CEP – Concurrent Engineering Process
  - DCR – Department of Conservation and Recreation
  - EPA – Environmental Protection Agency
  - ESC – Erosion and Sediment Control
  - ESCCC – Erosion and Sediment Control Contractor Certification
  - FI – Field Inspection
  - HDA – Hydraulic Design Advisory
  - IIM – Informational and Instructional Memorandum
  - PFI – Preliminary Field Inspection
  - PM – Project Manager
  - RA – Residency Administrator
  - R&B – Road and Bridge
  - RLD – Responsible Land Disturber
  - RLDA – Regulated Land Disturbance Activity
  - SLS – Straight Line Sketch
  - SWM – Stormwater Management
  - TMDL – Total Maximum Daily Load
  - VDOT – Virginia Department of Transportation
  - VSMP – Virginia Stormwater Management Program
  - VTCA – Virginia Transportation Construction Alliance

---

## 1.0 PROGRAM ADMINISTRATION

---

- 1.1 VDOT receives an annual approval of its ESC Standards and Specifications from DCR. By its annual approval of VDOT's ESC Standards and Specifications, DCR authorizes VDOT to administer its ESC Program in accordance with the Approved ESC Standards and Specifications, on all land disturbance activities undertaken by the Department.
- 1.2 VDOT's Approved ESC Standards and Specifications shall apply to all plan design, construction and maintenance activities undertaken by VDOT, either by its internal workforce or contracted to external entities, where such activities are regulated by the Virginia ESC Law and Regulations. During any inspections of VDOT land disturbing activities by DCR, EPA and other such environmental agencies, compliance with the VDOT's Approved ESC Standards and Specifications (and all parts thereof) will be expected.
- 1.3 Any revisions to VDOT's Approved ESC Standards and Specifications shall be reviewed and approved by DCR prior to implementation by VDOT. Such review and approval shall be coordinated by the VDOT ESC Program Administrator.

- 1.4 Where determined necessary to meet an individual project need, VDOT may request DCR to grant a project specific variance to the Approved ESC Standards and Specifications.
  - 1.4.1 All requests for project specific variances to VDOT's Approved ESC Standards and Specifications shall be sent by the ESC Plan Designer/Hydraulics Engineer to the VDOT ESC Program Administrator and shall be accompanied by complete details and documentation, including justification for the requested variance and concurrence by the local DCR ESC Program representative.
  - 1.4.2 The VDOT ESC Program Administrator shall coordinate the review and approval of all requested variances with DCR's ESC Program Administrator.
  - 1.4.3 All requested variances are to be considered unapproved until written approval from DCR is received.
  - 1.4.4 All approved variances shall be listed in the ESC General Notes section of the ESC plans for the land disturbing activity (see IIM-LD-110 and Section 5.2.10 of this IIM).
  - 1.4.5 All documentation for and approval of requested variances shall be retained in the appropriate (i.e. design, construction, etc.) files of the proposed activity.
- 1.5 Non linear projects, such as those administered by the VDOT's Capital Outlay Program, may utilize VDOT's Approved ESC Standards and Specifications or DCR's ESC Standards and Specifications as outlined in the Virginia Erosion and Sediment Control Regulations and Handbook or a combination of the two. Such projects include, but are not limited to, new and/or additions/modifications to Rest Areas, District or Residency Office complexes, Area Maintenance Headquarters/Repair Shops and buildings on the right of way or associated with bridges/piers/tunnels, spreader/tailgate/wash rack sites, holding ponds or containment pads, fuel dispensing facilities, security facilities and drainage improvements to building/parking sites/structures.

---

## 2.0 DCR CERTIFICATIONS

---

- 2.1 The Virginia ESC Law and Regulations require that the ESC Program administration and the ESC Plan design, impletion and inspection activities be conducted by DCR certified personnel for all Regulated Land Disturbance Activities.
- 2.2 VDOT's ESC Program will be administrated by a DCR Certified Program Administrator.

- 2.2.1 The Program Administrator shall be the person within the Department who has been designated to have overall responsibility for administration of VDOT's ESC Program.
  - 2.2.2 The DCR Program Administrator Certification is acquired by satisfying the DCR eligibility/training requirements and passing the DCR Program Administrator Exam or by possessing a DCR Combined Administrator Certification.
  - 2.2.3 The State Hydraulics Engineer in the Central Office Location and Design Division is currently designated as VDOT's ESC Program Administrator.
- 2.3 The Virginia ESC Regulations require that each RLDA be overseen by a DCR certified RLD.
- 2.3.1 The DCR RLD Certification is required for the VDOT person who has general oversight of the construction phase of a specific RLDA.
  - 2.3.2 The RLD for a specific RLDA must be identified prior to beginning any land disturbance activity (See Section 5.2.3 of this IIM).
  - 2.3.3 The DCR RLD Certification is acquired by passing the DCR RLD Exam or by possessing a DCR Combined Administrator, Program Administrator, Plan Reviewer or Inspector Certification or by possessing a Professional Engineer, Land Surveyor, Landscape Architect or Architect License pursuant to Chapter 4, Title 54.1, of the Code of Virginia.
- 2.4 The proposed ESC Plan for each RLDA must be reviewed and approved by a DCR Certified ESC Plan Reviewer to ensure that the ESC Plan has been developed in accordance with VDOT's Approved ESC Standards and Specifications or variances authorized thereto.
- 2.4.1 The DCR Plan Reviewer Certification is required for any person that has responsibility for reviewing and approving the proposed erosion and sediment control plan for a specific RLDA.
  - 2.4.2 The Certified Plan Reviewer shall be a VDOT employee, or an employee of an engineering consulting firm working for VDOT, who has expertise in drainage design and erosion and sediment control design.
  - 2.4.3 The DCR Plan Reviewer Certification is acquired by satisfying the DCR eligibility/training requirements and passing the DCR Plan Reviewer Exam or by possessing a DCR Combined Administrator Certification or by possessing a Professional Engineer, Land Surveyor, Landscape Architect or Architect License pursuant to Chapter 4, Title 54.1, of the Code of Virginia.



- 2.5 A DCR ESC Inspector Certification is required for those persons having responsibility for ensuring the proper implementation of, or compliance with, the proposed ESC Plan and VDOT's Approved ESC Standards and Specifications, or variances authorized thereto, throughout the construction phase of the RLDA, including all inspection requirements.
- 2.5.1 The Certified Inspector shall be a VDOT employee or an employee of an engineering consulting firm working for VDOT.
- 2.5.2 The DCR Inspector Certification is acquired by satisfying the DCR eligibility/training requirements and passing the DCR Inspector Certification Exam or by possessing a DCR Combined Administrator Certification.
- 2.6 It shall be the responsibility of the Project Authority to ensure that those staff with the appropriate DCR Certifications (RLD, Plan Reviewer or Inspector) performs the functions required by the ESC Law and Regulations and noted in Sections 2.3 through 2.5.
- 2.6.1 For the purposes of this document, the Project Authority is defined as that person with overall responsibility of a land disturbing activity or a specific phase of a land disturbing activity.
- 2.6.2 The Project Authority for preconstruction (design) activities is typically the PM, Residency CA, RA or other such person responsible for this phase of the land disturbing activity. This person shall ensure that the proposed ESC Plan has been reviewed and approved by a DCR Certified Plan Reviewer.
- 2.6.3 The Project Authority for actual land disturbance (construction) activities is typically the ACE, RA or other such person responsible for this phase of the land disturbing activity. This person shall ensure that the RLDA has an assigned DCR Certified RLD and that the impletion of the ESC Plan, including inspection requirements, is being overseen by a DCR Certified Inspector.

---

### 3.0 VDOT TRAINING/CERTIFICATIONS

---

- 3.1 Where land disturbing activities occurring within VDOT right of way are regulated under the Virginia ESC Law and Regulations, Section 107.14(a) of the VDOT R&B Specifications requires that all contractors performing such land disturbing activities have a person certified by the Department in erosion and sediment control within the project limits. This certification requirement is mandatory for both those contractors performing land disturbing activities under contracts managed by VDOT (including PPTA and Design Build agreements) and for those performing land disturbing activities on VDOT right of way under a Land Use Permit.

EXCEPTION – Those contractors performing maintenance related land disturbing activities under a hired equipment contract whose work is directly supervised by VDOT personnel.

- 3.1.1 Successful completion of the Department’s “Erosion and Sediment Control Contractor Certification” course satisfies the certification requirements of Section 107.14 (a) of the VDOT R&B Specifications.
- 3.1.2 The ESCCC is a joint training effort between VDOT and VTCA. The VDOT Stormwater Technical Committee develops the course material and VTCA administers the training, testing and issuance of certifications.
- 3.2 The VDOT “In Stream Maintenance Training” course is required training for all VDOT personnel performing or supervising maintenance activities, where such activities are regulated under the Virginia ESC Law and Regulations.
  - 3.2.1 The “In Stream Maintenance Training” course is developed and administered by VDOT’s Central Office Environmental Division.
  - 3.2.2 The “In Stream Maintenance Training” course consists of several modules that are targeted toward best management practices for working in and around streams and other environmentally sensitive areas and controlling erosion and sedimentation associated with land disturbance on maintenance activities.
  - 3.2.3 The “In Stream Maintenance Training” course is designed to be conducted at the local level (i.e., Residency, Area Maintenance Headquarters, etc.) by the Residency Environmental Specialist and the modules can be taught individually in short group meetings or they can be combined into one or more groups and taught at a more formal session. Future initiatives will make a web based training option available for use, as appropriate.

---

#### 4.0 POLICY/GENERAL GUIDELINES

---

- 4.1 Requirements of the Virginia ESC Regulations and the VDOT ESC Standards and Specifications, as approved by the DCR and described herein, shall be incorporated into all erosion and sediment control designs and shall be enforced on all Regulated Land Disturbance Activities managed by VDOT.
- 4.2 When requested by DCR, and where deemed practical, VDOT projects located in jurisdictions with more stringent ESC technical criteria than that required by State regulations, shall be designed to meet those more stringent criteria. The local criteria may be part of a locally adopted State approved program or may be part of a watershed initiative related to the protection of a water supply, a TMDL implementation plan, or a Tributary Strategy Plan. If appropriate, it will be the

responsibility of the ESC Plan Designer to demonstrate that the local requirements are not practical for the project under consideration. Early coordination should occur between the ESC Plan Designer and the District Environmental Manager and the local program authority in order to identify any such requirements.

- 4.3 Any maintenance or construction activity disturbing 2,500 square feet (232 m<sup>2</sup>) or greater within the area of Tidewater, Virginia, as defined in the Virginia Chesapeake Bay Preservation Act, must have a project specific ESC Plan developed and implemented in accordance with the VDOT's Approved ESC Standards and Specifications. Tidewater, Virginia is defined as the Counties of Accomack, Arlington, Caroline, Charles City, Chesterfield, Essex, Fairfax, Gloucester, Hanover, Henrico, Isle of Wight, James City, King George, King and Queen, King William, Lancaster, Matthews, Middlesex, New Kent, Northampton, Northumberland, Prince George, Prince William, Richmond, Spotsylvania, Stafford, Surry, Westmoreland and York and the Cities of Alexandria, Chesapeake, Colonial Heights, Fairfax, Falls Church, Fredericksburg, Hampton, Hopewell, Newport News, Norfolk, Petersburg, Poquoson, Portsmouth, Richmond, Suffolk, Virginia Beach and Williamsburg.
- 4.4 Any maintenance or construction activity disturbing 10,000 square feet (929 m<sup>2</sup>) or greater in areas other than those within Tidewater, Virginia (as defined above) must have a project specific ESC Plan developed and implemented in accordance with VDOT's Approved ESC Standards and Specifications.
- 4.5 VDOT shall be responsible for ensuring compliance with its approved ESC Standards and Specifications by private entities (i.e., agents, contractors, subcontractors, consultants) conducting regulated land disturbance activities on projects managed by VDOT, including those constructed under the Public/Private Transportation Act (PPTA), the Design/Build process and the Capital Outlay Program.
- 4.6 When not included in the proposed ESC Plan for the RLDA, the contractor must provide an ESC Plan in accordance with Section 106 of the VDOT R&B Specifications for borrow pit sites and disposal area sites specifically utilized to obtain or dispose of project materials. Any such ESC Plan provided by the contractor must comply with VDOT's Approved ESC Standards and Specifications. Where required, the contractor must design, construct and maintain sediment basins at these sites. The contractor shall supply supporting calculations for sediment basin design and calculations demonstrating compliance with the Virginia ESC Regulation MS-19 for an adequate receiving channel. All information provided by the contractor should be reviewed by the District Hydraulics Engineer or other appropriate VDOT personnel to ensure accuracy, the use of appropriate methodology and compliance with VDOT's Approved ESC Standards and Specifications, Virginia ESC Law and Regulations, and VSMP Construction Permit Conditions.

## 5.0 MINIMUM REQUIREMENTS FOR ALL EROSION AND SEDIMENT CONTROL PLANS

---

5.1 The ESC Plan shall depict (using appropriate plan symbols) locations where specific measures are needed in order to control erosion and sediment deposition within the RLDA limits. Specific erosion and sediment control measures include, but are not limited to, protective linings for ditches, pipe outlet protection, filter barrier, silt fence, check dams, silt traps, sediment traps, sediment basins, diversion berms and ditches, etc. The ESC Plan should be based on the existing field conditions at the time of design, the anticipated sequence of construction, and the site conditions expected as the RLDA is brought to final grade.

### 5.2 Erosion Control Plan Information

To comply with the requirements of the VSMP Construction Permit, the following information is to be included in the Erosion and Sediment Control Section of the Plan General Notes (see IIM-LD 110 for additional information). Information to complete the ESC General Notes will be developed by the ESC Plan Designer with assistance from District Hydraulics or Residency staff as needed.

#### 5.2.1 Project Description

Examples:

- This roadway construction project consists of adding two additional parallel lanes to an existing two lane rural roadway facility.
- This roadway construction project consists of improving an existing urban roadway intersection by adding left turn and right turn lanes.
- This roadway construction project consists of replacement of an existing bridge with a new bridge and improvements to the existing roadway approaches.
- This roadway construction project consists of widening an existing urban street and adding additional turn lanes.
- This roadway maintenance project consists of regrading and enlarging the roadside ditches and replacing drainage pipes along an existing rural roadway.

5.2.2 The location (city or county) of the project, the total area, in acres, of the site that is expected to be disturbed by the proposed activities and the applicability of the DCR VSMP Construction Permit.

Example:

- This project is located in Hanover County and approximately 10.5 acres will be disturbed by the proposed construction/maintenance activity. This project is covered under the DCR01 VSMP General Permit For Discharges Of Stormwater From Construction Activities.

5.2.3 The person designated as the Responsible Land Disturber for the RLDA (Name and Title).

Example:

- The Area Construction Engineer, Joe Smith, is designated as the Responsible Land Disturber for this Regulated Land Disturbance Activity.

5.2.4 Description of any surface waters, wetland features or other environmentally sensitive/critical areas immediately adjacent to the RLDA which are not otherwise identified on the plans.

Example:

- There is one farm pond located 1500' north of Station 29+00 Route 602 and an existing perennial stream located 1000' east of and parallel to Route 55 between Stations 204+00 and 212+00.

5.2.5 Description of existing and proposed drainage patterns and approximate slopes or contours (a drainage area map in the project file showing contours/drainage patterns can be referenced to provide the pre and post-drainage areas used for design).

Example:

- A contour map depicting existing/proposed contours/drainage patterns is contained in the project drainage file located in the VDOT Salem District Office Hydraulics Section.

5.2.6 Description of any off-site borrow areas or surplus material disposal areas to be covered by the ESC Plan (reference can be made to Sections 106.03 and 106.04 of the R&B Specifications).

Examples:

- There are no anticipated off-site borrow areas or surplus material disposal areas associated with this project.
- Embankment material needed to complete the construction of this project will be obtained from an off-site borrow area(s) identified by the Department and/or the contractor and approved by the Department. The erosion and sediment control plan for such areas is to be developed in accordance with the Department's Approved Erosion and Sediment Control and Stormwater Management Standards and Specifications and Section 106.03 of the Road and Bridge Specifications.
- Unsuitable or surplus material derived from the construction of this project will be disposed of off-site at area(s) identified by the contractor and approved by the Department. The erosion and sediment control plan for such areas is to be developed in accordance with the Department's Approved Erosion and Sediment Control and Stormwater Management Standards and Specifications and Section 106.04 of the Road and Bridge Specifications.

5.2.7 Description of any other potential pollution sources, such as vehicle fueling, storage of fertilizers or chemicals and sanitary waste facilities (reference can be made to Contract Special Provision S107F).

Example:

- The contractor shall identify locations of potential pollution sources such as vehicle fueling areas, storage areas for fertilizers and chemicals, sanitary waste facilities, etc. and shall develop a stormwater pollution prevention plan for such sites in accordance with Contract Special Provision S107F.

5.2.8 Name of the nearest receiving waters.

Example:

- Stormwater run-off from the construction areas of this project will flow into the following streams: Broad Branch, Deep Creek and Dry Run.

5.2.9 A description of maintenance and inspection requirements of temporary erosion and sediment control measures (reference can be made to Sections 107.14 and 303.03 of the R&B Specifications and Contract Special Provision S107F).

Example:

- Inspection and maintenance of temporary erosion and sediment control measures will be completed in accordance with Sections 107.14 and 303.03 of the Department's Road and Bridge Specifications and Contract Special Provision S107F.

5.2.10 A list of any project specific variances to the Approved ESC Standards and Specifications that have been authorized, in writing, by DCR. List should include a brief description of the variance, dated approved and by whom.

Example

- The following variances to the Department's Approved Erosion and Sediment Control Standards and Specifications have been approved by the Department of Conservation and Recreation:

1. A variance to decrease the height of silt fence to 26" approved by letter from Mr. Eric Capps dated July 15, 2006.

### 5.3 Sequence of Construction

The proposed ESC Plan shall be developed in conjunction with the proposed Sequence of Construction Plan and should denote the required erosion and sediment controls for the intended sequence of major construction activities. In planning the sequence of construction, consideration should be given to elimination or minimization of the need for major erosion and sediment control facilities, such as sediment basins, by strategic planning of the construction timing and location of erosion and sediment control measures, grading operations, temporary and permanent channels and drainage facilities. Any changes to the proposed sequence

of construction plan that could potentially cause a significant change to the proposed ESC or Drainage Plan shall be submitted to the ESC Plan Designer/Hydraulics Engineer for evaluation of impacts.

#### 5.4 Contents of ESC Plan

Details of the RLDA'S ESC Plan may be shown on, but is not limited to, the plan, profile, typical section and detail sheets of the construction plan set. The ESC Plan shall contain the following information:

5.4.1 ESC General Notes (see IIM-LD-110).

5.4.2 Limits of clearing and grading.

5.4.3 Location of temporary and permanent erosion and sediment control and related stormwater management features.

5.4.4 Construction details for any temporary or permanent erosion and sediment control or related stormwater management features if different from the VDOT R&B Standards and Specifications.

5.4.5 Location of any surface waters, wetland features, or other environmentally sensitive/critical areas within or immediately adjacent to the RLDA area. (Such features located within close proximity of the project, yet outside the limits of the plan, shall be described in the ESC General Note E-1.)

5.4.6 Location of other potential pollutant sources as described in ESC General Note E-1.

---

## 6.0 PLAN DEVELOPMENT PROCESS

---

6.1 The decision as to which type of ESC Plan concept (Single Phase or Multiple Phase Plan) to develop for each RLDA shall be determined by the ESC Plan Designer/Hydraulics Engineer and the Project Manager (or other such project authority) during the initial stages of plan development.

#### 6.2 Concurrent Engineering Plan Development Process

The CEP Development Process incorporates the principles of teamwork, flexibility, and milestones. The development, review, and approval of the project specific erosion and sediment control plan is included in the CEP milestones as follows:

##### 6.2.1 Scoping Stage

The ESC Plan Designer/Hydraulics Engineer shall identify any local ESC or related SWM technical criteria or watershed initiatives that may influence the ESC or related SWM design of the project. This should include early

coordination with the local program authority and the District Environmental Manager to assess any impacts on the project design.

#### 6.2.2 PFI/Public Hearing Stage

The ESC Plan Designer/Hydraulics Engineer shall develop preliminary ESC and associated SWM Plans and show locations of all major erosion and sediment control, stormwater management, and/or drainage structures on the plans that may affect the required right of way. The District Environmental Manager shall provide comments, as appropriate, to the ESC Plan Designer/Hydraulics Engineer regarding the preliminary plan, including any pertinent information that might affect the final design of the ESC Plan.

#### 6.2.3 FI Stage

Prior to the FI, the ESC Plan Designer/Hydraulics Engineer shall develop final ESC and associated SWM plans and show final design locations, sizes, and other plan details as necessary to accurately determine the required right-of-way and/or easement, and to determine whether the selected ESC Plan Concept is appropriate. The ESC and related SWM Plan design shall address any comments or recommendations from the Public Hearing process as accepted/incorporated by the Project Manager (or other such project authority). This phase of the ESC and related SWM Plan design process provides all the necessary information needed to conduct a thorough Field Inspection. The District Environmental Manager shall provide comments, as appropriate, to the ESC Plan Designer/Hydraulics Engineer regarding the proposed ESC Plan.

#### 6.2.4 ESC Plan Design Completion

After FI and prior to the Right of Way stage, the ESC Plan Designer/Hydraulics Engineer shall incorporate all changes, deletions, and/or additions into the ESC and related SWM Plan resulting from any FI and/or Quality Control Review comments or plan revisions. The ESC Plan shall be carefully reviewed for compliance with the approved VDOT ESC Standards and Specifications including the types of proposed measures, means of access for maintenance, and required right of way and/or easements.

#### 6.2.5 ESC & SWM Plan Design Certification

Prior to the Pre-Advertisement Conference (or similar project meeting), the ESC Plan Designer/Hydraulics Engineer shall have the ESC and related SWM Plan reviewed by a DCR Certified ESC Plan Reviewer. The ESC Plan Reviewer shall verify that the ESC and related SWM Plan for the project is in compliance with the VDOT Approved ESC and SWM Standards and Specifications. Any comments by the Plan Reviewer shall be addressed with the ESC Plan Designer/Hydraulics Engineer. Once all comments have been reconciled, the ESC Plan Reviewer completes, signs and forwards the ESC & SWM Plan Design Certification Form (LD-445C) to the ESC Plan Designer/Hydraulics Engineer. The ESC Plan Designer/Hydraulics Engineer provides the completed LD-445C to the Project Manager (or other such



project authority) for use in the VSMP Construction Permit Process (See IIM-LD-242), as applicable, and to the District Environmental Manager for use in the Environmental Quality Assurance process.

#### 6.2.6 Pre-Advertisement Conference

The District Environmental Manager shall complete the Quality Assurance Review for use in the Environmental Certification process.

### 6.3 Plan Development Process for Special Advertisement and Award Process (SAAP) and “No Plan” Projects

6.3.1 A “No Plan” project is defined as an assembly of letter size sketches and narratives depicting the project’s location, typical cross section, estimated quantities and any other specific details necessary (i.e., ESC and/or SWM plans) for the construction of the project. Any “No Plan” project that disturbs 2,500 square feet (232 m<sup>2</sup>) or greater in Tidewater, Virginia or 10,000 square feet (929 m<sup>2</sup>) or greater elsewhere within the State must have a project specific ESC Plan. A project developed under the “No Plan” concept is one that generally requires little or no survey, engineering or hydraulic analysis in order to produce the necessary contract documents. Any required right of way is generally acquired through donations in lieu of the purchase/condemnation process. See Appendix A of the *VDOT Road Design Manual* for additional information on the “No Plan” concept.

6.3.2 “SAAP” Projects are defined as those advertised under the Special Advertisement and Award Process. The “No Plan” concept is generally used to produce the required contract documents. “SAAP” projects generally have one or more of the following characteristics:

- They require little or no preliminary engineering.
- They are standard maintenance repair contracts (e.g., bridge, guardrail or concrete pavement repairs).
- They are standard incidental construction and/or improvement projects of limited scope.
- The work being performed involves a singular function or specialty work (e.g., bridge painting, pavement markings or pipe installation).

Any “SAAP” project that disturbs 2,500 square feet (232 m<sup>2</sup>) or greater in Tidewater, Virginia or 10,000 square feet (929 m<sup>2</sup>) or greater elsewhere within the State must have a project specific ESC Plan.

6.3.3 During the early stages of the preparation of the contract assembly for any “SAAP” or “No Plan” Project, the Contract Administrator (CA) (or other such project authority) should conduct a Scoping Meeting to determine what is needed on the project in order to comply with the VDOT Approved ESC and SWM Standards and Specifications. This should include filling out Forms LD-439 and EQ-429 to the extent possible.

The Scoping Meeting should include the CA, the District L&D Engineer and/or Hydraulics Engineer, and the appropriate District Environmental Section personnel in order to accurately determine the project requirements.

6.3.4 The CA, with the assistance of the District Hydraulics Engineer (as needed), or other appropriately qualified personnel, should prepare a preliminary Straight Line Sketch (SLS) in accordance with Form LD-438.

6.3.5 Upon completion of the Preliminary SLS, the CA should coordinate with the appropriate personnel in the District Hydraulics Section and the District Environmental Section to schedule a Field Review. The following data should be made available to all Field Review participants:

- A completed Form EQ-429 and Form LD-439.
- A Vicinity Map – United States Geological Survey (USGS) Topographical Map and County Road Map showing the location and limits of the proposed project.
- A SLS of the project prepared in accordance with Form LD-438, showing the project limits and the approximate location of proposed drainage items and erosion and sediment control items.

6.3.6 If during the Field Review it is found that such items as stormwater management facilities, drainage improvements, temporary sediment basins or temporary sediment traps are required, the District Hydraulics Section will determine and request the necessary survey data, and provide engineering support in the development of the SLS to ensure consistency with the VDOT Approved ESC and SWM Standards and Specifications.

6.3.7 Upon completion of the design of any required stormwater management facilities, drainage improvements, or sediment trapping facilities, the District Hydraulics Section and the District Environmental Section will provide the CA with final comments, recommendations and plan details.

6.3.8 Final approval of the SLS:

- Upon incorporation of all the required revisions, a DCR Certified ESC Plan Reviewer shall make a final review of the ESC and/or SWM Plan. Once any Plan Reviewer comments have been reconciled with the ESC Plan Designer/Hydraulics Engineer, the Plan Reviewer shall complete and sign the LD-445C Erosion and Sediment Control and Stormwater Management Certification form and forward it to the CA for use in the VSMP Construction Permit Process (See IIM-LD-242), if applicable.
- The CA will incorporate the final SLS, and Special Provisions S107F and S107G into the contract assembly.

- Thereafter, any significant change to the project that may impact the ESC, SWM, or Drainage Plan will require resubmission of the revised SLS to the ESC Plan Designer and/or District Hydraulics Engineer for review and approval prior to implementation.

6.3.9 The final version of the SLS and any associated ESC General Notes or Construction Notes will serve as the ESC and SWM Plan for the project. During the construction phase of the project, a copy of the ESC and SWM Plan shall be kept on the project site (Record Set) and in the project file at the Residency Office as documentation that all policies and procedures have been addressed with regard to the SWM and ESC requirements of the project. During construction, any changes to the proposed ESC Plan necessitated by unforeseen conditions or other circumstances shall be documented on the Record Set of the ESC Plan.

#### 6.4 Plan Development Process for State Force Construction Projects

- 6.4.1 State Force Construction Projects include land-disturbing activities that are performed with state force equipment and/or hired equipment.
- 6.4.2 Residency personnel should contact the Residency Environmental Specialist and the District Hydraulics Engineer to review any State Force Construction Projects to determine if the proposed work is of a magnitude that may require any drainage or stormwater management improvements, and/or an erosion and sediment control plan. If it is determined that drainage or stormwater management improvements, and/or an erosion and sediment control plan are needed, the same procedures outlined under the SAAP/No Plan Project Plan Development Process shall be followed.

#### 6.5 Plan Development Process for Minimum Plan and Standard Plan Construction Projects

- 6.5.1 Minimum Plan projects are those that require a limited amount of survey information in order to perform the necessary engineering studies and to provide the information required to secure the necessary rights of way. The minimum amounts of detail needed to address environmental requirements and to construct the project are provided in a standard plan assembly format. See Appendix A of the *VDOT Road Design Manual* for additional information on the Minimum Plan concept.
- 6.5.2 Standard Plan Projects are those that require complete survey information in order to perform the necessary detailed engineering studies and to develop a complete and detailed construction plan assembly.
- 6.5.3 Projects developed under the Minimum and Standard Plan concepts must have an ESC plan, and, if required, a SWM Plan (see IIM-LD-195). These plan assemblies should be developed consistent with the steps identified under the Concurrent Engineering Plan Development process described in Section 6.2 of this IIM.

#### 6.5.4 Single Phase ESC Plan Concept

- 6.5.4.1 The Single Phase ESC Plan concept may be used on minor construction projects where all of the erosion and sediment control measures can be clearly depicted on the construction plan sheet (e.g., rural secondary project, minor urban widening project, bridge and approach project, etc.)
- 6.5.4.2 The ESC Plan shall address both those items requiring installation prior to the beginning of grubbing operations or the installation of major drainage structures and those items to be installed as grading operations and installation of minor drainage facilities progress. The ESC Plan shall contain or be accompanied by, at a minimum, all those items identified in the Minimum Requirements for All Erosion and Sediment Control Plans (described in Section 5.4 of this IIM).
- 6.5.4.3 In addition to standard plan symbols, supplemental notes/narratives may be used to clearly define the intent and purpose of the proposed erosion and sediment control measures and to define their sequence of installation. Some standard construction notes and symbols have been developed and are included as a part of the VDOT CADD Cell and Custom Line Style Library and the Geopak Road Plan View Labeler.

#### 6.5.5 Multiple Phase ESC Plan Concept

- 6.5.5.1 The Multiple Phase ESC Plan concept shall be used on construction projects where additional plan sheet(s) are needed in order to clearly depict the erosion and sediment control measures required at the various stages of construction (e.g., rural multi-lane roadway projects, major urban roadway projects, roadway projects on new locations, roadway projects through environmentally sensitive areas, etc.).
- 6.5.5.2 In addition to standard plan symbols, supplemental notes/narratives may be used to clearly define the intent and purpose of the proposed erosion and sediment control measures and to define their installation sequencing. Some standard construction notes and symbols have been developed and are included as a part of the VDOT CADD Cell and Custom Line Style Library and the Geopak Road Plan View Labeler.
- 6.5.5.3 Projects may be developed using the Multiple Phase concept on only those portions of the project that require greater detail and clarity than that provided by the Single Phase concept (e.g., construction in environmentally sensitive areas or major waterway areas, areas where plan clutter reduces the ability to clearly show the erosion and sediment control items, and where grading operations are required

prior to installation of major temporary ESC measures or permanent drainage improvements).

6.5.5.4 At a minimum, the ESC Plan should be developed in two phases:

- Phase I for those items needed to be installed prior to the beginning of grubbing operations or the installation of major drainage structures.
- Phase II for those items to be installed as grading operations and installation of minor drainage facilities progress.

6.5.5.5 Projects with complex grading operations and/or sequence of construction plans may warrant additional ESC Plan Phases to clearly identify all required ESC items.

6.5.5.6 Generally, the Phase I and the Phase II details (including associated narratives or notes) should each be depicted on a separate plan sheet following the applicable construction plan sheet (e.g., Construction Plan Sheet 5, Profile Sheet 5A, ESC Phase I Plan Sheet 5B, ESC Phase II Plan Sheet 5C).

6.5.5.7 When found appropriate, the Phase I and Phase II details may be depicted on a single plan sheet following the applicable construction plan sheet (e.g., Construction Plan Sheet 5, Profile Sheet 5A, ESC Phase I & II Plan Sheet 5B).

6.5.5.8 In general, when utilizing a separate plan sheet for both the Phase I and the Phase II details, erosion and sediment control items (including protective linings in permanent ditches and channel relocations) depicted on the Phase I Plan Sheet should not be duplicated on the Phase II Plan Sheet. Temporary erosion and sediment control items depicted on the Phase I & II Plan Sheets should not be duplicated on the Construction Plan Sheet. Permanent improvements identified to be completed in Phase I, such as drainage structures, should also be shown on the Phase II plan.

6.5.5.9 The ESC Phase I Plan Sheet shall, at a minimum, depict the following:

- Existing contours and appropriate existing hydraulic and topographic features as referenced in the Survey File.
- Proposed centerline, edges of pavement and construction limits.
- Permanent drainage culverts, temporary diversion channels and permanent channel relocations (including any protective linings required) involving natural drainage ways that would be constructed or installed prior to the start of grading operations.

- Temporary Sediment Basins (including grading contours, if applicable) that are to be constructed in the initial phases of the grading operations.
- Stormwater Management Basins (including grading contours, if applicable) that will be utilized as temporary sediment basins and that are to be constructed in the initial phases of the grading operations.
- Diversion dikes, berm ditches and other perimeter ditches (including any required protective linings) that need to be installed prior to the start of grubbing or other earth moving operations.
- Temporary sediment traps, filter barriers, silt fences, rock check dams, turbidity curtains and any other perimeter controls that need to be installed prior to the start of grubbing or other earth moving operations.
- Any necessary construction notes/narratives.

6.5.5.10 The Phase II Plan Sheet shall, at a minimum, depict the following:

- Proposed centerline, edges of pavement and construction limits.
- Any permanent drainage culverts and channel relocations involving natural drainage ways installed under the Phase I Plan.
- Temporary Sediment Basins and Stormwater Management Basins installed under the Phase I Plan.
- All culverts, storm sewer pipe, drop inlets and associated drainage structures that will be installed as grading operations progress.
- All required protective ditch linings (e.g., Standard EC-2 or EC-3, concrete, riprap, etc.), paved flumes and associated structures that will be installed as grading operations progress.
- Temporary sediment traps, slope drains, filter barriers, silt fences, rock check dams, drop inlet silt traps, and any other erosion and sediment control measures needed to be installed as grading operations progress.
- Any necessary construction notes/narratives.

6.5.5.11 The following drainage items from the Phase I and II Plan Sheets shall be depicted on the Construction Plan Sheet:

- Permanent drainage culverts, storm sewer systems, drop inlets and associated structures.
- Permanent channel relocations involving natural waterways.
- Permanent Stormwater Management Facilities.
- Rock Check Dams that will be left in place after construction to serve as a permanent stormwater management structure.

## 7.0 COMPUTATIONS

---

- 7.1 All computations to support the ESC and related SWM Plan, and the drainage design plan, including the drainage area map, shall be developed in accordance with the *VDOT Drainage Manual*, related Informational and Instructional Memoranda (IIM), and Drainage Design Memoranda (DDM), and be made part of the project file.
- 

## 8.0 FIELD REVISIONS AND EVALUATIONS

---

- 8.1 The ESC Plan must be fully and effectively implemented throughout the entire construction phase of the project.
- 8.2 During the construction phase of the project, the Project Engineer, Project Construction Inspector, Environmental Monitor and the contractor shall continuously evaluate the project for areas that may require the deletion/addition/modification of the proposed erosion and sediment control measures in order for the project to remain in compliance with the approved VDOT ESC Standards and Specifications, Virginia ESC Law and Regulations, and VSMP Construction Permit conditions. Changes in the proposed erosion and sediment control measures may be needed due to unforeseen site conditions, contractor scheduling, changes in the proposed sequence of construction or other factors unknown at the time of the development of the proposed ESC Plan.
- 8.2.1 Minor changes to the proposed ESC Plan (e.g., deletion/addition/modification to non-engineered items such as filter barrier, silt fence, check dams, drop inlet silt traps, etc.) may be approved by the VDOT DCR Certified Inspector.
- 8.2.2 When changes to the proposed ESC Plan require detailed hydrologic/hydraulic engineering analysis/calculations (e.g., deletion/addition/modification to engineered items such as sediment traps, sediment basins, etc.), the Project Engineer and/or the Project Inspector should coordinate a site inspection with the District Hydraulics Engineer and/or the ESC Plan Designer/Hydraulics Engineer. The site inspection should be used to assemble detailed notes, sketches, and photographs to formally document the need for ESC Plan changes. The ESC Plan Designer and/or Hydraulics Engineer will provide the appropriate engineering analysis to document the required changes and to ensure the ESC Plan's continued compliance with the approved VDOT ESC Standards and Specifications, Virginia ESC Law and Regulations, and VSMP Construction Permit conditions.
- 8.2.3 Any approved changes to the proposed ESC Plan must be noted on a designated plan set (Record Set) which shall be retained on the project site and made available upon request.

- 8.3 During the construction phase of the project, the Project Engineer, the Project Construction Inspector and/or the Environmental Monitor will periodically (or upon request) provide the ESC Plan Designer and/or Hydraulics Engineer with a detailed evaluation report that notes the success or failure of the proposed erosion and sediment control measures depicted in the construction plans and/or the implementation of different measures as a result of new design technologies. The VDOT ESC Program Administrator (State Hydraulics Engineer) is to be provided a copy of all such reports.
- 

## 9.0 MAINTENANCE

---

- 9.1 Maintenance of the erosion and sediment control items must be continually provided during the duration of the land disturbance activity.
- 9.2 The inspection and maintenance of all temporary and permanent erosion and sediment controls shall be in accordance with Section 107.14 of the VDOT R&B Specifications and Contract Special Provisions S107F and S303E.
- 9.3 Accumulated sediment shall, at a minimum, be removed from erosion and sediment control facilities in accordance with Contract Special Provision S303E.
- 

## 10.0 STANDARD FORMS

---

- |          |   |
|----------|---|
| LD-438   | Guidelines for Development of Erosion and Sediment Control (ESC) and Stormwater Management (SWM) Plans for Projects with Straight Line Sketches |
| LD-439   | Drainage Information Sheet  |
| LD- 445C | Erosion and Sediment Control and Stormwater Management Certification Form   |

For the current version of these forms see the VDOT extranet site:  
<http://www.extranet.vdot.state.va.us/forms/> .



VIRGINIA DEPARTMENT OF TRANSPORTATION

# LOCATION AND DESIGN DIVISION

## INSTRUCTIONAL AND INFORMATIONAL MEMORANDUM

GENERAL SUBJECT: RIPRAP	NUMBER: IIM-LD-73.4
SPECIFIC SUBJECT: STONE DIMENSIONS SOIL SURVEY CONSTRUCTION PROCEDURE	DATE: DECEMBER 1, 2005
	SUPERSEDES: IIM-LD-73.3
DIVISION ADMINISTRATOR APPROVAL: Mohammad Mirshahi, P.E. State L&D Engineer Approved: December 1, 2005	

Changes are shaded.

---

### CURRENT REVISION

- 
- Updated for current Division Administrator Approval.
- 

### EFFECTIVE DATE

- 
- This memorandum will be effective on projects scheduled for the March 1991 advertisement and all subsequent projects.
- 

### POLICY

- 
- The Road and Bridge Specifications allows Riprap that is primarily placed by the dumped method to be measured by Square Yards or Tons.
  - Unless otherwise requested by the District Administrator at field inspection, the measurement should be in Tons to comply with the suppliers method of measurement and expedite final measurement for payment by field personnel.

---

## DIMENSIONS AND WEIGHTS

---

- The following table may be used as a guide for State personnel to correspond certain rock dimensions to equivalent weights. This table is not to be used for acceptance or rejection of Riprap material

APPROXIMATE ROCK DIMENSIONS AND EQUIVALENT WEIGHTS			
WEIGHT	MEAN SPHERICAL DIAMETER	RECTANGULAR SHAPE	
		LENGTH	HT./WIDTH
25 lbs.	0.7'	1.1'	0.4'
50 lbs.	0.8'	1.4'	0.5'
75 lbs.	1.0'	1.6'	0.5'
100 lbs.	1.1'	1.75'	0.6'
150 lbs.	1.3'	2.0'	0.67'
300 lbs.	1.6'	2.6'	0.9'
500 lbs.	1.9'	3.0'	1.0'
1000 lbs.	2.2'	3.7'	1.25'
1500 lbs	2.6'	4.7'	1.5'
2000 lbs.	2.75'	5.4'	1.8'
2 tons	3.6'	6.0'	2.0'
3 tons	4.0'	6.9'	2.3'
4 tons	4.5'	7.6'	2.5'
10 tons	6.1'	10.0'	3.3'

APPROXIMATE PERCENT OF VOIDS	
%	MATERIAL
25	DRY RIPRAP CL.AI
25	DRY RIPRAP CL.I
25	DRY RIPRAP CL.II
25	DRY RIPRAP CL.III
25	DUMPED RIPRAP TY.I
25	DUMPED RIPRAP TY.II
25	EROSION CONTROL STONE
25	GROUTED RIPRAP
25	STONE RIPRAP (CLASSIFICATION SHOWN ON PLANS)

## PROCEDURES

---

- A soil survey is to be conducted through areas where a channel change is proposed and through embankment areas where riprap may be required. The plans or profile rolls for the regular soil survey will show the location of channel changes and the location where Riprap will be required on the fill section.
  - Borings along the proposed channel change are to be taken at sufficient intervals to determine the type of material encountered along the slopes and in the bottom of the channel.
  - The borings made in the cut sections or in the borrow pits for construction of the fills are adequate to determine the type of material used in the fills. The test results on the material used in embankments or along channel changes where Riprap is required should include the Plastic and Liquid Limits of the minus No. 40 sieve and the grading or particle size of the total sample. This information should be submitted in the regular soil survey report.
  - The Project Inspector will visually examine the slope upon which the plans designate Riprap to be placed. If the slope material appears coarser than the bedding aggregate specified, the Project Inspector is to notify the District Material Engineer, through normal channels, for a more detailed investigation to determine the actual need for the bedding. If the slope is comprised of solid rock or closely consolidated boulders with soundness, size and weight equal to or exceeding the specifications, for the proposed Riprap, then the riprap may be deleted by the District Construction Engineer.
- 

## PLANS

---

- The designer shall specify on the plans the type of Riprap and the dimensions (length, width and depth) for placement. The quantity shall be computed using two (2) tons per cubic yard (148 lbs. per cu. ft.) for plan estimating purposes, unless otherwise specified by the District Administrator.
- The quantities will be field adjusted, utilizing the supplier's stone weight and the applicable Percent (%) of Voids for the Type or Class of material used, to obtain the actual quantity.

---

## GENERAL NOTE

---

- The applicable portion of the following general note is to be copied on the plans when riprap is specified. (See IIM-LD-110, Drainage Notes D-11 & D-12)

The proposed riprap may be omitted by the Engineer if the slope upon which the plans designate riprap to be placed is found to meet the following criteria: The slope designated for placement of riprap is comprised of solid rock or closely consolidated boulders with soundness, size and weight equal to or exceed the specifications for the proposed riprap. If the slope is found to be comprised of material, which is coarser than the bedding aggregate filter blanket specified on the plans, the aggregate filter blanket may be deleted by the Engineer.

---

## PAY ITEMS

---

- The Road and Bridge Specifications allow Erosion Control Stone to be measured by the Square Yard or Ton and to include Bedding for Riprap and Riprap Filter Cloth in the price bid for Riprap.

<u>ITEM CODE</u>	<u>DESCRIPTION</u>	<u>UNIT</u>
09150	Erosion Control Stone Class I, Standard EC-1	Ton
09151	Erosion Control Stone Class I, Standard EC-1	Square Yards
09152	Erosion Control Stone Class II, Standard EC-1	Ton
09153	Erosion Control Stone Class II, Standard EC-1	Square Yards

VIRGINIA DEPARTMENT OF TRANSPORTATION

# LOCATION AND DESIGN DIVISION

## INSTRUCTIONAL AND INFORMATIONAL MEMORANDUM

GENERAL SUBJECT: GENERAL NOTES	NUMBER: IIM-LD-110.17
SPECIFIC SUBJECT:	DATE: DRAFT AUGUST 15, 2006
	SUPERSEDES: IIM-LD-110.16
DIVISION ADMINISTRATOR APPROVAL:                      Mohammad Mirshahi, P.E. State Location and Design Engineer Approved August 15, 2006	

Changes are shaded.

---

### CURRENT REVISION

- 
- Revisions have been made the Title Sheet notes and to the Drainage, Stormwater Management and Erosion and Sediment Control General Notes.

---

### EFFECTIVE DATE

- 
- These instructions are effective upon receipt for all projects advertised after November 1, 2006.

---

### GENERAL INSTRUCTIONS

- 
- It is unlikely that any one project will need all of the available general notes. Designers should use only those notes that are applicable. It may be necessary to modify notes and/or supplement notes with additional information.
  - Notes referring to dated materials, such as Specifications or Standards, should be updated when new or revised Specifications or Standards take effect, as applicable.
  - The General Notes are available as CADD cells.

- The Drainage, Erosion and Sediment Control and Stormwater Management General Notes to be used with each project will be determined by the Hydraulics Engineer/ESC Plan Designer. The Hydraulics Engineer/ESC Plan Designer will also be responsible for completing any of these notes where project specific information is required. For examples of information to include in Erosion and Sediment Control Note E-1, see IIM-LD-11.
- Dual Units (Metric and Imperial) are shown for informational purposes.

---

## TITLE SHEET

---

- The following notes (available in the CADD Cell Library) shall be shown in the lower left portion of the Title Sheet prior to Public Hearing:
  - THE COMPLETE ELECTRONIC .TIF VERSION OF THE PLAN ASSEMBLY AS AWARDED, INCLUDING ALL SUBSEQUENT REVISIONS, WILL BE THE OFFICIAL CONSTRUCTION PLANS. FOR INFORMATION RELATIVE TO ELECTRONIC FILES AND LAYERED PLANS, SEE THE GENERAL NOTES.
  - DESIGN FEATURES RELATING TO CONSTRUCTION OR TO REGULATION AND CONTROL OF TRAFFIC MAY BE SUBJECT TO CHANGE AS DEEMED NECESSARY BY THE DEPARTMENT.
  - THIS PROJECT IS TO BE CONSTRUCTED IN ACCORDANCE WITH THE DEPARTMENT'S 2002 ROAD AND BRIDGE SPECIFICATIONS, 2001 ROAD AND BRIDGE STANDARDS, 2005 WORK AREA PROTECTION MANUAL AND AS AMENDED BY CONTRACT PROVISIONS AND THE COMPLETE ELECTRONIC .TIF VERSION OF THE PLAN ASSEMBLY.
  - ALL CURVES ARE TO BE SUPERELEVATED, TRANSITIONED AND WIDENED IN ACCORDANCE WITH STANDARD (see note below) EXCEPT WHERE OTHERWISE NOTED.  
  
Note: Show the appropriate designation: (TC-5.01U, TC-5.01R, TC-5.04ULS).
  - THE ORIGINAL APPROVED TITLE SHEET(S), INCLUDING ORIGINAL SIGNATURES, ARE FILED IN THE VDOT CENTRAL OFFICE PLAN LIBRARY. ANY MISUSE OF ELECTRONIC FILES, INCLUDING SCANNED SIGNATURES, IS ILLEGAL AND ENFORCED TO THE FULL EXTENT OF THE LAW.
  - Show the Critical Infrastructure Information/Sensitive Security Information Note if applicable (See IIM-LD-236).

- For Metric Projects:
  - THIS PROJECT IS TO BE CONSTRUCTED IN ACCORDANCE WITH THE DEPARTMENT'S 1997 ROAD AND BRIDGE SPECIFICATIONS, 1996 ROAD AND BRIDGE STANDARDS, 2005 WORK AREA PROTECTION MANUAL AND AS AMENDED BY CONTRACT PROVISIONS AND THE COMPLETE ELECTRONIC .TIF VERSION OF THE PLAN ASSEMBLY.
- The Classification, Design Traffic Volumes, etc., are to be placed directly under the project number block as shown in the following example:

FUNCTIONAL CLASSIFICATION AND TRAFFIC DATA			
a) MINOR ARTERIAL-DIVIDED-ROLLING-55 MPH MIN. DESIGN SPEED			
	Fr: Rte. 1	Fr: Rte. 640	Fr: Rte. 660
	To: Rte. 640	To: Rte. 660	To: Rte. 301
b)ADT 1996	1840	2700	4180
c)ADT 2018	5080	7320	11300
d)DHV	620	790	1140
e)D (%) (design hour)	55	58	58
f) T (%) (design hour)	5	5	5
g)V (MPH)	*	*	*

\* See Plan and Profile Sheets for horizontal and vertical curve design speeds.

Explanations of the foregoing abbreviations:

- a) Road Functional Classification and Minimum Design Speed for this classification.
- b) ADT = Current (existing) Average Daily Traffic (for informational purposes and Maintenance of Traffic)
- c) ADT = Design Average Daily Traffic anticipated in the design year (See Form LD-104).
- d) DHV = Design Hour Volume
- e) D = Directional Distribution Factor (%) for design hour
- f) T = Percent of trucks (2 axles – 6 tires/3 axles or more) for design hour
- g) V = Design Speed (As shown on the plans by the Location and Design Division to determine the posted speed limit and/or the maximum safe speed.)

---

FIRST PROFILE SHEET

---

- Levels based on \_\_\_\_\_ Datum.

## GRADING GENERAL NOTES

---

G-1 The grade line denotes top of finished pavement unless shown otherwise on typical sections or plans.

The following applicable notes are for use where settlement is uncertain. (Omit notes G-2 and G-3 if project has both Excavation and Embankment set up as pay items.)

- Applicable when the contract is on plan quantity basis:

G-2 Earthwork quantities on this project are based on anticipated settlement and may require adjusting during construction.

- Applicable when the contract is not on plan quantity basis:

G-3 Earthwork quantities on this project are based on anticipated settlement and may require adjusting during construction. Payment will be made only for quantities actually moved.

Non-significant masonry items (e.g. sidewalk, curb and gutter, paved ditch, small footings, small block or brick items, etc.) may be included in regular excavation and designated by the following note:

G-4 The cost of removal of all existing concrete items located in the area to be graded, including, but not limited to the following, shall be included in the price bid for regular excavation: \_\_\_\_\_

When a project has excavation of unsuitable material shown on the plans for a specified depth and undercut excavation is not set up as a bid item, the following note will be used:

G-5 The excavation of unsuitable material as specified on these plans is based on previously conducted subsurface soil investigation. If, during construction, it is deemed necessary to change the depth more than 1 foot (0.3 m) or the limits of such excavation, such change shall be made at the direction of the Engineer and measurement and payment shall be made in accordance with Section 303 of the applicable VDOT Road and Bridge Specifications.

G-6 The borrow material for this project shall be a minimum CBR \_\_\_\_\_ or as approved by the Materials Engineer.

G-7 Material from regular excavation which is suitable for stabilization with hydraulic cement (lime) shall be placed in the top portion of the subgrade.



---

## DRAINAGE GENERAL NOTES

---

- D-1 The horizontal location of all drainage structures shown on these plans is approximate only, with the exception of structures showing specific stations, special design bridges and storm sewer systems.
- D-2 The horizontal location and invert elevations shown for proposed culverts and storm sewer outfall pipes are based on existing survey data and required design criteria. If, during construction, it is found that the horizontal location or invert elevations shown on the plans differ significantly from the horizontal location or elevations of the stream or swale in which the culvert or storm sewer outfall pipe is to be placed, the Engineer shall confer with, and get approval from, the applicable District Drainage Engineer before installing the culvert or storm sewer outfall pipe.
- D-3 The "H" dimensions shown on the plans for drop inlets and junction boxes and the "L.F. (m)" dimensions shown for manholes are for estimating purposes and are based on the proposed invert elevations shown for the structure and the anticipated top (rim) elevation based on existing or proposed finished grade. The actual "H" or "L.F. (m)" dimensions are to be determined by the contractor from field conditions.

The following note is to apply only at specific locations that are designated on the District Administrator's Field Inspection Report. The portion regarding "Excavation For Minor Structures" will apply to single line culvert installations with a diameter or span of 48" (1200 mm) or greater or any multiple line culvert installation with an overall span (out to out) of 48" (1200 mm) or greater.

- D-4 At Station (specify station number), the fill shall be placed and allowed to settle and displace all soft materials. Any necessary temporary drainage shall be installed. When directed by the Engineer, that part of the fill where the permanent drainage structure is to reside shall be removed and the structure placed. The cost of installing and removing the temporary drainage facility, the cost of removing the fill above the original ground for installation of permanent drainage structure and the cost of backfill shall be included in the unit price bid for regular excavation. Excavation below the original ground necessary for the installation of the permanent drainage structure will be measured and paid for in accordance with Section 303 of the applicable VDOT Road and Bridge Specifications.

If the cost of constructing fills is to be paid for as "embankment" make the appropriate change in the previous note.

The following note is to be included for all projects that have locations that require, or allow as an option, Structural Plate Steel Pipe or Pipe Arch with a concrete invert:

D-5 At locations where Structural Plate Steel Pipe or Pipe Arch with a concrete invert is required or is allowable as an option to Corrugated Steel Pipe or Pipe Arch, the concrete invert is to be field applied and shall cover, at a minimum, the bottom 25% of the circumference of a circular shape structure or the bottom and corner plates of an arch shape structure. As an option to providing the concrete invert, the plates along the bottom 25% (minimum) of the circumference of the Structural Plate Steel Pipe or the bottom and corner plates (minimum) of the Structural Plate Steel Pipe Arch shall be a minimum of two sheet thickness (gages) heavier than the sheet thickness (gage) indicated in the applicable VDOT Road and Bridge Standard PC-1 for the specified height of cover for the structure. Example: For a pipe with height of cover requiring 0.109" (2.8 mm) sheet thickness (12 gage) plates, the bottom plates shall be 0.168" (3.5 mm) sheet thickness (8 gage). The sheet thickness (gage) of the remainder of the pipe plates shall either conform to those specified in Standard PC-1 for the applicable height of cover or to the heavier plates used in the bottom of the pipe.

The following note is to be included when multiple types of pipes are allowed (Allowable Pipe Type Table is required):

D-6 Pipes shall conform to any of the allowable types shown on sheet number (specify sheet number), within the applicable height of cover limitations. For strength, sheet thickness, or class designation, available sizes, height of cover limitations and other restrictions for a particular pipe type or height of cover, see the VDOT Road and Bridge Standard PC-1. Structural plate pipe may be substituted for corrugated pipe of the same size and a structural plate pipe arch may be substituted for a corrugated pipe arch of the same size, provided the substitution complies with the applicable sections of the VDOT Road and Bridge Standard PC-1.

The following note is to be included when only one type of pipe is allowed (Allowable Pipe Type Table is not required):

D-7 All pipe on this project shall be (specify type). For strength, sheet thickness, or class designation, available sizes, height of cover limitations and other restrictions for a particular pipe type or height of cover, see the applicable sections of the VDOT Road and Bridge Standards PC-1.

The following note should be included when the plans specify concrete pipe be laid on a radius:

D-8 Where open joint pipe is to be used, no joint shall be opened a distance exceeding 25% of the spigot length. Sealing of the pipe joint shall be in accordance with Section 302 of the applicable VDOT Road and Bridge Specifications.

The following note should be included when the plans specify concrete pipe be laid on a radius and specify a particular pipe joint length:

D-9 A pipe joint length different from that stated on the plans may be used. An adjustment in the percentage of open joint (not to exceed 25% of the spigot length) or amount of bevel shall be made that will obtain the radius stated on the plans. Extra payment for this adjustment will not be allowed. The proposed adjustment shall be approved by the Engineer prior to installation of the pipe line.

The following note is to be included when riprap is specified:

D-10 The proposed riprap may be omitted by the Engineer if the slope designated for placement of riprap is found to be comprised of solid rock or closely consolidated boulders with soundness, size and weight equal to, or exceeding, the specifications for the proposed riprap.

The following note is to be included when a granular filter blanket is used in lieu of geotextile fabric bedding. This does not apply to the aggregate cushion which is placed over the geotextile fabric in certain cases.

D-11 The proposed granular filter blanket for the proposed riprap may be omitted by the Engineer if the slope on which it is to be placed is found to be comprised of material which is coarser than that specified for the proposed granular filter blanket.

D-12 All existing drainage facilities labeled "To Be Abandoned" shall be left in place, backfilled and plugged in accordance with the VDOT Road and Bridge Standard PP-1. Basis of Payment will be C.Y. (m<sup>2</sup>) of Flowable Backfill.

D-13 Existing drainage facilities being utilized as a part of the drainage system, and designated on the plans "To Be Cleaned Out", shall be cleaned as directed by the Engineer. The cost incidental to this shall be included in the contract price for other items.

D-14 Proposed drop inlets with a height (H) less than the standard minimum shown in the VDOT Road and Bridge Standards shall be considered and paid for as Standard Drop Inlets for the type specified.

D-15 Where the plans specify the installation of standard curb drop inlets adjacent to the City of (specify city) Standard Curb and Gutter, the Standard Drop Inlets (as shown in the VDOT Road and Bridge Standards) shall be modified in accordance with details shown on sheet number (specify sheet number). These drop inlets shall be considered and paid for as Standard Drop Inlets for the type specified.

D-16 When Standard CG-6 or CG-7 is specified on a radius (such as at a street intersection), the Engineer may approve a decrease in the cross slope of the gutter to facilitate proper drainage.

---

## PAVEMENT GENERAL NOTES

---

- The following note applies to projects without bridge approach slabs.

- P-1 If any settlement occurs in concrete pavement adjacent to bridges prior to acceptance of the project by the Department, the contractor shall restore the pavement to the original grade either by the mud jack method or by replacing the pavement. In the event the pavement cracks or becomes damaged, it shall be replaced, if directed by the Engineer.
- P-2 The pavement materials on this project will be paid for on a tonnage basis. The weight will vary in accordance with the specific gravity of the aggregates and the asphaltic content of the mix actually used to secure the design depth. The weight of the asphalt concrete is based on 95% of theoretical maximum density. (See IIM-LD-158)

---

## INCIDENTAL GENERAL NOTES

---

On Primary and Secondary projects involving grade crossings to remain in place, show the following notes in the General Notes, on applicable plan sheets and in the summary. Do not include the railroad crossbuck signs in the estimate.

- I-1 Two Reflectorized Railroad Grade Crossing Crossbuck Signs, complete with posts, SHALL BE FURNISHED AND ERECTED BY THE RAILROAD COMPANY.
- I-2 Two Reflectorized Railroad Advance Warning Signs W10-1 complete with two approved posts, WILL BE FURNISHED AND ERECTED BY STATE FORCES.

The following note applies to all projects where access to private property will ultimately be by means of a service road. This note will be on the plans for all applicable projects when submitted for Right of Way Acquisition:

- I-3 Service Roads are to be constructed, and private entrances connected thereto prior to the permanent severing of private entrances by other phases of the proposed construction.
- Principal-Minor Arterial Projects:
- I-4 All trees located within the Clear Zone or within a minimum of 30 feet (9m) of the edge of pavement, within the limits of the right of way or construction easement, unless otherwise noted on plans or directed by the Engineer, shall be removed, as provided for in Section 301 of the applicable VDOT Road and Bridge Specifications.
- Secondary – Collector – Local Projects:
- I-5 That portion of the right of way lying within the Clear Zone or within a minimum of 10 feet (3m), from the edge of pavement or surfacing or within the limits of the construction slopes beyond 10 feet (3m), shall be cleared and grubbed in accordance with the applicable VDOT Road and Bridge Specifications, Section 301, where sufficient right of way or construction easement is provided.

Exceptions:

- I-6 Certain trees shall be preserved as noted on plans or as directed by the Engineer.
- I-7 Where Standard slope roundoffs would damage trees, bushes or other desirable vegetation, they shall be omitted when so ordered by the Engineer.

The following note shall be shown on all applicable plans when submitted for right of way acquisition:

- I-8 All fruit trees between Station \_\_\_\_\_ and Station \_\_\_\_\_, lying within the right of way, shall be removed and destroyed. These trees shall be removed and destroyed as soon as possible after the contractor actually commences work. The cost of this work shall be included in the price bid for clearing and grubbing.

When the following note applies to specific locations on a project, show Sta. \_\_\_\_\_ to Sta. \_\_\_\_\_.

- I-8A Clearing and grubbing shall be confined to those areas needed for construction. No trees or shrubs in ungraded areas shall be cut without the permission of the Engineer. Station \_\_\_\_\_ to Station \_\_\_\_\_.
- I-9 When no centerline alignment is shown for a proposed entrance, the entrance shall be constructed in the same location as the existing entrance.

The following note is to be used on all applicable projects as follows:

- a) Projects using St'd. RM-2 Monuments only – select note I-11 or I-12.
- b) Projects using both St'd. RM-1 and RM-2 Monuments – select notes I-10 and (I-11 or I-12)
- c) Projects using Standard RM-1 only – select note I-10.

- I-10 St'd. RM-1 Right of Way monuments shall be set by the Contractor.
- I-11 St'd. RM-2 right of way monuments will be set by the State Survey Party at the time of stakeout or after construction is complete, if pin location is within construction limits.
- I-12 St'd. RM-2 right of way monuments shall be set by the Contractor.

The following notes will be included in the General Notes when "Reuse Guardrail" is specified in the plans as follows:

- a) Used when the District Administrator desires to retain the guardrail component materials not used by the Contractor in the new construction:
- I-13 Salvaged guardrail materials not used in the new construction shall become the property of the Department and the Contractor shall deliver and store, at no additional cost to the Department, the unused materials at the Department's maintenance yard at (location) during the Department's normal working hours.

- b) Used when the District Administrator does not wish to retain the guardrail component parts not used by the Contractor in the new construction:

I-14 Salvaged guardrail materials not used in the new construction shall become the property of the Contractor and shall be disposed of at a licensed landfill, recycled or be retained by the contractor.

The following note may be used with note I-13 or I-14:

I-15 Where Guardrail Standard GR-2 or GR-8 is shown on the plans and in the summaries, either new guardrail or reused guardrail beam shall be used as provided elsewhere in these plans. The total quantities have been proportioned between new and reuse guardrail based on an estimate of the amount of existing beam that is reusable. The Contractor will be paid for the actual quantities of Guardrail, St'd GR-2 or St'd. GR-8, or Reuse Guardrail St'd. GR-2 or St'd GR-8, as determined by the Engineer.

The following note will be included in the General Notes when the Underground Utilities" survey data on a project has been provided by a consultant. (See IIM-LD-140)

I-16 The "Underground Utilities" survey data on this project has been provided by consultant and copies are available from the Department.

The following note is applicable in accordance with VDOT's Road Design Manual:

I-17 For method of constructing Straight-Line Taper Lanes in Curb and/or Curb and gutter sections, see typical details on Sheet \_\_\_\_\_.

I-18 All pavement markings and traffic flow arrows shown on the roadway construction plans are schematic only. The actual location and application of pavement markings shall be in accordance with Section 704 of the applicable VDOT Road and Bridge Specifications, MUTCD, sequence of construction/traffic control plans, pavement marking plan sheets \_\_\_\_\_ thru \_\_\_\_\_ and as directed by the Engineer.

The following note is applicable to projects having work performed by others:

I-19 The following outside sources, under contract with VDOT, have provided information on this project.

Hydraulic Design	(Show Name of Source)
Roadway Design	" " " "
Utility Design	" " " "
Utility Designation	" " " "
Utility Location	" " " "
Survey	" " " "
Bridge Design	" " " "

If questions or problems arise during construction, please contact the Project Designer. DO NOT CONTACT THE OUTSIDE SOURCES.

The following notes are applicable to all projects:

- I-20 The Official Electronic .tif Version of the plans will override the paper copies or prints of specific layers. Portions of this plan assembly have been CADD generated. To assist in the construction of the project electronic files will be available to the prime contractor during bids and after award of the contract.
- I-21 All electronic plan assemblies will include the construction plans in two formats: .tif files and Microstation format (.dgn) files. Only the .tif files will be considered as part of the official plan assembly.

The Microstation format (.dgn) files are furnished only as information for the contractor. These plans are developed in layers (levels) to aid in readability. However, the construction items may or may not be in the proper layering scheme as described in the VDOT CADD Manual. The Microstation files will only match the scanned files if all required levels are turned on. A Microstation Software license is required to be able to read these files.

---

## STORMWATER MANAGEMENT (SWM) GENERAL NOTES

---

- S-1 CLEARING AND GRUBBING OF SWM BASIN SITE – The area where the dam is to be constructed and the area upstream of the dam, to an elevation equal to the crest of the dam (maximum ponded water elevation), shall be cleared and grubbed in accordance with Section 301 of the applicable VDOT Road and Bridge Specifications.
- S-2 SWM BASIN DAM CONSTRUCTION – The dam for detention basins (no permanent pool) shall conform to the details contained in the plans and shall be constructed in accordance with Section 303 of the applicable VDOT Road and Bridge Specifications. The native material on which the dam will set shall meet the specifications for AASHTO Type A-4 or finer material. Where the native material does not meet this requirement, the area beneath the dam is to be excavated a minimum of 4' (1.2 m) and backfilled with a material meeting the AASHTO Type A-4 or finer classification, unless otherwise specified in the plans. The material used for the embankment of the dam shall be AASHTO Type A-4 or finer or as otherwise specified in the plans. Dams with foundation and embankment material not meeting the above requirements, dams greater than 15' (4.6m) in height, or dams for retention basins (permanent pool) shall incorporate a membrane-lined trench, a homogenous embankment with seepage controls, a zoned embankment or other such approved designs as specified in the plans.
- S-3 SWM BASIN OUTLET PIPE – The pipe culvert under or through the dam for detention basins (no permanent pool) shall be reinforced concrete pipe with rubber gaskets in accordance with Section 232 and 212 of the applicable VDOT Road and Bridge Specifications. A concrete cradle shall extend the full length of the pipe culvert in accordance with the Standard Drawings. The connection between the pipe culvert and the SWM-1 Drainage Structure (or other control structure) shall be made watertight as approved by the Engineer and the cost shall be included in the price bid for the pipe.

- S-4 The SWM-1 Drainage Structure (or other control structure) shall have 4" (100 mm) high numbers and 1" (25 mm) wide stripes painted at 1' (300 mm) intervals as shown on the Standard Drawings or detail sheets. The numbers and stripes are to be installed at the time of the initial installation of the SWM-1 Drainage Structure (or other control structure). Paint and application shall be in accordance with Section 231 and 411 of the applicable VDOT Road and Bridge Specifications and the cost is to be included in the price bid for the applicable structure.
- S-5 All SWM Basins designated for use as temporary sediment basins shall be constructed during the initial phase of earth moving activities or as specified by the plans or directed by the Engineer. During project construction, the SWM-1 Drainage Structure (or other control structure) shall be modified in accordance with the Standard Drawings or plan details in order to provide a temporary sediment basin with both a "wet" storage volume (permanent pool) and a "dry" storage volume. Sediment accumulated in the basin shall be removed when the volume of the "wet" storage (permanent pool) has been reduced by 50%. Sediment shall be disposed of in accordance with Section 106.04 of the applicable VDOT Road and Bridge Specifications. When project construction is complete to a stage where no additional sediment from the project is expected to enter the basin, as determined by the Engineer, the basin shall be cleaned out and restored to the original design elevations, the area stabilized and all temporary modifications to the SWM-1 Drainage Structure (or other control structure) removed.

---

## EROSION AND SEDIMENT CONTROL (ESC) GENERAL NOTES

---

Note: Information related to that noted in parentheses in note E-1 is to be completed based on that for each specific construction/maintenance regulated land disturbing activity. See IIM-LD-11 for examples of the type of information to include.

### E-1 Erosion and Sediment Control Plan Information:

- a. Project Description – (complete with appropriate text)
- b. This project is located in (complete with appropriate County/City) and approximately (complete with appropriate number) acres will be disturbed by the proposed construction/maintenance activity. This project (is/is not) covered under the DCR01 VSMP General Permit For Discharges Of Stormwater From Construction Activities.
- c. The (complete job title and person's name) is designated as the Responsible Land Disturber for this Regulated Land Disturbance Activity.
- d. Critical Areas Adjacent to Project Not Otherwise Identified on the Plans – (complete with appropriate text)
- e. A map depicting existing / proposed contours/drainage patterns is contained in the project drainage file located in the (provide appropriate location).



- f. Off-Site Borrow Areas and/or Surplus Material Disposal Areas Covered By This Erosion and Sediment Control Plan – (complete with appropriate text).
- g. The contractor shall identify locations of potential pollution sources such as vehicle fueling areas, storage areas for fertilizers and chemicals, sanitary waste facilities, etc. and shall develop a stormwater pollution prevention plan for such sites in accordance with Contract Special Provision S107F.
- h. Stormwater run-off from the construction areas of this project will flow into the following streams: (complete with appropriate stream names)
- i. Inspection and maintenance of temporary erosion and sediment control measures will be completed in accordance with the VDOT Road and Bridge Specifications 107.14 and 303.03 and Contract Special Provision S107F.
- j. The following variances to the Department's Approved Erosion and Sediment Control Standards and Specifications have been approved by the Department of Conservation and Recreation: (List any project specific variances that have been authorized by DCR to VDOT's Approved ESC Standards and Specifications. Include a brief description of variance, date approved, and by whom)

E-2 The temporary erosion and siltation control items shown on the Erosion and Sediment Control (ESC) Plan for this project are intended to provide a general plan for controlling erosion and sediment within the project limits. The ESC Plan is based on field conditions at the time of plan development and an assumed sequence of construction for the project. The contractor, in conjunction with the Project Engineer and/or Environmental Monitor, shall adjust the location, quantity and type of erosion and sediment control items required based on the actual field conditions encountered at the time of construction and the actual scheduling and sequencing of the construction activities. Significant changes to the proposed ESC Plan (e.g., those that require an emergency analysis) shall be submitted to the applicable District Hydraulics Engineer for review and approval. Any changes to the proposed ESC Plan must be noted on a designated plan set (Record Set) which shall be retained on the project site and made available upon request.

E-3 The areas beyond the project's construction area are to be protected from siltation. Perimeter controls such as filter barrier, silt fence, diversion dikes, turbidity curtains, etc. shall be installed prior to any grubbing operations or other earth moving activities.

E-4 Temporary earthen structures such as dikes and berms are to be stabilized immediately upon installation. Stabilization may include temporary or permanent seeding, riprap, aggregate, sod, mulching, and/or soil stabilization blankets and matting in conjunction with seeding.

E-5 All channel relocations are to be constructed during the earliest stage of construction and shall be constructed in accordance with all applicable permit requirements and shall be constructed in the dry wherever possible. Stabilization or vegetation shall be established before flow is redirected through the constructed area as directed by the Engineer.

E-6 If the removal of Brush Silt Barrier is specified by the plans or required by the Engineer, the cost of removal and disposal of brush shall be in accordance with Section 109 of the applicable VDOT Road and Bridge Specifications.

E-7 Rock for Check Dams, Drop Inlet Silt Traps, Erosion Control Stone and Riprap shall be in accordance with Section 203 and Section 414 of the applicable VDOT Road and Bridge Specifications.

E-8 The following symbols are used to depict Erosion and Sediment Control items in the plan assembly:

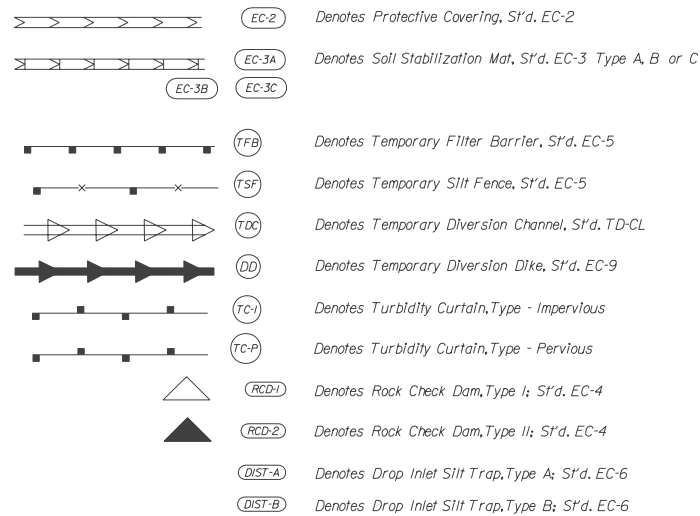

The ESC symbols are to be used to denote proposed erosion and sediment control items on the plans and are available in the CADD Cell and Custom Line Style Libraries and the GeoPak Road Plan View Labels.

The location (sheet number) of the ESC legend is to be noted in the “References” block on each applicable sheet of the plan set.

---

## ELECTRONIC SELECTION OF GENERAL NOTES

---

Microstation has the capability of incorporating the necessary inserts in the General Notes (e.g. sheet number, station, etc.) and also incorporating any additional notes that are required for the project. The General Notes are to be shown for the applicable unit of measurement (Imperial or Metric). General Notes with metric units are denoted by the suffix “M”.

- A General Notes Sheet file is created as follows:
  - Create a file in MicroStation by using the **SEEDGEN.DGN** seed file.

- Ensure that the **LGENNOTE.CEL** is part of the workspace search list for MicroStation cell library. (If you are using the **LD** workspace, then this is already set.)

Type **macro gnote** into the “Key-in Windows”. This will start a MicroStation macro command that will prompt you for information about the General Notes Sheet.

- Select the notes needed, or select the **Select All** button, then de-select the notes that are not needed. The **Add Sp** button will prompt you for additional spaces that you may need between each note header.

VIRGINIA DEPARTMENT OF TRANSPORTATION

# LOCATION AND DESIGN DIVISION

## INSTRUCTIONAL AND INFORMATIONAL MEMORANDUM

GENERAL SUBJECT: ROADSIDE DEVELOPMENT	NUMBER: IIM-LD-122.11
SPECIFIC SUBJECT: ROADSIDE DEVELOPMENT SHEET; COORDINATION; COMPUTING QUANTITIES/SUMMARIZATION	DATE: JANUARY 13, 2005
	SUPERSEDES: IIM-LD-122.10
DIVISION ADMINISTRATOR APPROVAL: Mohammad Mirshahi, PE Approved January 13, 2005	

Changes are shaded.

---

### CURRENT REVISION

- 
- Updated primary points of contact.
  - Added Pay Item for Erosion Control Mulch in S.Y./m2.
- 

### EFFECTIVE DATE

- 
- These instructions are effective upon receipt.
- 

### POLICY

- 
- The Roadside Development Sheet and the Erosion Control Summary Sheet are to be included in project plan assemblies.
  - The Roadside Development Summary will indicate the Asset Management Division's recommended seed mixtures, and estimated quantities for Topsoil, Seeding (Regular and Legume), Fertilizer and Lime.
  - Seed additives (e.g. foxtail millet) are paid for as Regular Seeding except Crown Vetch, Sericea Lespedeza and Birdsfoot Trefoil
  - Seed mixture recommendations may at times deviate from the seed mixture guidelines on the Roadside Development Sheet. The District Roadside Manager will provide recommendations for the application of seed mixtures (core mix and additives), fertilizer, lime, etc.

---

## SPECIAL INSTRUCTIONS

---

- The approximate area (hectares or acres) to be disturbed will be shown under “Notes” on the Roadside Development Sheet. This area is not to be expanded for estimating purposes.
  - Notes on the Roadside Development Sheet marked by a star are for the use of field forces only. The Designer is not to use any percentages shown under “Notes” on the Roadside Development sheet when computing quantities.
- 

## MULCH

---

- Roadside Development involves two categories of mulch as follows:
  - Seeding Mulch, Type I or II is applied in the field with the seed mixture. This mulch is included in the price for the regular seeding and is not summarized in the plans.
  - Erosion Control Mulch is summarized on the Erosion Control Summary Sheet when recommended by the Asset Management Division. This material is estimated at the rate of 0.25 acres (1,210 S.Y.) per 100 feet of alignment or 0.332 hectares (3,319 m<sup>2</sup>) per 100 meters of roadway alignment) and is to be paid for as follows:

<u>PAY ITEM</u>	<u>UNIT</u>	<u>ITEM CODE</u>
Erosion Control Mulch	Acres (Hectare)	27288
Erosion Control Mulch	S.Y. (m <sup>2</sup> )	27284

---

## LEGUME SEEDING

---

- The seed mixes available for roadside development include three “Legume” seeds, Crown Vetch, Sericea Lespedeza and Birdsfoot Trefoil specified as additives “E, F, and G” on the Roadside Development Sheet.
- These Legume seeds are used only on slopes 3:1 or greater and are not used on shoulders or other locations to be mowed.
- Legume Seed, and Legume Overseeding are to be summarized for separate payment.
- Whenever the Asset Management Division specifies any of these Legume seeds, the mowable areas on the project (slopes flatter than 3:1) and non-mowable areas (slopes 3:1 and greater) must be measured separately in order to accurately summarize the seeding requirements.

## ESTIMATING QUANTITIES

- If the lime application rate is not provided by the **Asset Management** Division, the Designer should estimate the Normal Lime Quantity based on 5 metric tons per hectare (2 tons per acre).
- If the fertilizer application rate is not provided by the **Asset Management** Division, the Designer should estimate the Normal Fertilizer Quantity based on 675 kilograms per hectare (600 pounds per acre).
- The seed mixtures (core mix plus additives) shown on the Roadside Development Sheet are weights per hectare (or acre) of disturbed area. These quantities may vary for each construction season.
- The Designer is advised to:
  1. Determine the disturbed area to be seeded.
  2. Determine the application rate for the sloped and mowed areas shown for each construction season.

Example for Seed Mix 2E:

100 lbs. Core Mix + 20 lbs. Additive = 120 lbs.

3. The greatest seeding rate is assumed to be the “Normal” Seeding rate.

Example for 10 acre area:

### MIX REQUIREMENTS ON THIS PROJECT

PROJECT NUMBERS	SLOPES	MOWED	SLOPES	MOWED	SLOPES	MOWED
	SPRING & FALL		SUMMER		LATE FALL & WINTER	
0123-123-103	2E	2B	3A	3A	4B	4B
	120 LBS.	120 LBS.	110 LBS	110 LBS.	120 LBS.	120 LBS.

The Normal Seeding rate = 120 lbs. per acre.

120 lbs. x 10 acres of disturbed area = 1200 lbs. “Normal” Seeding Quantity

- When a legume seed additive is specified (Crown Vetch, Sericea Lespedeza or Birdsfoot Trefoil) the sloped areas and mowed areas must be measured separately when summarizing seeding quantities.
  1. Determine the flat (less than 3:1) areas and sloped (3:1 and greater) areas to be seeded.
 

Example: 10 acres of mowed areas; 5 acres of sloped areas.
  2. Determine the application rate for the mowed areas.

Example for "Seed Mix 2B": 100 lbs. Core Mix + 20 lbs. Additive = 120 lbs.

3. Determine the application rate for the sloped areas:

Example for Seed Mix 2E: Core Mix "2" = 100 lbs.; Additive E" = 20 lbs.

4. Determine the quantities of Regular Seed and Legume Seed.

Example for mowed area (Seed Mix 2B):

Core Mix 100 lbs. + 20 lbs. = 120 lbs. x 10 acres = 1200 lbs. Regular Seed

Example for sloped areas (Seed Mix 2E):

100 lbs. x 5 acres = 500 lbs. Regular Seed

20 lbs. x 5 acres = 100 lbs. Legume Seed

- The "Normal" quantities for lime, fertilizer, and seeding are based on the actual area to be disturbed. The "Normal" quantities are to be increased by the following percentage factors to obtain the quantity to show in the summary:
  - Lime = Normal Quantity increased by 90%
  - Fertilizer (15-30-15)= Normal Quantity increased by 90%
  - Regular Seed = Normal Seeding Quantity increased by 60%
  - Overseeding=100% of Normal Seeding Quantity (no mulch or fertilizer)
  - Legume Seed = Normal Seeding Quantity increased by 60%
  - Legume Overseeding = 100% of Normal Seeding Quantity (no mulch or fertilizer)

Examples for determining quantities to summarize:

20 tons "normal" Lime x 1.90 (or 190%) = 38 tons Lime

3 tons "normal" Fertilizer x 1.90 (or 190%) = 5.7 or 6 tons Fertilizer

1700 lbs."normal" Seeding x 1.60 (or 160%) = 2720 lbs. Regular Seeding

1700 lbs. "normal" Seeding (@ 100%) = 1700 lbs. Overseeding

100 lbs. "normal" Legume Seeding x 1.60 (or 160%)= 160 lbs. Legume Seed

100 lbs. "normal" Legume Seeding (@ 100%) = 100 lbs. Legume Overseeding

## PAY ITEMS

• Lime	Metric Ton/Ton	27250
• Fertilizer	Metric Ton/Ton	27215
• Regular Seed	kg/lbs.	27102
• Overseeding	kg/lbs.	27103
• Legume Seed	kg/lbs.	27104
• Legume Overseeding	kg/lbs.	27105
• Topsoil Class A	ha/acres	27012
• Topsoil Class B	ha/acres	27022
• Erosion Control Mulch	ha/acres/m <sup>2</sup> /S.Y.	27288

## REVIEW BY ASSET MANAGEMENT DIVISION

---

- The Roadside Development Sheet is to be reviewed by the Asset Management Division prior to submission of the plan assembly for construction.
  - Anytime the current Roadside Development Sheet is replaced by a revised Roadside Development Sheet, the District Roadside Manager should be requested to determine the need for any changes in seed mixes, quantities, etc.
- 

## INSERTABLE SHEETS

---

- The Roadside Development Sheet may be obtained through the CADD Insertable Sheet Directory.
  - Special Design Section Drawing No. A-4 (Imperial)
  - Special Design Section Drawing No. MA-4 (Metric)
- The Erosion Control Summary Sheet may be obtained through the CADD Insertable Sheet Directory.
  - Special Design Section Drawing No. A-5 (Imperial)
  - Special Design Section Drawing No. MA-5 (Metric)



VIRGINIA DEPARTMENT OF TRANSPORTATION

# LOCATION AND DESIGN DIVISION

## INSTRUCTIONAL AND INFORMATIONAL MEMORANDUM

GENERAL SUBJECT: SOIL STABILIZATION MAT	NUMBER: IIM-LD-166.4
SPECIFIC SUBJECT: STANDARD EC-3	DATE: DECEMBER 1, 2005
	SUPERSEDES: IIM-LD-166.3
DIVISION ADMINISTRATOR APPROVAL: Mohammad Mirshahi, P.E. State L&D Engineer Approved: December 1, 2005	

Changes are shaded.

---

### CURRENT REVISION

- 
- Updated for current Division Administrator Approval.
- 

### EFFECTIVE DATE

- 
- These instructions are effective on all projects scheduled for the August 1996 advertisement and all subsequent projects.
- 

### POLICY

---

#### Ditches

- Geotextile materials designated as Standard EC-3 (Type A and B) Soil Stabilization Mat are used for protective linings in ditches.
- Standard EC-3 Soil Stabilization Mat is intended to be used as a protective ditch lining material to be applied when the design velocity exceeds the allowable velocity for Standard EC-2 (i.e., jute mesh).

- When the design velocity exceeds the allowable velocity for Standard EC-3, a paved (or riprap) lining will be required.

## Slopes

- The Standard EC-3 (Type C) Soil Stabilization Mat may be used as a protective slope lining for dry cut or fill slopes and wet cut slopes to stabilize the slope on which vegetation is being established. (See Road and Bridge Standards)

---

## TYPES AND APPLICATION

---

### Ditches

- Type A is to be employed where the design (2 year) velocity in the ditch is within the range of 1.2 to 2.1 meters per second (m.p.s.) (4 to 7 f.p.s.)
- Type B is to be employed where the design velocity is within the range of 2.1 to 3.0 m.p.s. (7 to 10 f.p.s.)
- A Manning's "n" value of 0.05 should be used with Standard EC-3.
- Typically, the use of Standard EC-3 Type A should begin at the point where flow velocity exceeds 1.2 m.p.s. (4 f.p.s.) (velocity is assumed to be for flow in an EC-2 lined channel) and continue changing to EC-3, Type B at the appropriate point, until the design velocity exceeds 3.0 m.p.s. (10 f.p.s.) or until such point as the use of a ditch lining can be discontinued.
- Experience has shown that the installation of this material is particularly critical. It must be installed in strict accordance with the standard drawings and manufacturer's specifications.
- It is requested that Standard EC-3 (Type A and B) installations be monitored very closely to determine the validity of the present design criteria. It is recommended that the District Drainage Engineer, in cooperation with appropriate District Environmental and/or maintenance personnel, visit these installations, particularly after significant or intense rainfall events, and prepare a report of their observations which would then be submitted to the Central Office Hydraulics Section on a regular basis until further notice.

---

## PAY ITEMS AND SUMMRIZATION

---

The following items are to be summarized, when applicable, in the Erosion & Sediment Control Summary:

<u>ITEM</u>	<u>UNIT</u>	<u>ITEM CODE</u>
Soil Stabilization Mat EC-3, Type A	m <sup>2</sup> (S.Y.)	27325
Soil Stabilization Mat EC-3, Type B	m <sup>2</sup> (S.Y.)	27326
Soil Stabilization Mat EC-3, Type C	m <sup>2</sup> (S.Y.)	27327

# LOCATION AND DESIGN DIVISION

## INSTRUCTIONAL AND INFORMATIONAL MEMORANDUM

GENERAL SUBJECT: MANAGEMENT OF STORMWATER	NUMBER: IIM-LD-195.5
SPECIFIC SUBJECT: ENGINEERING AND PLAN PREPARATION	DATE: FEBRUARY 12, 2003
	SUPERSEDES: IIM-LD-195.4 DDM 2 (Drainage Manual)
DIVISION ADMINISTRATOR APPROVAL: Mohammad Mirshahi, PE	

---

### CURRENT REVISION

- 
- Guidelines for water quality and quantity control have been clarified in accordance with the Virginia Department of Conservation and Recreation's annual plan review process..
  - Shading has been omitted from this memorandum.
- 

### EFFECTIVE DATE

- 
- This memo is effective upon receipt.
- 

### BACKGROUND

- 
- Acts of the General Assembly have resulted in the issuance of Virginia Stormwater Management (SWM) Regulations and Virginia Erosion and Sediment Control (ESC) Regulations. The general application to highway operations associated with these regulations is addressed in this memorandum. Additional information and instructions for the incorporation of the erosion and sediment details in plan assemblies are contained in the current version of IIM-LD-11.
  - Additional details and examples of the engineering application of the Virginia SWM Regulations in the design of VDOT projects can be obtained from the VDOT Hydraulics Section in any of the various District offices or the Central Office in Richmond.

- Further information regarding the Virginia SWM Regulations or the Virginia ESC Regulations may be obtained from the Virginia Department of Conservation and Recreation (DCR) located at 203 Governor Street, Richmond, VA 23219 or at: <http://www.dcr.state.va.us/sw/index.htm>. Details may also be obtained from the Virginia SWM Handbook (Volume I and II) and the Virginia ESC Handbook published by DCR and available for reference in all VDOT Hydraulics Sections.
- 

## OBJECTIVE

---

### Stormwater Management

- To inhibit the deterioration of the aquatic environment by instituting a stormwater management program that maintains both water quantity and quality post development runoff characteristics, as nearly as practicable, equal to or better than pre-development runoff characteristics.
- 

### Erosion and Sediment Control

- To effectively control soil erosion, sediment deposition, and post development runoff to minimize soil erosion and to prevent any sediment from escaping the project limits.
- 

## CRITERIA

---

### General

- The runoff control provisions of both regulations are complementary and will be addressed under a single set of criteria. The information and instructions contained in this memorandum supersede all previous departmental documents. Where there are conflicts with previous instructions, this memorandum shall take precedence.
- For the applicability of the Virginia Erosion and Sediment Control Regulations see the latest version of IIM-LD-11.
- The Virginia Stormwater Management Regulations are applicable to all state agency projects.
- “State Agency Projects” are those land development activities wherein VDOT has funded any portion of the design, right of way acquisition, or construction including those constructed under the Public/Private Transportation Act (PPTA) and Design/Build projects. Projects, such as subdivision streets, industrial access roads, etc., which are designed and constructed by other parties and which are eligible for acceptance into the state roadway system for maintenance after completion of construction are not considered state agency projects and must conform to

appropriate local regulations. Land development activities occurring within existing VDOT right of way, which are allowed by permit and which are designed, constructed, and funded by other parties, are not considered state agency projects and must conform to appropriate local regulations.

- “Land Development Project” is defined as a manmade change to the land surface that potentially changes its runoff characteristics as a permanent condition. The permanent condition should consider the effects of mature vegetative cover and should not be concerned with temporary changes due to construction activities. The temporary changes are addressed by the ESC regulations.
- 

## Water Quantity Control

---

- Water quantity control shall be governed by the Virginia ESC Regulation MS-19 that requires an adequate receiving channel for stormwater outflows.
- Receiving channels, pipes and storm sewers shall be reviewed for adequacy based upon the following criteria:
  - Natural channels shall be analyzed by the use of a 2-year storm to verify that stormwater will not overtop channel banks or cause erosion of the channel bed and banks.
  - All previously constructed manmade channels shall be analyzed by the use of a 10-year frequency storm to verify that the stormwater will not overtop the banks and analyzed by the use of a 2-year storm to verify that the stormwater will not cause erosion of the bed or banks.
  - Pipes and storm sewer systems shall be analyzed by the use of a 10-year frequency storm to verify that the stormwater will be contained within the pipe or storm sewer system. The receiving channel at the outlet of the pipe or storm sewer shall be analyzed for adequacy of the 2 year storm for natural channels or the 10 year storm for man made channels.
- Water quantity control for the 1 year storm (in lieu of the 2 year storm as required by ESC Regulation MS-19) may be needed if there are existing or anticipated erosion concerns downstream. Control of the 1 year storm requires detaining the volume of runoff from the entire drainage area and releasing that volume over a 24 hour period. The computations are similar to those used for detaining the Water Quality Volume (WQV) and releasing over a 30 hour period. See the DCR SWM Handbook pages 1-23 and 5-38 thru 5-41 for additional information. When the 1 year storm is detained for 24 hours there will be no need to provide additional or separate storage for the WQV if it can be demonstrated that the WQV will be detained for approximately 24 hours. The control of the 1 year storm may require a basin size that is 1.5 to 2 times larger than a basin used to control the increase in the discharge from a 2 year or a 10 year storm.

- Pre-development conditions shall be considered that which exist (or is anticipated to exist) at the time the road plans are approved for right of way acquisition. All land cover shall be assumed to be in good condition regardless of actual conditions existing at the time the analysis is done.
- Impounding structures (dams) that are not covered by the Virginia Dam Safety Regulations shall be checked for structural integrity and floodplain impacts for the 100-year storm event.
- Outflows from stormwater management facilities shall be discharged into an adequate receiving channel as defined by the ESC Regulation MS-19.
- Existing swales being utilized as natural outfall conveyances for pre-development run-off will be considered as channels and, if the swale satisfactorily meets the criteria contained in the ESC Regulation MS-19 for post-development run-off, it will be considered as an adequate receiving channel.
- Construction of stormwater management facilities should be avoided in floodplains. When this is unavoidable, a special examination to determine the adequacy of the proposed stormwater management facilities during the passage of the 10-year flood will be required. The purpose of this analysis is to ensure that the stormwater management facility will operate effectively. The stormwater management facility shall also be examined for structural stability during the passage of the 100-year flood event on the floodplain and shall be examined for any possible impacts caused by the basin on the 100-year flood characteristics of the floodplain. The construction of stormwater management facilities shall be in compliance with all applicable regulations under FEMA's National Flood Insurance Program.
- If it can be demonstrated that the total drainage area to the point of analysis within the receiving channel is 100 times greater than the contributing drainage area within the project site, the receiving channel may be considered adequate, with respect to the channel capacity and stability requirements of the ESC Regulations, without further computations.
- Construction of stormwater management facilities within a sinkhole is prohibited. If stormwater management facilities are required along the periphery of a sinkhole, the design of such facilities shall comply with the guidelines in IIM-LD-228 (Sinkholes) and DCR's Technical Bulletin #2 (Hydrologic Modeling and Design in Karst) and applicable sections of the DCR's SWM Handbook.

---

## Water Quality Control

- A water quality control plan shall be developed for each outfall or watershed where one acre or more of land is disturbed and one acre or greater of impervious area is added.

- At outfalls or watersheds where one acre or more of land is disturbed but less than one acre of impervious area is added, an assessment based on specific site characteristics/limitations shall be made to determine what opportunities exist to enhance water quality.
- Where two or more outfalls flow directly into an adjacent natural or manmade receiving system, or where two or more outfalls converge into one system some distance downstream of the project, the combined additional impervious area of all affected outfalls shall be considered when determining the applicability of VDOT's Annual SWM Plan and the water quality requirements of the Virginia SWM Regulations. The presence of wetlands, perennial streams, natural channels, or other environmentally sensitive areas at the convergence of the outfalls will typically require that the outfall impervious areas be considered in total when assessing the project's water quality impacts. Multiple project outfalls can be considered individually only when the convergence (if applicable) of flows is sufficiently far from the outfalls so as to effectively disconnect the impact of the total combined project impervious area.
- The following comments represent the significant points of the current regulations (the page numbers referenced are those in the DCR SWM Handbook):
  1. BMP (Best Management Practice) requirements for quality control are "Technology Based" (4VAC-3-20-71). The type of BMP required is determined by the percent of area within the project site (right of way and permanent easement) with **new** impervious cover, per outfall. Table 1 shows the relationship of the new impervious cover to the type of BMP required.

<b>TABLE 1*</b> <b>BMP SELECTION TABLE</b>		
Water Quality BMP	Target Phosphorus Removal Efficiency	Percent Impervious Cover**
Vegetated filter strip	10%	16-21%
Grassed swale	15%	
Constructed wetlands	30%	22-37%
Extended detention (2xWQV)	35%	
Retention basin I (3xWQV)	40%	
Bioretention basin	50%	38-66%
Bioretention filter	50%	
Extended detention-enhanced	50%	
Retention basin II (4xWQV)	50%	
Infiltration (1xWQV)	50%	
Sand filter	65%	67-100%
Infiltration (2xWQV)	65%	
Retention basin III (4xWQV with aquatic bench)	65%	

\*Innovative or alternate BMPs not included in this table may be allowed at the discretion of DCR.

\*\*Percent Impervious Cover: Relationship of the area of new impervious cover within the project site (right of way and permanent easement) to the total area of the project site (right of way and permanent easement), per outfall.



2. BMP requirements for flooding or quantity control are determined by the ESC Regulation MS-19 for adequate receiving channels.
3. Extended Detention Basins and Extended Detention Basins Enhanced require a Water Quality Volume (WQV) of 2 x the standard WQV or 1" of runoff from the new impervious area.
4. Extended Detention Basins and Extended Detention Basins Enhanced require a 30 hour drawdown time for the required WQV. The 3" minimum size water quality orifice previously allowed has been eliminated. If the required orifice size is found to be significantly less than 3", an alternative water quality BMP should be investigated for use, such as a linear facility that treats the first flush and allows larger storms to bypass. The calculation procedure for drawdown time and orifice sizing is shown on Pages 5-33 through 5-38 (SWM Handbook) and also in example problems available from VDOT.
5. Sediment Forebays should be used on Extended Detention Basins and Extended Detention Basins Enhanced. The volume of the Forebay should be 0.1" – 0.25" x the new impervious area or 10% of the required detention volume. See Pages 3.04-1 through 5 (SWM Handbook) for details. The overflow spillway shall be stabilized utilizing rip rap, concrete or other non-erodible material.
6. Suggested details for the Extended Detention Basin are shown on Pages 3.07-4 and 5 (SWM Handbook). The riprap lined low flow channel through the basin is not recommended due to maintenance concerns.
7. Suggested details for the Extended Detention Basin Enhanced are shown on Pages 3.07-6 and 7 (SWM Handbook). The geometric design will probably need to be more symmetrical than that shown in order to construct the basin to the dimensions needed.
8. Non-structural practices including, but not limited to, minimization of impervious areas and curbing requirements, open space acquisition, floodplain management, and protection of wetlands may be utilized as appropriate in order to at least partially satisfy the water quality requirements. Approval of such non-structural measures will be secured in advance from the Department of Conservation and Recreation.

---

## MULTI-USE SWM BASINS

---

### Quantity Control – Quality Control – Temporary Sediment Storage

- SWM basins may function as both quantity control and quality control facilities. Some basins may only be needed for quality control. Most swm basins are needed to serve as temporary sediment basins during the construction phase of the project and the design will need to address this dual function. The design that is needed for a permanent swm basin may need to be altered to provide additional temporary sediment storage volume that is in excess of the required WQV. For design purposes the two volumes (WQV and temporary sediment storage volume) should not be added together but rather the larger of the two should govern the basin design.

The additional volume needed for temporary sediment storage may be provided by excavating the bottom of the basin lower than that required for the WQV. The basin's permanent outlet control structure can be temporarily altered to serve as the control structure for the temporary sediment basin (See Standard SWM-DR of VDOT's Road and Bridge Standards and the DCR ESC Handbook). When the project is nearing completion and the basin is no longer needed for temporary sediment control, the basin can be readily converted to the permanent SWM basin by regarding (excavating and/or filling) and removing any temporary control structure appurtenances.

---

## IMPLEMENTATION

---

### Plan Preparation

- Standard and minimum plan projects shall show stormwater management and erosion control measures on the plans as directed in the latest version of IIM-LD-11 and the Road Design Manual.
  - No-plan, SAAP and other types of projects (including maintenance) that do not have a "formal" plan assembly must conform to the requirements of the Virginia Stormwater Management Regulations. For the definition of these types of projects, and the procedures for addressing both the erosion and sediment control and stormwater management requirements on such projects, see the latest version of IIM-LD-11.
- 

### Foundation Data

- Foundation data (a soil boring) for the base of the dam should be requested for all stormwater management basins in order to determine if the native material will support the dam and not allow ponded water to seep under the dam. An additional boring near the center of the basin should also be requested if:
  1. Excavation from the basin may be used to construct the dam, or
  2. Rock may be encountered in the area of excavation, or
  3. A high water table is suspected that may alter the performance of the swm basin.

For large basins, more than one boring for the dam and one boring for the area of the basin may be needed. The number and locations of the borings are to be determined by the Hydraulics Engineer and/or the Materials Engineer.

- The foundation data for the swm basin should be requested by the Hydraulics Engineer at the same time that the request for culvert foundation data is initiated.

## Right of Way

- Permanent stormwater management facilities may be placed in fee right of way or in permanent easements. It is recommended that all permanent stormwater management facilities (dams, ponds, risers, etc.) be placed within fee right of way initially. Ditches and similar features may initially be placed in permanent easements. The final decision on right of way versus permanent easement should be made prior to the Right of Way Stage of the project development process based on information obtained at the Field Inspection meeting and/or the Design Public Hearing. The Department will generally be amenable to the desires of affected landowners in this matter. The multiple use of property for stormwater management and such features as utilities is permissible. The decision on the advisability of such actions must be made on an individual site basis.

## Design Details

- The following details are to be incorporated into the design of VDOT stormwater management basins in order to be in compliance with the Virginia SWM Regulation Revisions of 1998 and the DCR SWM Handbook. These details address concerns with seepage through the dam and along the culvert due to the ponding of water in the basins being of longer duration than previous designs that used a minimum 3" water quality orifice.
  1. Foundation data for the dam is to be secured by the Materials Division in order to determine if the native material will support the dam and not allow ponded water to seep under the dam.
  2. The foundation material under the dam and the material used for the embankment of the dam should be an AASHTO Type A-4 or finer and/or meet the approval of the Materials Division. If the native material is not adequate, the foundation of the dam is to be undercut a minimum of 4' or the amount recommended by the Materials Division. The backfill and embankment material must meet the above soil classification or the design of the dam may incorporate a trench lined with a membrane (such as bentonite penetrated fabric or an HDPE or LDPE liner) and be approved by the Materials Division.
  3. The pipe culvert under or through the dam is to be reinforced concrete pipe with rubber gaskets. Pipe: Specifications Section 232 (AASHTO M170), Gasket: Specification Section 212 (ASTM C443)
  4. A concrete cradle is to be used under the pipe to prevent seepage through the dam. The concrete cradle is to begin at the riser or inlet end of the pipe and extend the full length of the pipe.
  5. If the height of the dam is greater than 15' or if the basin includes a permanent water pool, the design of the dam is to include a homogenous embankment with seepage controls or zoned embankment or similar design in accordance with the DCR SWM Handbook and recommendations of the Materials Division.

6. The top width of the dam should be 10' (3m) minimum to facilitate both construction and maintenance.
  7. The side slopes of the basin should be no steeper than 3:1 to permit mowing and maintenance access.
  8. The longitudinal bottom slope through the basin should be no more than 2% nor less than 0.5%.
  9. The depth of the basin from bottom to the primary outflow point (top of riser, or invert of orifice or weir) should be no more than 3' (1m), if possible, in order to reduce the hazard potential. If the depth needs to be more than about 3' (1m), fencing of the basin site should be considered.
  10. The primary control structure (riser or weir) should be designed to operate in weir flow conditions for the full range of design flows. Where this is not possible or feasible and the control structure will operate in orifice flow conditions at some point within the design flow range, an anti-vortex device, consistent with the design recommendations in the DCR SWM Handbook, shall be utilized.
  11. The length to width ratio of the basin should be about 3:1 (wider at the outlet end). If the ratio is less than about 2:1, and if there is concern that the velocity of flow through the basin will be high, consideration should be given to using baffles within the basin to reduce velocity. Baffles should be constructed of "pervious" type material, such as snow fence, rather than earth berms that tend not to reduce the velocity.
- 

## Perimeter Controls

All SWM basins should be reviewed for the needs of fencing, barricades and no trespassing signs in accordance with the following guidelines:

- Fencing of SWM Basins
  1. Fencing of stormwater management basins is normally not required and should not be considered for most basins due to:
    - Insignificant Hazard - Ponding of water in the basin should only occur with very heavy storms and be noticeable for only a few hours. The ponded depth will normally be no more than about 3' (1m). Ponds and lakes are almost never fenced, even though they may be located in subdivisions and have deep, permanent pools.
    - Limits Maintenance - Fencing will limit maintenance operations and could deter the frequency of maintenance. Fencing could become damaged during major maintenance operations.

2. Fencing of SWM basins may occasionally be needed and should be considered when:
- The basin is deep with ponded depth greater than about 3' (1m) and/or has steep side slopes with 2 or more sides steeper than 3:1, or
  - The basin is in close proximity to schools, playgrounds or similar areas where children may be expected to frequent, or
  - It is recommended on the Field Inspection Report, the Resident Engineer or the City/County (where City/County will take over maintenance responsibility.)

- Barricades

A chain barricade (See Standard CR-1 of VDOT's Road and Bridge Standards) or gate may be needed on some basins to prohibit vehicular access if there is concern with illegal dumping or other undesirable access.

- Signs

"No Trespassing" signs shall be considered for use on all basins, whether fenced or unfenced, and should be recommended, as needed, on the Field Inspection Report.

---

## Regional Facilities

- There are many cases where it is more feasible to develop one major stormwater management facility to control a large watershed area rather than a number of small individual facilities controlling small drainage basins. The concept of regional stormwater management facilities is endorsed by VDOT provided that certain requirements are met.
- Development and use of regional stormwater management facilities must be a joint undertaking by VDOT and the local governing body. The site must be part of a master stormwater management plan developed and/or approved by the local governing body and any agreements related to these facilities must be consummated between VDOT and the local governing body. VDOT may enter into an agreement with a private individual or corporation provided the local governing body has a swm program that complies with the Virginia SWM Regulations and the proper agreements for maintenance and liability of the regional facility have been executed between the local governing body and the private individual or corporation.
- Where the roadway embankment serves as an impounding structure, the right of way line will normally be set at the inlet face of the drainage structure. The local government would be responsible for the maintenance and liabilities outside of the right of way and VDOT would accept the same responsibilities inside the right of way.
- Hydraulic design of regional stormwater management facilities must address any mitigation needed to meet the water quality and quantity requirements of the roadway project. Stormwater management facilities located upstream of the roadway project

shall provide sufficient mitigation for the water quality and quantity impacts of run-off from the roadway project which may bypass the facility.

---

## Maintenance

- Requirements for maintenance of stormwater management facilities, the recommended schedule of inspection and maintenance, and the identification of persons responsible for the maintenance will be addressed in VDOT's "Stormwater Management Annual Plan" as approved by DCR.
- 

## Future Reconstruction

- If a stormwater management facility is constructed to address the water quality and quantity requirements of a current project and, at some time in the future, is displaced to accommodate future roadway construction, the new stormwater management facility constructed at that time must address the water quality and quantity requirements due to the future construction and the water quality and quantity requirements that were mitigated by the original stormwater management facility.
- 

## Reporting

- VDOT is required to submit an annual report to the Department of Conservation and Recreation (DCR) that identifies the location, number and type of stormwater management facilities installed during the preceding year, their storage capacities, the affected water body, and a summary of any water quality monitoring data associated with the facility. A database has been established on the Hydraulics Section's telecommunication file system to record this type of data for all projects. It shall be the responsibility of the district drainage engineer and the hydraulic design engineers in the Central office to ensure that the required information is logged on the database for all stormwater management facilities that are designed for roadway projects. In order for the database to reflect those facilities constructed during the preceding year, it is recommended that the required information be logged at the time of the first submission of plans to the Construction Division. The reporting period will be from July 1 to June 30.
- 

## PLAN DETAILS

---

### Stormwater Management Drainage Structure Standard SWM-1

- To be used at all applicable locations where a riser type of control structure is desired.

### Stormwater Management Dam

- To be used at locations where a wall type control structure is desired (includes modifications to standard endwalls). Normally used for shallow depths of ponding.
  - Details to be provided for individual locations.
- 

Copies of the control structures other than those above shall be submitted to the office of the State Hydraulics Engineer to facilitate future development or modification of standard details.

---

### Stormwater Management Details Standard SWM-DR

- Specify at each location requiring a water quality orifice and/or where modifications are required in order to provide for a temporary sediment basin during the construction phase of the project. The size opening for the water quality orifice or other required openings in the control structure shall be specified in the description for the control structure for each basin.
- 

### Access

- A means of access for inspection and maintenance personnel shall be provided at each SWM facility location. The Standard PE-1 details shown in VDOT's Road and Bridge Standards should be used for vehicular entrances.
  - A turnaround should be provided on each vehicular entrance.
  - Appropriate all weather surface material shall be provided for each vehicular entrance.
- 

### Method of Measurement – Basis of Payment

---

#### Stormwater Management Drainage Structure (SWM-1):

- Basis of payment to be linear feet (meters) measured from invert of structure to top of concrete.

#### Stormwater Management Dam:

- Basis of payment to be cubic yards (m<sup>3</sup>) of Concrete Class A3 Miscellaneous and pounds (kilograms) of Reinforcing Steel.

Grading:

- Excavation for stormwater management basins will be measured and paid for as cubic yards (m<sup>3</sup>) of Stormwater Management Basin Excavation.
- Fill material needed for dams or berms will be measured and paid for as cubic yards (m<sup>3</sup>) of Regular Excavation, Borrow Excavation or Embankment.
- The Grading Diagram is to reflect how the cubic yards (m<sup>3</sup>) of Stormwater Management Basin Excavation and cubic yards (m<sup>3</sup>) of Embankment or Borrow is to be distributed.

Stormwater Management Summary

- All drainage items related to the construction of stormwater management facilities shall be summarized, by location, in the Drainage Summary for the project.
- All incidental items related to the construction of stormwater management facilities shall be summarized, by location, in the Incidental Summary for the project.
- Stormwater Management Excavation and Borrow or Embankment, if needed, is to be included in the totals on the Grading Diagram and Summary.

PAY ITEMS

The following pay items are established:

PAY ITEM	UNIT		ITEM CODE
	Metric	Imperial	
SWM Basin Excavation	m <sup>3</sup>	Cu. Yds.	27545
SWM Drainage Structure (SWM-1)	m	Lin. Ft.	27550

For SWM Dam:

Conc. Cl. A3 Misc.	m <sup>3</sup>	Cu. Yds.	00525
Reinf. Steel	Kg.	Lbs.	00540



## SPECIAL PROVISIONS

---

The current Special Provision/Copied Note for measurement and payment for stormwater management items is available for applicable projects as follows:

<http://www.virginiadot.org/business/manuals-default.asp>

---

## INSERTABLE SHEETS

---

The following insertable sheets (English and Metric) are available on Falcon DMS, under the PPMS# eng-ser, Division, minsert and insert, for insertion into applicable plan assemblies:

- SWM Details – SD/MSD # 2209.
- SWM Drainage Structure (SWM-1) – SD/MSD # 2216.
- SWM Trash Rack – SD/MSD # 2216A

VIRGINIA DEPARTMENT OF TRANSPORTATION

# LOCATION AND DESIGN DIVISION

## INSTRUCTIONAL AND INFORMATIONAL MEMORANDUM

GENERAL SUBJECT: CULVERT DESIGN	NUMBER: IIM-LD-214.2
SPECIFIC SUBJECT:  COUNTERSINKING AND LOW FLOW CONSIDERATIONS FOR SINGLE AND MULTIPLE BARREL CULVERTS	DATE: July 27, 2006
	SUPERSEDES: IIM-LD-214.1
DIVISION ADMINISTRATOR APPROVAL:      Mohammad Mirshahi, P.E. State Location and Design Engineer Approved July 27, 2006	

---

EFFECTIVE DATE

---

- This memorandum is effective upon receipt. Shading has been omitted.

### 1.0 DEFINITIONS

- 1.1 Stream Bed – The substrate along the length of a stream, which lies below the ordinary high water elevation. The substrate may consist of organic matter, bedrock or inorganic particles that range in size from clay to boulders, or a combination of materials. Areas contiguous to the stream bed, but above the ordinary high water elevation, are not considered part of the stream bed.
- 1.2 Culvert – A culvert is generally defined as an enclosed structure that is used to convey surface waters from one side of an embankment to the other. For the purposes of this IIM there is no distinction between temporary and permanent culvert installations.

## 2.0 POLICY

- 2.1 The District Environmental staff will determine if the culvert impacts a jurisdictional stream bed (US Army Corps of Engineers) and will notify the appropriate project authority and the Hydraulic Engineer when the below requirements must be incorporated into the design.
- 2.2 Culverts constructed in jurisdictional stream beds are required to have the upstream and downstream inverts set (countersunk) below the natural stream bed elevation to stimulate natural stream bed establishment within the culvert and to meet the requirements of the environmental permitting process. The countersinking requirement does not apply to floodplain culverts or extensions or maintenance of existing structures where the existing structure will remain in service.
- 2.3 When performing the hydraulic analysis for any culvert installation that is to be countersunk, the analysis shall either:
  - 1) Consider the hydraulic opening as being that above the countersunk portion of the culvert, or
  - 2) Determine the required hydraulic opening (size) based on no countersinking; then specify the next larger size structure (3" or 6" greater height as appropriate) with the additional opening installed below the steam bed.
- 2.4 When performing a hydraulic analysis for any multiple barrel culvert crossing, it is appropriate to consider the natural channel and flood plain configuration as projecting through the crossing, the same as if it were a bridge spanning a flood plain. For the purpose of determining the hydraulic capacity of the crossing, any culvert area that is outside the natural channel area and below the flood plain elevation will be considered obstructed and, therefore, not available for hydraulic conveyance.
- 2.5 Culverts will be adequately sized to allow for the passage of ordinary high water with the countersinking, invert and flood plain restrictions taken into account.
- 2.6 If the culvert is greater than 24" (or equivalent) in diameter, the inlet and outlet ends shall be countersunk a minimum of 6" below the natural stream bed. If the culvert is 24" (or equivalent) or less in diameter, the inlet and outlet ends shall be countersunk a minimum of 3" below the natural stream bed.

### **3.0 MULTIPLE BARREL CULVERTS**

- 3.1 When multiple barrel culverts are used, the 6" countersink requirement may only be needed for one barrel. The Hydraulic Engineer should determine whether it is appropriate and/or feasible to countersink one barrel or all of the barrels considering the following:
  - 3.1.1 Width of Normal Stream - The width of the culvert barrel(s) receiving the low flow should approximate the width of the normal stream to avoid accelerating velocities (at normal flow) through the culvert.
  - 3.1.2 Width of Floodplain - Narrow and constricted floodplains may necessitate all barrels being at the lowest possible elevation. Wide floodplains with significant over bank areas may permit one barrel to be countersunk and the remaining barrels to be either at the floodplain elevation or at an elevation slightly higher than the natural stream bed.
  - 3.1.3 Pipe Culverts – Pipe Culverts may be designed to have barrels at different invert elevations. However, special provisions are needed to ensure proper bedding and backfill. Special Design Endwalls will be required. These considerations may negate any potential cost savings associated with not countersinking all barrels a like amount.
  - 3.1.4 Box Culverts - Precast box culverts may be designed to have barrels at different invert elevations. In doing so, the installation is usually configured with the top of all barrels at the same elevation. This will require the same special considerations for bedding, backfill and endwall design as noted in Section 3.1.3. Cast in place box culverts usually have all barrels of the same size and elevation in order to construct the box culvert using standard details.
- 3.2 Multiple barrel culverts that are constructed with all barrels countersunk shall provide measures for directing the low flow through one or more barrels that approximate the width of the normal stream.
  - 3.2.1 If the normal stream width is approximately equal to the total span of all barrels, low flow diversion measures normally should not be needed. If the Hydraulic Engineer elects not to utilize a low flow diversion structure, the District Environmental Manager shall be notified of the decision and be provided justification in order to advise the environmental review agencies during the permitting process.

- 3.2.2 When low flow diversion measures are needed, they shall be constructed to permit the stream to continue the natural meander or moving process normally associated with flood flows. The low flow diversion structures shall be constructed of rip rap, or other similar material. The rip rap material used should be small enough to allow movement during flood events (i.e., Class I Dry Rip Rap).

See Standard Insertable Sheet isd1588.dgn “Low Flow Diversion for Multiple Line Culvert Installations” for standard low flow diversion details.

- 3.2.3 Other methods of achieving the desired low flow conditions may also be employed. These shall be reviewed and approved by the District Environmental Manager.

## **4.0 SPECIAL CULVERT INSTALLATIONS**

- 4.1 Culverts on Bedrock: If the bedrock prevents countersinking, evaluate the use of a three-sided structure to cross the waterway or evaluate alternative locations for the new culvert that will allow for countersinking. If none of these alternative measures are practicable, the Hydraulic Engineer shall submit documentation to the District Environmental Manager, including the cost, engineering factors, and site conditions that prohibit countersinking the culvert, and shall coordinate the evaluation of options to minimize disruption of the movement of aquatic life. Options that must be considered include partial countersinking (such as less than 3” of countersinking, or countersinking of only one end of the culvert), constructing stone step pools and low rock weirs downstream of the culvert, or other measures that provide for the movement of aquatic life.

NOTE: Blasting of bedrock stream bottoms through the use of explosives is not acceptable as a means of providing for countersinking of pipes on bedrock.

- 4.2 Culverts on Steep Terrain: Culverts on steep terrain (slope of 5% or greater) may generate flow velocities that cause excessive scour at the outlet and may prevent the establishment of a natural bed of material through the culvert. Should this situation present itself, the Hydraulic Engineer shall coordinate the evaluation of alternatives to countersinking. These include partial countersinking of the inlet end and implementation of measures to minimize any disruption of the movement of aquatic life, constructing a stone step/pool structure, using river rock/native stone rather than riprap or constructing low rock weirs to create a pool or pools.

Stone structures should be designed with sufficient-sized stone to prevent erosion or washout and should include keying-in as appropriate. These structures should be designed both to allow for aquatic life passage and to minimize scour at the outlet. The Hydraulic Engineer shall submit documentation to the District Environmental Manager, including the cost, engineering factors, and site conditions that prohibit countersinking the culvert, and shall coordinate the evaluation of options to minimize disruption of the movement of aquatic life.

- 4.3 Culverts at the Confluence of Two Streams: The outlet end of culverts that discharge a tributary directly into another stream must be countersunk below the natural stream bed at the discharge point. If this measure is not practicable, the Hydraulic Engineer shall submit documentation to the District Environmental Manager, including the cost, engineering factors, and site conditions that prohibit countersinking the culvert, and shall coordinate the evaluation of options to minimize disruption of the movement of aquatic life.
- 4.4 Other unusual circumstances that prohibit countersinking shall be evaluated on a case-by-case basis. The Hydraulic Engineer shall submit documentation to the District Environmental Manager, including the cost, engineering factors, and site conditions that prohibit countersinking the culvert, and shall coordinate the evaluation of options to minimize disruption of the movement of aquatic life.
- 4.5 Proposed culverts that do not include countersinking are subject to environmental agency review and approval and may require additional documentation or evaluation of other alternative measures.

VIRGINIA DEPARTMENT OF TRANSPORTATION

# LOCATION AND DESIGN DIVISION

## INSTRUCTIONAL AND INFORMATIONAL MEMORANDUM

GENERAL SUBJECT: SINKHOLES	NUMBER: IIM-LD-228 HM-2002-03
SPECIFIC SUBJECT: GUIDELINES FOR THE DISCHARGE OF STORMWATER AT SINKHOLES	DATE: AUGUST 15, 2002
	SUPERSEDES:
LOCATION AND DESIGN DIVISION APPROVAL: <i>Mohammad Mirshahi, PE</i>	
MATERIALS DIVISION APPROVAL: <i>Andy Mergenmeier, PE</i>	ENVIRONMENTAL DIVISION APPROVAL: <i>Earl T. Robb</i>

---

### EFFECTIVE DATE

---

- These instructions are effective upon receipt.
- 

### PURPOSE

---

- The purpose of these guidelines is to:
  1. Increase awareness of the regulatory requirements for controlling stormwater runoff into sinkholes and identify the applicability of this guidance and the environmental regulations.
  2. Provide design guidance for the discharge of stormwater into sinkholes.
  3. Provide design details for addressing sinkholes directly impacted by the roadway embankment.
  4. Provide guidance to comply with the Environmental Protection Agency (EPA) regulatory requirements to complete an inventory of "improved" sinkholes.
- These guidelines are applicable to roadways and drainage outfall facilities that are constructed and maintained by VDOT and similar facilities that are constructed by others but which will be ultimately maintained by VDOT, such as subdivision streets and associated drainage outfalls.

## BACKGROUND

---

- Sinkholes are found in areas of karst terrain. Karst terrain is generally formed over limestone and dolomite formations. Karst terrains primarily occur within the Valley and Ridge Physiographic Province of western Virginia. Karst type terrains are also known to occur in very limited areas of the Blue Ridge, Piedmont and Coastal Plain Physiographic Provinces of Virginia. While information contained in these guidelines is directed more to those sinkholes located in the Valley and Ridge Physiographic Province, the same considerations should be applied to sinkholes located in other areas of the state.
  - Karst terrain is characterized by closed depressions (sinkholes), caves, and underground drainage resulting from the solutions of the calcium and/or magnesium carbonates. Sinkholes may develop either by solution of the surficial rocks or collapse of underlying caves. The actual rock cavity may or may not be choked by residual soil and debris. It is the potential instability of the sinkhole infilling, most often associated with changes in the local hydrology, which traditionally has been the concern of the construction industry. Those concerns have now broadened to include the potential impacts of construction on the area's hydrology and water quality.
- 

## REGULATIONS

---

- Pursuant to the Safe Drinking Water Act, the Environmental Protection Agency (EPA) regulates the discharge of stormwater runoff into "improved" sinkholes through their Underground Injection Control (UIC) Program. The improvement of sinkholes, and subsequent directing of water into the subsurface, is classified as underground injection. Improved sinkholes used for this purpose are classified as a Class V Underground Injection Wells and may require a permit to function as a recipient of stormwater runoff.
- The EPA classifies the following activities as sinkhole "improvements":
  - Cleaning out a sinkhole to facilitate drainage.
  - Cutting a ditch to the base or mouth of a sinkhole.
  - Piping stormwater runoff to a sinkhole.
  - Cutting brush to facilitate stormwater flow to a sinkhole.
- The EPA does not regulate (i.e., require a permit for) stormwater discharges that flow naturally into sinkholes without modification to the sinkhole.



---

## CONCERNS

---

- Both the EPA and VDOT have concerns with changes to the existing hydrology at sinkhole locations. These concerns include:
- Water Quality – Sinkholes are often direct links to underground sources of drinking water. Stormwater runoff from highways could potentially contain various constituents such as oil, grease, heavy metals and salt that could enter and impact these water supplies. The underground ecosystems could potentially be impacted by highway runoff containing sediment generated both during and following highway construction and material from potential spills resulting from traffic accidents once the highway is operational.
- Water Quantity – Directing additional stormwater flow to a sinkhole can result in the enlargement of the feature, create surface failures and erosion and cause flooding of adjacent property. Increasing the quantity of stormwater runoff flowing to a sinkhole can also cause the characteristics of the sinkhole opening to change in such a manner so as to restrict the flow into the subsurface, resulting in greater surface ponding in and around the area of the sinkhole.
- Instability – The area within and surrounding a sinkhole can settle or sink unexpectedly, resulting in loss of competent structural material and damage to overlying structures.

---

## DESIGN CONSIDERATIONS

---

- The following design considerations must be followed for any projects involving the construction of highways or drainage outfalls in areas where sinkholes are present:
  - Avoidance – Determine if there are any feasible alternatives that would avoid construction in the area of the sinkhole. Where the sinkhole is the natural outfall for the stormwater runoff from the roadway area, determine if the stormwater runoff can be diverted away from the sinkhole to an adequate surface water channel. It should be recognized that drainage facilities to accommodate the diversion of stormwater runoff may require significant additional grading and right of way. In addition, stormwater quantity management facilities may be required at the point where the diverted flow is released from the project right of way in order to avoid the liabilities inherent with stormwater runoff diversion.

- Minimization of Impacts from Direct Discharges – If avoidance is not possible, drainage outfalls from the roadway should include natural buffer zones between the outlet of the roadway drainage structure and the sinkhole in order to provide for a natural filtering process. Where stormwater runoff naturally terminates in sinkhole areas, vegetated flow areas (minimum 80' – 100' in length), runoff spreaders and vegetated swales should be used between the outlet of the roadway drainage structure and the bottom of the sinkhole in order to provide for filtering of the flow. If concentrated flow from the roadway pavement area is being directed into the bottom of the sinkhole, a stormwater management water quality basin or other type of water quality filtering device should be incorporated into the design. The water quality basin or filtering device should not be located in the bottom (throat) of the sinkhole (where the flow enters the ground) but rather should be located as close to the roadway or discharge point as practicable. Stormwater management basins constructed in these areas may require an impermeable lining in order to prevent impacts to the underlining soil and subsurface area. The District Materials Section should provide recommendations regarding this issue. A stormwater management basin may also be needed to provide attenuation of any increased flow quantity that may be directed toward the sinkhole.
  
- If stormwater runoff from a roadway project must be directed to a sinkhole, the area of the sinkhole should be investigated to determine if any existing ponding occurs during rainfall events. The drainage design for the project should reflect how the sinkhole is anticipated to function after completion of the construction activities. The project should be designed to avoid any flood damages resulting from potential blockage and ponding in the sinkhole area.

---

## COORDINATION

---

- During the Scoping Phase of the Plan Development Process, the District Materials Section should identify those projects where visible sinkholes are present along the project corridor. The presence of sinkholes should be noted on Form LD-430, Scoping Report and, if possible, the approximate location of observed sinkholes should be identified. The project survey shall provide an accurate and detailed location and description of all identifiable sinkholes located within the survey boundaries.
  
- During the hydraulic analysis phase of the project development process, the Hydraulics Engineer should coordinate with the District Materials Section and the District Environmental Section if the project Scoping Report or survey data indicates the presence of sinkholes and if it is anticipated that those sinkholes might be impacted by stormwater runoff from the project.

## PLAN DETAILS

---

- Where the roadway traverses over or through a sinkhole area, the sinkhole should be treated in accordance with one of the typical details shown on Standard Insertable Sheet No. isd/msd 2944 unless otherwise directed by the District Materials Engineer.
  - Detail No. 1 should be used for sinkholes that receive stormwater runoff from relatively large areas and have a well-defined opening (throat). This treatment involves cleaning out soil and debris to expose the throat, installing a length of pipe to convey surface drainage into the sinkhole and backfilling with riprap and successive layers of smaller aggregate and a geotextile fabric prior to the placement of the regular roadway embankment material.
  - Detail No. 2 should be used for sinkholes with broad, flat depressions and which have no defined throat. These sinkholes typically receive stormwater runoff from relatively small areas. The width of the roadway embankment is generally less than the width of the depression. This treatment involves the placement of riprap in the bottom of the roadway embankment to allow for the continued infiltration of surface flows. The riprap is capped with successive layers of smaller aggregate and a geotextile fabric before placement of the regular roadway embankment material.
  - Detail No. 3 should be used for small shallow sinkholes that receive stormwater runoff from relatively small areas and where the roadway embankment will cover most or all of the depression. This treatment involves filling the depression with successive layers of smaller aggregate and a geotextile fabric before placement of the regular roadway embankment material. Since this treatment effectively “caps” the sinkhole and precludes the entry of surface water, a drainage ditch or other hydraulic conveyance is typically required along the edge of the roadway embankment to convey stormwater runoff to an adjacent outfall.
- 

## ROADSIDE DITCHES

---

- In areas of karst topography, roadside ditches with a gradient of less than 5% may need to be lined to inhibit the infiltration of surface waters. The District Materials Section should make this determination during the preliminary soils investigation phase of the project and, where applicable, include their recommendations for ditch lining with those other recommendations requested on Form LD-252 - Request for Supporting Data. Where ditch lining is recommended, the roadside ditches should be lined with concrete using Standard PG-2A or PG-5 (as applicable) or similar details. When using Standard PG-2A or PG-5 concrete ditches in these areas, the standard detail drawings will need to be modified to include the following:
  - Add a 30-mil polyethylene film beneath all joints (to extend 4 feet longitudinally in each direction).

- Show the location of the curtain wall (normally placed adjacent to each expansion joint) 4 feet downgrade of the expansion joint (to coincide with the end of the 30-mil polyethylene film).
  - In areas where these modifications apply, the plan description should note "St'd. PG-2A Modified" or "St'd. PG-5 Modified", as applicable. The details for these modifications are included on the Sinkhole Insertable Sheet.
- 

## REPORTING REQUIREMENTS

---

- If direct discharge of runoff into a sinkhole is the only feasible option available and improvements (modifications) such as cleaning, clearing, etc. are needed in the lowest section of the sinkhole (where water enters the ground), the details of such improvements (modifications) must be discussed with the District Environmental Section in order that they can determine what permits and/or reporting will be required. Typical sinkhole improvements (modifications) that would fit into this category are depicted in Detail 1 and Detail 2 on Standard Insertable Sheet No. isd/msd 2944. These "improved" sinkhole sites are to be brought to the attention of the District Environmental Section early in project development process in order to allow adequate time for coordination with the EPA and other applicable regulatory agencies. The Environmental Division's Form EQ-120 must be completed for those sites where it is determined necessary to "improve" a sinkhole and where it is determined such improvements would be regulated under the EPA's UIC Program. The Hydraulics Engineer shall be responsible for completing Form EQ-120 and submitting it to the District Environmental Hazardous Materials Manager for further processing.
- 

## SUBDIVISIONS AND FACILITIES BUILT BY OTHERS

---

- These Guidelines shall apply to roadways that are designed and constructed by others and which will ultimately be maintained by VDOT. In addition, where a sinkhole is being utilized as a drainage outfall, an acceptable legal agreement shall be executed that absolves VDOT of any liability and maintenance responsibilities associated with the sinkhole. The agreement should identify the County as the responsible party in the event that the developer or homeowners association cannot (or will not) assume the responsibility for liability or maintenance. A sample legal agreement can be found in Secondary Roads Division's publication "GUIDE FOR ADDITIONS, ABANDONMENTS, AND DISCONTINUANCES – SECONDARY SYSTEM OF STATE HIGHWAYS". The sample agreement shown in this publication is for stormwater management facilities but it can be modified slightly to cover the use of a sinkhole as a drainage outfall. The development of the agreement for the use of a sinkhole as an outfall should be coordinated with and approved by the Secondary Roads Division in the Central Office.

---

## SUMMARIZATION

---

- Quantities relative to sinkholes (Aggregate Material, Dry Rip Rap, etc.) are to be summarized in a separate summary.
- 

## PAY ITEMS

---

- Standard PG-2A Modified, Paved Ditch, S.Y./m<sup>2</sup>
  - Standard PG-5 Modified, Paved Ditch, S.Y./m<sup>2</sup>
  - 30-mil Polyethylene Film is included in the bid price for Standard PG-2A Modified and/or Standard PG-5 Modified Paved Ditch.
  - Grate for EW-1 is included in the bid price for Standard EW-1 Endwall for Pipe Culverts.
- 

## INSERTABLE SHEET

---

- The following insertable sheets are available on Falcon DMS, under the PPMS# eng\_ser, Division, for applicable plan assemblies:
    - Sinkhole Details, Drawing No. [isd 2944](#) (Imperial), msd 2944 (Metric)
    - Paved Ditch PG-2A/ PG-5 Modified, Drawing No. [isd 2945](#) (Imperial), msd 2945 (Metric)
- 

## FORM EQ-120 SINK HOLE INVENTORY

---

- The Environmental Division maintains Form EQ-120 at the following website:

<http://coweb/environmental/Forms/AllForms.htm>.

VIRGINIA DEPARTMENT OF TRANSPORTATION

# LOCATION AND DESIGN DIVISION

## INSTRUCTIONAL AND INFORMATIONAL MEMORANDUM

GENERAL SUBJECT: VIRGINIA STORMWATER MANAGEMENT PROGRAM	NUMBER: IIM-LD-242
SPECIFIC SUBJECT:  GENERAL VIRGINIA STORMWATER MANAGEMENT PROGRAM (VSMP) CONSTRUCTION PERMIT	DATE: AUGUST 15, 2006
	SUPERSEDES:
DIVISION ADMINISTRATOR APPROVAL:	Mohammad Mirshahi, P.E. State Location and Design Engineer Approved August 15, 2006

---

### EFFECTIVE DATE

---

- This memo is effective upon receipt.
- 

### BACKGROUND

---

- Acts of the General Assembly have resulted in the enactment of the Stormwater Management Law (Section 10.1-603 of the Code of Virginia) and the issuance of the Virginia Stormwater Management Program (VSMP) Permit Regulations (4 VAC 50-60 et seq.) for discharges of stormwater from Regulated Land Disturbing Activities (RLDA). The law empowered the Virginia Soil and Water Conservation Board to regulate, permit, and control stormwater runoff in the Commonwealth and authorized the Board to delegate such powers to the Department of Conservation and Recreation.
- Authorization to discharge under the VSMP Permit Regulations and the Virginia Stormwater Management Act is permitted through the Department of Conservation and Recreation's General Permit, DCR01, which became effective on July 1, 2004 and will expire on June 30, 2009. Coverage under this permit must be applied for prior to beginning any land disturbance on regulated activities.

## APPLICATION

---

- The VSMP General Construction Permit DCR01 is applicable for all RLDA's undertaken by or for VDOT including, but not limited to, RAAP, SAPP, Minimum and No Plan, PPTA and Design Build, Capital Outlay projects and non routine maintenance activities.
- As a condition of the General Permit, a Stormwater Pollution Prevention Plan (SWPPP) must be developed and implemented for the RLDA. For VDOT activities, the SWPPP is comprised of, but not limited to, the Erosion and Sediment Control (ESC) Plan, the Stormwater Management (SWM) Plan and all related Road and Bridge Specifications and Standards (See Special Provision 107F). The SWPPP "must describe and insure the implementation of practices that will be used to reduce the pollutants in stormwater discharges from the construction site." This requirement of the General Permit is met by designing and implementing an ESC and SWM Plan for the RLDA in accordance with VDOT's Approved ESC and SWM Standards and Specifications.
- Coverage under the General Permit is required for all land disturbing activities, except that associated with routine maintenance (See next bullet), that equal or exceed the following land disturbance threshold amounts:

Chesapeake Bay Preservation Areas – 2,500 square feet  
All other areas – 1 Acre

1. The area of land disturbance for any offsite support facilities, such as concrete or asphalt batch plants, equipment staging yards, material storage areas, excavated material disposal areas, borrow areas, etc., associated with the RLDA and identified in the ESC and SWM Plan shall be included in the total calculated land disturbance for the RLDA.
2. In many instances, the locations of the off-site support facilities are not known until after the award of the contract for the RLDA and after the VSMP Permit Registration Process has been completed. The approved ESC & SWM Plan and permit registration for the RLDA will require modification for the inclusion of these activities. (See IIM-LD-11 for additional information for modifying the approved ESC & SWM Plan) A revised VSMP Construction Permit Registration assembly must be completed and resubmitted following the same procedures as for the initial permit registration outlined in this document.
3. In some cases, where the proposed land disturbance activity does not require coverage under the VSMP Permit, the additional disturbed area associated with the offsite support activities identified after the award of the contract, when combined with the total disturbed area for the initial activity, may necessitate the need for coverage under the DCR01 General Permit. Once this is determined, all land disturbing activities shall be halted until coverage under the DCR01

General Permit is secured. An ESC & SWM Plan will need to be prepared for the total RLDA in accordance with the instructions in IIM-LD-11 and IIM-LD-195 and the VSMP Permit Registration application will need to be processed in accordance with the procedures outlined in this document.

- Routine maintenance that is performed to maintain the original line and grade, hydraulic capacity, or original purpose of the facility and disturbs less than five acres of land is exempt from the VSMP Construction Permit requirements.
  1. This exemption is only for those maintenance activities considered routine (e.g., ditch cleaning operations, dressing of shoulders, etc.) and only applies to the Stormwater Management and VSMP Construction Permit Program. It does not apply to the Erosion and Sediment Control Program. An Erosion and Sediment Control Plan (including MS-19 channel adequacy analysis, as appropriate) is required for any land disturbing activity that exceeds the land disturbance thresholds requiring an ESC plan (See IIM-LD-11) regardless of any exemption under the Stormwater Management and VSMP Construction Permit Program.
  2. For any maintenance activity being authorized under this exemption, the activity files should be thoroughly documented as to the original and proposed line, grade, hydraulic capacity and purpose of the facility. Changes effecting hydraulic capacity could include changes to depth, width, side slopes, grade, lining or any other hydraulic characteristic that changes the capacity of the ditch. Likewise, for culverts, changes in size, slope and material may affect the hydraulic capacity.
  3. Where there is any question as to the application of this exemption, the appropriate District Hydraulics Engineer should be consulted.
- Information and instructions for the incorporation of erosion and sediment and stormwater management details in plan assemblies are contained in IIM-LD-11 and IIM-LD-195.

---

## RESPONSIBLE PARTIES

---

- Project Authority
  1. Responsible for initiating the VSMP Construction Permit Registration application process. Completes, or coordinates the completion of, all of the information on the VSMP Construction Permit Registration Information form (LD-445), the Permanent BMP Information form (LD-445A), the VSMP Permit Fee Registration form (LD-445B), attaches the completed ESC & SWM Plan Certification form (LD-445C) and sends the completed assembly for each RLDA to the applicable District VSMP Permit Coordinator.



2. For the purposes of this IIM, the Project Authority is defined as the person with responsibility for oversight of the preliminary engineering aspects of the RLDA such as the Project Manager, the Residency Contract Administrator, or other such person that manages/oversees pre-construction activities of the proposed land disturbing activity.
- ESC Plan Designer/Hydraulic Engineer
    1. Responsible for preparing the ESC and SWM Plan for the RLDA in accordance with VDOT's Approved ESC and SWM Standards and Specifications. Develops and ensures that the applicable information is included in the Erosion and Sediment Control Section of the Plan General Notes for the RLDA, including the applicability of the VSMP Construction Permit (See IIM-LD-110 and IIM-LD-11 for additional information). Assists the Project Authority in completing the VSMP Construction Permit Registration Information form (LD-445) and the Permanent BMP Information form (LD-445A). Submits the completed Erosion and Sediment Control and Stormwater Management Plan Certification form (LD-445C) to the Project Authority.
  - District VSMP Permit Coordinator
    1. Responsible for coordinating the VSMP Construction Permit Registration application process for the District. Collects all of the completed VSMP Permit Registration application assemblies and submits them to the Central Office VSMP Permit Coordinator. Submits the completed VSMP Permit Termination Notice forms (LD-445D) to the Central Office VSMP Permit Coordinator.
    2. The District VSMP Coordinator is the District Drainage Engineer or their designee.
  - Responsible Land Disturber (RLD)
    1. Responsible for insuring the implementation of the ESC and SWM Plan for the RLDA. Completes, signs, and forwards, to the appropriate District VSMP Permit Coordinator, the VSMP Permit Termination Notice form (LD-445D) certifying that final stabilization has been achieved on all portions of the RLDA site.
    2. The RLD is that person so identified on the LD-455 form and is certified under DCR's RLD Certification Program. (See IIM-LD-11 for additional information)
  - Central Office VSMP Permit Coordinator
    1. Responsible for compiling the VSMP Construction Permit Registration assemblies and applying to DCR for coverage under the General Permit for the impending RLDA's. Submits the completed VSMP Construction Permit Registration assemblies, registration fees, and the VSMP Permit Termination Notice form (LD-445D) to DCR. Maintains an online database documenting the RLDA's submitted for coverage.

2. The Central Office VSMP Permit Coordinator is a designated engineer in the Central Office Hydraulics Section.
- 

## DCR01 GENERAL PERMIT REGISTRATION PROCEDURE

---

- The registration process for coverage under the DCR01 General Permit must be completed prior to any land disturbance on activities that exceed the land disturbance thresholds amounts.
- On or before the initiation of the Pre-Advertisement Conference (PAC) process for a RLDA (or other appropriate stage for those activities that do not go through a formal PAC process), the Project Authority shall complete, or have the appropriate person complete, the applicable sections of the VSMP Construction Permit Registration Information form (LD-445), the Permanent BMP Information form (LD-445A), and the VSMP Permit Fee Registration form (LD-445B), attach the ESC and SWM Plan Certification form (LD-445C) and send this assembly to the appropriate District VSMP Permit Coordinator prior to the 21<sup>st</sup> day of each month. For information regarding the process for completing the LD-445C form see IIM-LD-11.
- The District VSMP Permit Coordinator shall review all permit registration assemblies for completeness and forward the completed assemblies to the Central Office VSMP Permit Coordinator on or before the last day of each month. The District VSMP Permit Coordinator will return all incomplete assemblies to the Project Authority for completion and resubmission.
- For Capital Outlay projects, the project authority shall submit the completed permit registration assembly directly to the Central Office VSMP Permit Coordinator in the Central Office Hydraulics Section.
- For PPTA and Design Build projects, the project authority shall submit the completed permit registration assembly to either the District VSMP Permit Coordinator (where the project is being managed in the District) or the Central Office VSMP Permit Coordinator (where the project is being managed in the Central Office).
- The Central Office VSMP Permit Coordinator shall compile all VSMP Permit registration form assemblies received and determine the total fee to be paid to DCR for registering the RLDA's.
- The Central Office VSMP Permit Coordinator shall, by the 7<sup>th</sup> day of each month, submit the VSMP Construction Permit Registration form assemblies, with original signatures, to DCR and shall authorize an Interagency Transfer (IAT) for the combined RLDA registration fees. At the request of DCR, these transactions will only be made on a once a month basis.

- Once DCR receives a complete registration application and appropriate fee, they will issue a registration statement to the Central Office VSMP Permit Coordinator with a project specific registration number for each RLDA. The Central Office VSMP Permit Coordinator will forward the RLDA coverage registration statements to the District VSMP Permit Coordinator or Capital Outlay/PPTA/Design Build Project Authority for distribution to the appropriate RLD. (Note: Since DCR is not currently issuing registration numbers, this portion of the process is waived until further notice. The RLDA is considered covered under the DCR01 General Permit once it has been officially registered with DCR.)
- The Central Office VSMP Permit Coordinator shall submit copies of the LD-445B forms to the Central Office Location and Design Administrative Section in order to debit the appropriate permit registration fees from each specific RLDA.
- The Central Office VSMP Permit Coordinator shall maintain an online database documenting the registered RLDAs and shall retain, on file, copies of the VSMP Construction Permit Registration form assemblies submitted to DCR for a period of not less than 6 months after the completion of the RLDA and the termination of the VSMP Construction Permit Registration.
- Any RLDA missing any of the submission cutoff dates (i.e., to District or Central Office VSMP Permit Coordinator) will have to be carried over to the next month's submission.

---

## CONDITIONS OF COVERAGE UNDER THE DCR01 GENERAL PERMIT

---

- The SWPPP (ESC and SWM Plan and the related standards, specifications and contract documents), along with a copy of the DCR01 General Permit and the registration statement showing the registration number, must be retained on site of the RLDA from the commencement of land disturbance activity to the date of final stabilization. A copy of the DCR01 General Permit is included in Special Provision 107F of the Road and Bridge Specifications or may be obtained from the DCR website at <http://www.dcr.virginia.gov/sw/docs/swm/genper01consact.pdf> . (Note: Since DCR is not issuing registration numbers at this time, the need to retain a copy of the registration statement on site is waived until further notice. The RLDA is considered covered under the DCR01 General Permit once it has been officially registered with DCR.)
- Any modifications to the approved SWPPP must be implemented in accordance with Special Provision 107F, VDOT's Approved ESC and SWM Standards and Specifications, and the procedures outlined in LD-IIM-11.

---

## PROCEDURE FOR TERMINATING COVERAGE UNDER THE DCR01 GENERAL PERMIT

---

- Upon completion of the RLDA, the Responsible Land Disturber (RLD) shall complete and sign the VSMP Permit Termination Notice form (LD-445D) and submit it to the appropriate District VSMP Permit Coordinator prior to the 21<sup>st</sup> day of the month.
- The District VSMP Permit Coordinator shall forward all original signed LD-445D forms to the Central Office VSMP Permit Coordinator on or before the last day of each month.
- The Central Office VSMP Permit Coordinator shall combine all LD-445D forms received and forward them to DCR by the 7<sup>th</sup> day of each month.
- The Central Office VSMP Permit Coordinator will retain a copy of the termination notice on file for a period of not less than 6 months after the completion of the RLDA and record the effective termination date in the online database.

---

## FORMS

---

- LD-445 VSMP Construction Permit Registration Information
- LD-445A Permanent BMP Information
- LD-445B VSMP Permit Fee Registration
- LD-445C ESC and SWM Plan Certification
- LD-445D VSMP Permit Termination Notice

L&D forms are available through the VDOT website and can be downloaded at the following link: <http://www.extranet.vdot.state.va.us/forms/>

# HYDRAULIC DESIGN ADVISORY

## HDA 05-03

DATE: JUNE 21, 2005

### SUBJECT: VDOT's ADOPTION & IMPLEMENTATION OF NOAA ATLAS 14 RAINFALL PRECIPITATION FREQUENCY DATA

AUTHOR: D.M. LEGRANDE, SR.  
ASST. STATE HYDRAULICS ENGINEER

The U.S. National Oceanic & Atmospheric Administration (NOAA) recently released their "ATLAS 14: RAINFALL PRECIPITATION FREQUENCY DATA" which covers the Ohio River basin and surrounding states (including Virginia). This information is most readily and conveniently accessed on NOAA's Internet web site at the following address: [http://hdsc.nws.noaa.gov/hdsc/pfds/orb/va\\_pfds.html](http://hdsc.nws.noaa.gov/hdsc/pfds/orb/va_pfds.html). This new data supercedes and replaces that which is contained in Technical Paper No. 40 "Rainfall frequency atlas of the United States for durations from 30 minutes to 24 hours and return periods from 1 to 100 years" (Hershfield, 1961), NWS HYDRO-35 "Five- to 60-minute precipitation frequency for the eastern and central United States" (Frederick et al., 1977) and Technical Paper No. 49 "Two- to ten-day precipitation for return periods of 2 to 100 years in the contiguous United States" (Miller et al., 1964). All of the rainfall information currently contained in the "VDOT Drainage Manual" was predicated on TP-40 and/or HYDRO-35. All such information is no longer valid.

With the issuance of this Hydraulic Design Advisory, the Department officially recognizes and adopts the data presented in the "ATLAS 14" publication. Henceforth, the Department will require, subject to the guidelines described below, that its implementation of this data be employed for the design of all drainage facilities for which the hydrologic design is customarily predicated on rainfall data. This will include drainage designs for the Department's own facilities as well as those that may ultimately come under the Department's jurisdiction (subdivision streets, etc.). The Department recognizes that it will take some time before everyone becomes familiar with this new information and it can be fully and universally implemented. For this reason, it will be acceptable to continue to use the rainfall data currently in the "VDOT Drainage Manual" for projects under design that have completed the Public Hearing stage prior to the issuance of this Hydraulic Design Advisory.

In using the NOAA Internet web site, it should be noted that there occasionally will be more than one rainfall station located in or near a given county or city. The total point rainfall data displayed will, therefore, be dependent upon where one places the pointer used to make the selection. It is possible to get two or more different sets of total point rainfall data for the same county or city. To avoid confusion and to simplify the implementation and application of the new rainfall data, the Department has developed a set of "B, D, & E" factors for each county and major city throughout the state. These "B, D, & E" factors have been developed for 2, 5, 10, 25, 50, & 100-yr. recurrence interval storm durations. A tabulation of these factors accompanies this Hydraulic Design Advisory. A Microsoft EXCEL spreadsheet containing this same information and which will allow the data to be digitally transferred (i.e. copied and pasted) to other spreadsheets, software data files, etc. is also available for downloading via this web site. The spreadsheet is protected to preclude the possibility of inadvertently changing the data. These "B, D, & E" factors can be employed to determine rainfall intensity through the application of the following equation:

$$I_f = B / (T_c + D)^E$$

Where:

$I_f$  = Rainfall intensity for a given recurrence interval “f”, in inches/hour  
 $T_c$  = Watershed time of concentration (assumed equal to the storm duration), in minutes

In situations where one must determine total point rainfall (as opposed to rainfall intensity) and time of concentration (or storm duration) is usually employed using hours (as opposed to minutes), the above equation can be modified as shown below:

$$R_f = T_{c(h)} (B / (T_{c(m)} + D)^E)$$

Where:

$R_f$  = Total point rainfall for a given recurrence interval “f”, in inches  
 $T_{c(h)}$  = Watershed time of concentration (assumed equal to the storm duration), in hours  
 $T_{c(m)}$  = Watershed time of concentration (assumed equal to the storm duration), in minutes

When employing the new “Atlas 14” rainfall precipitation frequency data, the Department’s published “B, D, & E” factors shall be employed exclusively for the purposes of developing rainfall intensities and total point rainfall values. The use of the “IDF” (intensity-duration-frequency) and “RDF” (total point rainfall-duration-frequency) curves currently shown in the VDOT Drainage Manual shall be discontinued and they will be removed from the Manual at its next revision.

Regarding the impact of the implementation of the “Atlas 14” rainfall precipitation frequency data on computer software, the Department will no longer accept drainage designs from any software package that has not been predicated on this data, subject to the previously noted implementation period. It is our understanding, from communication with the FHWA, that the rainfall database contained in their popular “HYDRAIN” software suite will not be revised to reflect the “Atlas 14” data. The Department will, therefore, no longer accept any computations from the “HYDRAIN” suite that have been predicated on its current rainfall database, subject to the previously noted implementation period. As for software in current use by the Department, the latest version of the GEOPAK software package is being revised to include the “Atlas 14” based “B, D, & E” factors developed by the Department. Appropriate revisions will be distributed as soon as they are available. The following “written-in-house” programs have been revised to incorporate the “Atlas 14” data and the “B, D, & E” factors developed by the Department:

- (1) “DISCHARGE” (for determining peak discharges using the Daniel G. Anderson & Franklin Snyder methods)
- (2) “VIRTOC” (for determining rainfall intensity, time of concentration, and peak discharges using the Rational Formula)
- (3) “RDDITCH” (for determining roadside and median ditch capacity and protective lining requirements)

These programs will be available to both Department and external users via the usual notification and distribution procedures. In addition to the above, new “.RND” (rainfall) files for all counties and major cities have been developed for use with the commercial “EAGLE POINT WATERSHED MODELING” (version

7.0SU-B) software package currently in use by the Department. These “.RND” files are available upon request, as their distribution should not be in violation of Eagle Point’s copyright since one must have the program in order to use them.

Any comments or questions related to this Hydraulic Design Advisory should be directed to

Mr. Roy T. Mills (State Hydraulics Engineer)  
Virginia Department of Transportation  
1401 East Broad Street  
Richmond, Virginia 23219

(via e-mail at) [Roy.Mills@VDOT.Virginia.gov](mailto:Roy.Mills@VDOT.Virginia.gov)

(by phone at) (804) 786-9013

or

Mr. David M. LeGrande, Sr. (Asst. State Hydraulics Engineer)  
Virginia Department of Transportation  
1401 East Broad Street  
Richmond, Virginia 23219

(via e-mail at ) [David.LeGrande@VDOT.Virginia.gov](mailto:David.LeGrande@VDOT.Virginia.gov)

(by phone at) (804) 371-2807

B. D. & E factors for determining rainfall intensity in the Rational and Modified Rational Methods (based on NOAA NW-14 Atlas data)

COUNTY/CITY	#	2-YR			5-YR			10-YR			25-YR			50-YR			100-YR		
		B	D	E	B	D	E	B	D	E	B	D	E	B	D	E	B	D	E
Arlington	00	52.73	11.25	0.83	50.63	10.50	0.77	45.98	9.25	0.72	41.35	7.75	0.66	38.56	7.00	0.61	32.29	5.00	0.55
Accomack	01	65.77	13.00	0.88	56.63	11.50	0.79	49.92	10.00	0.73	39.98	7.50	0.65	37.31	6.50	0.61	32.84	5.25	0.55
Albemarle	02	49.02	10.50	0.82	55.71	11.50	0.80	46.95	9.50	0.73	40.11	7.75	0.66	35.68	6.50	0.61	31.09	5.00	0.55
Alleghany	03	51.16	13.25	0.88	39.11	10.00	0.77	40.84	10.00	0.74	36.37	8.75	0.67	29.66	6.50	0.60	26.46	5.00	0.55
Amelila	04	59.23	12.25	0.86	55.73	11.25	0.79	47.70	9.50	0.73	40.73	7.75	0.66	36.22	6.50	0.61	33.29	5.75	0.56
Amherst	05	60.72	13.00	0.88	57.10	12.00	0.81	43.80	9.25	0.72	39.61	8.00	0.66	34.36	6.50	0.60	30.80	5.25	0.55
Appomattox	06	51.76	11.50	0.84	54.03	11.25	0.80	47.13	10.00	0.73	40.72	8.25	0.67	34.36	6.50	0.60	30.14	5.00	0.55
Augusta	07	46.46	12.25	0.85	44.03	10.75	0.79	41.63	10.00	0.74	32.39	7.25	0.64	32.48	7.25	0.62	27.18	5.25	0.55
Bath	08	46.46	12.25	0.85	47.91	11.50	0.80	38.95	9.50	0.72	34.24	7.75	0.66	30.19	6.25	0.60	28.05	5.50	0.56
Bedford	09	47.85	11.25	0.83	48.76	10.75	0.78	45.55	10.00	0.73	40.49	8.50	0.67	33.51	6.50	0.60	29.36	5.00	0.55
Bland	10	36.34	10.00	0.81	41.14	10.75	0.78	38.52	9.75	0.73	32.99	7.75	0.66	29.71	6.50	0.60	26.71	5.25	0.55
Botetourt	11	51.98	12.25	0.85	51.47	11.50	0.80	44.82	9.75	0.73	36.34	7.50	0.65	33.51	6.50	0.60	29.23	5.00	0.55
Bristol	102	41.68	11.50	0.83	41.14	10.75	0.78	42.11	10.75	0.75	31.43	7.75	0.65	27.32	6.00	0.59	26.45	5.50	0.56
Brunswick	12	62.82	12.25	0.85	55.69	10.50	0.78	49.74	9.25	0.72	41.54	7.25	0.65	40.85	7.00	0.62	33.99	5.00	0.55
Buchanan	13	46.78	11.50	0.85	51.34	12.25	0.82	41.75	9.75	0.74	34.41	7.25	0.65	31.36	6.00	0.60	29.24	5.00	0.56
Buckingham	14	54.24	11.50	0.85	54.80	11.50	0.80	44.53	9.25	0.72	39.48	7.75	0.66	33.09	6.00	0.59	30.63	5.25	0.55
Campbell	15	46.46	12.25	0.85	44.03	10.75	0.79	41.63	10.00	0.74	32.39	7.25	0.64	32.48	7.25	0.62	27.18	5.25	0.55
Caroline	16	65.88	12.75	0.88	58.28	11.50	0.80	51.24	10.00	0.74	39.77	7.25	0.65	36.12	6.25	0.60	32.97	5.25	0.55
Carroll	17	54.24	11.50	0.85	52.48	10.75	0.79	48.34	10.00	0.74	38.91	7.75	0.65	35.14	6.50	0.61	30.77	5.00	0.55
Charles City	18	61.04	11.50	0.85	55.05	10.50	0.77	52.12	9.75	0.73	42.40	7.50	0.65	39.29	6.50	0.61	34.58	5.00	0.55
Charlotte	19	59.23	12.25	0.86	56.63	11.50	0.79	53.27	10.50	0.75	40.16	7.75	0.65	36.03	6.50	0.60	31.51	5.00	0.55
Charlottesville (city)	104	49.02	10.50	0.82	55.71	11.50	0.80	46.95	9.50	0.73	40.11	7.75	0.66	35.68	6.50	0.61	31.09	5.00	0.55
Chesapeake (city)	131	78.62	13.00	0.88	74.36	12.25	0.81	56.41	9.25	0.72	51.18	8.25	0.66	46.33	7.00	0.62	39.60	5.25	0.56
Chesterfield	20	52.72	10.75	0.83	49.08	9.75	0.76	50.71	10.00	0.73	39.77	7.25	0.65	37.31	6.50	0.61	32.29	5.00	0.55
Clarke	21	41.52	8.75	0.82	47.08	9.00	0.80	41.34	7.25	0.73	37.79	5.75	0.67	36.75	5.00	0.64	34.34	4.00	0.59
Craig	22	44.29	11.50	0.84	41.60	10.50	0.77	43.45	10.50	0.75	34.24	7.75	0.66	32.48	7.25	0.62	28.23	5.50	0.56
Culpeper	23	58.30	12.25	0.86	56.46	11.50	0.80	45.25	9.25	0.72	42.03	8.25	0.67	34.33	6.00	0.59	32.38	5.25	0.56
Cumberland	24	60.86	12.75	0.87	56.46	11.50	0.80	46.95	9.50	0.73	36.73	7.00	0.64	33.82	6.00	0.59	32.07	5.50	0.56
Danville (city)	108	50.48	10.50	0.82	39.15	8.75	0.72	35.48	7.75	0.66	33.76	6.75	0.62	33.66	6.25	0.59	34.46	6.00	0.57
Dickenson	25	53.26	12.75	0.87	44.86	10.75	0.79	44.28	10.50	0.75	35.17	7.75	0.65	35.11	7.25	0.62	29.39	5.00	0.55
Dinwiddie	26	61.04	11.50	0.85	57.21	10.75	0.78	54.03	10.00	0.74	44.17	7.75	0.66	40.85	7.00	0.62	34.12	5.00	0.55
Essex	28	61.14	12.00	0.86	59.79	11.50	0.80	51.93	10.00	0.74	41.19	7.50	0.65	40.52	7.25	0.62	33.95	5.25	0.56
Fairfax	29	55.09	11.50	0.84	54.20	11.00	0.79	47.70	9.50	0.73	39.18	7.25	0.65	36.34	6.50	0.60	32.29	5.00	0.55
Fauquier	30	54.24	11.50	0.85	54.80	11.50	0.80	48.34	10.00	0.74	41.03	8.25	0.66	35.44	6.50	0.60	31.38	5.00	0.55
Floyd	31	60.86	12.75	0.87	53.32	10.75	0.79	46.45	9.25	0.72	40.41	7.75	0.65	38.96	7.25	0.62	32.00	5.00	0.55
Fluvanna	32	60.98	12.75	0.88	51.10	10.75	0.79	47.55	10.00	0.74	38.60	7.75	0.65	34.59	6.50	0.61	30.33	5.25	0.55



B. D. & E factors for Virginia for determining rainfall intensity in the Rational and Modified Rational Methods (based on NOAA NW-14 Atlas data)

COUNTY/CITY	#	2-YR			5-YR			10-YR			25-YR			50-YR			100-YR		
		B	D	E	B	D	E	B	D	E	B	D	E	B	D	E	B	D	E
Franklin	33	54.24	11.50	0.85	52.48	10.75	0.79	48.34	10.00	0.74	38.91	7.75	0.65	35.14	6.50	0.61	30.77	5.00	0.55
Frederick	34	44.35	9.50	0.84	45.41	8.50	0.79	43.33	7.75	0.75	37.02	5.75	0.67	35.19	4.75	0.63	33.81	3.75	0.59
Fredericksburg (city)	111	65.52	13.25	0.88	60.63	12.00	0.81	49.92	10.00	0.73	41.35	7.75	0.66	38.56	7.00	0.61	30.46	4.50	0.54
Giles	35	48.45	12.25	0.87	47.31	12.00	0.81	38.52	9.75	0.73	34.13	8.25	0.67	28.63	6.50	0.60	26.45	5.50	0.56
Gloucester	36	60.97	11.50	0.84	60.74	11.25	0.79	53.07	9.50	0.73	43.62	7.50	0.65	40.14	6.50	0.60	35.98	5.25	0.55
Goochland	37	59.23	12.25	0.86	55.73	11.25	0.79	47.70	9.50	0.73	40.73	7.75	0.66	36.22	6.50	0.61	31.51	5.00	0.55
Grayson	38	43.44	11.50	0.84	47.31	12.00	0.81	38.69	9.50	0.73	33.62	7.75	0.66	32.48	7.25	0.62	27.65	5.25	0.55
Greene	39	46.81	10.50	0.82	57.10	12.00	0.81	48.11	10.00	0.74	38.01	7.25	0.65	34.64	6.25	0.61	31.75	5.25	0.56
Greensville	40	56.78	11.25	0.84	55.17	10.75	0.78	52.82	10.00	0.74	41.80	7.50	0.65	38.93	6.50	0.61	34.24	5.25	0.55
Halifax	41	62.13	12.25	0.87	54.16	10.75	0.78	49.92	10.00	0.73	42.69	8.25	0.67	36.22	6.50	0.61	31.60	5.25	0.55
Hampton (city)	114	64.31	11.50	0.85	64.94	11.50	0.80	57.19	10.00	0.74	44.49	7.25	0.64	41.77	6.50	0.60	37.02	5.00	0.55
Hanover	42	55.94	11.50	0.84	53.49	10.75	0.78	47.18	9.25	0.72	39.98	7.50	0.65	36.53	6.50	0.60	32.68	5.25	0.56
Harrisonburg (city)	115	43.01	11.25	0.84	44.71	10.50	0.80	39.71	9.25	0.74	32.17	6.50	0.65	28.85	5.25	0.60	28.34	4.75	0.57
Henrico	43	55.94	11.50	0.84	53.49	10.75	0.78	47.18	9.25	0.72	39.98	7.50	0.65	36.53	6.50	0.60	32.68	5.25	0.56
Henry	44	52.73	11.25	0.83	50.63	10.50	0.77	46.45	9.25	0.72	38.59	7.25	0.65	35.26	6.50	0.60	31.09	5.00	0.55
Highland	45	36.67	10.00	0.81	34.94	8.93	0.74	34.82	8.46	0.71	32.93	7.09	0.66	33.21	6.98	0.64	29.31	6.40	0.59
Isle of Wight	46	71.07	12.25	0.86	65.58	11.25	0.79	54.11	9.25	0.72	47.20	7.50	0.65	46.41	7.25	0.62	38.84	5.25	0.56
James City	47	70.63	12.75	0.87	57.84	10.50	0.78	55.61	10.00	0.74	48.54	8.50	0.67	38.78	6.00	0.59	36.77	5.25	0.56
King George	48	62.71	12.75	0.87	54.16	10.75	0.78	48.93	9.50	0.73	43.35	8.25	0.67	36.12	6.25	0.60	32.92	5.00	0.55
King & Queen	49	65.74	12.75	0.87	49.83	9.75	0.76	50.43	9.50	0.73	44.67	8.25	0.66	37.20	6.25	0.60	32.80	4.75	0.55
King William	50	62.90	12.25	0.86	51.80	10.00	0.77	51.51	10.00	0.73	41.19	7.50	0.65	40.52	7.25	0.62	33.21	5.00	0.55
Lancaster	51	60.12	11.50	0.84	61.61	11.50	0.80	53.83	9.75	0.74	44.47	7.75	0.66	39.83	6.50	0.61	35.83	5.25	0.56
Lee	52	51.05	12.25	0.86	45.70	10.75	0.78	38.28	8.75	0.71	38.78	8.50	0.67	34.62	6.75	0.61	31.95	5.75	0.56
Lexington (city)	117	44.29	11.50	0.84	46.49	11.50	0.79	39.05	9.25	0.72	33.28	7.25	0.65	33.34	7.25	0.62	27.07	5.00	0.55
Loudoun	53	61.40	12.25	0.88	44.34	8.75	0.76	46.93	8.75	0.74	41.48	7.25	0.67	36.12	5.50	0.61	33.25	4.50	0.56
Louisa	54	60.86	12.75	0.87	61.41	12.25	0.82	45.25	9.25	0.72	40.11	7.75	0.66	35.68	6.50	0.61	31.05	5.00	0.55
Lunenburg	55	60.15	12.25	0.85	49.08	9.75	0.76	50.71	10.00	0.73	39.77	7.25	0.65	39.34	7.25	0.62	32.50	5.25	0.55
Lynchburg (city)	118	46.46	12.25	0.85	44.03	10.75	0.79	41.63	10.00	0.74	32.39	7.25	0.64	32.48	7.25	0.62	27.18	5.25	0.55
Madison	56	54.24	11.50	0.85	53.17	10.75	0.79	46.61	9.25	0.73	41.85	8.00	0.67	37.33	6.50	0.62	33.01	5.25	0.57
Martinsville (city)	120	52.73	11.25	0.83	50.63	10.50	0.77	46.45	9.25	0.72	38.59	7.25	0.65	35.26	6.50	0.60	31.09	5.00	0.55
Mathews	57	65.67	12.25	0.86	58.83	10.75	0.78	52.39	9.25	0.72	48.24	8.25	0.67	40.45	6.50	0.60	37.10	5.25	0.56
Mecklenburg	58	60.15	12.25	0.85	49.08	9.75	0.76	50.71	10.00	0.73	39.77	7.25	0.65	39.34	7.25	0.62	32.50	5.25	0.55
Middlesex	59	72.66	13.25	0.88	61.46	11.25	0.79	52.39	9.75	0.73	45.09	7.75	0.66	40.37	6.50	0.61	36.12	5.25	0.56
Montgomery	60	47.29	11.75	0.85	44.20	10.75	0.78	44.28	10.50	0.75	35.12	7.75	0.66	33.34	7.25	0.62	27.24	5.00	0.55
Nelson	62	51.90	11.25	0.84	49.81	10.50	0.77	45.25	9.25	0.72	38.59	7.25	0.65	36.22	6.50	0.61	32.21	5.25	0.56
New Kent	63	62.82	12.25	0.85	55.69	10.50	0.78	49.27	9.25	0.72	43.85	7.75	0.66	41.70	7.25	0.62	34.75	5.25	0.55

B. D. & E factors for Virginia for determining rainfall intensity in the Rational and Modified Rational Methods (based on NOAA NW-14 Atlas data)

COUNTY/CITY	#	2-YR			5-YR			10-YR			25-YR			50-YR			100-YR		
		B	D	E	B	D	E	B	D	E	B	D	E	B	D	E	B	D	E
Newport News (city)	121	64.31	11.50	0.85	64.94	11.50	0.80	57.19	10.00	0.74	44.49	7.25	0.64	41.77	6.50	0.60	37.02	5.00	0.55
Norfolk (city)	122	60.83	11.25	0.84	64.03	11.50	0.80	51.92	9.25	0.72	47.96	8.25	0.66	39.29	6.00	0.59	37.10	5.25	0.56
Northampton	65	61.14	12.00	0.86	51.80	10.00	0.77	50.43	9.50	0.73	41.80	7.50	0.65	40.85	7.00	0.62	34.58	5.25	0.55
Northumberland	66	59.28	11.50	0.85	60.70	11.50	0.80	52.30	10.00	0.73	44.98	8.25	0.66	41.70	7.25	0.62	34.58	5.25	0.55
Nottoway	67	62.14	12.00	0.86	55.67	10.75	0.79	53.53	10.50	0.75	39.77	7.25	0.65	36.11	6.25	0.60	32.50	5.25	0.55
Orange	68	58.30	12.25	0.86	49.81	10.50	0.77	46.95	9.50	0.73	40.11	7.75	0.66	35.68	6.50	0.61	30.10	4.75	0.54
Page	69	39.07	8.50	0.82	41.80	8.25	0.78	40.62	7.50	0.74	38.83	6.50	0.68	32.66	4.50	0.62	34.36	4.50	0.60
Patrick	70	69.66	12.75	0.87	58.05	10.75	0.78	50.00	9.25	0.72	44.80	7.75	0.66	39.29	6.50	0.61	34.89	5.25	0.56
Pittsylvania	71	50.48	10.50	0.82	39.15	8.75	0.72	35.48	7.75	0.66	33.76	6.75	0.62	33.66	6.25	0.59	34.46	6.00	0.57
Powhatan	72	55.09	11.50	0.84	53.32	10.75	0.79	49.13	10.00	0.74	42.03	8.25	0.67	37.41	7.00	0.61	32.74	5.50	0.56
Prince Edward	73	42.34	9.75	0.78	54.20	11.00	0.79	48.19	9.50	0.73	40.73	7.75	0.66	34.33	6.00	0.59	31.56	5.25	0.55
Prince George	74	60.12	11.50	0.84	62.36	11.50	0.80	53.51	10.00	0.74	42.40	7.50	0.65	37.20	6.00	0.59	34.71	5.25	0.55
Prince William	76	52.66	11.50	0.85	46.85	10.00	0.77	47.55	10.00	0.74	40.37	8.25	0.66	35.14	6.50	0.61	31.09	5.25	0.55
Pulaski	77	45.53	12.25	0.86	47.31	12.00	0.81	34.60	8.50	0.71	34.79	8.25	0.67	28.35	6.00	0.59	26.38	5.25	0.55
Rappahannock	78	60.32	12.25	0.87	49.28	9.75	0.78	48.73	9.25	0.74	40.59	7.25	0.66	38.67	6.50	0.62	33.55	4.75	0.56
Richmond	79	62.90	12.25	0.86	59.05	11.50	0.80	53.81	10.00	0.74	44.32	8.25	0.66	39.21	6.75	0.61	34.42	5.25	0.56
Richmond (city)	127	57.69	11.50	0.85	54.99	10.75	0.78	47.91	9.25	0.72	41.66	7.75	0.65	36.88	6.50	0.60	33.15	5.25	0.56
Roanoke	80	47.62	11.50	0.85	47.08	10.75	0.79	47.73	10.75	0.75	38.78	8.50	0.67	34.84	7.25	0.62	29.06	5.25	0.55
Roanoke (city)	128	47.62	11.50	0.85	47.08	10.75	0.79	47.73	10.75	0.75	38.78	8.50	0.67	34.84	7.25	0.62	29.06	5.25	0.55
Rockbridge	81	44.29	11.50	0.84	46.49	11.50	0.79	39.05	9.25	0.72	33.28	7.25	0.65	33.34	7.25	0.62	27.07	5.00	0.55
Rockingham	82	43.01	11.25	0.84	44.71	10.50	0.80	39.71	9.25	0.74	32.17	6.50	0.65	28.85	5.25	0.60	28.34	4.75	0.57
Russell	83	46.78	11.50	0.85	43.36	10.75	0.78	38.95	9.50	0.72	37.76	8.75	0.67	31.10	6.50	0.60	28.76	5.25	0.56
Scott	84	51.20	12.75	0.87	52.43	12.75	0.82	42.17	10.00	0.74	35.47	8.00	0.66	33.34	7.25	0.62	28.29	5.25	0.56
Shenandoah	85	45.21	9.25	0.85	44.82	8.50	0.80	43.22	7.75	0.75	39.74	6.25	0.69	35.16	4.75	0.64	32.71	3.50	0.59
Smyth	86	52.17	12.75	0.87	44.20	10.75	0.78	46.01	10.75	0.75	36.42	8.25	0.66	34.52	7.25	0.62	29.06	5.25	0.55
Southampton	87	67.40	12.25	0.86	65.69	11.50	0.80	54.56	9.50	0.73	44.83	7.50	0.65	41.23	6.50	0.60	38.91	5.75	0.57
Spotsylvania	88	65.52	13.25	0.88	60.63	12.00	0.81	49.92	10.00	0.73	41.35	7.75	0.66	38.56	7.00	0.61	30.46	4.50	0.54
Stafford	89	65.52	13.25	0.88	60.63	12.00	0.81	49.92	10.00	0.73	41.35	7.75	0.66	38.56	7.00	0.61	30.46	4.50	0.54
Staunton (city)	132	46.46	12.25	0.85	44.03	10.75	0.79	41.63	10.00	0.74	32.39	7.25	0.64	32.48	7.25	0.62	27.18	5.25	0.55
Suffolk (city)	133	78.09	12.81	0.88	60.79	10.45	0.77	54.21	9.02	0.72	47.94	7.41	0.65	45.23	6.47	0.62	42.16	5.42	0.58
Surry	90	63.47	11.50	0.85	58.83	10.75	0.78	52.39	9.25	0.72	45.72	7.75	0.66	40.68	6.50	0.60	36.45	5.25	0.55
Sussex	91	60.01	11.25	0.84	78.66	13.25	0.85	54.30	10.00	0.73	46.30	8.25	0.66	42.87	7.25	0.62	35.65	5.25	0.55
Tazewell	92	44.30	12.00	0.85	47.70	12.25	0.82	36.89	9.25	0.73	34.19	8.00	0.66	29.66	6.25	0.60	27.24	5.00	0.55
Virginia Beach (city)	134	61.66	11.25	0.84	61.78	10.75	0.79	56.67	10.00	0.73	49.63	8.25	0.67	40.32	6.00	0.59	37.86	5.25	0.56
Warren	93	44.97	9.50	0.84	44.54	8.75	0.78	41.57	7.75	0.73	39.56	6.50	0.68	33.97	4.75	0.61	34.11	4.25	0.59
Washington	95	41.68	11.50	0.83	41.14	10.75	0.78	42.11	10.75	0.75	31.43	7.75	0.65	27.32	6.00	0.59	26.45	5.50	0.56

B. D. & E factors for Virginia for determining rainfall intensity in the Rational and Modified Rational Methods (based on NOAA NW-14 Atlas data)

COUNTY/CITY	#	2-YR			5-YR			10-YR			25-YR			50-YR			100-YR		
		B	D	E	B	D	E	B	D	E	B	D	E	B	D	E	B	D	E
Westmoreland	96	55.94	11.50	0.84	58.28	11.50	0.80	54.10	10.50	0.75	41.98	7.75	0.66	39.93	7.25	0.62	33.44	5.25	0.55
Williamsburg (city)	137	70.63	12.75	0.87	57.84	10.50	0.78	55.61	10.00	0.74	48.54	8.50	0.67	38.78	6.00	0.59	36.77	5.25	0.56
Winchester (city)	138	44.35	9.50	0.84	45.41	8.50	0.79	43.33	7.75	0.75	37.02	5.75	0.67	35.19	4.75	0.63	33.81	3.75	0.59
Wise	97	53.26	12.75	0.87	44.86	10.75	0.79	44.28	10.50	0.75	36.41	8.00	0.66	35.11	7.25	0.62	29.23	5.00	0.55
Wythe	98	50.79	13.00	0.88	44.18	11.25	0.80	42.97	10.75	0.75	35.80	8.25	0.67	31.03	6.50	0.61	28.29	5.25	0.56
York	99	69.54	12.75	0.87	58.89	10.75	0.78	55.09	10.00	0.73	45.72	7.75	0.66	40.68	6.50	0.60	38.41	5.75	0.57

# HYDRAULIC DESIGN ADVISORY

## HDA 05-04.1

DATE: JULY 28, 2005, REVISED SEPTEMBER 14, 2006

SUBJECT: Application of NRCS' "TR-55" and "TR-20" Hydrologic Computations Using NOAA ATLAS 14 Rainfall Data

AUTHOR: D.M. LeGrande, Sr.  
Asst. State Hydraulics Engineer

This HDA supplements Hydraulic Design Advisory HDA 05-03, issued 06/21/05 & revised 07/18/05. When using hydrologic computational methods based on 24-hr. point rainfall such as the National Resource Conservation Service's (NRCS) "TR-55" and "TR-20" or other methods predicated on the application of NRCS' procedures, it will be necessary to use NOAA's "ATLAS-14" Rainfall Precipitation Frequency Data. This will be required whenever these hydrologic computational methods are employed in drainage designs for Department projects or those that will ultimately come under the Department's jurisdiction. This takes effect with the issuance of this Hydraulic Design Advisory. Exceptions in the case of projects already underway are outlined in HDA 05-03.

The 24-hr. Rainfall Depths table for Virginia, presented in the VDOT DRAINAGE MANUAL in Chapter 11, Appendix 11C-3, has been revised to reflect the NOAA "ATLAS-14" data for the 1 to 100-yr. rainfall frequency events. The revised table will be included in the next formal revision to the VDOT DRAINAGE MANUAL. A copy of the revised table is attached to this Hydraulic Design Advisory.

Recent discussions with the Virginia Department of Conservation & Recreation (DCR) have confirmed that they will accept the NOAA "ATLAS-14" Rainfall Precipitation Frequency data as presented herein for regulatory purposes in lieu of the older, NRCS-based tables presented in their handbook.

Any comments or questions related to this Hydraulic Design Advisory should be directed to

Mr. Roy T. Mills (State Hydraulics Engineer)  
Virginia Department of Transportation  
1401 East Broad Street  
Richmond, Virginia 23219

(via e-mail at) [Roy.Mills@VDOT.Virginia.gov](mailto:Roy.Mills@VDOT.Virginia.gov)

(by phone at) (804) 786-9013

or

Mr. David M. LeGrande, Sr. (Asst. State Hydraulics Engineer)  
Virginia Department of Transportation  
1401 East Broad Street  
Richmond, Virginia 23219

(via e-mail at ) [David.LeGrande@VDOT.Virginia.gov](mailto:David.LeGrande@VDOT.Virginia.gov)

(by phone at) (804) 371-2807

**APPENDIX 11C-3**

**24-HR. RAINFALL DEPTHS (INCHES)**

COUNTY	FREQ. (YRS.)						
	1	2	5	10	25	50	100
Accomack	2.7	3.4	4.4	5.3	6.6	7.8	9.1
Albemarle	3.0	3.7	4.7	5.6	6.8	7.9	9.1
Alleghany	2.2	2.7	3.4	4.0	4.8	5.5	6.3
Amelia	2.7	3.3	4.2	5.0	6.2	7.1	8.2
Amherst	2.8	3.5	4.4	5.2	6.4	7.4	8.5
Appomattox	2.8	3.4	4.4	5.2	6.4	7.4	8.5
Arlington	2.6	3.2	4.1	4.8	6.1	7.1	8.4
Augusta	2.4	2.9	3.6	4.3	5.2	5.9	6.7
Bath	2.5	3.0	3.8	4.4	5.3	6.1	7.0
Bedford	2.8	3.4	4.3	5.1	6.3	7.3	8.4
Bland	2.1	2.6	3.1	3.5	4.1	4.5	4.9
Botetourt	2.6	3.4	4.3	5.1	6.2	7.2	8.2
Brunswick	2.8	3.4	4.3	5.1	6.3	7.2	8.2
Buchanan	2.2	2.6	3.2	3.7	4.4	5.0	5.6
Buckingham	2.8	3.4	4.3	5.1	6.3	7.3	8.4
Campbell	2.8	3.3	4.3	5.0	6.2	7.1	8.2
Caroline	2.7	3.3	4.2	5.0	6.3	7.4	8.6
Carroll	2.7	3.3	4.2	5.0	6.0	6.9	7.8
Charles City	2.8	3.4	4.4	5.3	6.5	7.6	8.8
Charlotte	2.7	3.3	4.2	5.0	6.1	7.1	8.1
Chesapeake (city)	3.0	3.7	4.7	5.6	7.0	8.1	9.4
Chesterfield	2.8	3.4	4.3	5.1	6.3	7.3	8.4
Clarke	2.3	2.8	3.5	4.1	4.9	5.6	6.4
Craig	2.3	2.8	3.6	4.2	5.1	5.8	6.6
Culpeper	2.7	3.3	4.3	5.1	6.3	7.4	8.6
Cumberland	2.7	3.3	4.2	5.0	6.1	7.1	8.1
Dickenson	2.2	2.6	3.2	3.7	4.5	5.1	5.7
Dinwiddie	2.8	3.4	4.4	5.2	6.4	7.4	8.4
Essex	2.7	3.2	4.2	5.0	6.3	7.4	8.7
Fairfax	2.6	3.2	4.1	4.9	6.1	7.2	8.5
Fauquier	2.6	3.1	4.0	4.8	5.9	7.0	8.2
Floyd	2.9	3.6	4.5	5.4	6.6	7.6	8.7
Fluvanna	2.7	3.2	4.1	4.9	6.0	6.9	8.0
Franklin	2.8	3.4	4.4	5.2	6.4	7.4	8.5
Frederick	2.4	2.9	3.6	4.2	5.0	5.7	6.5
Giles	2.3	2.7	3.4	3.9	4.6	5.3	5.9
Gloucester	2.9	3.5	4.6	5.5	6.8	7.9	9.2
Goochland	2.7	3.3	4.2	5.0	6.1	7.1	8.2
Grayson	2.1	2.5	3.2	3.7	4.5	5.1	5.8
Greene	3.0	3.5	4.5	5.3	6.6	7.6	8.7
Greensville	2.7	3.3	4.3	5.1	6.2	7.1	8.1
Halifax	2.7	3.2	4.1	4.9	6.0	6.9	7.9
Hampton (city)	2.9	3.6	4.6	5.5	6.9	8.0	9.3

**APPENDIX 11C-3**

**24-HR. RAINFALL DEPTHS (INCHES)**

COUNTY	FREQ. (YRS.)						
	1	2	5	10	25	50	100
Hanover	2.7	3.3	4.2	5.0	6.3	7.4	8.6
Henrico	2.7	3.3	4.2	5.0	6.3	7.4	8.6
Henry	2.9	3.5	4.4	5.2	6.4	7.4	8.5
Highland	2.4	2.9	3.6	4.2	5.1	5.8	6.5
Isle of Wight	3.0	3.6	4.7	5.6	6.9	8.0	9.2
James City	2.9	3.6	4.6	5.5	6.8	8.0	9.2
King & Queen	2.7	3.3	4.2	5.1	6.3	7.4	8.7
King George	2.6	3.2	4.1	4.9	6.2	7.3	8.5
King William	2.7	3.3	4.2	5.1	6.3	7.4	8.6
Lancaster	2.7	3.3	4.3	5.2	6.5	7.6	8.9
Lee	2.7	3.2	3.9	4.5	5.3	6.0	6.8
Loudoun	2.6	3.1	4.0	4.7	5.9	6.9	8.0
Louisa	2.7	3.3	4.2	5.0	6.2	7.2	8.3
Lunenburg	2.7	3.3	4.2	5.0	6.1	7.1	8.2
Madison	2.8	3.4	4.4	5.2	6.4	7.4	8.5
Mathews	2.8	3.5	4.5	5.4	6.7	7.9	9.2
Mecklenburg	2.7	3.3	4.2	4.9	6.0	7.0	8.0
Middlesex	2.8	3.4	4.4	5.3	6.6	7.8	9.0
Montgomery	2.3	2.8	3.5	4.1	5.0	5.8	6.6
Nelson	3.1	3.7	4.7	5.6	6.9	8.0	9.2
New Kent	2.8	3.4	4.4	5.2	6.5	7.6	8.8
Newport News (city)	2.9	3.6	4.6	5.5	6.9	8.0	9.3
Norfolk (city)	3.0	3.6	4.6	5.5	6.8	8.0	9.2
Northampton	2.7	3.3	4.3	5.2	6.5	7.7	9.0
Northumberland	2.7	3.3	4.3	5.1	6.4	7.6	8.8
Nottoway	2.7	3.3	4.2	5.0	6.2	7.1	8.2
Orange	2.8	3.3	4.3	5.1	6.3	7.3	8.4
Page	3.0	3.6	4.6	5.4	6.6	7.7	8.8
Patrick	3.2	3.9	5.0	5.9	7.2	8.4	9.7
Pittsylvania	2.8	3.3	4.2	5.0	6.1	7.1	8.1
Powhatan	2.7	3.3	4.2	4.9	6.1	7.1	8.1
Prince Edward	2.7	3.3	4.2	5.0	6.2	7.2	8.2
Prince George	2.8	3.4	4.4	5.2	6.4	7.4	8.5
Prince William	2.5	3.0	3.9	4.6	5.8	6.8	8.0
Pulaski	2.0	2.4	3.0	3.5	4.2	4.8	5.5
Rappahannock	2.8	3.4	4.3	5.0	6.1	7.1	8.1
Richmond	2.7	3.3	4.3	5.1	6.4	7.5	8.8
Roanoke	2.7	3.2	4.1	4.8	5.9	6.8	7.7
Rockbridge	2.4	2.9	3.6	4.3	5.2	6.0	6.8
Rockingham	2.2	2.6	3.3	3.9	4.7	5.4	6.1
Russell	2.3	2.7	3.3	3.7	4.4	4.9	5.5
Scott	2.3	2.7	3.3	3.8	4.4	4.9	5.4
Shenandoah	2.3	2.8	3.5	4.0	4.9	5.6	6.3

**APPENDIX 11C-3****24-HR. RAINFALL DEPTHS (INCHES)**

---

COUNTY	FREQ. (YRS.)						
	1	2	5	10	25	50	100
Smyth	2.3	2.6	3.2	3.6	4.2	4.6	5.1
Southampton	2.9	3.5	4.5	5.4	6.6	7.7	8.8
Spotsylvania	2.7	3.2	4.1	4.9	6.1	7.2	8.4
Stafford	2.6	3.2	4.1	4.9	6.1	7.2	8.4
Suffolk (city)	3.0	3.6	4.7	5.6	6.9	8.1	9.3
Surry	2.9	3.5	4.6	5.5	6.7	7.9	9.1
Sussex	2.9	3.5	4.5	5.3	6.5	7.5	8.5
Tazewell	2.1	2.5	3.0	3.4	4.0	4.4	4.9
Virginia Beach (city)	3.0	3.7	4.7	5.7	7.0	8.2	9.4
Warren	2.5	3.0	3.8	4.4	5.3	6.1	7.0
Washington	2.2	2.6	3.0	3.4	3.9	4.2	4.6
Westmoreland	2.6	3.2	4.2	5.0	6.3	7.4	8.6
Wise	2.3	2.7	3.3	3.8	4.6	5.2	5.9
Wythe	2.1	2.5	3.1	3.6	4.2	4.8	5.3
York	2.9	3.6	4.6	5.5	6.9	8.1	9.4

---

Source: NOAA Atlas 14 Precipitation Frequency Estimates, Vol. 2, Version 2.1, 2005 & Version 3.0, 2006



# HYDRAULIC DESIGN ADVISORY

## HDA 06-03

DATE: AUGUST 14, 2006

SUBJECT: CULVERT OUTLET PROTECTION  
ROAD AND BRIDGE STANDARD EC-1

SUPERSEDES: SECTION 8.3.2.6 OF THE 2002 VDOT DRAINAGE MANUAL

AUTHOR: STEPHEN D. KINDY, P.E.  
ASST. STATE HYDRAULICS ENGINEER

A review of our current culvert outlet protection practices has indicated that a greater emphasis on the existing soil type is warranted to: 1) insure protection of the downstream channel or swale where material or lining in the downstream channel or swale may be unstable (erodible) under the anticipated velocities exiting the culvert, and 2) insure protection of the culvert end by providing measures to prevent the formation of a scour hole at the culvert outlet.

The type of material in the swale/channel at culvert outlets will need to be determined based on observations or field borings secured in accordance with the guidance found in Drainage Design Memorandum 1 (DDM1), Drainage Design Instructions, located in Chapter 15 of the VDOT Drainage Manual. The allowable velocity for natural material can be found in the table shown in Appendix 7D-2 of the VDOT Drainage Manual. The guidelines and procedures presented herein shall be implemented on all VDOT projects that: 1) have not progressed past the Right-of-Way stage or 2) have not progressed beyond the Pre-Advertisement Conference where right-of-way or easement will not be impacted or 3) will not result in any impacts to any conditions of secured water quality permits.

Highlights of the new procedures/details are:

1. Maintains current rip rap sizes for outlet velocities 8 fps and greater
2. Establishes new riprap size for outlet velocities up to 8 fps
3. Allows the use of EC-3 Type B for velocities less than 6 fps
4. Maintains current apron dimensions for culvert installations with a total hydraulic opening of less than 7 square feet.
5. Increases apron length to five times the height of the culvert for culvert installations with a total hydraulic opening of 7 square feet or greater.
6. Evaluates **need** for outlet protection based on 2 year culvert outlet velocity and allowable velocity of material in outlet channel or swale
7. Evaluates **type** of outlet protection required based on culvert outlet velocity for design discharge

The objectives of the new details/procedures are to:

1. Minimize impacts to right of way of easement areas at smaller culvert sites
2. Minimize length of stream impacts
3. Minimize need for outlet protection where channel/swale material will be stable for culvert outlet velocities
4. Provide alternative to riprap at sites with low outlet velocities
5. Satisfy DCR Minimum Standard 11

#### **NEW OUTLET PROTECTION DETAILS**

- Dimensions Of Outlet Protection Apron:
  - Type A Installation – Minimum 3H Length & Minimum 3S Width
  - Type B Installation – Minimum 5H Length & Minimum 3S Width
    - Where: S = Span of Culvert  
H = Height of Culvert
    - For a multiple culvert line installations the largest S and H, dimensions of the individual culvert lines should be used in determining the minimum apron length dimensions.
- Outlet Protection Material
  - Class 1 – Standard EC-3 Type B
  - Class 2 – Class AI Dry Riprap
  - Class 3 – Class I Dry Riprap
  - Class 4 – Class II Dry Riprap

#### **NEW OUTLET PROTECTION PROCEDURE**

The following procedure shall be used to analyze the need for outlet protection on:

- All cross drain culverts
- All storm drain outlet pipes
- All entrance and crossover pipes with a diameter of 24” (or equivalent hydraulic opening) or greater

**Step 1** - Determine if Culvert Outlet Protection is required for protection of swale or channel.

- A. Compute culvert outlet velocity for 2 year design storm.
- B. Compare 2 year design storm culvert outlet velocity to allowable velocity for outlet swale/channel material or lining.
  - Swale/channel material type based on field borings/observations or proposed lining.
  - Allowable velocity for natural swale/channel material based on VDOT Drainage Manual Chapter 7 - Appendix 7D-2.

- C. If two year design storm culvert outlet velocity is equal to or less than allowable velocity for swale/channel material, no Culvert Outlet Protection is required for swale/channel protection.
  - **Go to Step 2.**
- D. If two year design storm culvert outlet velocity is greater than allowable velocity for swale/channel material, Culvert Outlet Protection is required.
  - **Go to Step 3.**

**Step 2** - Determine Culvert Outlet Protection required for culvert end protection

- A. Compute culvert outlet velocity for culvert design storm.
- B. If culvert outlet velocity for culvert design storm is less than 6 fps, Culvert Outlet Protection is not required for culvert end protection.
  - **Stop**
- C. If culvert outlet velocity for design storm is 6 fps or greater, Culvert Outlet Protection is required for culvert end protection.
  - **Go to Step 3.**

**Step 3** – Determine Class of Culvert Outlet Protection to use.

- A. When Culvert Outlet Protection is required by either Step 1 or Step 2, the Class of EC-1 to be specified shall be based on the culvert design storm outlet velocity with the following velocity limitations.
  - EC-1 Class 1 – maximum outlet velocity is 6 fps.
  - EC-1 Class 2 – maximum outlet velocity is 8 fps.
  - EC-1 Class 3 – maximum outlet velocity is 14 fps.
  - EC-1 Class 4 – maximum outlet velocity is 19 fps.
  - Use Special Design Culvert Outlet Protection for outlet velocity greater than 19 fps.
- **Go to Step 4**

**Step 4** - Determine Type of EC-1 Installation to use.

- A. When Culvert Outlet Protection is required by either Step 1 or Step 2, specify the Type of Installation to use based on the total hydraulic opening of the culvert installation.
  - Use Type A Installation for culvert installations with a total hydraulic opening of less than 7 square feet.
  - Use Type B Installation for culvert installations with a total hydraulic opening of 7 square feet or greater.

## **PLAN DESCRIPTION**

- \_\_\_\_ Sq. Yds. Standard EC-1 Class \_\_\_\_ Required  
Type \_\_\_\_ Installation

Road and Bridge Standard drawing 114.01 and Road and Bridge Specification Section 414 are being revised to incorporate the new protection measure details outlined in this HDA. (See attached draft standard drawing)

Due to the process for making revisions to the Road and Bridge Standards and Specifications, it may be early fall of this year before the revisions to the standard drawing and specifications are formally published. In the interim, this HDA will serve as authorization to incorporate these changes, as appropriate, into ongoing activities.

DRAFT

EC-1

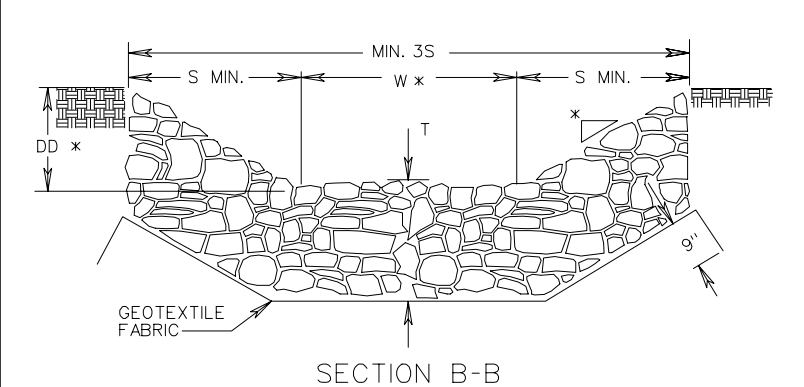
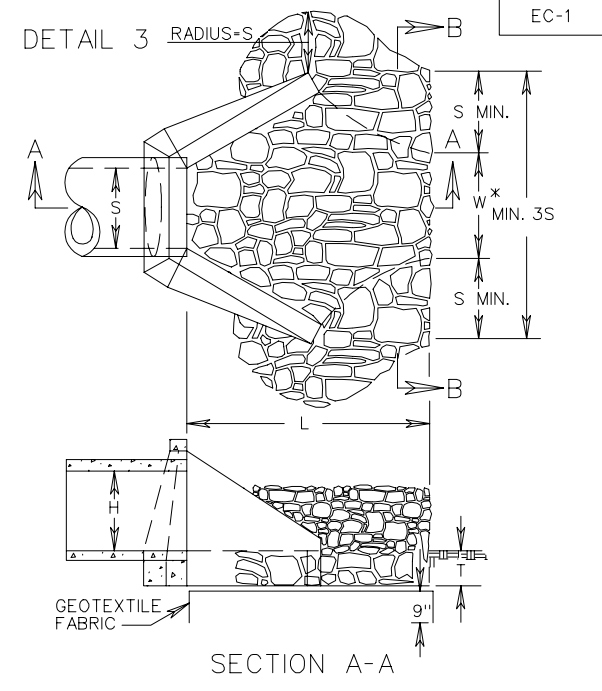
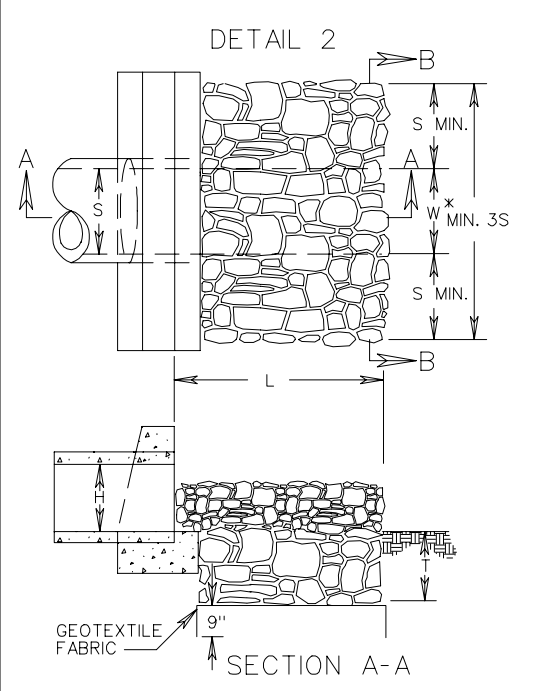
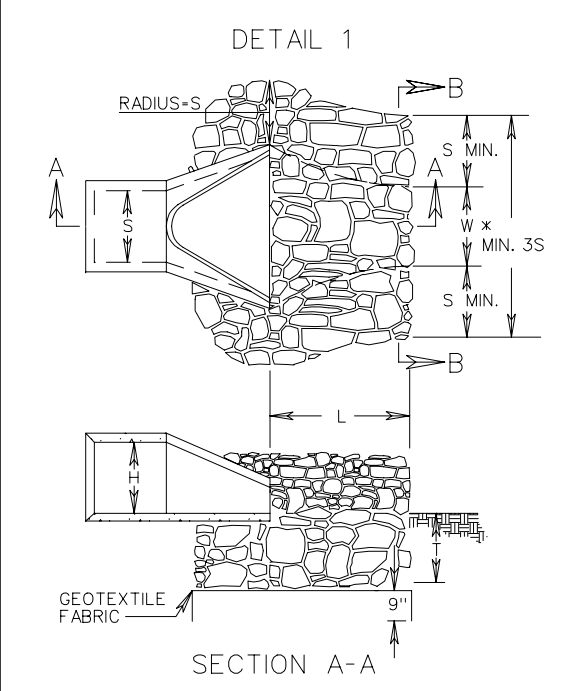

- NOTES:**
- FOR MULTIPLE LINE INSTALLATIONS, DIMENSION S IS TO GOVERN THE PROTECTION OUTSIDE THE CHANNEL WIDTH (W).
  - ON ANY INSTALLATION REQUIRING CULVERT OUTLET PROTECTION WHERE NO ENDWALL OR ENDSECTION IS SPECIFIED ON THE PLANS, CONSTRUCTION IS TO BE IN ACCORDANCE WITH DETAIL 2 SHOWN ABOVE.
  - GEOTEXTILE FABRIC TO BE INSTALLED UNDER CLASS 2, 3, AND 4 MATERIALS IN ACCORDANCE WITH THE SPECIFICATIONS.
  - S = DIAMETER OF CIRCULAR CULVERT OR SPAN FOR BOX, ELLIPTICAL OR ARCH CULVERT. H = DIAMETER OF CIRCULAR CULVERT OR RISE/HEIGHT FOR BOX, ELLIPTICAL OR ARCH CULVERT.
  - PLAN AND SECTION DETAILS DEPICT CLASS 2, 3, AND 4 MATERIALS. FOR CLASS 1 INSTALLATION DETAILS SEE EC-3 TYPE B STANDARD DRAWING.
- \* USE TYPICAL SECTION SHOWN ON PLANS FOR SIDE SLOPE, BOTTOM WIDTH AND DEPTH OF CHANNEL OR MATCH EXISTING DITCH OR NATURAL GROUND.

TYPE OF OUTLET PROTECTION MATERIAL	MAXIMUM OUTLET VELOCITY (FOR DESIGN STORM)	MINIMUM "T"
CLASS 1	EC-3 TYPE B	6 fps
CLASS 2	CLASS A1 DRY RIPRAP	8 fps
CLASS 3	CLASS I DRY RIPRAP	14 fps
CLASS 4	CLASS II DRY RIPRAP	19 fps

OUTLET PROTECTION MINIMUM LENGTH (L)	
TYPE A INSTALLATION	3H
TYPE B INSTALLATION	5H

SPECIFICATION REFERENCE
204
245
303
414

## CULVERT OUTLET PROTECTION

VIRGINIA DEPARTMENT OF TRANSPORTATION

DRAFT

114.01

# HYDRAULIC DESIGN ADVISORY

## HDA 07-01

Date: May 14, 2007

SUBJECT: STORMWATER MANAGEMENT PLANS

AUTHOR: ROY T. MILLS  
STATE HYDRAULICS ENGINEER  
ESC & SWM PROGRAM ADMINISTRATOR

A review of the of the Virginia Stormwater Management Regulations issued July 1, 2006 and a review of VDOT construction projects statewide has identified a need to amend and/or clarify previously issued guidance regarding the application of water quality requirements on VDOT projects.

The Location and Design Division's Instructional and Informational Memorandum IIM-LD-195.5 is amended to replace the first and second bullets under the Water Quality Control section (Sheet 4 and 5 of 14) with the following:

- Regulated Land Disturbance Activities are defined as those activities that disturb one acre or greater except in those areas designated as a Chesapeake Bay Preservation Area in which case the land disturbance threshold is 2,500 square feet or greater.
- "Land Disturbing Activity" or "Land Disturbance" is defined as a manmade change to the land surface that potentially changes its runoff characteristics including any clearing, grading or excavation associated with a construction activity. The effects of a change to the land surface should be based on the proposed permanent condition and should consider the effects of a mature vegetative cover and should not be based on the temporary surface changes during construction activities. The temporary surface changes during construction activities are addressed by the Virginia Erosion and Sediment Control Regulations.
- A water quality control plan for the Regulated Land Disturbance Activity shall be developed for each outfall or watershed unless it meets one of the following exemptions:
  1. Linear development projects (i.e., highway construction projects) where **all** of the following conditions are met:
    - a. Less than one acre will be disturbed per outfall or watershed
    - b. There will be insignificant increases in peak flow rates downstream of the discharge point.
    - c. There is no existing or anticipated flooding or erosion problems downstream of the discharge point.
  2. Routine maintenance activities that are performed to maintain the original line and grade, hydraulic capacity or original construction of the project and that disturbs less than five acres of land.

The Hydraulics Engineer is to add a note to the Stormwater Management Section of the General Notes identifying the following:

1. The applicability of the Virginia Stormwater Management Regulations to the proposed land disturbance activity. If not applicable, state the reason why not.
2. A general description of the stormwater management plan for the land disturbance activity.
3. The location of any specific outfall or watershed where the water quality requirements are not being addressed and the reason why not.
4. Any proposed non-conventional and/or unusual stormwater management practices being used to meet water quality requirements (e.g., Low Impact Development (LID) practices, participation in regional facilities, stream restoration, street sweeping, agreements with others, etc.

The project's hydraulic files are to be thoroughly documented regarding all water quality alternatives considered and reasons for the selected plan.

Instructional and Informational Memoranda IIM-LD-110.18 and 195.5 will be revised in the near future to incorporate these changes as well as others that may be necessary to bring them up to date with current regulatory requirements. In the interim, the guidelines in this HDA should be implemented immediately on all regulated land disturbance activities that have not progressed beyond the right of way stage, where additional right of way would be required to implement these guidelines, or the pre-advertisement stage, where implementation of these guidelines can be accomplished within the identified right of way.