

| STANDARD | TITLE  | PAGE   |
|----------|--|--------|
| PR-2     | PLAIN AND REINFORCED CONCRETE PAVEMENT SHOWING REINFORCEMENT, LONGITUDINAL AND TRANSVERSE JOINTS | 301.01 |
|          | PLAIN AND REINFORCED CONCRETE PAVEMENT SHOWING REINFORCEMENT, LONGITUDINAL AND TRANSVERSE JOINTS | 301.02 |
|          | PLAIN AND REINFORCED CONCRETE PAVEMENT SHOWING REINFORCEMENT, LONGITUDINAL AND TRANSVERSE JOINTS | 301.03 |
|          | STANDARD LOAD TRANSFER ASSEMBLY CONTRACTION JOINT  | 301.04 |
|          | STANDARD LOAD TRANSFER ASSEMBLY EXPANSION JOINT  | 301.05 |
| PR-3     | 8" CONTINUOUSLY REINFORCED CONCRETE PAVEMENT (WIRE MESH REINFORCEMENT)                           | 301.06 |
|          | 8" CONTINUOUSLY REINFORCED CONCRETE PAVEMENT (STEEL BAR REINFORCEMENT)                           | 301.07 |
|          | 8" CONTINUOUSLY REINFORCED CONCRETE PAVEMENT (FOR USE WITH BAR OR WIRE MESH REINFORCEMENT)       | 301.08 |
|          | 8" CONTINUOUSLY REINFORCED CONCRETE PAVEMENT (LEAVE OUT JOINT DETAIL)                            | 301.09 |
| PR-4     | 9" CONTINUOUSLY REINFORCED CONCRETE PAVEMENT (STEEL BAR REINFORCEMENT)                           | 301.10 |
|          | 9" CONTINUOUSLY REINFORCED CONCRETE PAVEMENT (FOR USE WITH BAR REINFORCEMENT ONLY)               | 301.11 |
|          | 9" CONTINUOUSLY REINFORCED CONCRETE PAVEMENT (LEAVE OUT JOINT DETAIL)                            | 301.12 |
| PR-5     | 9" CONTINUOUSLY REINFORCED CONCRETE PAVEMENT 14 FOOT TRAVEL LANE                                 | 301.13 |
|          | 9" CONTINUOUSLY REINFORCED CONCRETE PAVEMENT 14 FOOT TRAVEL LANE                                 | 301.14 |
|          | 9" CONTINUOUSLY REINFORCED CONCRETE PAVEMENT 14 FOOT TRAVEL LANE                                 | 301.15 |
| PR-6     | 10" CONTINUOUSLY REINFORCED CONCRETE PAVEMENT 14 FOOT TRAVEL LANE                                | 301.16 |
|          | 10" CONTINUOUSLY REINFORCED CONCRETE PAVEMENT 14 FOOT TRAVEL LANE                                | 301.17 |
|          | 10" CONTINUOUSLY REINFORCED CONCRETE PAVEMENT 14 FOOT TRAVEL LANE                                | 301.18 |
| PR-7     | 11" CONTINUOUSLY REINFORCED CONCRETE PAVEMENT 14 FOOT TRAVEL LANE                                | 301.19 |
|          | 11" CONTINUOUSLY REINFORCED CONCRETE PAVEMENT 14 FOOT TRAVEL LANE                                | 301.20 |
|          | 11" CONTINUOUSLY REINFORCED CONCRETE PAVEMENT 14 FOOT TRAVEL LANE                                | 301.21 |
| PR-8     | 12" CONTINUOUSLY REINFORCED CONCRETE PAVEMENT 14 FOOT TRAVEL LANE                                | 301.22 |
|          | 12" CONTINUOUSLY REINFORCED CONCRETE PAVEMENT 14 FOOT TRAVEL LANE                                | 301.23 |
|          | 12" CONTINUOUSLY REINFORCED CONCRETE PAVEMENT 14 FOOT TRAVEL LANE                                | 301.24 |
| PR-9     | 13" CONTINUOUSLY REINFORCED CONCRETE PAVEMENT 14 FOOT TRAVEL LANE                                | 301.25 |
|          | 13" CONTINUOUSLY REINFORCED CONCRETE PAVEMENT 14 FOOT TRAVEL LANE                                | 301.26 |
|          | 13" CONTINUOUSLY REINFORCED CONCRETE PAVEMENT 14 FOOT TRAVEL LANE                                | 301.27 |
| XJ-1     | BRIDGE APPROACH EXPANSION JOINT (FOR WIDENING OR MAINTENANCE OR EXISTING XJ-1 ONLY)              | 302.01 |
|          | BRIDGE APPROACH EXPANSION JOINT (INSTALLATION CRITERIA)  | 302.02 |
| WP-1     | METHOD OF WIDENING BRIDGE APPROACH PAVEMENT  | 303.01 |
| WP-2     | PAVEMENT WIDENING  | 303.02 |
| RS-1     | CONTINUOUS SHOULDER RUMBLE STRIPS  | 304.01 |
| RS-2     | CENTERLINE RUMBLE STRIPS   | 304.02 |
| TPT-1    | TRANSVERSE PAVEMENT TIE-IN   | 305.01 |

INDEX OF SHEETS  
SECTION 300-PAVEMENT ITEMS

VIRGINIA DEPARTMENT OF TRANSPORTATION



ROAD AND BRIDGE STANDARDS

|               |              |
|---------------|--------------|
| REVISION DATE | SHEET 1 OF 1 |
|---------------|--------------|

300.01

THIS PAGE INTENTIONALLY LEFT BLANK



ROAD AND BRIDGE STANDARDS

SHEET 1 OF 1

REVISION DATE

300.02

VIRGINIA DEPARTMENT OF TRANSPORTATION

SPECIFICATION  
REFERENCE

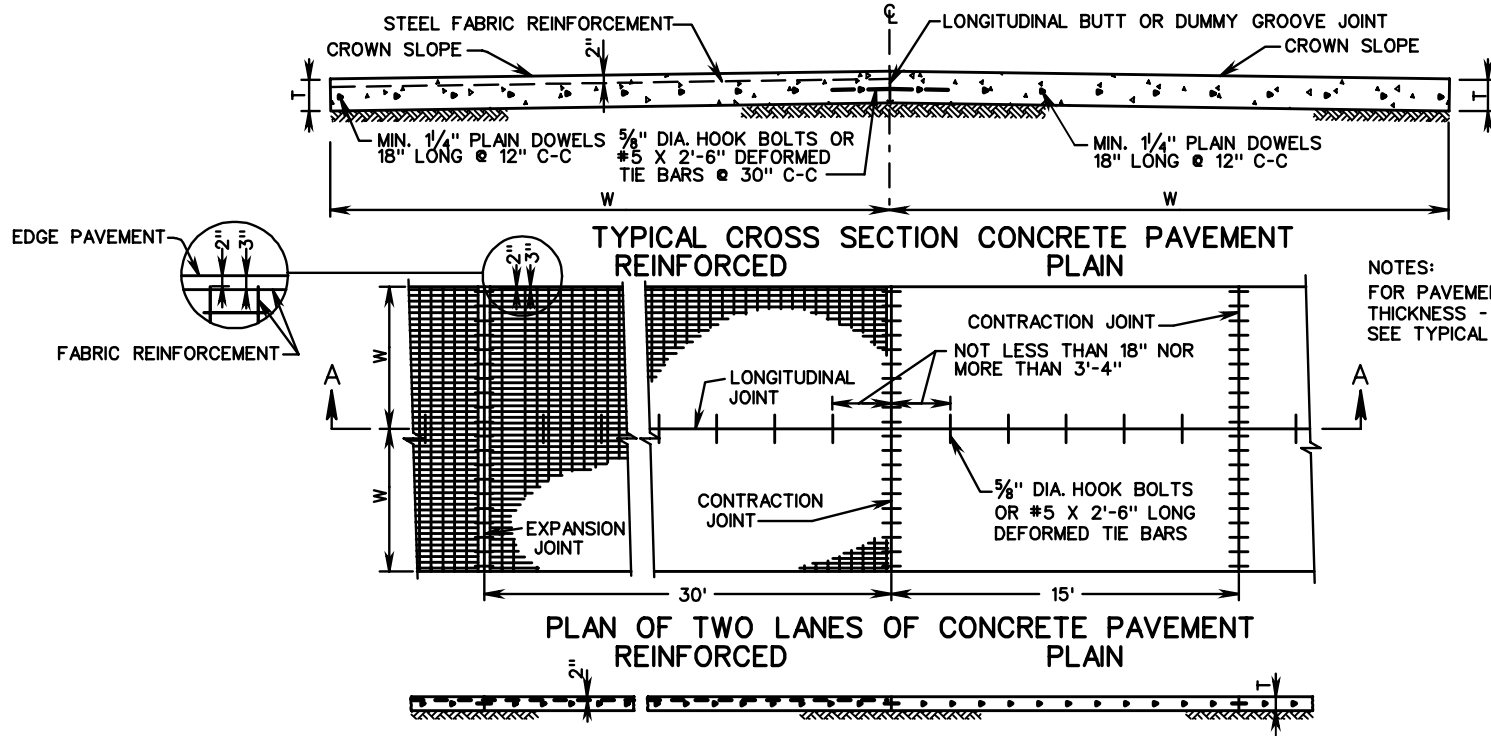

NOTES:  
FOR PAVEMENT CROWN SLOPE,  
THICKNESS - "T", LANE WIDTH - "W",  
SEE TYPICAL SECTIONS IN PLANS.

**STEEL FABRIC REINFORCEMENT:** STEEL FABRIC REINFORCEMENT SHALL CONSIST OF MEMBERS RIGIDLY ATTACHED AT ALL JOINTS OR POINTS OF INTERSECTION EXCEPT AS NOTED BELOW:(\*). LONGITUDINAL MEMBERS SHALL BE OF NO. 2 GAGE WIRE SPACED AT 6" ON CENTERS. TRAVERSE MEMBERS SHALL BE NO. 4 GAGE WIRE, SPACED AT 12" ON CENTERS. (WIRE REINFORCEMENT STEEL INSTITUTE DESIGNATION 6 X 12 - W5.5 X W4).

THE WIDTHS OF STEEL FABRIC SHEETS SHALL BE 4" LESS THAN THE WIDTH OF THE SLAB. THE NUMBER OF SHEETS ALLOWABLE BETWEEN CONTRACTION JOINTS, OR BETWEEN CONTRACTION AND EXPANSION JOINTS, SHALL NOT EXCEED 3.

ALL MEMBERS, LONGITUDINAL OR TRANSVERSE, SHALL BE SO CUT THAT THE PROJECTING ENDS WILL EXTEND NOT LESS THAN 1" NOR MORE THAN 11" FROM THE JOINTS OR POINTS OF INTERSECTION OF THE FABRIC MEMBERS.

WHEN IT IS NECESSARY TO LAP STEEL FABRIC REINFORCEMENT, THE MINIMUM AMOUNT OF LAP SHALL BE EQUIVALENT TO THE SPACING OF THE WIRES PARALLEL TO THE LAP.

OTHER TYPES OF MESH REINFORCEMENT MAY BE USED ON WRITTEN PERMISSION OF THE ENGINEER. THE WIDTH OF SHEETS AND OTHER GENERAL REQUIREMENTS, WHICH APPLY, SHALL BE THE SAME AS FOR STEEL FABRIC REINFORCEMENT.

DOWELS AT CONTRACTION JOINTS MAY BE PLACED IN THE FULL THICKNESS OF PAVEMENT BY MECHANICAL DEVICE IN LIEU OF DOWEL BASKETS.

\* HINGED STEEL REINFORCEMENT MAY BE USED IN LIEU OF RIGID SHEETS.

**EXPANSION AND CONTRACTION JOINTS:** CONSTRUCTION JOINTS IN BOTH PLAIN AND REINFORCED PAVEMENT SHALL HAVE THE SAME LOAD TRANSFER DEVICES AS NOTED FOR CONTRACTION JOINTS IN REINFORCED PAVEMENT.

CONTRACTION JOINTS OF THE TYPE SPECIFIED ON SHEET 2 SHALL BE SPACED AT 30 FOOT INTERVALS FOR REINFORCED CONCRETE PAVEMENT AND AT 15 FOOT INTERVALS FOR PLAIN CONCRETE PAVEMENT UNLESS OTHERWISE NOTED ON JOINT LAYOUTS IN PLANS.

ADJACENT TO RIGID STRUCTURES: CONCRETE STREET INTERSECTIONS, OR R.R. GRADE X-INGS, BRIDGE APPROACH EXPANSION JOINTS AND/OR TRANSVERSE EXPANSION JOINTS ARE TO BE PLACED AS SHOWN ON SHEET 2 OF 3. OTHER EXPANSION JOINTS ARE TO BE USED AS SPECIFIED ON PLANS.

IF ASPHALT CONCRETE IS TO BE APPLIED, ALL TRANSVERSE JOINTS ARE TO BE SAWED, BUT NOT WIDENED, EXCEPT AT THE END OF A DAYS RUN AND WHEN INTERRUPTIONS OCCUR IN THE CONCRETE OPERATIONS OF MORE THAN 30 MINUTES DURATION. IN THESE CASES, BUTT CONSTRUCTION JOINTS ARE TO BE USED.

PAVED SHOULDERS: WHEN ASPHALT CONCRETE PAVED SHOULDERS ARE TO BE USED ADJACENT TO EITHER PLAIN OR REINFORCED CEMENT CONCRETE PAVEMENT, THE EDGE OF THE CONCRETE SLAB IS TO BE PAINTED, TO ITS FULL DEPTH, WITH ASPHALTIC MATERIAL EITHER CRS-2 OR RC-250 AS DIRECTED BY THE ENGINEER.

**LONGITUDINAL JOINTS:** THE CONTRACTOR WILL BE PERMITTED TO CONSTRUCT THE CONCRETE PAVEMENT IN DUAL LANES, SIMULTANEOUSLY, WHERE THE SUM OF THE LANE WIDTHS DOES NOT EXCEED 25 FEET, PROVIDED A SATISFACTORY AND TRUE LONGITUDINAL DUMMY GROOVE JOINT IS OBTAINED. THIS IS TO BE DONE BY THE USE OF AN APPROVED FORMING STRIP OR BY SAWING, AT THE CONTRACTOR'S OPTION. WHERE LANES ARE POURED SEPARATELY, THE HOOK BOLTS OR TIE BOLTS SHALL BE IN ACCORDANCE WITH THE DETAILS SHOWN OF SHEET 2. WHERE BOTH LANES ARE POURED SIMULTANEOUSLY, TIE BARS SHALL BE AS DETAILED ON SHEET 2. THE MAXIMUM WIDTH OF PAVEMENT THAT MAY BE CONSTRUCTED WITHOUT A LONGITUDINAL JOINT IS 14'-0". FOR WIDTHS GREATER THAN 14 FEET THE LONGITUDINAL JOINT SHALL BE IN THE CENTER. NO OTHER DEVIATIONS ARE TO BE ALLOWED UNLESS SHOWN ON JOINT LAYOUT IN PLANS, OR DIRECTED BY THE ENGINEER.

**METHOD OF FINISHING AT EXPANSION JOINTS:** A PROTECTIVE CAP OR INSTALLATION SHIELD OF 1/16" STEEL SHALL BE PLACED OVER THE TOP OF THE EXPANSION JOINT FILLER. THE FINISHING MACHINE SHALL THEN BE ALLOWED TO PASS OVER THE JOINT, LEAVING IT AS SHOWN IN FIGURE 1, SHEET 2. PRIOR TO THE INITIAL SET THE SHIELD SHALL BE REMOVED AND A RECTANGULAR BAR 1/4" LESS IN WIDTH THAN THE PREFORMED FILLER PLACED ON TOP OF THE FILLER, THE CONCRETE SQUEEGE FINISHED ADJACENT TO IT AS SHOWN IN FIGURE 2, AND THE EDGES ROUNDED WITH HAND TOOLS, USING THE BAR AS A GUIDE. THE BAR SHALL THEN BE WITHDRAWN, LEAVING A JOINT GAP OF THE SAME WIDTH AS THE FILLER.

SPECIFICATION REFERENCE

316

# PLAIN AND REINFORCED CONCRETE PAVEMENT (SHOWING REINFORCEMENT, LONGITUDINAL AND TRANSVERSE JOINTS)

VIRGINIA DEPARTMENT OF TRANSPORTATION

VDOT

ROAD AND BRIDGE STANDARDS

REVISION DATE

SHEET 1 OF 5

301.01

PR-2

FOR X AND Y DIM. SEE  
ST'D. PR-2 SHEET 3 OF 5

⊗ JT. SEALANTS TO BE IN  
ACCORDANCE WITH  
DETAILS ON ST'D. PR-2  
SHEET 3 OF 5

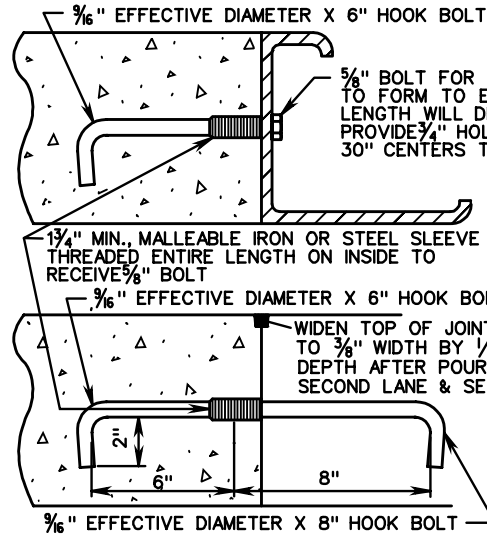
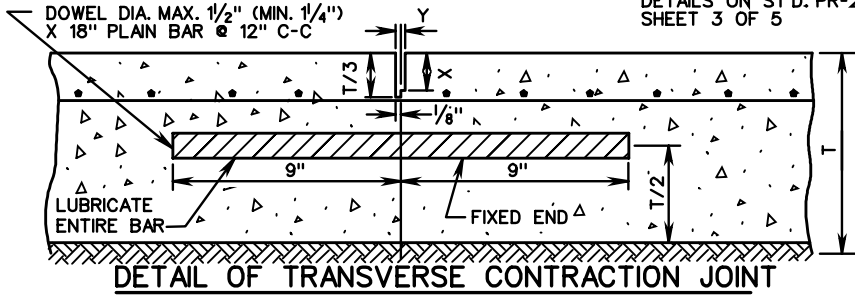

NOTE:  
3/16" EFFECTIVE DIAMETER HOOK BOLTS TO BE 3/16" DIAMETER STOCK FOR ROLLED THREADS AND 5/8" DIAMETER STOCK FOR CUT THREADS O.D. OF THREADED PORTION TO BE 5/8".  
ANY SIMILAR DEVICE OF EQUAL STRENGTH WILL BE ACCEPTED IF APPROVED BY THE ENGINEER.

NOTE:  
#5 X 2'-6" DEFORMED TIE BARS AT 30" C-C MAY BE USED IN LIEU OF HOOK BOLTS.

⊗ SEAL WITH AN APPROVED JOINT SEALANT. A BAND BREAKING MATERIAL IS TO BE PROVIDED BETWEEN THE JOINT FILLER AND SEAL.

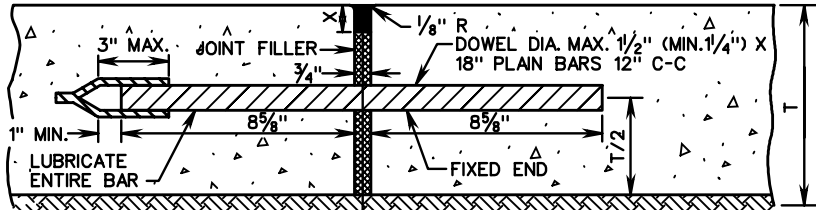

DETAIL OF TRANSVERSE EXPANSION JOINT  
FOR X AND Y DIMENSIONS SEE STANDARD PR-2 SHEET 3 OF 5.

DETAIL OF LONGITUDINAL JOINT HOOK BOLTS  
SHOWING PAVEMENT POURED IN SINGLE LANES

WIDEN TOP OF GROOVE TO 3/8" WIDTH BY 1/2" DEPTH & SEAL IF ASPHALT TOP NOT USED.

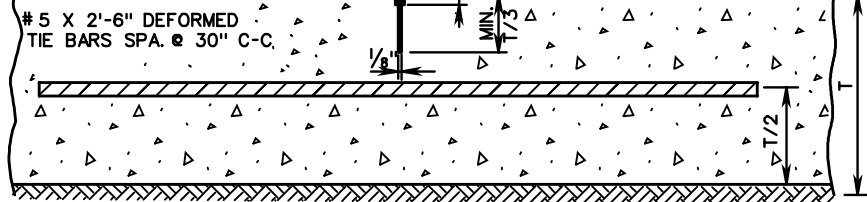

GRADE 40 TIE BARS MAY BE PRE-BENT AND STRAIGHTENED ONE TIME ONLY FOR MULTI-LANE CONSTRUCTION IN ACCORDANCE WITH SPECIFICATIONS.

DETAIL OF LONGITUDINAL JOINT TIE BARS  
SHOWING ADJACENT LANES POURED SIMULTANEOUSLY

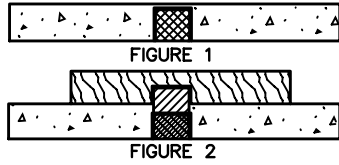

SMOOTH SURFACE TO BE STEEL TROWELED 8" IN FROM THE EDGE OF PAVEMENT EVERY 500', AND STATION NUMBER STAMPED INTO IT. THE DATE IS TO BE SHOWN IN A SIMILAR MANNER AT THE BEGINNING OF EACH DAY'S POUR.

METHOD OF FINISHING AT EXPANSION JOINTS

BOTH OUTSIDE EDGES OF DIVIDED HIGHWAY TO BE STAMPED. ONE EDGE OF UNDIVIDED HIGHWAYS WHERE FEASIBLE.

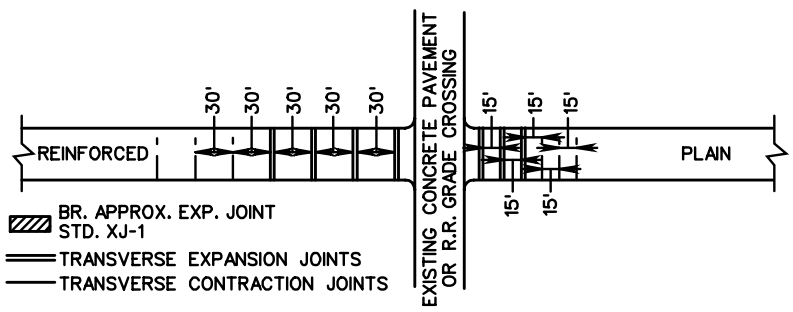
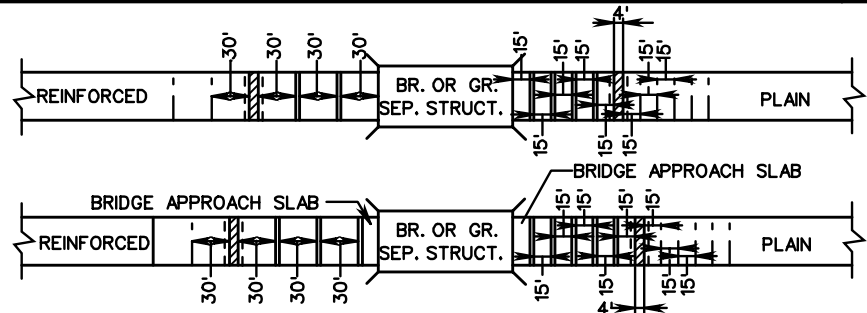

DETAILS OF JOINTS LAYOUTS  
(FOR USE WHEN COVERED ON JOINT LAYOUTS IN PLANS)



ROAD AND BRIDGE STANDARDS

PLAIN AND REINFORCED CONCRETE PAVEMENT  
(SHOWING REINFORCEMENT, LONGITUDINAL AND TRANSVERSE JOINTS)

SPECIFICATION REFERENCE

SHEET 2 OF 5

REVISION DATE

VIRGINIA DEPARTMENT OF TRANSPORTATION

316

301.02

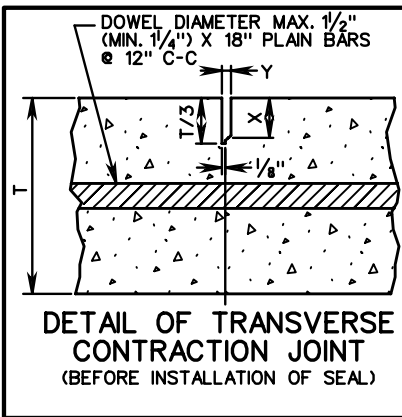

**DETAIL OF TRANSVERSE CONTRACTION JOINT**  
(BEFORE INSTALLATION OF SEAL)

**GENERAL NOTES**

ALTERNATE PREFORMED SEALANTS HAVING A CROSS-SECTIONAL AREA COMPARABLE TO TYPE A (CONTRACTION JOINTS) AND TYPE D (EXPANSION JOINTS) AND MEETING THE APPROVAL OF THE ENGINEER MAY BE SUBSTITUTED.

OTHER TYPES OF JOINT MATERIAL ARE TO BE IN ACCORDANCE WITH THE SPECIFICATIONS.

ALL DETAILS NOT SHOWN HEREON TO BE IN ACCORDANCE WITH STANDARDS PR-2, SHEET 2 OF 5.

ALL CONTRACTION JOINTS TO BE SAWED IN CONFORMANCE WITH DETAIL TO THE LEFT, EXCEPT THAT WHERE GRAVEL AGGREGATE IS USED IN THE CONCRETE, THE JOINT MAY BE PREPARED BY FORMING 1/4" OR LESS OF THE WIDTH, FOR THE DEPTH SHOWN WITH NON-METALLIC OR REMOVABLE MATERIAL, FOLLOWED BY SAWING TO COMPLETE THE JOINT TO THE REQUIRED WIDTH AND DEPTH.

FOR DETAILS OF TRANSVERSE CONSTRUCTION JOINT, SEE BELOW.

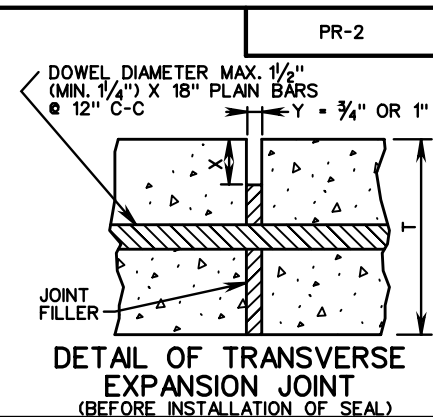

**DETAIL OF TRANSVERSE EXPANSION JOINT**  
(BEFORE INSTALLATION OF SEAL)

**PREFORMED CHLOROPRENE ELASTOMERIC JOINT SEALANT**

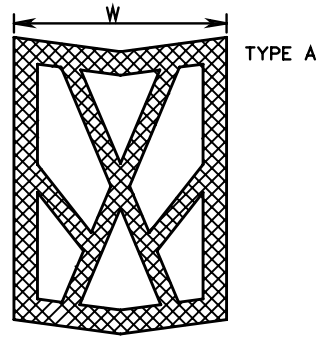

**SEALANTS FOR TRANSVERSE CONTRACTION JOINTS**

**SILICONE JOINT SEALANT**

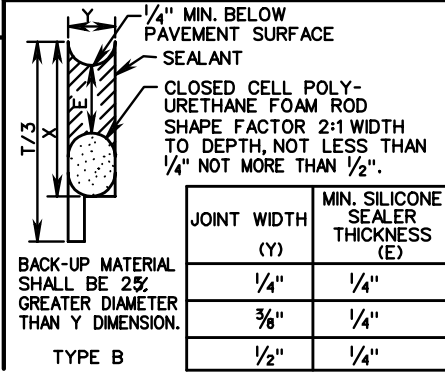

BACK-UP MATERIAL SHALL BE 25% GREATER DIAMETER THAN Y DIMENSION.

| JOINT WIDTH (Y) | MIN. SILICONE SEALER THICKNESS (E) |
|-----------------|------------------------------------|
| 1/4"            | 1/4"                               |
| 3/8"            | 1/4"                               |
| 1/2"            | 1/4"                               |

**SILICONE JOINT SEALANT**

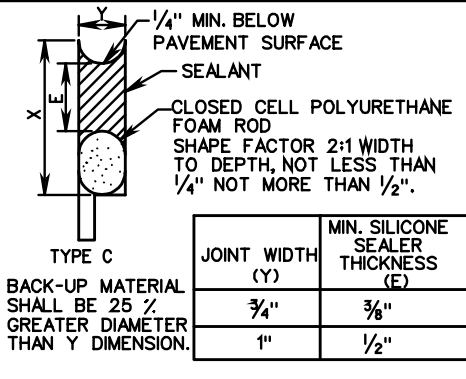

BACK-UP MATERIAL SHALL BE 25% GREATER DIAMETER THAN Y DIMENSION.

| JOINT WIDTH (Y) | MIN. SILICONE SEALER THICKNESS (E) |
|-----------------|------------------------------------|
| 3/4"            | 3/8"                               |
| 1"              | 1/2"                               |

**SEALANTS FOR TRANSVERSE EXPANSION JOINTS**

**PREFORMED CHLOROPRENE ELASTOMERIC JOINT SEALANT**

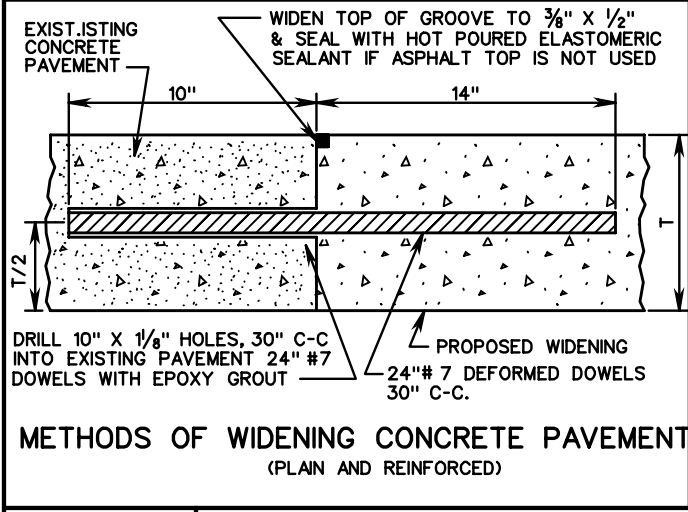
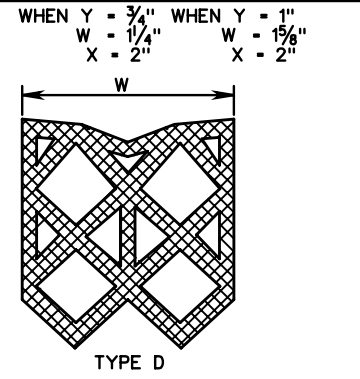

**METHODS OF WIDENING CONCRETE PAVEMENT**  
(PLAIN AND REINFORCED)

| DIMENSION | SEALANT TYPE |      |             |            |
|-----------|--------------|------|-------------|------------|
|           | A            | B    | C           | D          |
| X         | 1 3/4"       | 1/4" | 1 3/4" - 2" | 2"         |
| Y         | 1/4"         | 1/4" | 3/4" OR 1"  | 3/4" OR 1" |
| W         | 5/8" ± 1/16" | -    | -           | -          |

| DIMENSION | SEALANT TYPE |      |              |            |
|-----------|--------------|------|--------------|------------|
|           | A            | B    | C            | D          |
| X         | 1 3/4"       | 1/4" | 1 3/4" OR 2" | 2"         |
| Y         | 3/8"         | 3/8" | 3/4" OR 1"   | 3/4" OR 1" |
| W         | 1/4" ± 1/16" | -    | -            | -          |

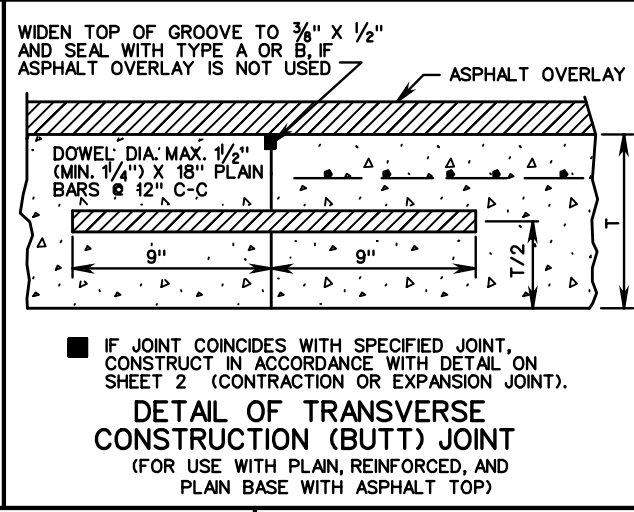

|                         |
|-------------------------|
| SPECIFICATION REFERENCE |
| 316                     |

**PLAIN AND REINFORCED CONCRETE PAVEMENT**  
SHOWING REINFORCEMENT, LONGITUDINAL AND TRANSVERSE JOINTS

VIRGINIA DEPARTMENT OF TRANSPORTATION

|                           |              |
|---------------------------|--------------|
| <b>VDOT</b>               |              |
| ROAD AND BRIDGE STANDARDS |              |
| REVISION DATE             | SHEET 3 OF 5 |
| 301.03                    |              |

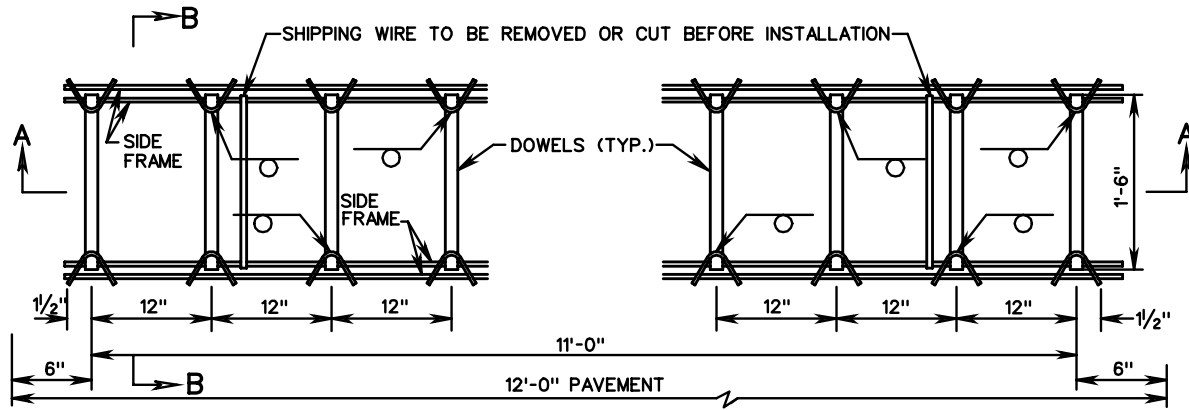

PLAN OF DOWEL UNIT FOR CONTRACTION JOINT

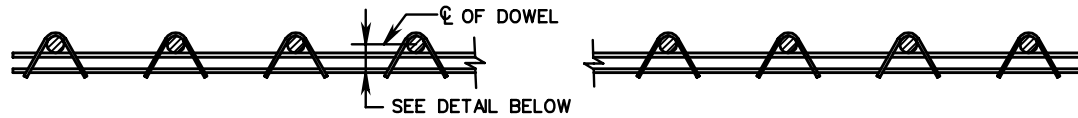

SIDE ELEVATION A - A CONTRACTION JOINT

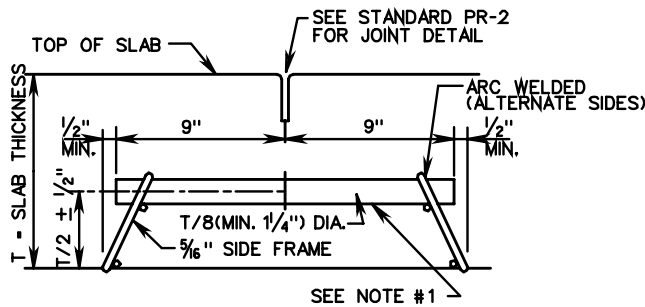

SECTION B - B  
THRU CONTRACTION JOINT

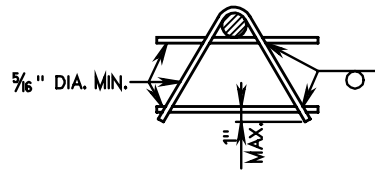

SIDE FRAME DETAIL

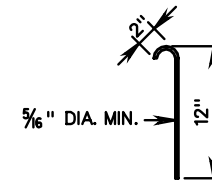

STAKING PIN

NOTES:

1. ENTIRE BAR TO BE LUBRICATED.
2. STAKING PINS, A MINIMUM SIX PER ASSEMBLY, THREE TO EACH SIDE.
3. EXPANSION AND CONTRACTION JOINTS: THE DEVICE FOR SUPPORTING DOWELS AT EXPANSION AND CONTRACTION JOINTS SHALL BE SO CONSTRUCTED THAT IT WILL HOLD THE DOWELS FIRMLY IN POSITION, PARALLEL TO THE SURFACE AND CENTERLINE OF THE SLAB.
4. NO MEMBERS SHALL BE PLACED SO THAT THEY WILL INTERFERE WITH THE FREE FLOW OF CONCRETE BETWEEN THE DOWELS.
5. ASSEMBLY AND WELDING OF ALL MEMBERS SHALL BE SUCH AS TO INSURE A GOOD WORKMANLIKE JOB, WITH ALL JOINTS TRUE AND SQUARE.
6. ASSEMBLIES WHICH HAVE BECOME WARPED OR DAMAGED IN TRANSIT OR STORAGE SO THEY WILL NOT CONFORM TO THE SUBGRADE SHALL NOT BE USED.
7. A SAMPLE OF THE SUPPORTING DEVICE SHALL BE SUBMITTED FOR APPROVAL PRIOR TO THE FILLING OF JOB ORDERS.

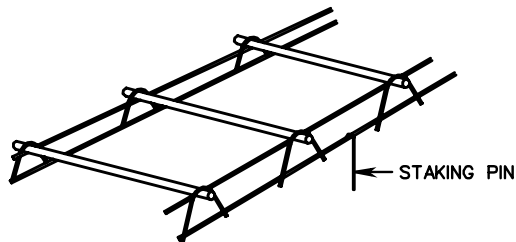

PERSPECTIVE VIEW



ROAD AND BRIDGE STANDARDS

SHEET 4 OF 5

REVISION DATE

301.04

STANDARD LOAD TRANSFER ASSEMBLY  
CONTRACTION JOINT

VIRGINIA DEPARTMENT OF TRANSPORTATION

SPECIFICATION  
REFERENCE

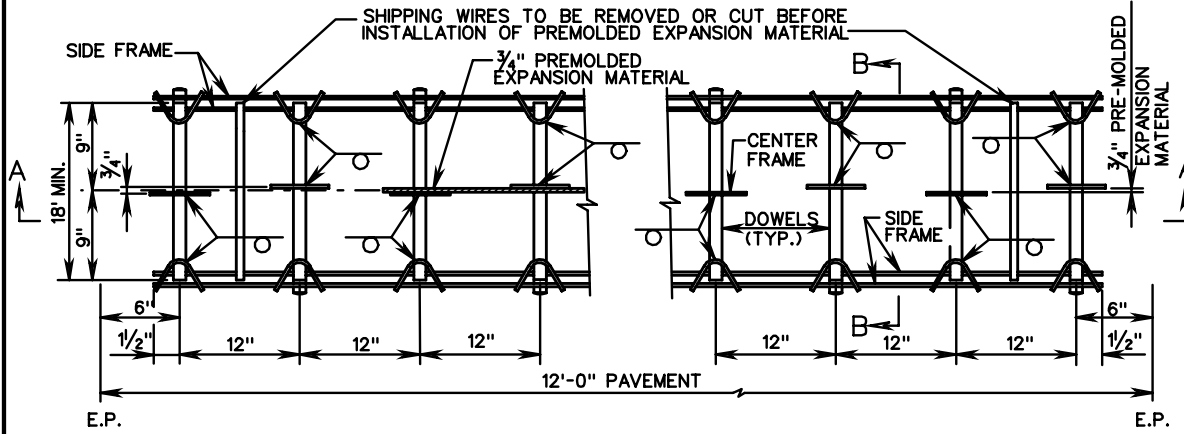

PLAN OF EXPANSION LIMIT

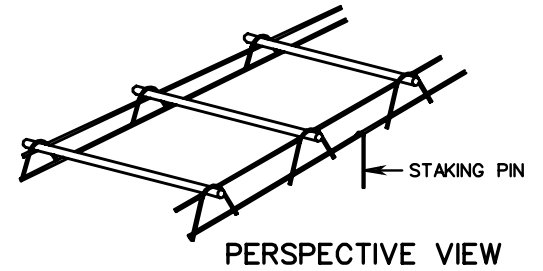

PERSPECTIVE VIEW

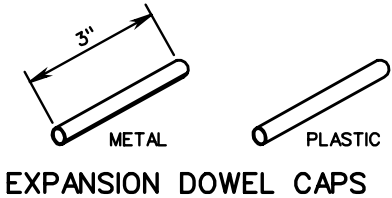

EXPANSION DOWEL CAPS

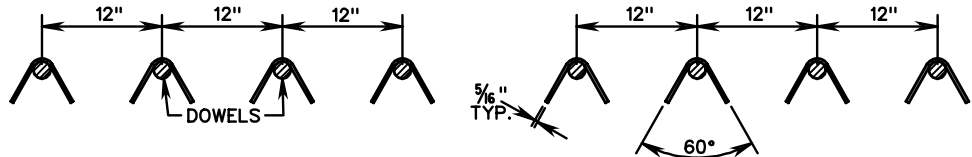

SECTION A - A CENTER FRAME

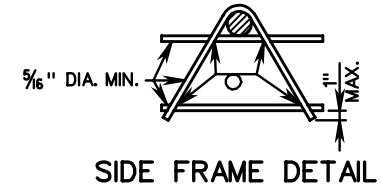

SIDE FRAME DETAIL

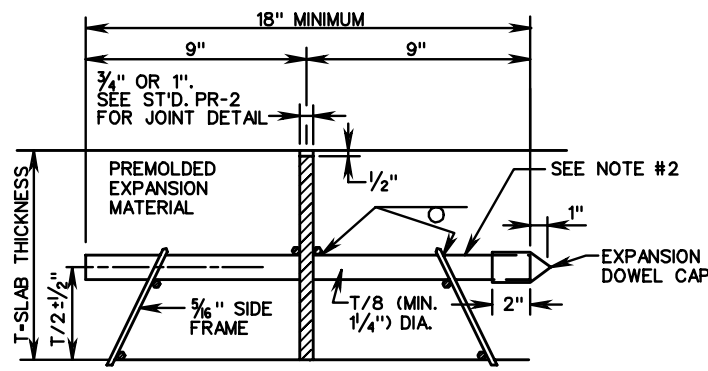

SECTION B - B THRU EXPANSION JOINT

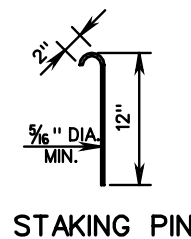

STAKING PIN

NOTES:

1. DOWEL BAR TO BE MIN. LENGTH OF 18". IF BAR IS NOT CENTERED THE LONG SIDE SHALL BE THE FREE END. SEE STANDARD PR-2.
2. ENTIRE BAR TO BE LUBRICATED.
3. STAKING PINS, A MINIMUM SIX PER ASSEMBLY, THREE TO EACH SIDE.
4. EXPANSION AND CONTRACTION JOINTS: THE DEVICE FOR SUPPORTING DOWELS AT EXPANSION AND CONTRACTION JOINTS SHALL BE SO CONSTRUCTED THAT IT WILL HOLD THE DOWELS FIRMLY IN POSITION, PARALLEL TO THE SURFACE AND CENTER-LINE OF THE SLAB.
5. NO MEMBERS SHALL BE PLACED SO THAT THEY WILL INTERFERE WITH THE FREE FLOW OF CONCRETE BETWEEN DOWELS.
6. ASSEMBLY AND WELDING OF ALL MEMBERS SHALL BE SUCH AS TO INSURE A GOOD WORKMANLIKE JOB, WITH ALL JOINTS TRUE AND SQUARE.
7. ASSEMBLIES WHICH HAVE BECOME WARPED OR DAMAGED IN TRANSIT OR STORAGE SO THEY WILL NOT CONFORM TO THE SUBGRADE SHALL NOT BE USED.
8. A SAMPLE OF THE SUPPORTING DEVICE SHALL BE SUBMITTED FOR APPROVAL PRIOR TO THE FILLING OF JOB ORDERS.

SPECIFICATION REFERENCE

# STANDARD LOAD TRANSFER ASSEMBLY EXPANSION JOINT

VIRGINIA DEPARTMENT OF TRANSPORTATION

VDOT

ROAD AND BRIDGE STANDARDS

REVISION DATE

SHEET 5 OF 5

301.05

PR-3

TRANSVERSE CONSTR. JOINT

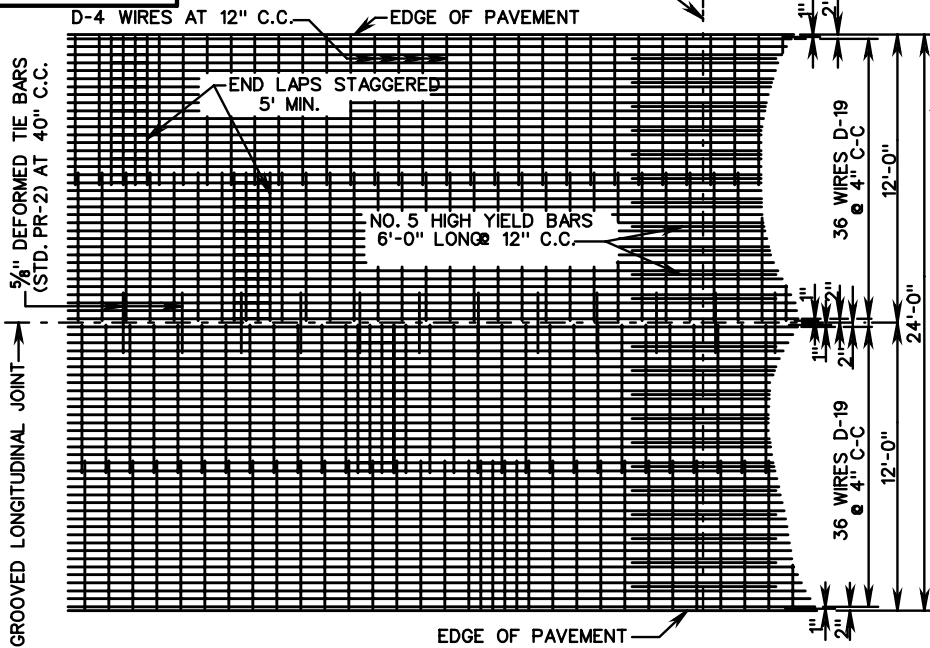

PLAN VIEW

NOTES:

- FOR 36' PAVEMENT, USE SINGLE 12' LANES WITH 2 CONSTRUCTION JOINTS, OR 12' AND 24' LANES WITH ONE GROOVE AND ONE CONSTRUCTION JOINT.
- TRANSVERSE WIRES DO NOT EXTEND THROUGH LONGITUDINAL JOINTS.
- TIE BARS AND DOWEL BARS ARE TO BE AS NEAR MIDPOINT OF PAVEMENT DEPTH AS FEASIBLE.
- \*THE DOUBLE LAP REQUIREMENT (36") AND OR EXTRA BAR METHOD APPLIES ONLY TO LAPS FALLING WITHIN AAN AREA 10' BEYOND THE CONSTRUCTION JOINT.
- #5 X 2'-6" DEFORMED TIE BARS AT 30" O.C. MAY BE USED IN LIEU OF HOOK BOLTS WHERE SHOWN HEREON.

SMOOTH SURFACE TO BE STEEL TROWELED 8" IN FROM THE EDGE OF PAVEMENT EVERY 500 FEET, AND STATION NUMBER STAMPED INTO IT. THE DATE IS TO BE SHOWN IN A SIMILAR MANNER AT THE BEGINNING OF EACH DAYS POUR.

BOTH OUTSIDE EDGES OF DIVIDED HIGHWAY TO BE STAMPED. ONE EDGE OF UNDIVIDED HIGHWAYS WHERE FEASIBLE. (TRAVEL LANE)

SHEETS TO BE SECURELY FASTENED TO PREVENT SEPARATION DURING CONCRETE PLACEMENT.

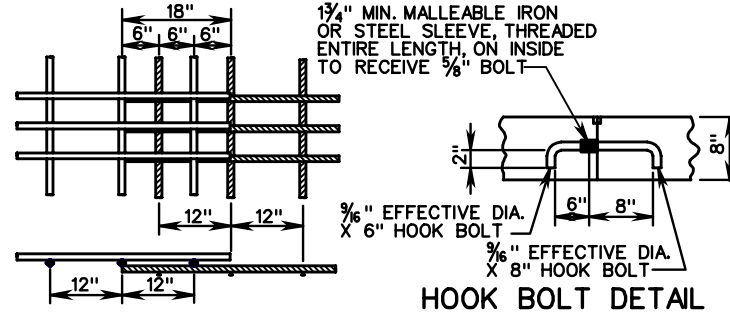

HOOK BOLT DETAIL

HOOK BOLTS AT 30" C.C. TO BE USED WHEN PAVEMENT IS POURED IN SINGLE LANES.

END LAP DETAIL

D-19 WIRES @ 4" C.C.

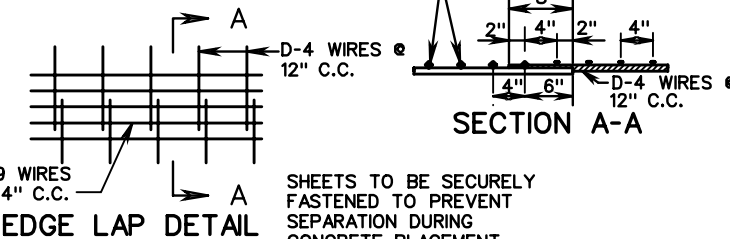

EDGE LAP DETAIL

SHEETS TO BE SECURELY FASTENED TO PREVENT SEPARATION DURING CONCRETE PLACEMENT,

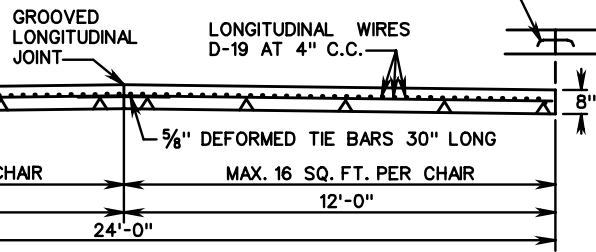

TRANSVERSE SECTION

NO LAP WITHIN 3' BACK OF CONST. JOINT

NO LAP WITHIN 8' AHEAD OF CONST. JOINT

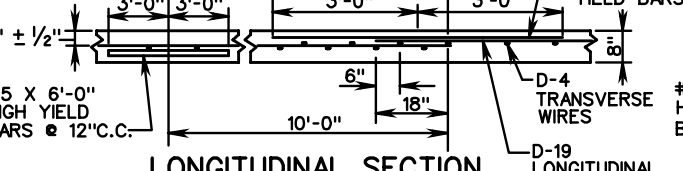

LONGITUDINAL SECTION EXTRA BAR METHOD

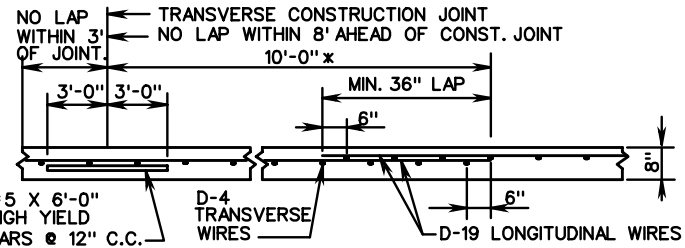

LONGITUDINAL SECTION DOUBLE LAP METHOD

8" THICK CONTINUOUSLY REINFORCED CONC. PAVE.

(WIRE MESH REINFORCEMENT)

SPECIFICATION REFERENCE

316



ROAD AND BRIDGE STANDARDS

SHEET 1 OF 4

REVISION DATE

301.06

VIRGINIA DEPARTMENT OF TRANSPORTATION



NOTES: HOOK BOLTS OR TIE BARS ARE TO BE PLACED IN THE SAME HORIZONTAL PLANE AS # 4 TRANSVERSE BARS. WHERE NECESSARY ADJUST THE LOCATION OF HOOK BOLTS OR TIE BARS TO A 2 1/2" MINIMUM CLEARANCE BETWEEN HOOK BOLTS OR TIE BARS AND TRANSVERSE BARS.

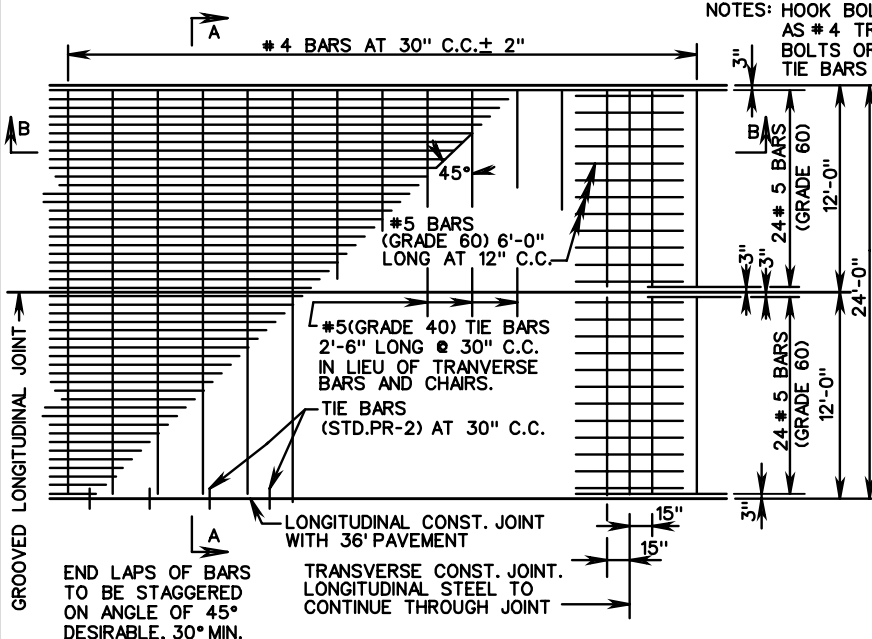

TRANSVERSE CONSTRUCTION JOINT BARS ARE TO BE PLACED IN THE SAME HORIZONTAL AS # 5 LONGITUDINAL BARS.  
 #5 LONGITUDINAL BARS ARE TO BE LAPPED AND TIED IN THE SAME HORIZONTAL PLANE.  
 FOR 36' WIDTH PAVEMENT USE SINGLE 12' LANES WITH 2 LONGITUDINAL CONSTRUCTION JOINTS OR 12' AND 24' LANES WITH ONE LONGITUDINAL CONSTRUCTION JOINT AND ONE GROVED LONGITUDINAL JOINT. TRANSVERSE BARS SHALL NOT EXTEND THROUGH LONGITUDINAL CONSTRUCTION JOINTS, BUT SHALL EXTEND FULL LENGTH (23'-9") FOR GROOVED LONGITUDINAL JOINTS.

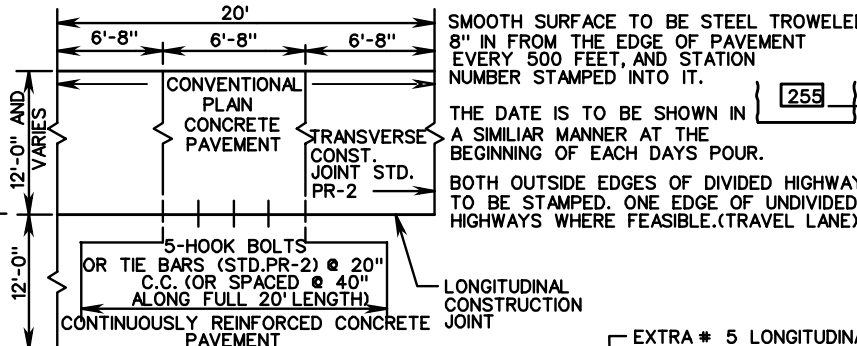

SMOOTH SURFACE TO BE STEEL TROWELED 8" IN FROM THE EDGE OF PAVEMENT EVERY 500 FEET, AND STATION NUMBER STAMPED INTO IT.  
 THE DATE IS TO BE SHOWN IN A SIMILAR MANNER AT THE BEGINNING OF EACH DAYS POUR.  
 BOTH OUTSIDE EDGES OF DIVIDED HIGHWAY TO BE STAMPED. ONE EDGE OF UNDIVIDED HIGHWAYS WHERE FEASIBLE. (TRAVEL LANE)

PLAN-RAMP & MAIN LINE CONNECTION

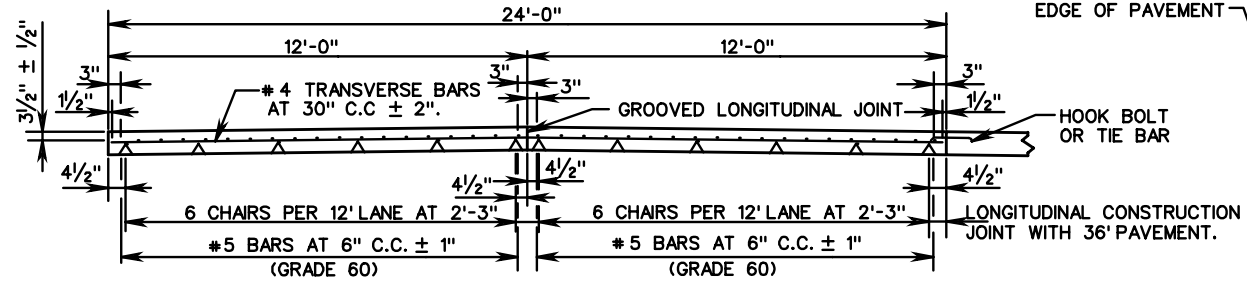

SECTION A-A

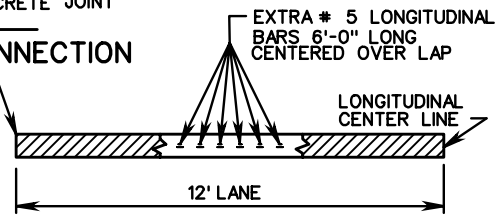

SECTION C-C

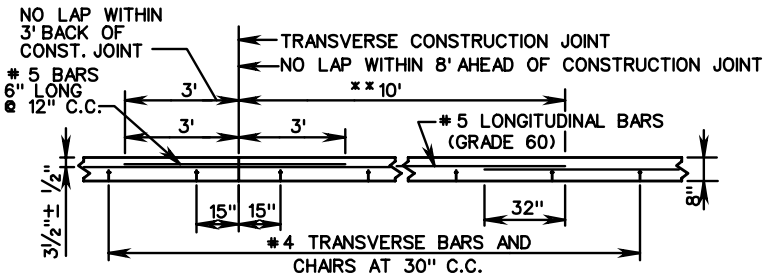

SECTION B-B  
DOUBLE LAP METHOD

\*\* DOUBLE LAP REQUIREMENT (32") AND THE EXTRA BAR METHOD APPLY ONLY TO LAPS FALLING WITHIN AN AREA OF 10' BEYOND THE CONSTRUCTION JOINT.

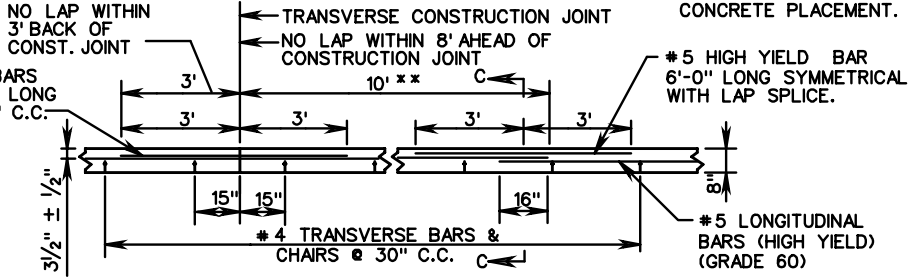

SECTION B-B  
EXTRA BAR METHOD

SPECIFICATION REFERENCE

8" THICK CONTINUOUSLY REINFORCED CONC. PAVE.

(STEEL BAR REINFORCEMENT)

316

VIRGINIA DEPARTMENT OF TRANSPORTATION



ROAD AND BRIDGE STANDARDS

REVISION DATE SHEET 2 OF 4

301.07

PR-3

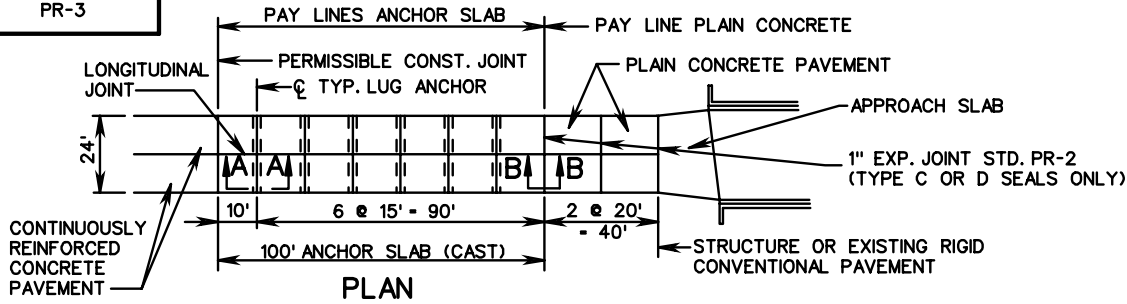

**NOTES:**

CONCRETE FOR LUG ANCHORS SHALL BE POURED AGAINST COMPACTED SUBGRADE. CONCRETE FOR LUGS AND ANCHOR SLAB MAY BE POURED MONOLITHICALLY OR POURED USING RAISED KEY CONSTRUCTION JOINT METHOD.

ADEQUATE CONSOLIDATION OF CONCRETE IN LUGS WILL BE OBTAINED WITHOUT DISPLACING LONGITUDINAL CONTINUOUS STEEL, BY THE USE OF INTERNAL VIBRATION.

WHEN LESS THAN FULL WIDTH LUG AND PAVEMENT SLAB IS PLACED, THE # 5 TRANSVERSE STEEL IN THE LUGS SHALL BE EXTENDED, LAPPED AND SPLICED IN AT LEAST 25 DIAMETERS.

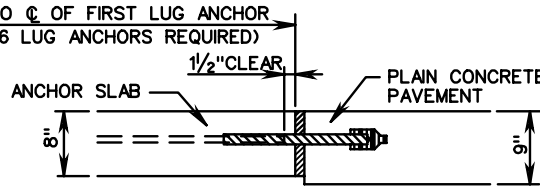
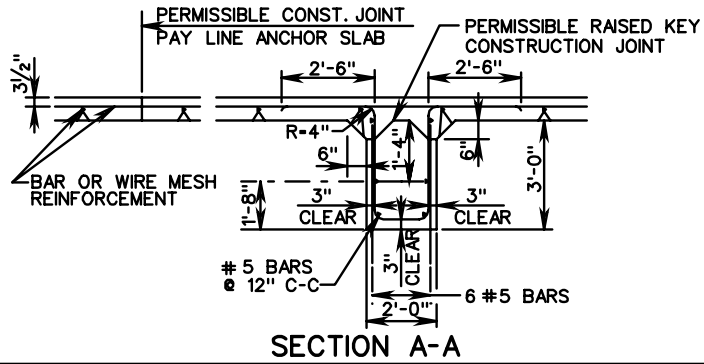

**NOTES:** FOR DOWEL & JOINT DETAILS SEE DETAIL OF TRANSVERSE EXPANSION JOINT PR-2

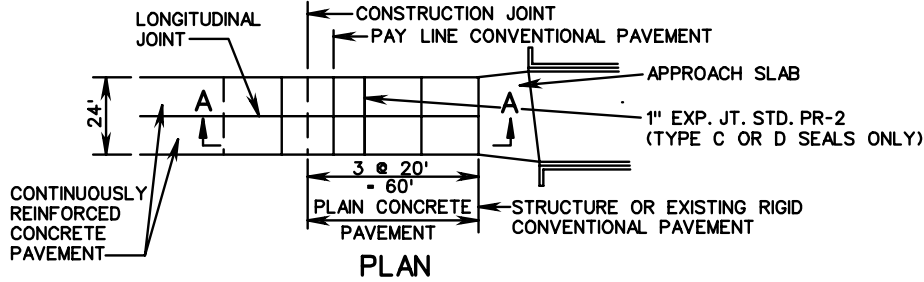
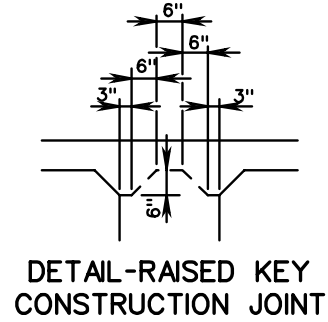

| WF BEAM (WEIGHT AND DIMENSIONS) |                         |              |        |           |               |
|---------------------------------|-------------------------|--------------|--------|-----------|---------------|
| CRCP THICKNESS                  | EMBEDMENT IN "SUB SLAB" | WF BEAM SIZE | FLANGE |           | WEB THICKNESS |
|                                 |                         |              | WIDTH  | THICKNESS |               |
| 8"                              | 6"                      | 14 X 61      | 10"    | 5/8"      | 3/8"          |

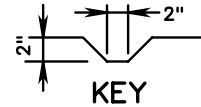

**NOTES:**

CONCRETE SHOULD BE ADEQUATELY VIBRATED UNDER BEAM FLANGE TO ELIMINATE HONEYCOMB.

2" MIN. CONCRETE COVER FOR STEEL IN SUB-SLAB.

WELDED 1/4" STEEL PLATE AT BOTH ENDS OF WF BEAM TO SEAL ENDS.

▨ DENOTES 1" EXPANSION JOINT MATERIAL POLYSTYRENE OR EQUIVALENT)

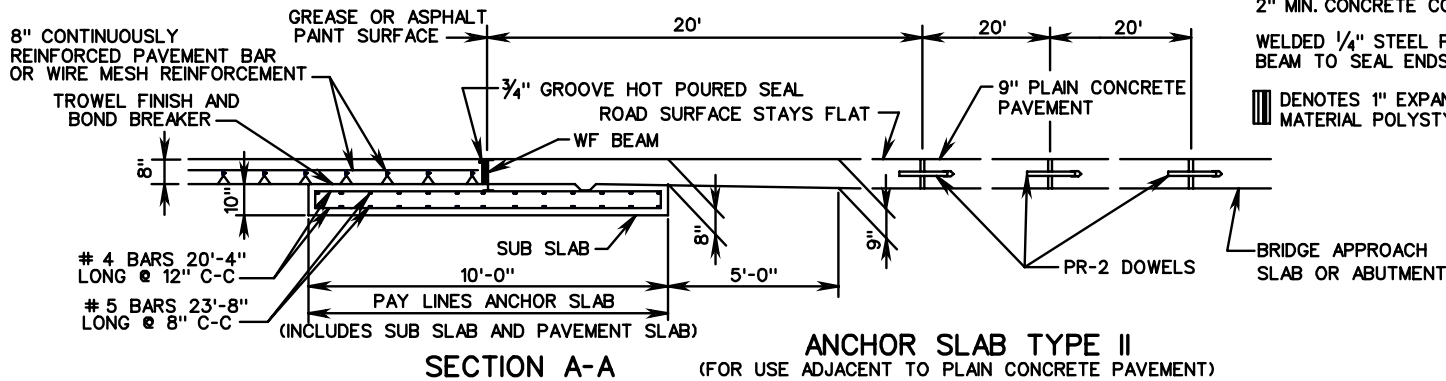

**8" THICK CONTINUOUSLY REINFORCED CONC. PAVE.**  
(FOR USE WITH BAR OR WIRE MESH REINFORCEMENT)

SPECIFICATION REFERENCE

316



ROAD AND BRIDGE STANDARDS

SHEET 3 OF 4

REVISION DATE

301.08

VIRGINIA DEPARTMENT OF TRANSPORTATION

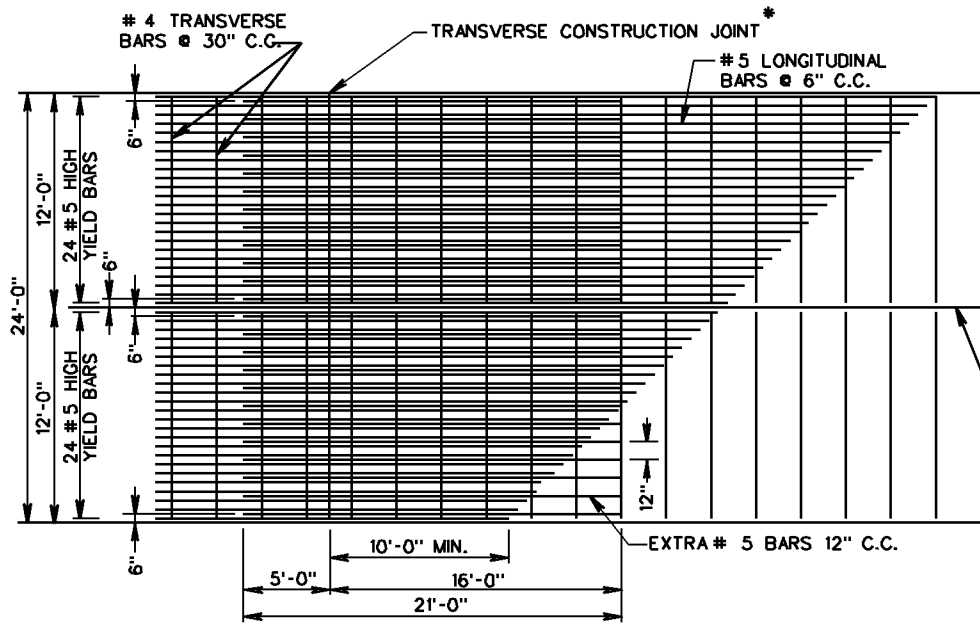

\* LONGITUDINAL STEEL TO CONTINUE THROUGH JOINT.

EXTRA # 5 (GRADE 60) BARS (21' LONG) SHALL BE SPACED AT 12" C.C.

LEAVE OUT JOINT  
FOR USE WITH STEEL BAR REINFORCEMENT

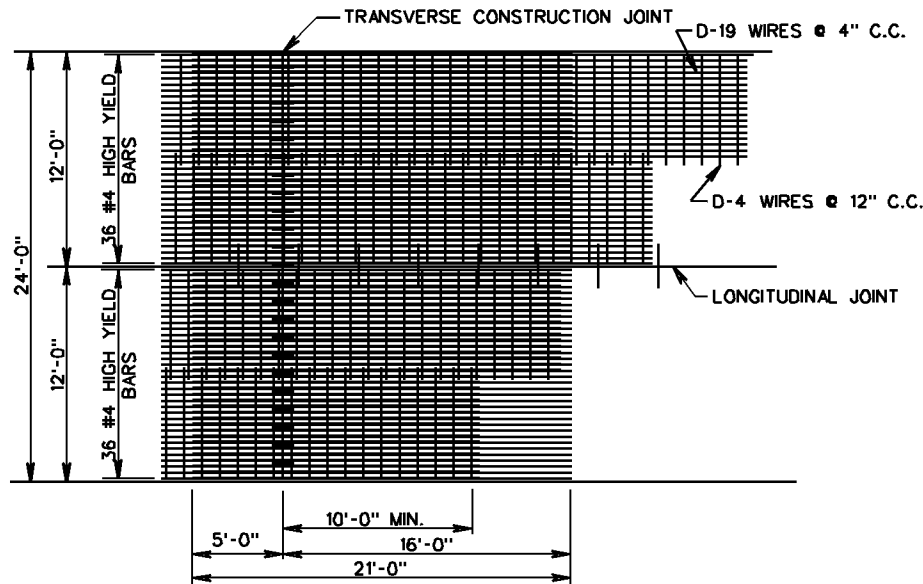

LEAVE OUT JOINT  
FOR USE WITH WIRE MESH REINFORCEMENT

SPECIFICATION  
REFERENCE

316

# 8" THICK CONTINUOUSLY REINFORCED CONC. PAVE.

(LEAVE OUT JOINT DETAIL)

VIRGINIA DEPARTMENT OF TRANSPORTATION

VDOT

ROAD AND BRIDGE STANDARDS

REVISION DATE

4/09

SHEET 4 OF 4

301.09

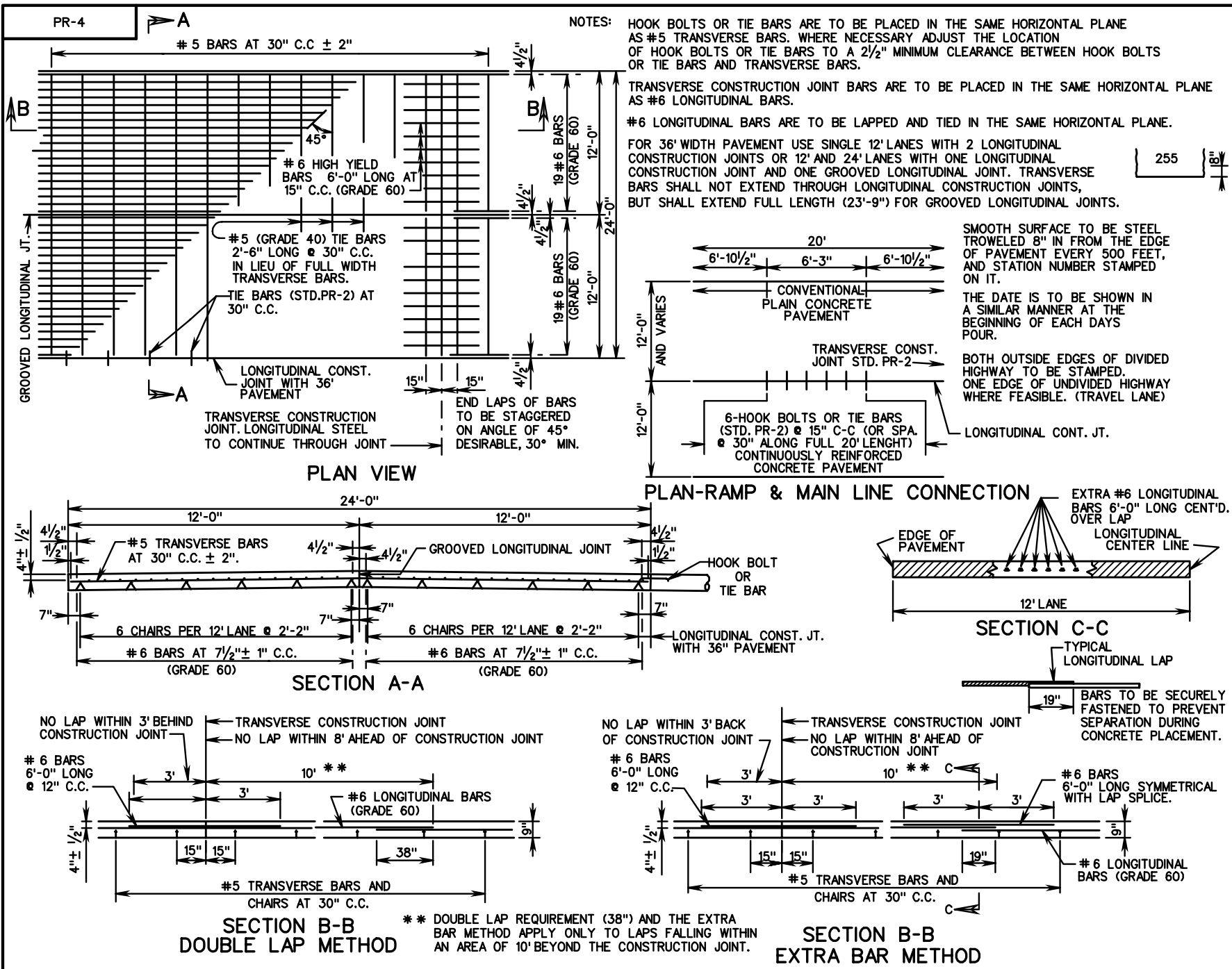

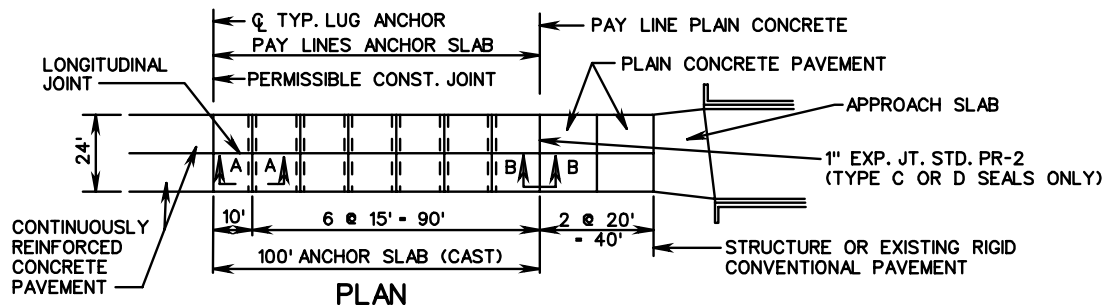

NOTES:  
 CONCRETE FOR LUG ANCHORS SHALL BE POURED AGAINST COMPACTED SUBGRADE. CONCRETE FOR LUGS AND ANCHOR SLAB MAY BE POURED MONOLITHICALLY OR POURED USING RAISED KEY CONSTRUCTION JOINT METHOD.

ADEQUATE CONSOLIDATION OF CONCRETE IN LUGS WILL BE OBTAINED WITHOUT DISPLACING LONGITUDINAL CONTINUOUS STEEL, BY THE USE OF INTERNAL VIBRATION.

WHEN LESS THAN FULL WIDTH LUG AND PAVEMENT SLAB IS PLACED, THE #5 TRANSVERSE STEEL IN THE LUGS SHALL BE EXTENDED, LAPPED AND SPLICED AT LEAST 25 DIAMETERS.

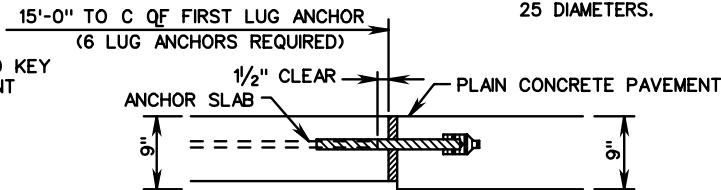
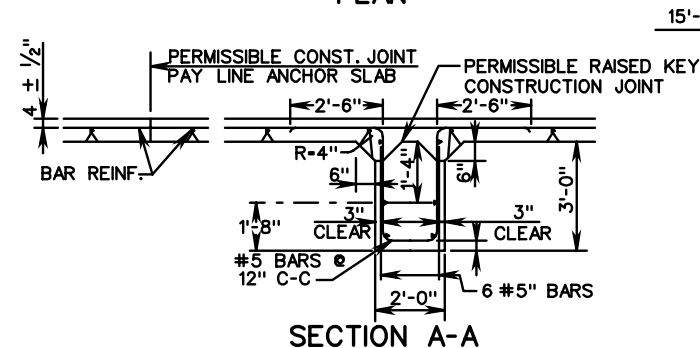

NOTE: FOR DOWEL & JOINT DETAILS SEE DETAIL OF TRANSVERSE EXPANSION JOINT PR-2

**ANCHOR SLAB TYPE I**  
 (FOR USE ADJACENT TO PLAIN CONCRETE PAVEMENT)

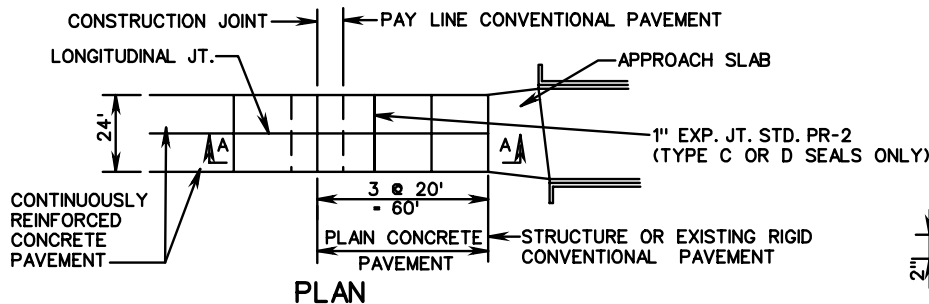
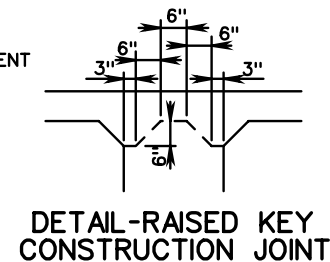

| WF BEAM (WEIGHT AND DIMENSIONS) |                         |              |        |           |               |
|---------------------------------|-------------------------|--------------|--------|-----------|---------------|
| CRCP THICKNESS                  | EMBEDMENT IN "SUB SLAB" | WF BEAM SIZE | FLANGE |           | WEB THICKNESS |
|                                 |                         |              | WIDTH  | THICKNESS |               |
| 9"                              | 6"                      | 14 X 61      | 10"    | 5/8"      | 3/8"          |

NOTES:  
 CONCRETE SHOULD BE ADEQUATELY VIBRATED UNDER BEAM FLANGE TO ELIMINATE HONEYCOMB.  
 2" MIN. CONCRETE COVER FOR STEEL IN SUB-SLAB.  
 WELDED 1/4" STEEL PLATE AT BOTH ENDS OF WF BEAM TO SEAL ENDS.

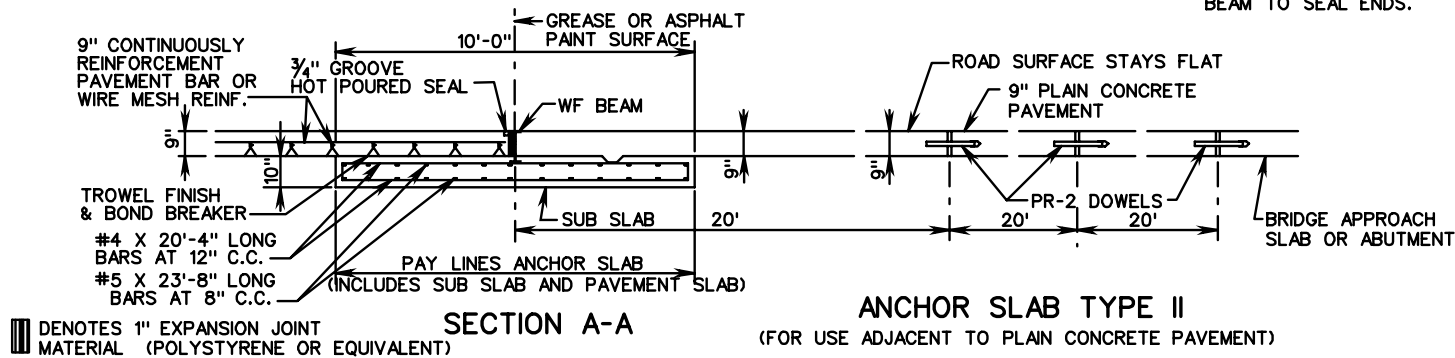
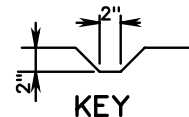

**ANCHOR SLAB TYPE II**  
 (FOR USE ADJACENT TO PLAIN CONCRETE PAVEMENT)

SPECIFICATION REFERENCE

**9" THICK CONTINUOUSLY REINFORCED CONC. PAVE.**  
 (FOR USE WITH BAR REINFORCEMENT ONLY)

316

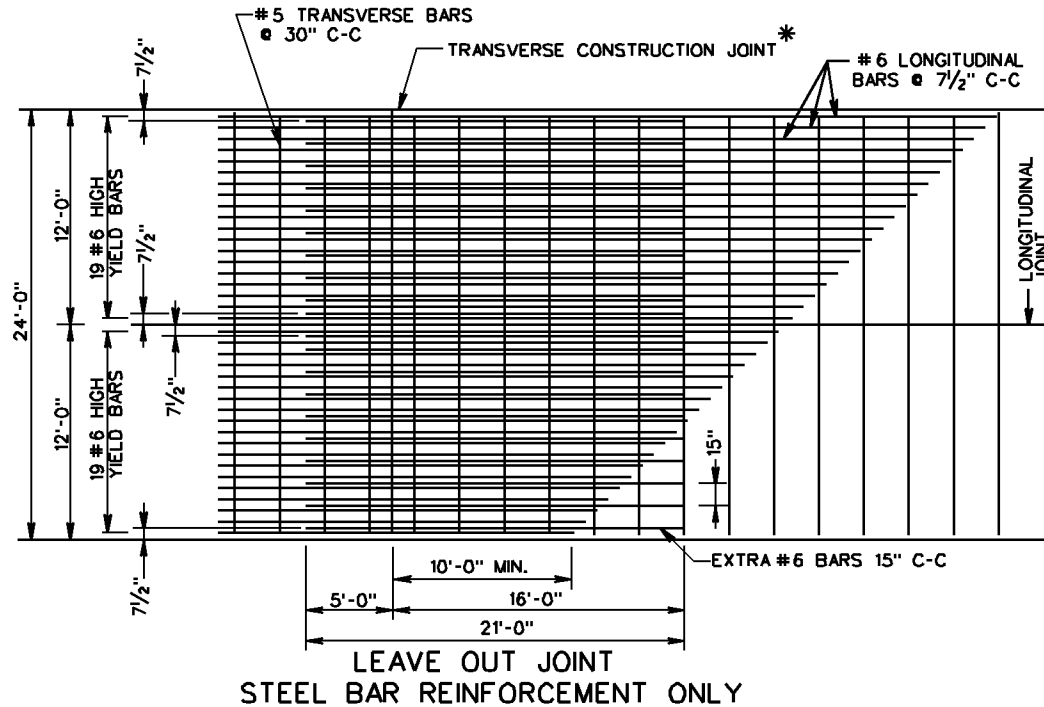

\* LONGITUDINAL STEEL TO CONTINUE THROUGH JOINT.  
EXTRA # 6 (GRADE 60) BARS (21' LONG) SHALL BE SPACED AT 15" C-C.

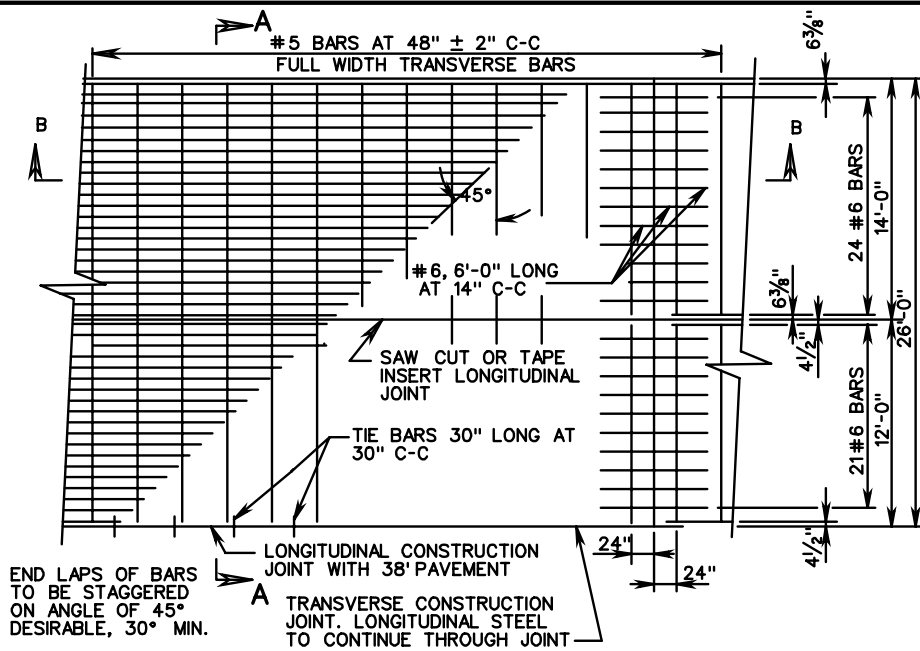

PLAN VIEW  
CONTINUOUSLY REINFORCED CONCRETE PAVEMENT

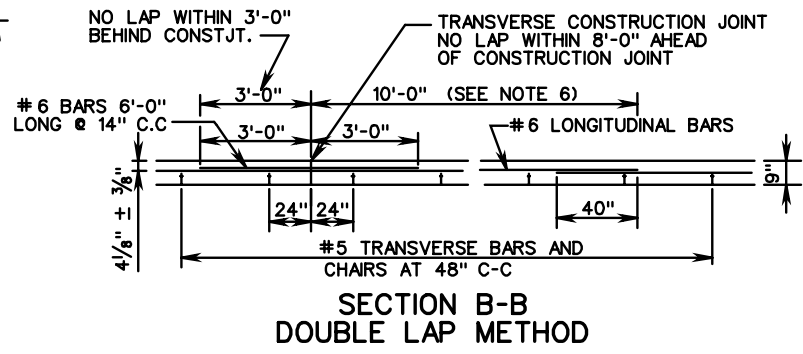

SECTION B-B  
DOUBLE LAP METHOD

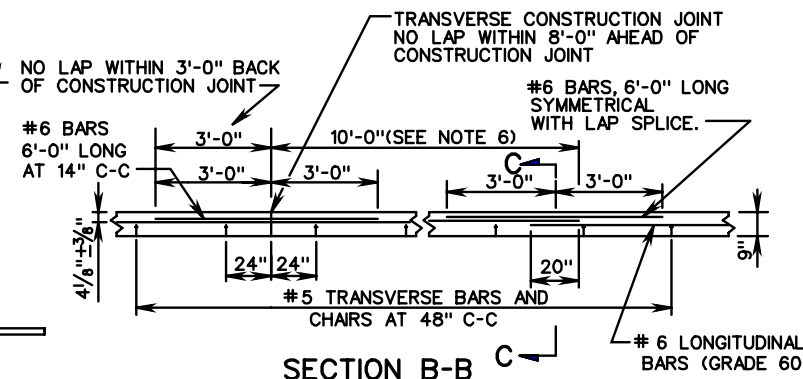

SECTION B-B C  
EXTRA BAR METHOD

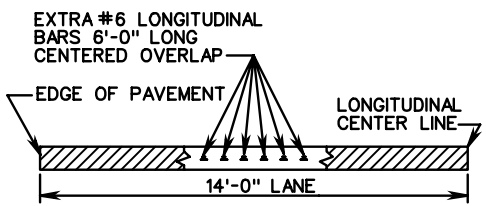

SECTION C-C

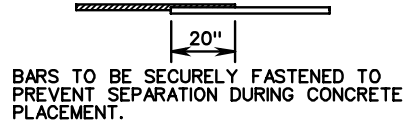

TYPICAL  
LONGITUDINAL LAP

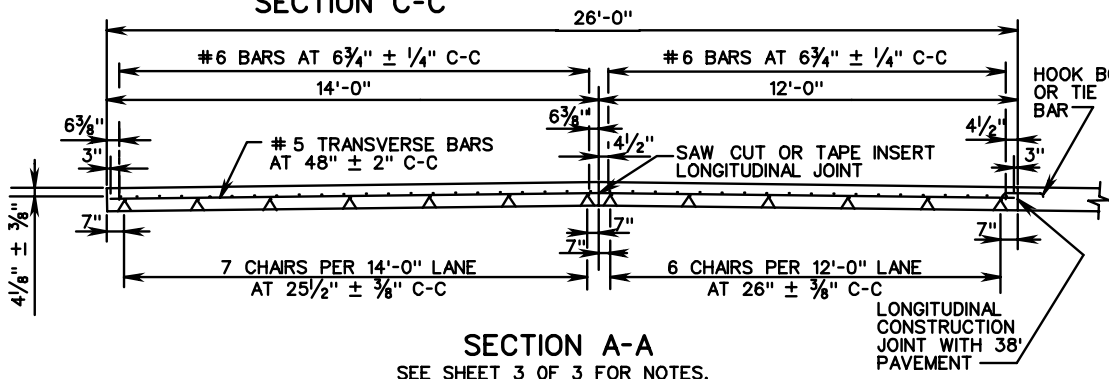

SECTION A-A  
SEE SHEET 3 OF 3 FOR NOTES.

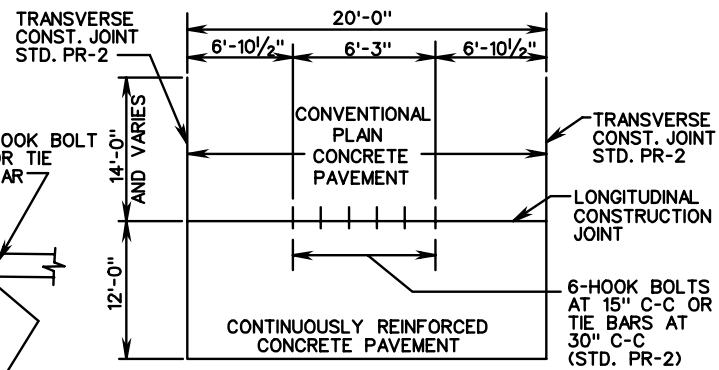

PLAN-RAMP & MAIN LINE CONNECTION

|                         |
|-------------------------|
| SPECIFICATION REFERENCE |
| 316                     |

**9" THICK CONTINUOUSLY REINFORCED CONC. PAVE.**  
(14 FOOT TRAVEL LANE)

VIRGINIA DEPARTMENT OF TRANSPORTATION

|                           |              |
|---------------------------|--------------|
| <b>VDOT</b>               |              |
| ROAD AND BRIDGE STANDARDS |              |
| REVISION DATE             | SHEET 1 OF 3 |
| 301.13                    |              |

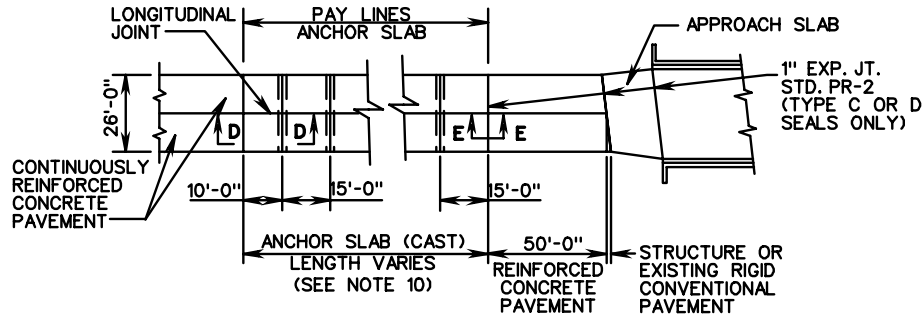

PLAN VIEW ANCHOR SLAB TYPE I

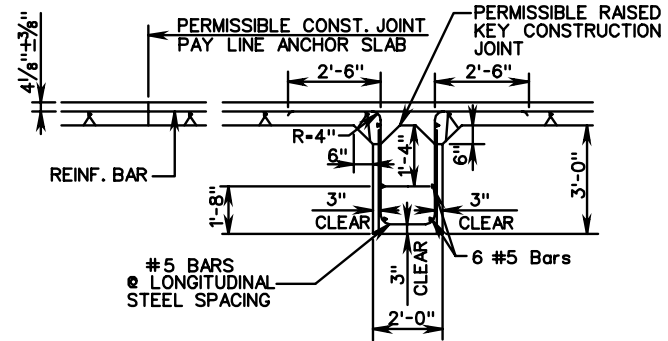

SECTION D-D

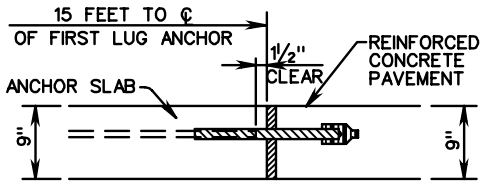

FOR DOWEL & JOINT DETAILS SEE DETAIL OF TRANSVERSE EXPANSION JOINT PR-2

SECTION E-E ANCHOR SLAB TYPE I

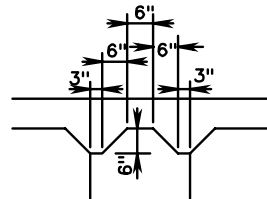

DETAIL-RAISED KEY CONSTRUCTION JOINT

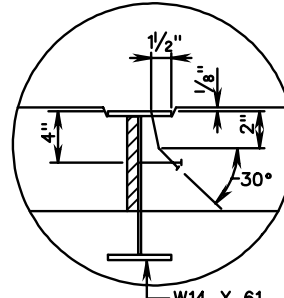

DETAIL A

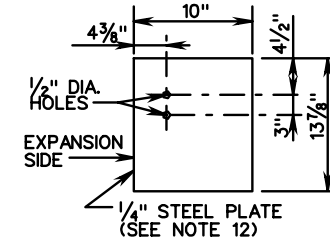

END PLATE DETAIL ANCHOR SLAB TYPE II

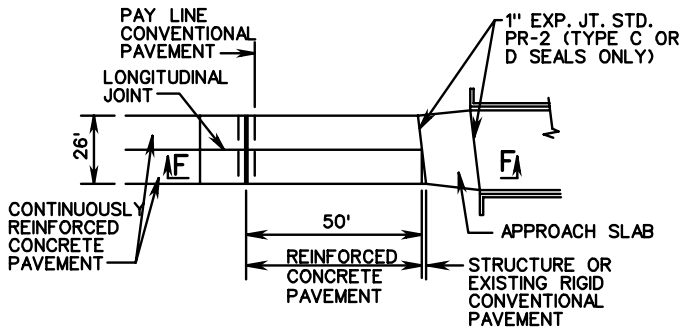

PLAN VIEW ANCHOR SLAB TYPE II (SEE NOTE 11)

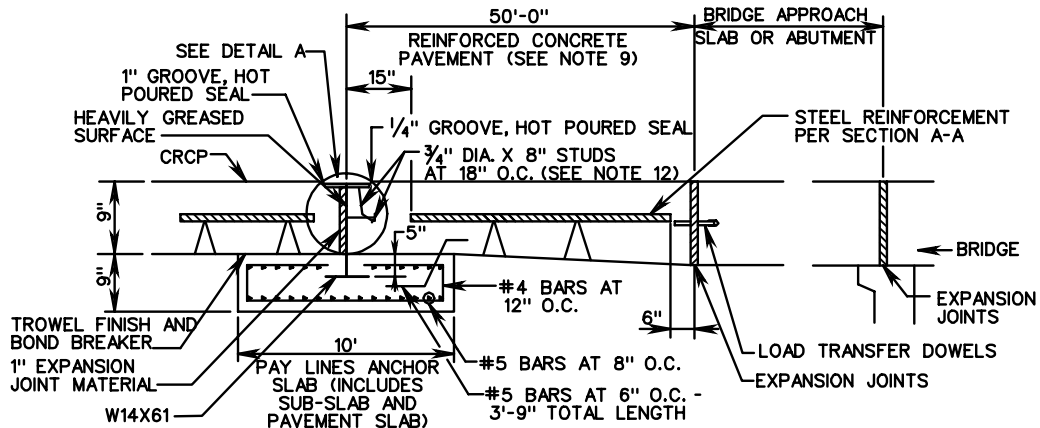

SECTION F-F ANCHOR SLAB TYPE II

SEE SHEET 3 OF 3 FOR NOTES.



ROAD AND BRIDGE STANDARDS

SHEET 2 OF 3

REVISION DATE

301.14

9" THICK CONTINUOUSLY REINFORCED CONC. PAVE.

(14 FOOT TRAVEL LANE)

VIRGINIA DEPARTMENT OF TRANSPORTATION

SPECIFICATION REFERENCE

316



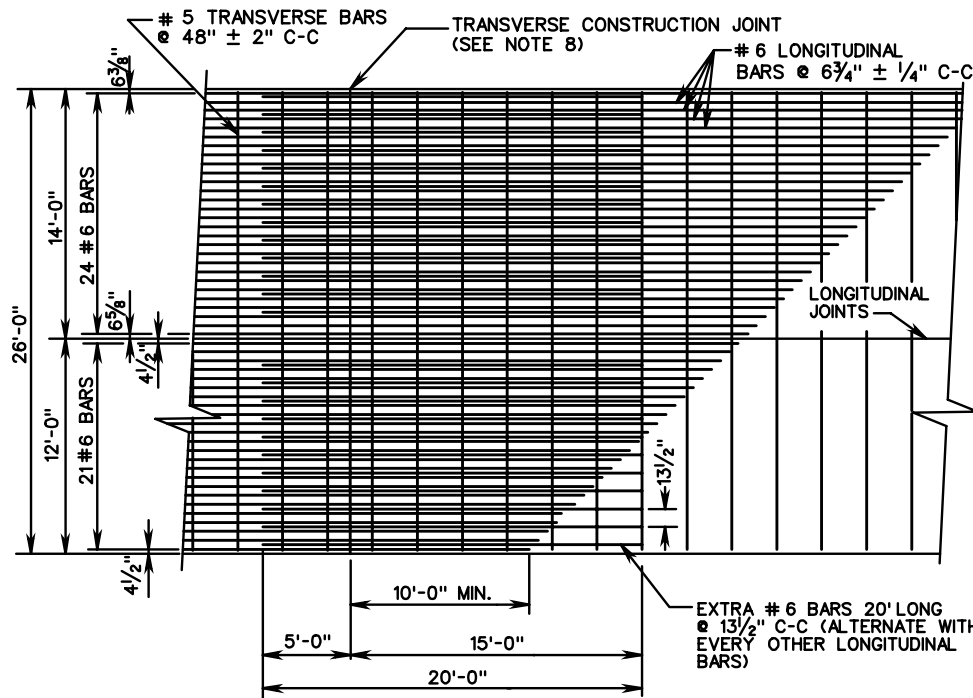

PLAN VIEW  
LEAVE OUT JOINT  
STEEL BAR REINFORCEMENT ONLY

**NOTES:**

1. HOOK BOLTS OR TIE BARS ARE TO BE PLACED IN THE SAME HORIZONTAL PLANE AS THE # 5 TRANSVERSE BARS. WHERE NECESSARY, ADJUST THE LOCATION OF THE HOOK BOLTS OR TIE BARS TO A 2 1/2" MINIMUM CLEARANCE BETWEEN HOOK BOLTS OR TIE BARS AND TRANSVERSE BARS.
2. TRANSVERSE CONSTRUCTION JOINT BARS ARE TO BE PLACED IN THE SAME HORIZONTAL PLANE AS THE #6 LONGITUDINAL BARS.
3. # 6 LONGITUDINAL BARS ARE TO BE LAPPED AND TIED IN THE SAME HORIZONTAL PLANE.
4. FOR THE 38 FOOT WIDTH PAVEMENT USE SINGLE 12 FOOT LANES WITH TWO LONGITUDINAL CONSTRUCTION JOINTS OR 12 FOOT AND 14 FOOT LANES WITH ONE LONGITUDINAL CONSTRUCTION JOINT AND ONE SAW CUT OR TAPE INSERT LONGITUDINAL JOINT. TRANSVERSE BARS SHALL NOT EXTEND THROUGH LONGITUDINAL CONSTRUCTION JOINTS, BUT SHALL EXTEND FULL LENGTH (25'-6") FOR SAW CUT OR TAPE INSERT LONGITUDINAL JOINT.
5. SMOOTH SURFACE TO BE STEEL TROWELED 8" IN FROM EDGE OF PAVEMENT EVERY 500 FT., AND THE STATION NUMBER STAMPED INTO IT AS SHOWN BELOW. THE DATE IS TO BE SHOWN IN A SIMILIAR MANNER AT THE BEGINNING OF EACH DAYS POUR. BOTH OUTSIDE EDGES OF DIVIDED HIGHWAY IS TO BE STAMPED. ONE EDGE OF UNDIVIDED HIGHWAY WHERE FEASIBLE (TRAVEL LANE).
6. DOUBLE LAP REQUIREMENT (40") AND THE EXTRA BAR METHOD APPLY ONLY TO LAPS FALLING WITHIN AN AREA OF 10' BEYOND THE CONSTRUCTION JOINT.
7. CONCRETE FOR LUG ANCHORS SHALL BE POURED AGAINST COMPACTED SUBGRADE. CONCRETE FOR LUGS AND ANCHOR SLAB MAY BE POURED MONOLITHICALLY OR POURED USING RAISED KEY CONSTRUCTION JOINT METHOD. ADEQUATE CONSOLIDATION OF CONCRETE IN LUGS WILL BE OBTAINED WITHOUT DISPLACING LONGITUDINAL CONTINUOUS STEEL, BY THE USE OF INTERNAL VIBRATION. WHEN LESS THAN FULL WIDTH LUG AND PAVEMENT SLAB IS PLACED, THE # 5 TRANSVERSE STEEL IN THE LUGS SHALL BE EXTENDED, LAPPED AND SPLICED AT LEAST 25 DIAMETERS.
8. LONGITUDINAL STEEL TO CONTINUE THROUGH JOINT. EXTRA #6 BARS 20' LONG SHALL BE SPACED AT 13 1/2" C-C.
9. CONCRETE SHOULD BE ADEQUATELY VIBRATED UNDER BEAM FLANGE TO ELIMINATE HONEYCOMBS.
10. IN CONDITIONS OF SOFT CLAY UNDERLYING SOILS (AASHTO SOIL CLASSIFICATION OF GROUP A-4, A-5, A-6, OR A-7) INCLUSIVE OF SUBGROUPS (PER AASHTO MATERIALS SPECIFICATIONS M 145), AN ANCHOR SLAB TYPE I UTILIZING 5 ANCHOR LUGS (ANCHOR SLAB LENGTH = 85') OR AN ANCHOR SLAB TYPE II SHALL BE USED. REINFORCEMENT STEEL SIZE AND SPACING WILL BE THE SAME AS THE CONTINUOUS CONCRETE PAVEMENT.  
  
IN CONDITIONS OF GRANULAR UNDERLYING SOILS ONLY (AASHTO SOIL CLASSIFICATION OF GROUP A-1, A-2, OR A-3) INCLUSIVE OF SUBGROUPS (PER AASHTO MATERIALS SPECIFICATIONS M 145), AN ANCHOR SLAB TYPE I UTILIZING 3 ANCHOR LUGS (ANCHOR SLAB LENGTH = 55') OR AN ANCHOR SLAB TYPE II MAY BE USED. REINFORCEMENT STEEL SIZE AND SPACING WILL BE THE SAME AS THE CONTINUOUS CONCRETE PAVEMENT.
11. WELD STEEL END PLATE TO BOTH ENDS OF WF BEAM TO SEAL ENDS. WELD SHEAR CONNECTORS TO WEB AND FLANGE OF WF BEAM.
12. 2 INCH MINIMUM CONCRETE COVER FOR STEEL IN SUB-SLABS.
13. WIDE FLANGE BEAM TO BE TREATED WITH CORROSION INHIBITOR PER SECTION 407 OF THE ROAD AND BRIDGE SPECIFICATIONS.
14. ALL REINFORCED BARS SHALL BE GRADE 60 STEEL.
15. THE USE OF TUBE FEEDING TO PLACE REINFORCEMENT IN PLASTIC CONCRETE WILL NOT BE ALLOWED.

|                                       |  |  |
|---------------------------------------|--|--|
| SPECIFICATION<br>REFERENCE<br><br>316 | <h2 style="margin: 0;">9" THICK CONTINUOUSLY REINFORCED CONC. PAVE.</h2> <p style="margin: 0;">(14 FOOT TRAVEL LANE)</p> <p style="margin: 0;">VIRGINIA DEPARTMENT OF TRANSPORTATION</p> | ROAD AND BRIDGE STANDARDS<br>REVISION DATE      SHEET 3 OF 3<br>301.15 |
|---------------------------------------|--|--|

PR-6

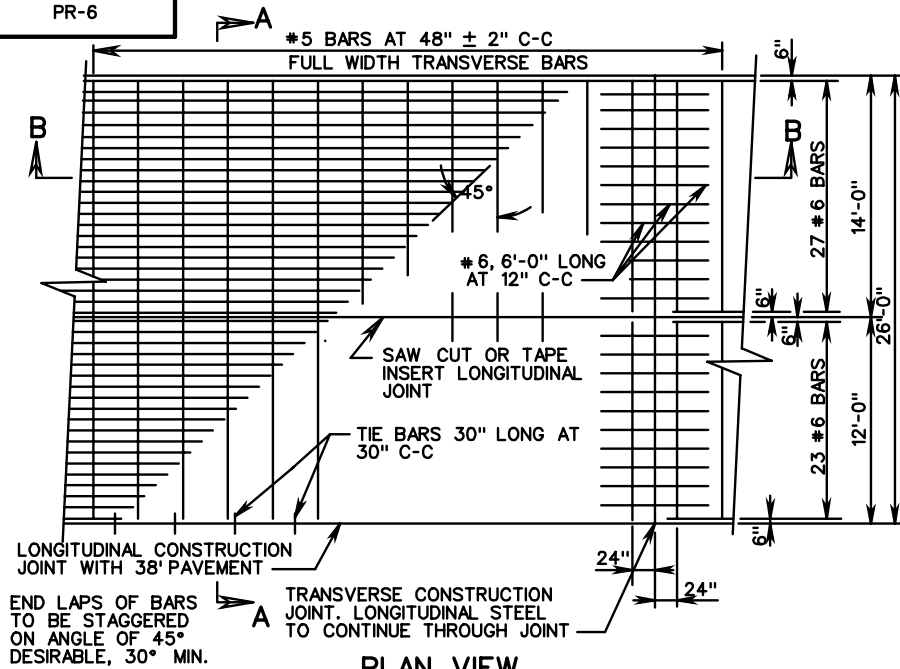

PLAN VIEW  
CONTINUOUSLY REINFORCED CONCRETE PAVEMENT

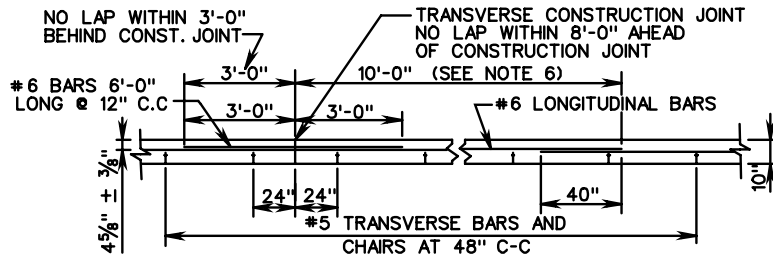

SECTION B-B  
DOUBLE LAP METHOD

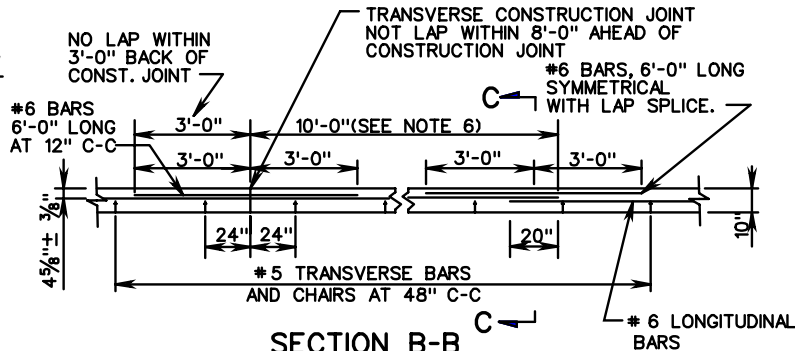

SECTION B-B  
EXTRA BAR METHOD

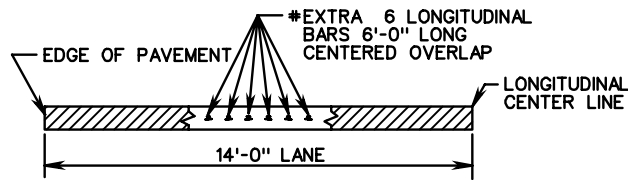

SECTION C-C

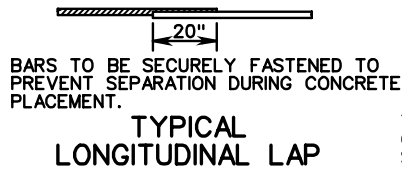

TYPICAL  
LONGITUDINAL LAP

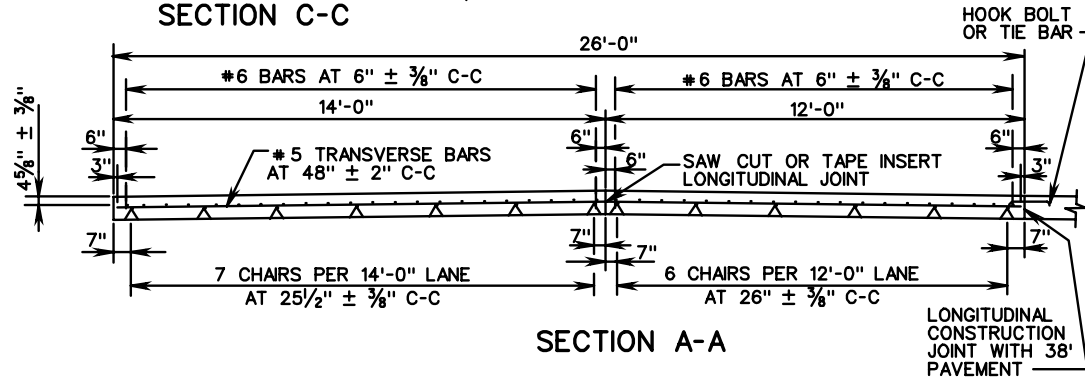

SECTION A-A

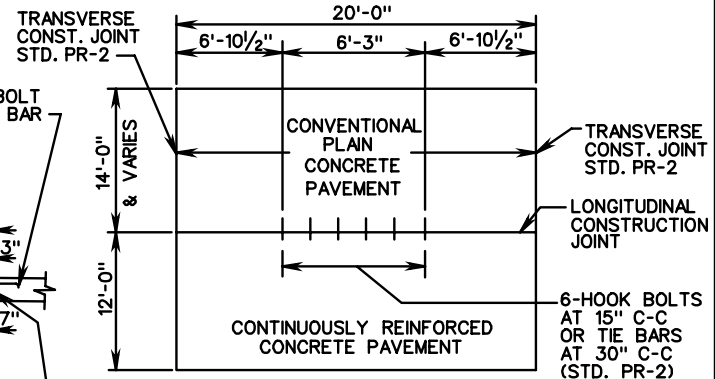

PLAN-RAMP & MAIN LINE CONNECTION

SEE SHEET 3 OF 3 FOR NOTES.



ROAD AND BRIDGE STANDARDS

SHEET 1 OF 3

REVISION DATE

301.16

# 10" THICK CONTINUOUSLY REINFORCED CONC. PAVE. (14 FOOT TRAVEL LANE)

VIRGINIA DEPARTMENT OF TRANSPORTATION

SPECIFICATION  
REFERENCE

316

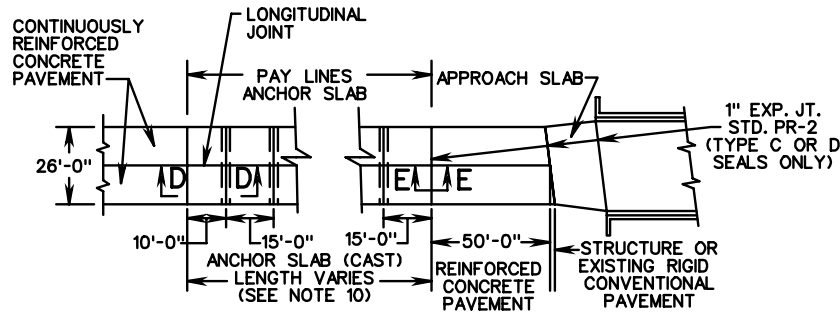

PLAN VIEW  
ANCHOR SLAB TYPE I

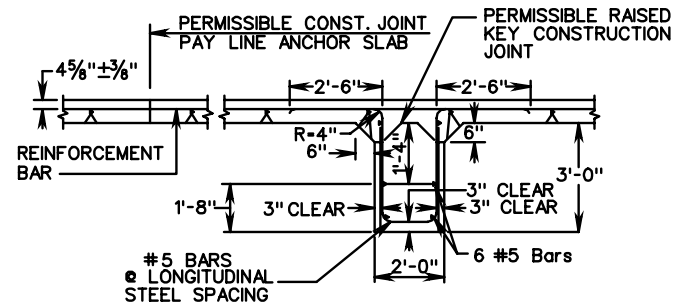

SECTION D-D

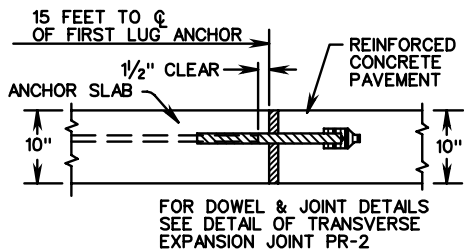

SECTION E-E  
ANCHOR SLAB TYPE I

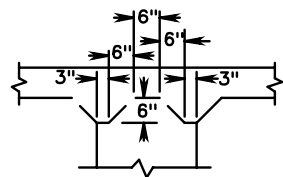

DETAIL-RAISED KEY  
CONSTRUCTION JOINT

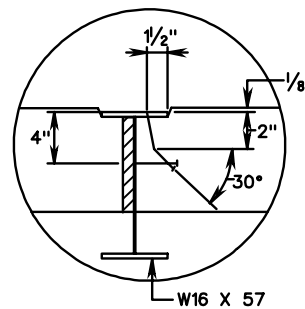

DETAIL A

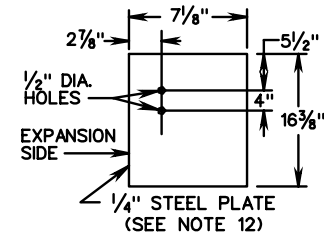

ANCHOR SLAB TYPE II  
END PLATE DETAIL

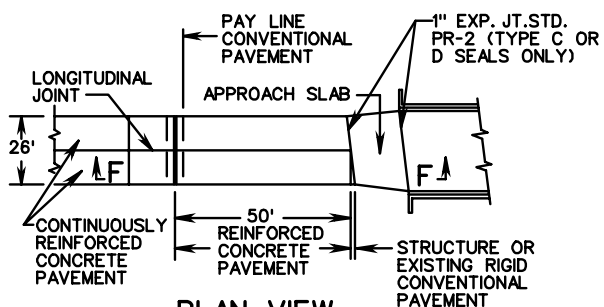

PLAN VIEW  
ANCHOR SLAB TYPE II  
(SEE NOTE 11)

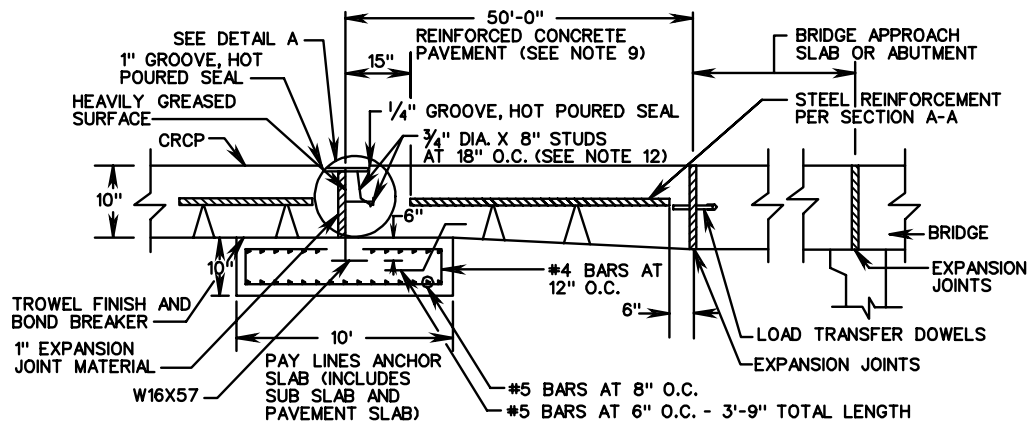

SECTION F-F  
ANCHOR SLAB TYPE II

SEE SHEET 3 OF 3 FOR NOTES

|                                       |  |
|---------------------------------------|--|
| SPECIFICATION REFERENCE               | <h2 style="margin: 0;">10" THICK COUNTINUOUSLY REINFORCED CONC. PAVE.</h2> <p style="margin: 0;">(14 FOOT TRAVEL LANE)</p> |
| 316                                   |  |
| VIRGINIA DEPARTMENT OF TRANSPORTATION |  |

|                                  |              |
|----------------------------------|--------------|
| <b>ROAD AND BRIDGE STANDARDS</b> |              |
| REVISION DATE                    | SHEET 2 OF 3 |
| 301.17                           |              |

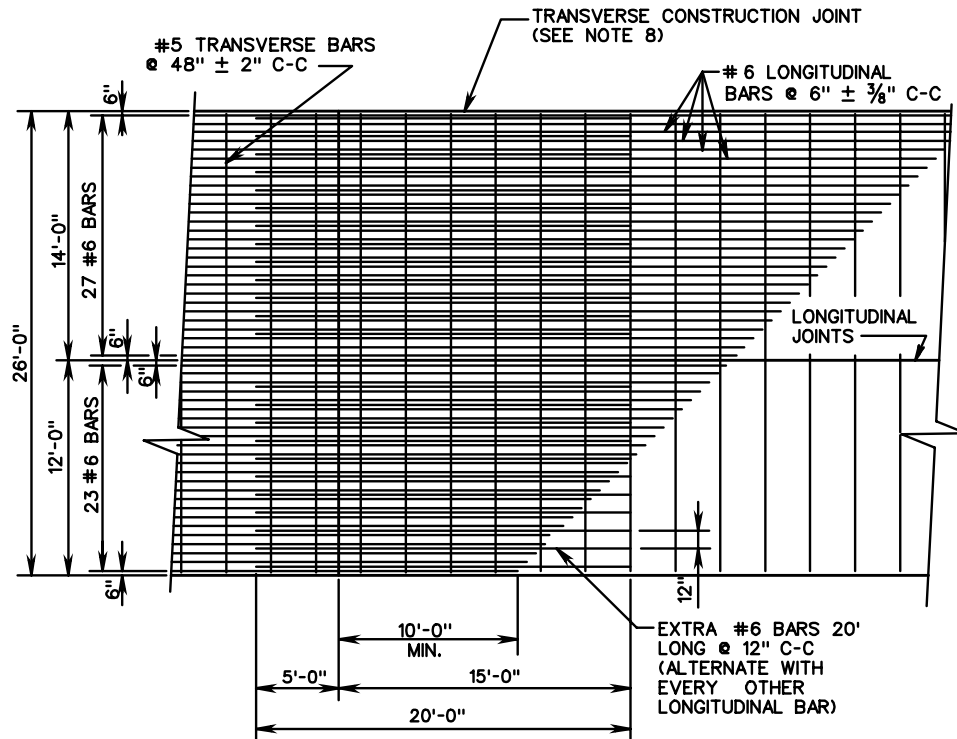

PLAN VIEW  
LEAVE OUT JOINT  
STEEL BAR REINFORCEMENT ONLY

## NOTES:

- HOOK BOLTS OR TIE BARS ARE TO BE PLACED IN THE SAME HORIZONTAL PLANE AS THE #5 TRANSVERSE BARS. WHERE NECESSARY, ADJUST THE LOCATION OF THE HOOK BOLTS OR TIE BARS TO A 2½" MINIMUM CLEARANCE BETWEEN HOOK BOLTS OR TIE BARS AND TRANSVERSE BARS.
- TRANSVERSE CONSTRUCTION JOINT BARS ARE TO BE PLACED IN THE SAME HORIZONTAL PLANE AS THE #6 LONGITUDINAL BARS.
- #6 LONGITUDINAL BARS ARE TO BE LAPPED AND TIED IN THE SAME HORIZONTAL PLANE.
- FOR THE 38 FT. WIDTH PAVEMENT USE SINGLE 12 FOOT LANES WITH TWO LONGITUDINAL CONSTRUCTION JOINTS OR 12 FT. AND 14 FT. LANES WITH ONE LONGITUDINAL CONSTRUCTION JOINT AND ONE SAW CUT OR TAPE INSERT LONGITUDINAL JOINT. TRANSVERSE BARS SHALL NOT EXTEND THROUGH LONGITUDINAL CONSTRUCTION JOINTS, BUT SHALL EXTEND FULL LENGTH (25'-6") FOR SAW CUT OR TAPE INSERT LONGITUDINAL JOINT.
- SMOOTH SURFACE TO BE STEEL TROWELED 8" IN FROM EDGE OF PAVEMENT EVERY 500 FT., AND THE STATION NUMBER STAMPED INTO IT AS SHOWN BELOW. THE DATE IS TO BE SHOWN IN A SIMILAR MANNER AT THE BEGINNING OF EACH DAYS POUR. BOTH OUTSIDE EDGES OF DIVIDED HIGHWAY IS TO BE STAMPED. ONE EDGE OF UNDIVIDED HIGHWAY WHERE FEASIBLE (TRAVEL LANE).
- DOUBLE LAP REQUIREMENT (40") AND THE EXTRA BAR METHOD APPLY ONLY TO LAPS FALLING WITHIN AN AREA OF 10' BEYOND THE CONSTRUCTION JOINT.
- CONCRETE FOR LUG ANCHORS SHALL BE POURED AGAINST COMPACTED SUBGRADE. CONCRETE FOR LUGS AND ANCHOR SLAB MAY BE POURED MONOLITHICALLY OR POURED USING RAISED KEY CONSTRUCTION JOINT METHOD. ADEQUATE CONSOLIDATION OF CONCRETE IN LUGS WILL BE OBTAINED WITHOUT DISPLACING LONGITUDINAL CONTINUOUS STEEL, BY THE USE OF INTERNAL VIBRATION. WHEN LESS THAN FULL WIDTH LUG AND PAVEMENT SLAB IS PLACED, THE #5 TRANSVERSE STEEL IN THE LUGS SHALL BE EXTENDED, LAPPED AND SPLICED AT LEAST 25 DIA.
- LONGITUDINAL STEEL TO CONTINUE THROUGH JOINT. EXTRA #6 BARS 20' LONG SHALL BE SPACED AT 13½" C-C.
- CONCRETE SHOULD BE ADEQUATELY VIBRATED UNDER BEAM FLANGE TO ELIMINATE HONEYCOMBS.
- IN CONDITIONS OF SOFT CLAY UNDERLYING SOILS (AASHTO SOIL CLASSIFICATION OF GROUP A-4, A-5, A-6, OR A-7) INCLUSIVE OF SUBGROUPS (PER AASHTO MATERIALS SPECIFICATIONS M 145), AN ANCHOR SLAB TYPE I UTILIZING 5 ANCHOR LUGS (ANCHOR SLAB LENGTH = 85') OR AN ANCHOR SLAB TYPE II SHALL BE USED. REINFORCEMENT STEEL SIZE AND SPACING WILL BE THE SAME AS THE CONTINUOUS CONCRETE PAVEMENT.  
  
IN CONDITIONS OF GRANULAR UNDERLYING SOILS ONLY (AASHTO SOIL CLASSIFICATION OF GROUP A-1, A-2, OR A-3) INCLUSIVE OF SUBGROUPS (PER AASHTO MATERIALS SPECIFICATIONS M 145), AN ANCHOR SLAB TYPE I UTILIZING 3 ANCHOR LUGS (ANCHOR SLAB LENGTH = 55') OR AN ANCHOR SLAB TYPE II MAY BE USED. REINFORCEMENT STEEL SIZE AND SPACING WILL BE THE SAME AS THE CONTINUOUS CONCRETE PAVEMENT.
- WELD STEEL END PLATE TO BOTH ENDS OF WF BEAM TO SEAL ENDS. WELD SHEAR CONNECTORS TO WEB AND FLANGE OF WF BEAM.
- 2 INCH MINIMUM CONCRETE COVER FOR STEEL IN SUB-SLABS.
- WIDE FLANGE BEAM TO BE TREATED WITH CORROSION INHIBITOR PER SECTION 407 OF THE ROAD AND BRIDGE SPECIFICATIONS.
- ALL REINFORCED BARS SHALL BE GRADE 60 STEEL.
- THE USE OF TUBE FEEDING TO PLACE REINFORCEMENT IN PLASTIC CONCRETE WILL NOT BE ALLOWED.

VDOT

ROAD AND BRIDGE STANDARDS

SHEET 3 OF 3

REVISION DATE

301.18

## 10" THICK CONTINUOUSLY REINFORCED CONC. PAVE. (14 FOOT TRAVEL LANE)

VIRGINIA DEPARTMENT OF TRANSPORTATION

SPECIFICATION  
REFERENCE

316

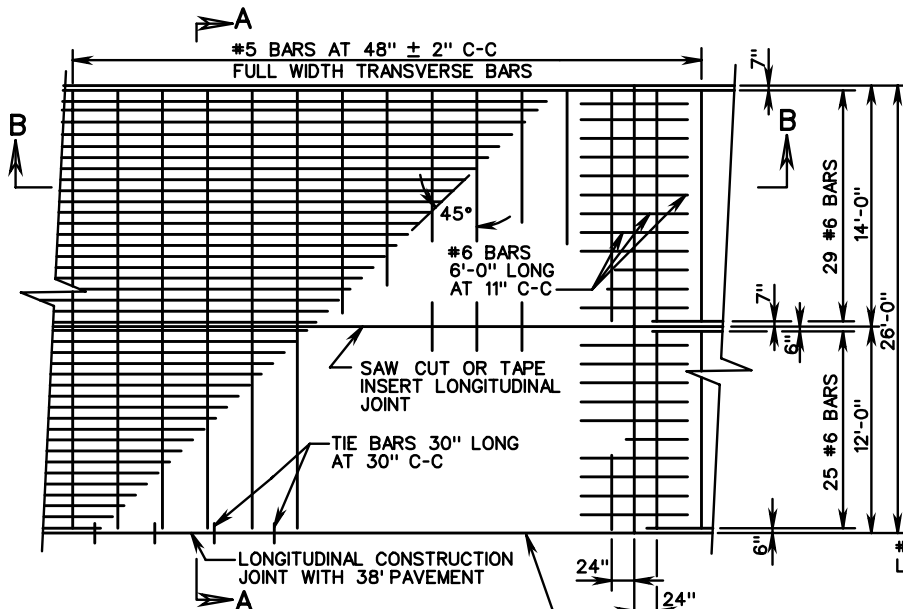

**PLAN VIEW**  
CONTINUOUSLY REINFORCED CONCRETE PAVEMENT

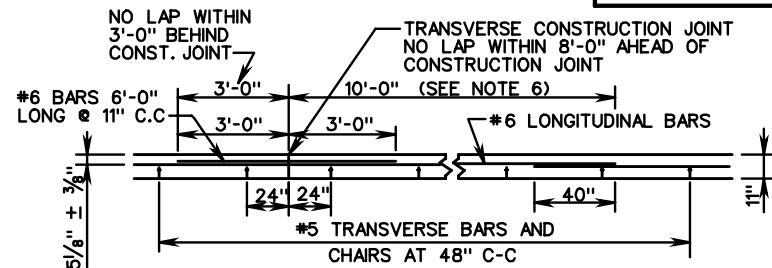

**SECTION B-B**  
DOUBLE LAP METHOD

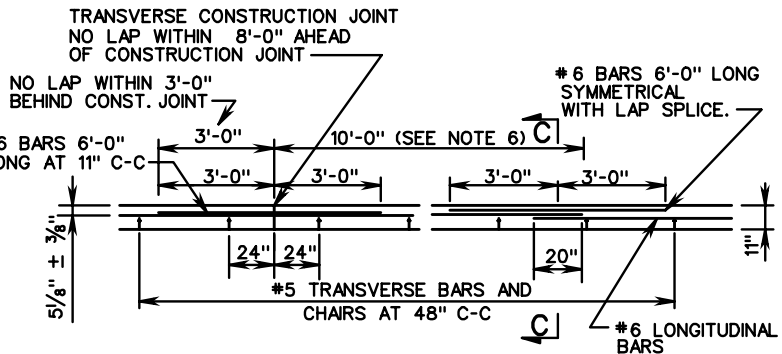

**SECTION B-B**  
EXTRA BAR METHOD

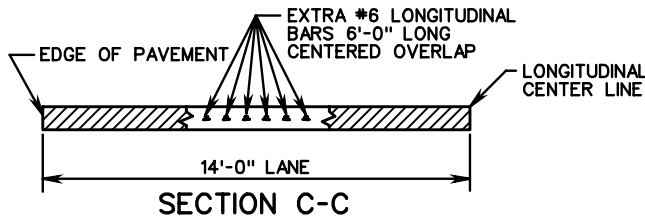

**SECTION C-C**



**TYPICAL**  
LONGITUDINAL LAP

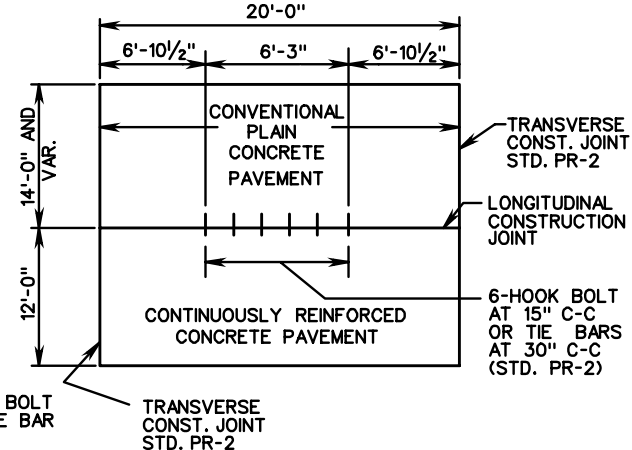

**PLAN-RAMP & MAIN LINE**  
CONNECTION

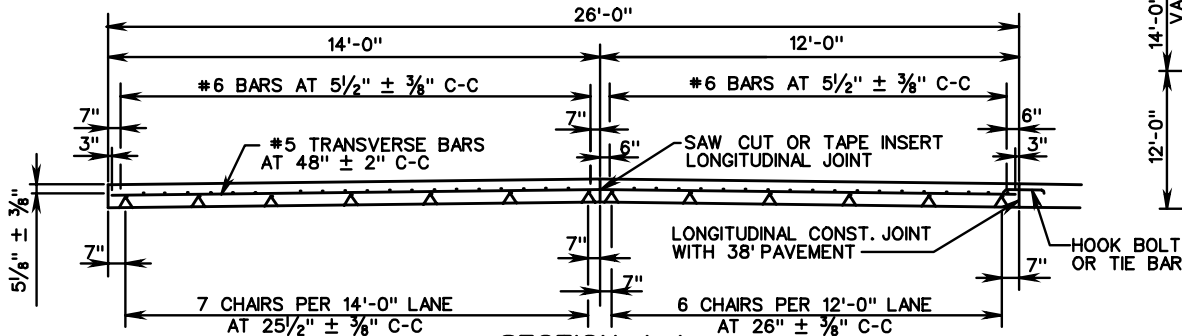

**SECTION A-A**

SEE SHEET 3 OF 3 FOR NOTES

SPECIFICATION REFERENCE

316

**11" THICK CONTINUOUSLY REINFORCED CONC. PAVE.**

(14 FOOT TRAVEL LANE)

VIRGINIA DEPARTMENT OF TRANSPORTATION

**VDOT**

ROAD AND BRIDGE STANDARDS

REVISION DATE

SHEET 1 OF 3

301.19

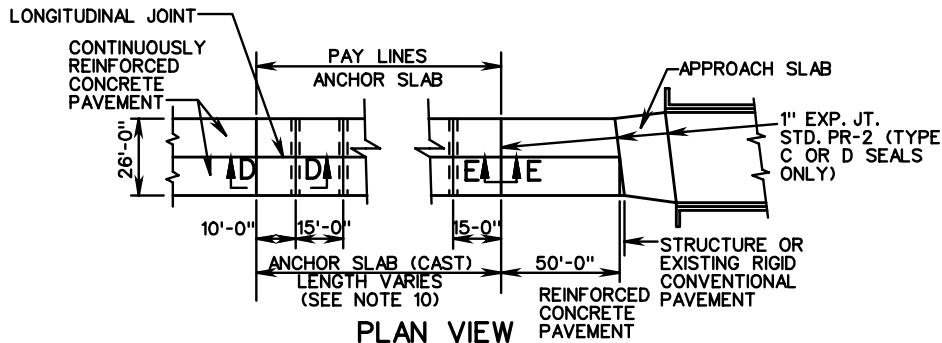

PLAN VIEW ANCHOR SLAB TYPE I

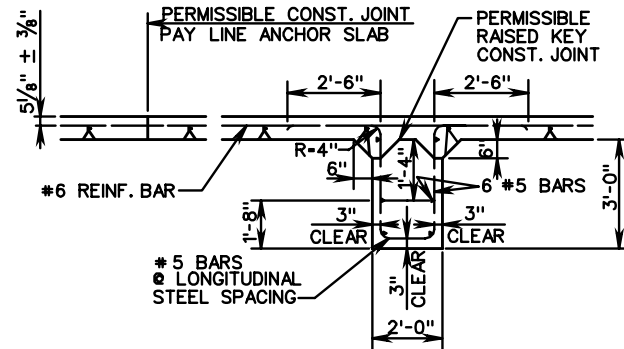

SECTION D-D

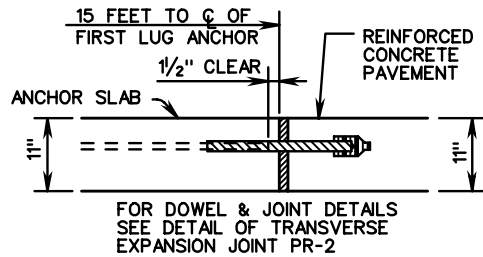

SECTION E-E ANCHOR SLAB TYPE I

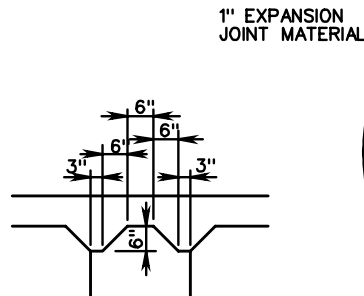

DETAIL-RAISED KEY CONSTRUCTION JOINT

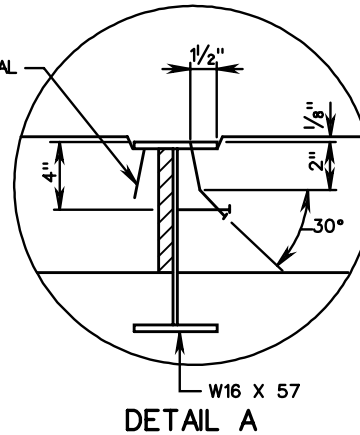

DETAIL A

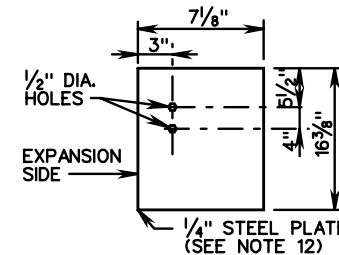

ANCHOR SLAB TYPE II END PLATE DETAIL

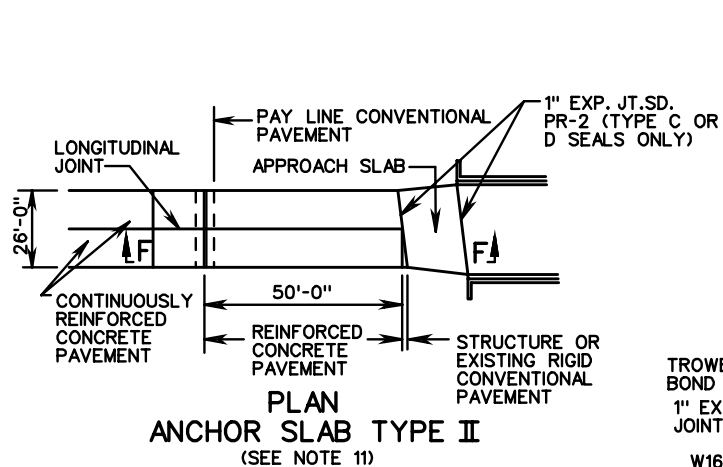

PLAN ANCHOR SLAB TYPE II (SEE NOTE 11)

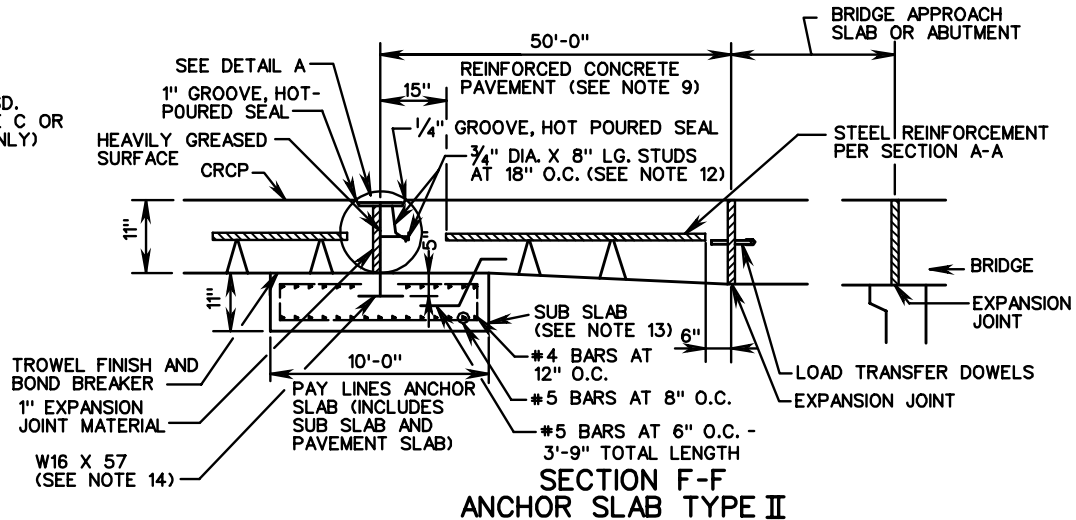

SECTION F-F ANCHOR SLAB TYPE II

SEE SHEET 3 OF 3 FOR NOTES



ROAD AND BRIDGE STANDARDS

11" THICK CONTINUOUSLY REINFORCED CONC. PAVE.  
(14 FOOT TRAVEL LANE)

SPECIFICATION REFERENCE

SHEET 2 OF 3

REVISION DATE

VIRGINIA DEPARTMENT OF TRANSPORTATION

301.20

316

**NOTES:**

1. HOOK BOLTS OR TIE BARS ARE TO BE PLACED IN THE SAME HORIZONTAL PLANE AS THE #5 TRANSVERSE BARS. WHERE NECESSARY, ADJUST THE LOCATION OF THE HOOK BOLTS OR TIE BARS TO A 2 1/2" MINIMUM CLEARANCE BETWEEN HOOK BOLTS OR TIE BARS AND TRANSVERSE BARS.
  2. TRANSVERSE CONSTRUCTION JOINT BARS ARE TO BE PLACED IN THE SAME HORIZONTAL PLANE AS THE #6 LONGITUDINAL BARS.
  3. #6 LONGITUDINAL BARS ARE TO BE LAPPED AND TIED IN THE SAME HORIZONTAL PLANE.
  4. FOR THE 38 FOOT WIDTH PAVEMENT USE SINGLE 12 FOOT LANES WITH TWO LONGITUDINAL CONSTRUCTION JOINTS OR 12 FOOT AND 14 FOOT LANES WITH ONE LONGITUDINAL CONSTRUCTION JOINT AND ONE SAW CUT OR TAPE INSERT LONGITUDINAL JOINT. TRANSVERSE BARS SHALL NOT EXTEND THROUGH LONGITUDINAL CONSTRUCTION JOINTS, BUT SHALL EXTEND FULL LENGTH (25'-6") FOR SAW CUT OR TAPE INSERT LONGITUDINAL JOINT.
  5. SMOOTH SURFACE TO BE STEEL TROWELED 8" IN FROM EDGE OF PAVEMENT EVERY 500 FT., AND THE STATION NUMBER STAMPED INTO IT AS SHOWN BELOW. THE DATE IS TO BE SHOWN IN A SIMILAR MANNER AT THE BEGINNING OF EACH DAYS POUR. BOTH OUTSIDE EDGES OF DIVIDED HIGHWAY ARE TO BE STAMPED. ONE EDGE OF UNDIVIDED HIGHWAY WHERE FEASIBLE (TRAVEL LANE).
- 
6. DOUBLE LAP REQUIREMENT (40") AND THE EXTRA BAR METHOD APPLY ONLY TO LAPS FALLING WITHIN AN AREA OF 10' BEYOND THE CONSTRUCTION JOINT.
  7. CONCRETE FOR LUG ANCHORS SHALL BE POURED AGAINST COMPACTED SUBGRADE. CONCRETE FOR LUGS AND ANCHOR SLAB MAY BE POURED MONOLITHICALLY OR POURED USING RAISED KEY CONSTRUCTION JOINT METHOD. ADEQUATE CONSOLIDATION OF CONCRETE IN LUGS WILL BE OBTAINED WITHOUT DISPLACING LONGITUDINAL CONTINUOUS STEEL, BY THE USE OF INTERNAL VIBRATION. WHEN LESS THAN FULL WIDTH LUG AND PAVEMENT SLAB IS PLACED, THE #5 TRANSVERSE STEEL IN THE LUGS SHALL BE EXTENDED, LAPPED AND SPLICED AT LEAST 25 DIAMETERS.
  8. LONGITUDINAL STEEL TO CONTINUE THROUGH JOINT. EXTRA # 6 BARS 20' LONG SHALL BE SPACED AT 13 1/2" C-C.
  9. CONCRETE SHOULD BE ADEQUATELY VIBRATED UNDER BEAM FLANGE TO ELIMINATE HONEYCOMBS.
  10. IN CONDITIONS OF SOFT CLAY UNDERLYING SOILS (AASHTO SOIL CLASSIFICATION OF GROUP A-4, A-5, A-6, OR A-7) INCLUSIVE OF SUBGROUPS (PER AASHTO MATERIALS SPECIFICATIONS M 145), AN ANCHOR SLAB TYPE I UTILIZING 5 ANCHOR LUGS (ANCHOR SLAB LENGTH = 85') OR AN ANCHOR SLAB TYPE II SHALL BE USED. REINFORCEMENT STEEL SIZE AND SPACING WILL BE THE SAME AS THE CONTINUOUS CONCRETE PAVEMENT.  
  
IN CONDITIONS OF GRANULAR UNDERLYING SOILS ONLY (AASHTO SOIL CLASSIFICATION OF GROUP A-1, A-2, OR A-3) INCLUSIVE OF SUBGROUPS (PER AASHTO MATERIALS SPECIFICATIONS M 145), AN ANCHOR SLAB TYPE I UTILIZING 3 ANCHOR LUGS (ANCHOR SLAB LENGTH = 55') OR AN ANCHOR SLAB TYPE II MAY BE USED. REINFORCEMENT STEEL SIZE AND SPACING WILL BE THE SAME AS THE CONTINUOUS CONCRETE PAVEMENT.
  11. WELD STEEL END PLATE TO BOTH ENDS OF WF BEAM TO SEAL ENDS. WELD SHEAR CONNECTORS TO WEB AND FLANGE OF WF BEAM.
  12. 2 INCH MINIMUM CONCRETE COVER FOR STEEL IN SUB-SLABS.
  13. WIDE FLANGE BEAM TO BE TREATED WITH CORROSION INHIBITOR PER SECTION 407 OF THE ROAD AND BRIDGE SPECIFICATIONS.
  14. ALL REINFORCED BARS SHALL BE GRADE 60 STEEL.
  15. THE USE OF TUBE FEEDING TO PLACE REINFORCEMENT IN PLASTIC CONCRETE WILL NOT BE ALLOWED.

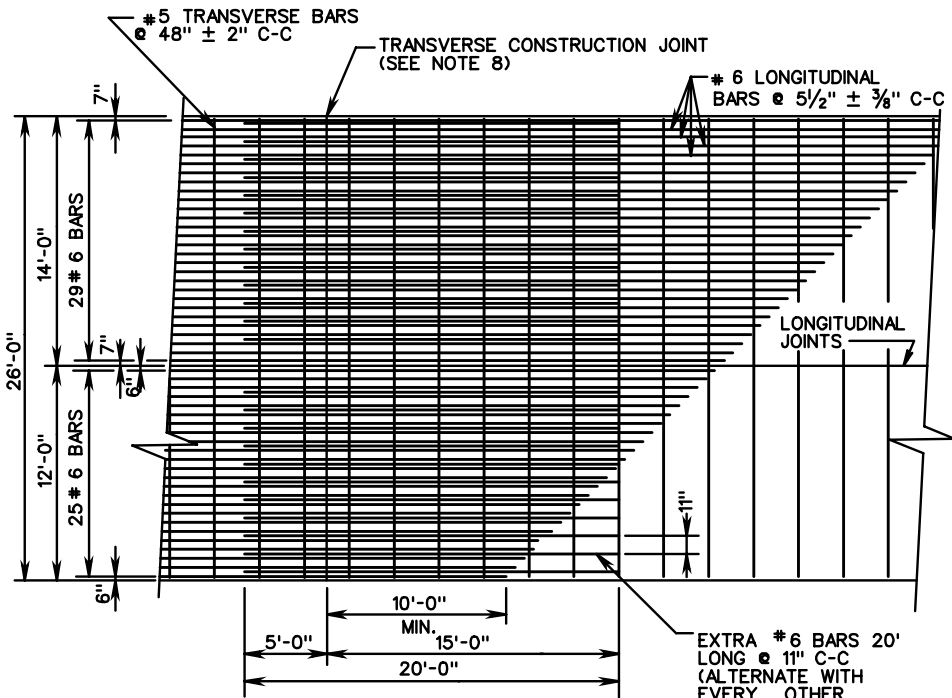

**PLAN VIEW  
LEAVE OUT JOINT  
STEEL BAR REINFORCEMENT ONLY**

|                            |
|----------------------------|
| SPECIFICATION<br>REFERENCE |
| 316                        |

**11" THICK CONTINUOUSLY REINFORCED CONC. PAVE.  
(14 FOOT TRAVEL LANE)**

VIRGINIA DEPARTMENT OF TRANSPORTATION

|  |              |
|--|--------------|
| <b>VDOT</b><br>ROAD AND BRIDGE STANDARDS |              |
| REVISION DATE                            | SHEET 3 OF 3 |
| 301.21                                   |              |

PR-8

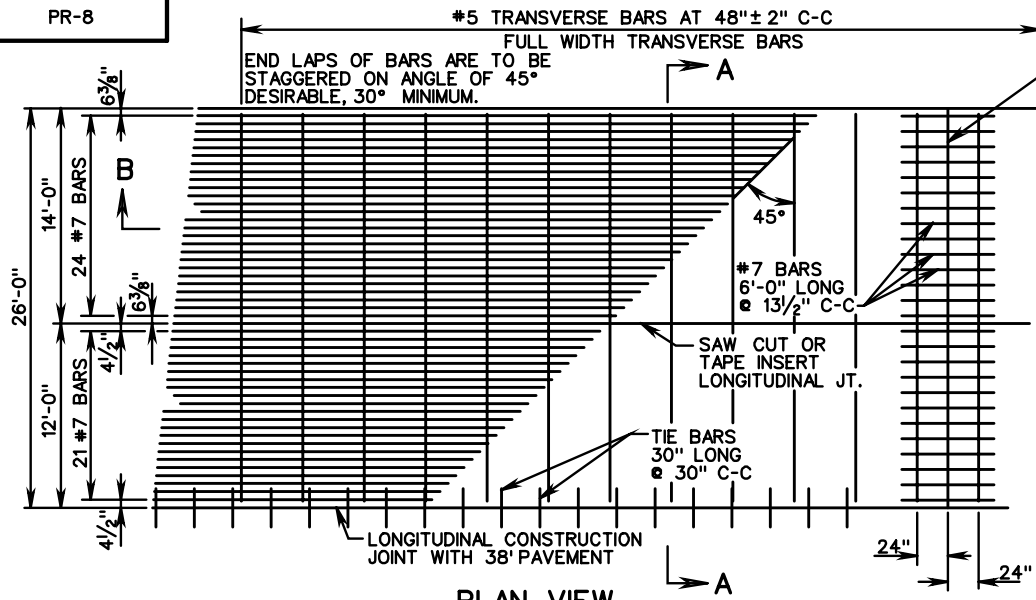

PLAN VIEW CONTINUOUSLY REINFORCED CONCRETE PAVEMENT

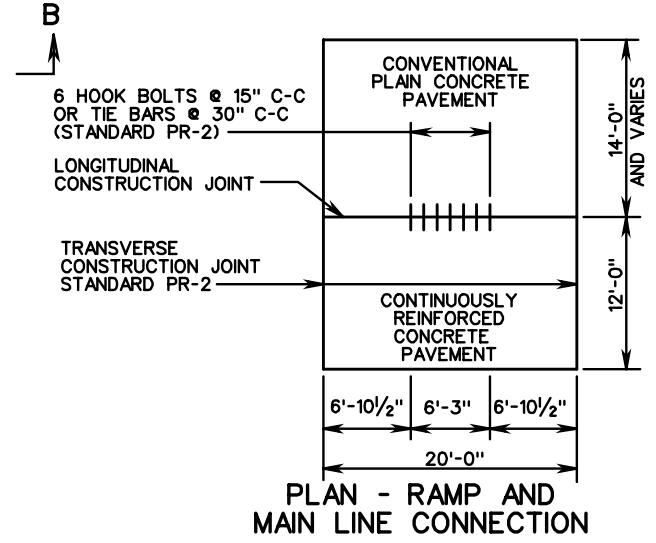

PLAN - RAMP AND MAIN LINE CONNECTION

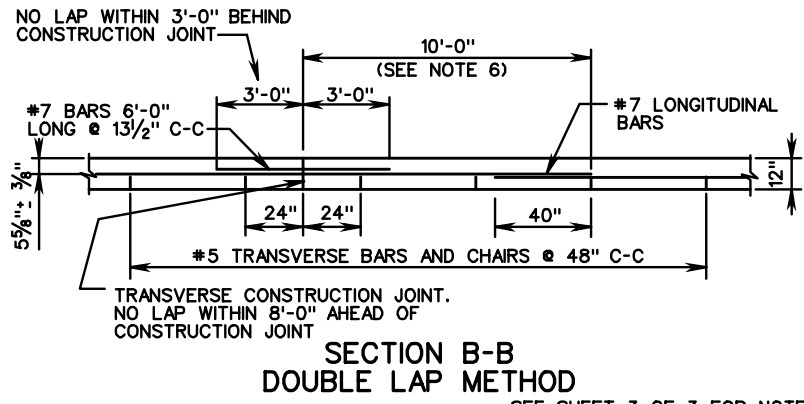
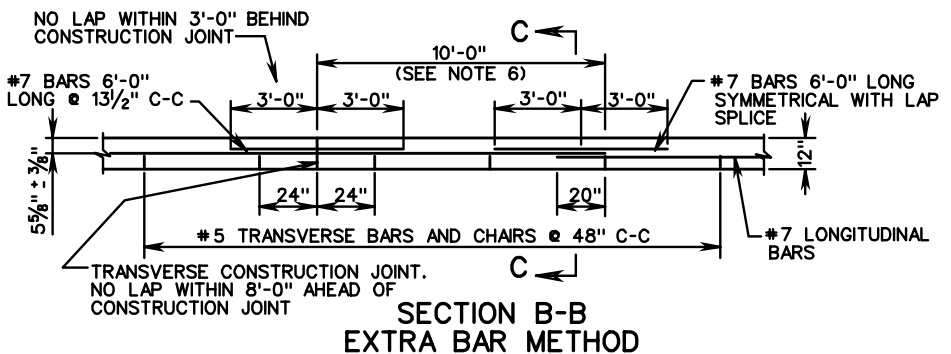
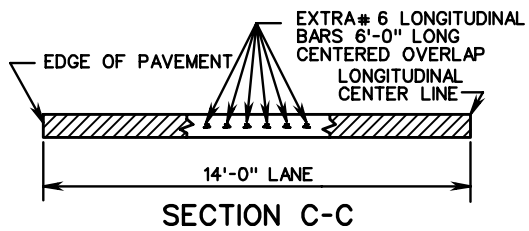
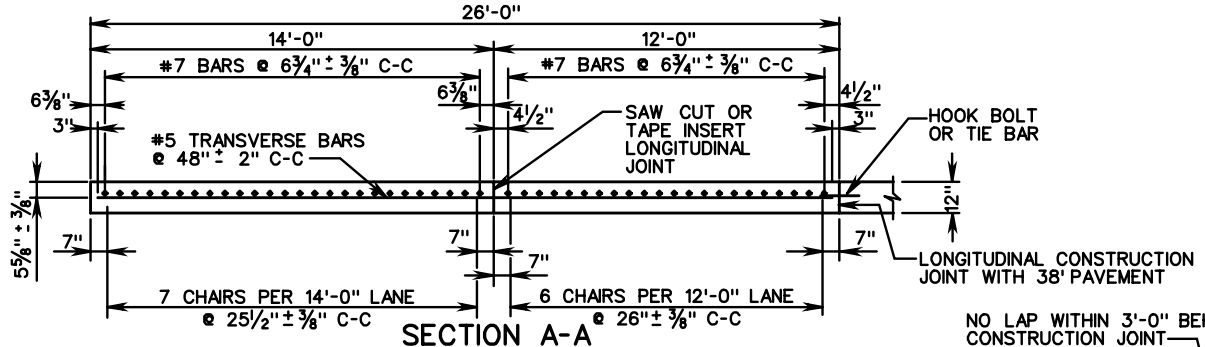

SEE SHEET 3 OF 3 FOR NOTES

|                           |               |
|---------------------------|---------------|
| <b>VDOT</b>               |               |
| ROAD AND BRIDGE STANDARDS |               |
| SHEET 1 OF 3              | REVISION DATE |
| 301.22                    |               |

**12" THICK CONTINUOUSLY REINFORCED CONC. PAVE.**  
(14' TRAVEL LANE)

VIRGINIA DEPARTMENT OF TRANSPORTATION

|                            |
|----------------------------|
| SPECIFICATION<br>REFERENCE |
| 316                        |



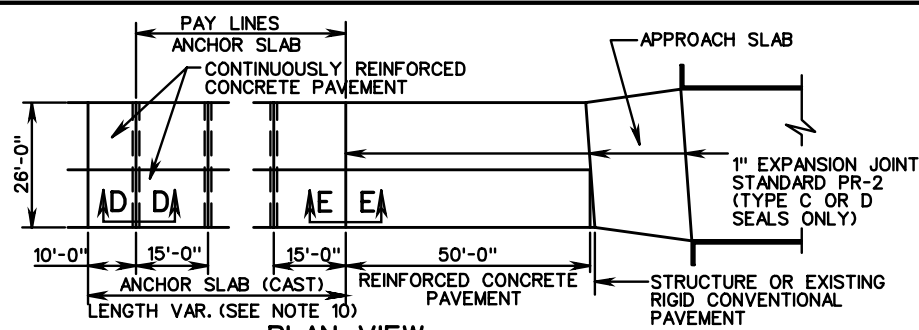

PLAN VIEW  
ANCHOR SLAB TYPE I

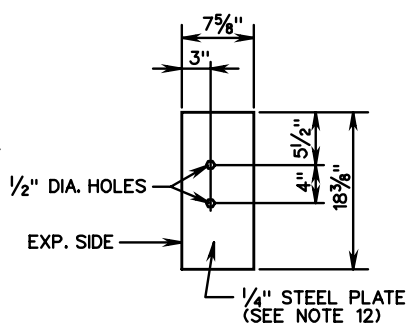

ANCHOR SLAB TYPE II  
END PLATE DETAIL

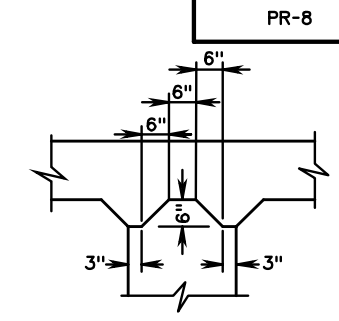

DETAIL A  
RAISED KEY  
CONSTRUCTION JOINT

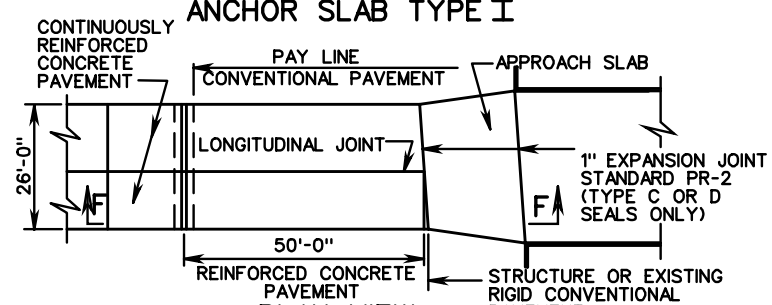

PLAN VIEW  
ANCHOR SLAB TYPE II

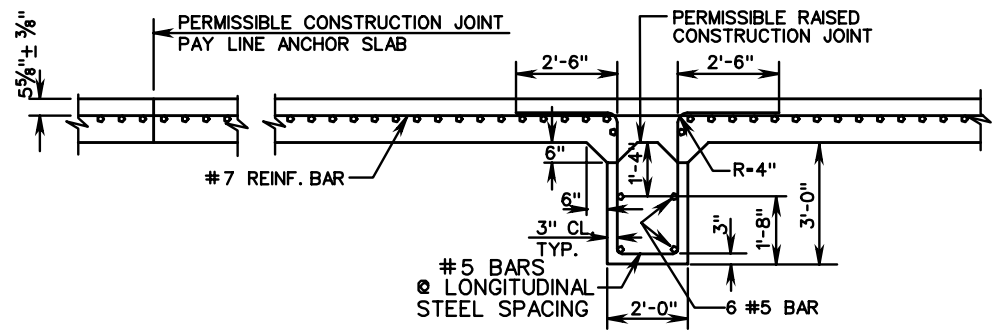

SECTION D-D

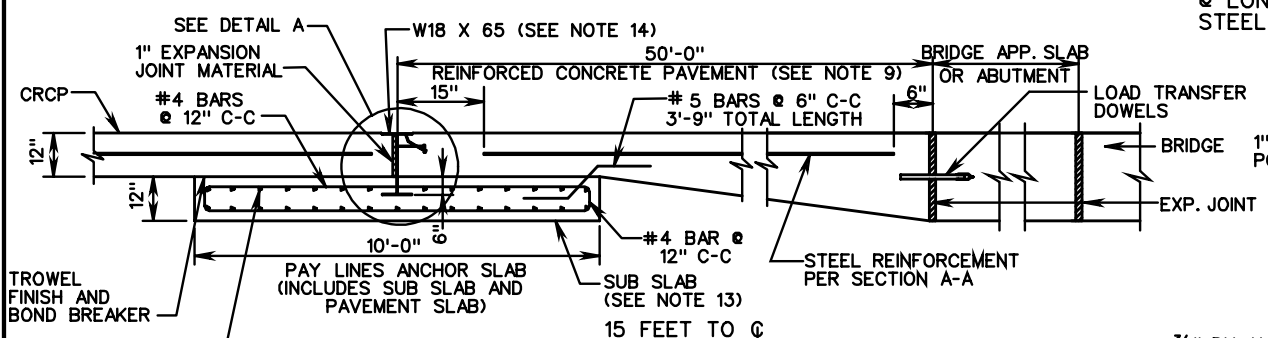

SECTION F-F  
ANCHOR SLAB TYPE II  
(SEE NOTE 11)

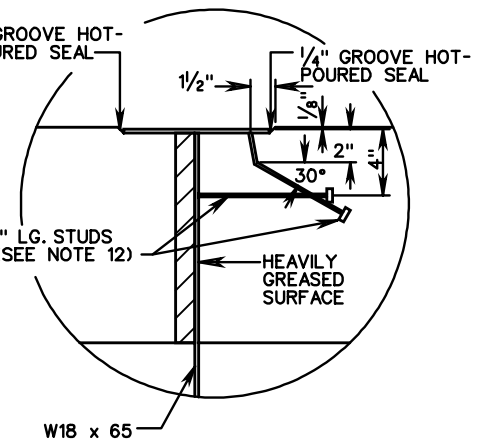

DETAIL A

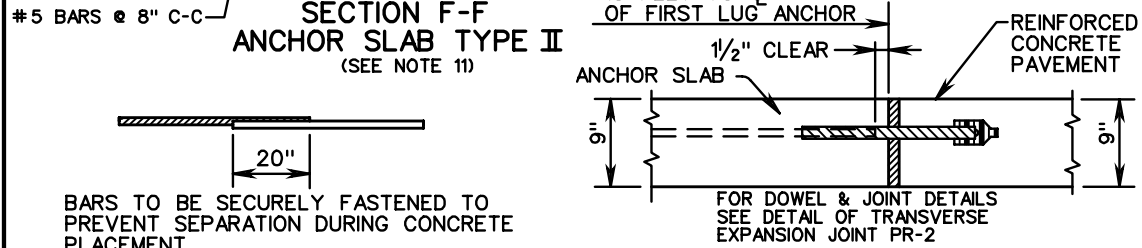

SECTION E-E  
ANCHOR SLAB TYPE I

TROWEL FINISH AND BOND BREAKER  
# 5 BARS @ 8" C-C  
SEE DETAIL A  
W18 X 65 (SEE NOTE 14)  
1" EXPANSION JOINT MATERIAL  
# 4 BARS @ 12" C-C  
12" CRCP  
12" PAY LINES ANCHOR SLAB (INCLUDES SUB SLAB AND PAVEMENT SLAB)  
SUB SLAB (SEE NOTE 13)  
15 FEET TO C OF FIRST LUG ANCHOR  
ANCHOR SLAB  
1/2" CLEAR  
FOR DOWEL & JOINT DETAILS SEE DETAIL OF TRANSVERSE EXPANSION JOINT PR-2

TYPICAL  
LONGITUDINAL LAP

SPECIFICATION REFERENCE

316

12" THICK CONTINUOUSLY REINFORCED CONC PAVE.  
(14' TRAVEL LANE)

VIRGINIA DEPARTMENT OF TRANSPORTATION

SEE SHEET 3 OF 3 FOR NOTES

VDOT

ROAD AND BRIDGE STANDARDS

REVISION DATE

SHEET 2 OF 3

301.23

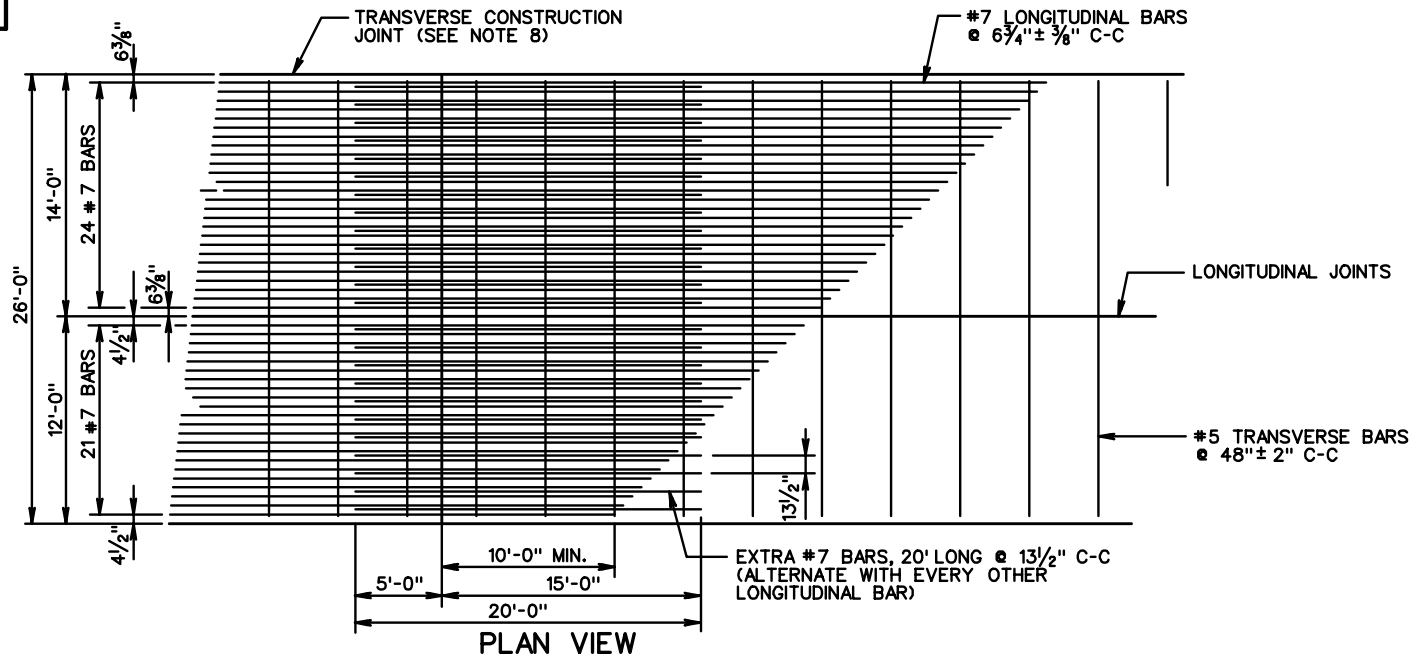

### LEAVE OUT JOINT STEEL BAR REINFORCEMENT ONLY

#### NOTES:

- HOOB BOLTS OR TIE BARS ARE TO BE PLACED IN THE SAME HORIZONTAL PLANE AS #5 TRANSVERSE BARS. WHERE NECESSARY, ADJUST THE LOCATION OF THE HOOB BOLTS OR TIE BARS TO A 2 1/2" MIN. CLEARANCE BETWEEN HOOB BOLTS OR TIE BARS AND TRANSVERSE BARS.
- TRANSVERSE CONSTRUCTION JOINT BARS ARE TO BE PLACED IN THE SAME HORIZONTAL PLANE AS THE #7 LONGITUDINAL BARS.
- #7 LONGITUDINAL BARS ARE TO BE LAPPED AND TIED IN THE SAME HORIZONTAL PLANE.
- FOR THE 38 FOOT WIDTH PAVEMENT USE SINGLE 12 FOOT LANES WITH TWO LONGITUDINAL CONSTRUCTION JOINTS OR 12 FOOT AND 14 FOOT LANES WITH ONE LONGITUDINAL CONSTRUCTION JOINT AND ONE SAW CUT OR TAPE INSERT LONGITUDINAL JOINT. TRANSVERSE BARS SHALL NOT EXTEND THROUGH LONGITUDINAL CONSTRUCTION JOINTS, BUT SHALL EXTEND FULL LENGTH (25'-6") FOR SAW CUT OR TAPE INSERT LONGITUDINAL JOINT.
- SMOOTH SURFACE TO BE STEEL TROWELED 8" FROM EDGE OF PAVEMENT EVERY 500 FT. AND THE STATION NUMBER STAMPED INTO IT AS SHOWN BELOW. THE DATE IS TO BE SHOWN IN A SIMILAR MANNER AT THE BEGINNING OF EACH DAYS POUR. BOTH OUTSIDE EDGES OF DIVIDED HIGHWAY ARE TO BE STAMPED. ONE EDGE OF UNDIVIDED HIGHWAY WHERE FEASIBLE (TRAVEL LANE).
 

255

↓
- DOUBLE LAP REQUIREMENT (40") AND THE EXTRA BAR METHOD APPLY ONLY TO LAPS FALLING WITHIN AN AREA OF 10' BEYOND THE CONSTRUCTION JOINT.
- CONCRETE FOR LUG ANCHORS SHALL BE POURED AGAINST COMPACTED SUBGRADE. CONCRETE FOR LUGS AND ANCHOR SLAB MAY BE POURED MONOLITHICALLY OR USING RAISED KEY CONSTRUCTION JOINT METHOD. ADEQUATE CONSOLIDATION OF CONCRETE IN LUGS WILL BE OBTAINED WITHOUT DISPLACING LONGITUDINAL CONTINUOUS STEEL, BY THE USE OF INTERNAL VIBRATION. WHEN LESS THAN FULL WIDTH LUG AND PAVEMENT SLAB IS PLACED, THE #5 TRANSVERSE STEEL IN THE LUGS SHALL BE EXTENDED, LAPPED AND SPLICED AT LEAST 25 DIAMETERS.
- LONGITUDINAL STEEL TO CONTINUE THROUGH JOINT. EXTRA # 6 BARS 20' LONG SHALL BE SPACED AT 13 1/2" C-C.
- CONCRETE SHOULD BE ADEQUATELY VIBRATED UNDER BEAM FLANGE TO ELIMINATE HONEYCOMBS.
- IN CONDITIONS OF SOFT CLAY UNDERLYING SOILS (AASHTO SOIL CLASSIFICATION OF GROUP A-4, A-5, A-6, OR A-7) INCLUSIVE OF SUBGROUPS (PER AASHTO MATERIALS SPECIFICATIONS M 145), AN ANCHOR SLAB TYPE I UTILIZING 5 ANCHOR LUGS (ANCHOR SLAB LENGTH = 85') OR AN ANCHOR SLAB TYPE II SHALL BE USED. REINFORCEMENT STEEL SIZE AND SPACING WILL BE THE SAME AS THE CONTINUOUS CONCRETE PAVEMENT.
- IN CONDITIONS OF GRANULAR UNDERLYING SOILS ONLY (AASHTO SOIL CLASSIFICATION OF GROUP A-1, A-2, OR A-3) INCLUSIVE OF SUBGROUPS (PER AASHTO MATERIALS SPECIFICATIONS M 145), AN ANCHOR SLAB TYPE I UTILIZING 3 ANCHOR LUGS (ANCHOR SLAB LENGTH = 55') OR AN ANCHOR SLAB TYPE II MAY BE USED. REINFORCEMENT STEEL SIZE AND SPACING WILL BE THE SAME AS THE CONTINUOUS CONCRETE PAVEMENT.
- WELD STEEL END PLATE TO BOTH ENDS OF WF BEAM TO SEAL ENDS. WELD SHEAR CONNECTORS TO WEB AND FLANGE OF WF BEAM.
- 2 INCH MINIMUM CONCRETE COVER FOR STEEL IN SUB-SLABS.
- WIDE FLANGE BEAM TO BE TREATED WITH CORROSION INHIBITOR PER SECTION 407 OF THE ROAD AND BRIDGE SPECIFICATIONS.
- ALL REINFORCED BARS SHALL BE GRADE 60 STEEL.
- THE USE OF TUBE FEEDING TO PLACE REINFORCEMENT IN PLASTIC CONCRETE WILL NOT BE ALLOWED.

VDOT

ROAD AND BRIDGE STANDARDS

## 12" THICK CONTINUOUSLY REINFORCED CONC. PAVE. (14' TRAVEL LANE)

SPECIFICATION  
REFERENCE

SHEET 3 OF 3

REVISION DATE

301.24

VIRGINIA DEPARTMENT OF TRANSPORTATION

316

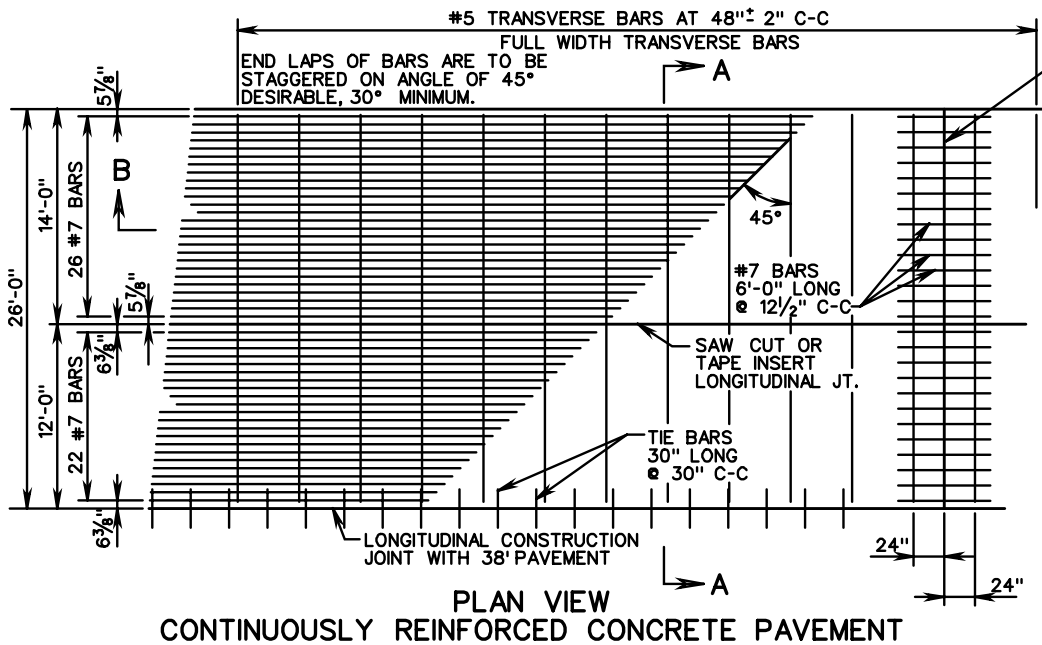

TRANSVERSE CONSTRUCTION JOINT. LONGITUDINAL STEEL TO CONTINUE THROUGH JOINT

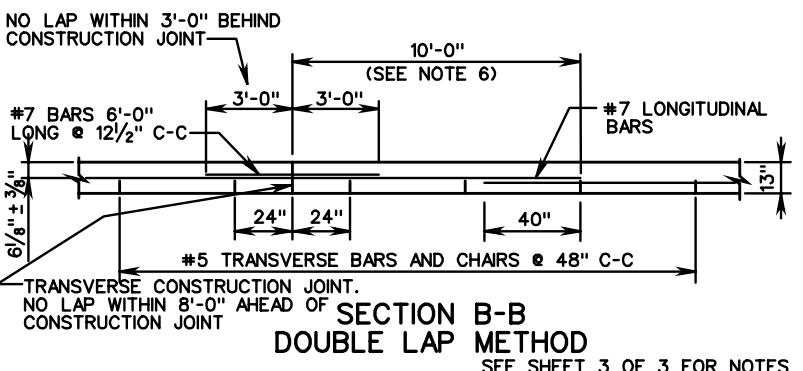
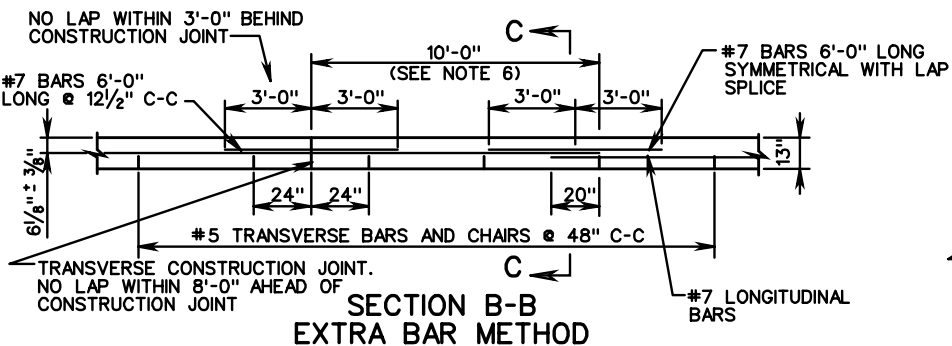
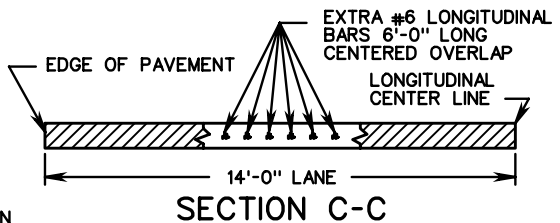
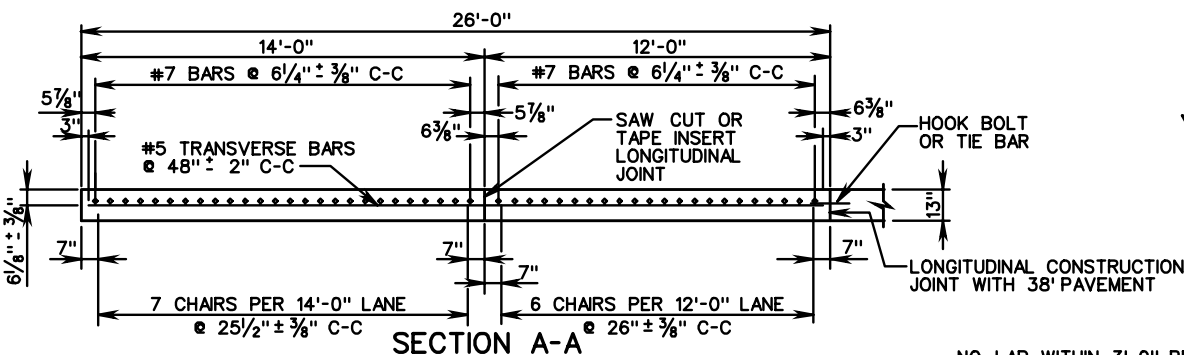
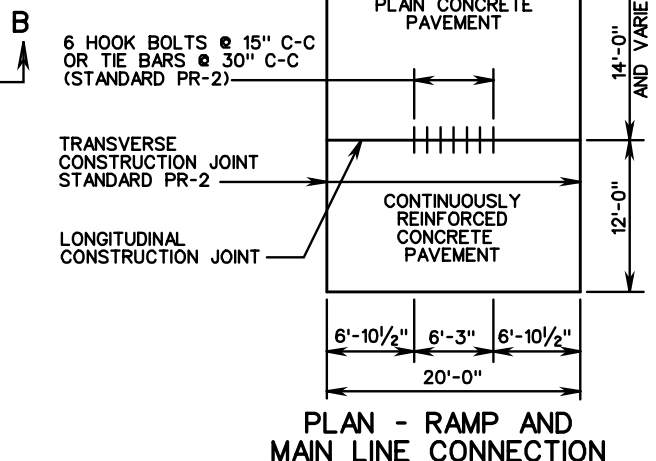

SEE SHEET 3 OF 3 FOR NOTES

|                         |
|-------------------------|
| SPECIFICATION REFERENCE |
| 316                     |

**13" THICK CONTINUOUSLY REINFORCED CONC. PAVE.**  
(14' TRAVEL LANE)  
VIRGINIA DEPARTMENT OF TRANSPORTATION

|                                   |              |
|-----------------------------------|--------------|
| VDOT<br>ROAD AND BRIDGE STANDARDS |              |
| REVISION DATE                     | SHEET 1 OF 3 |
| 301.25                            |              |

PR-9

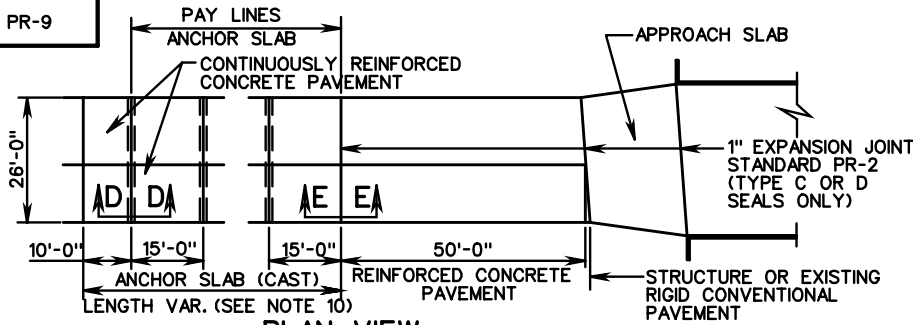

PLAN VIEW  
ANCHOR SLAB TYPE T

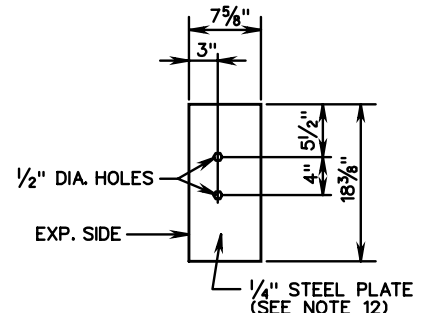

ANCHOR SLAB TYPE II  
END PLATE DETAIL

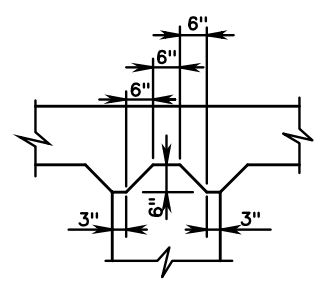

DETAIL A  
RAISED KEY  
CONSTRUCTION JOINT

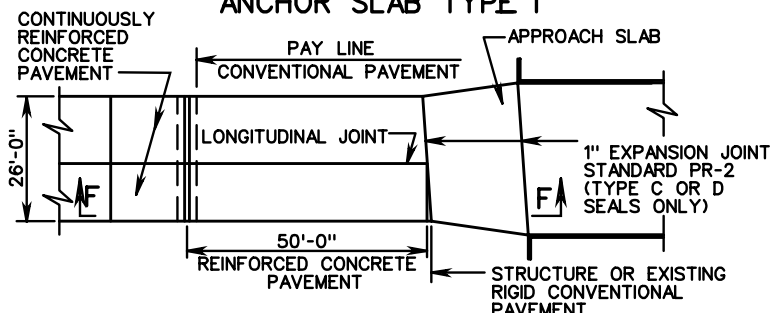

PLAN VIEW  
ANCHOR SLAB TYPE II

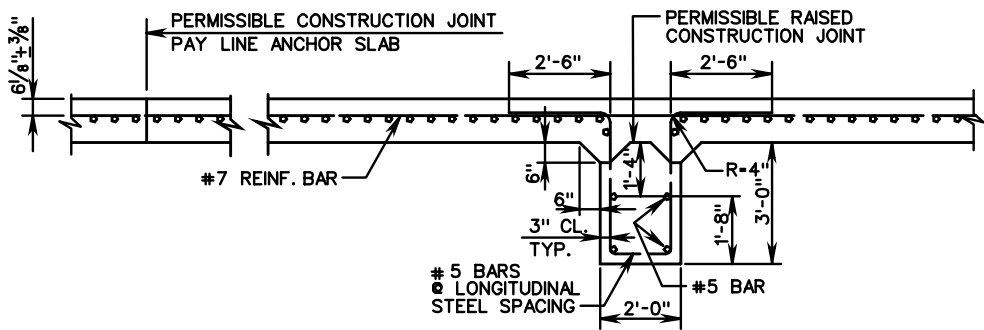

SECTION D-D

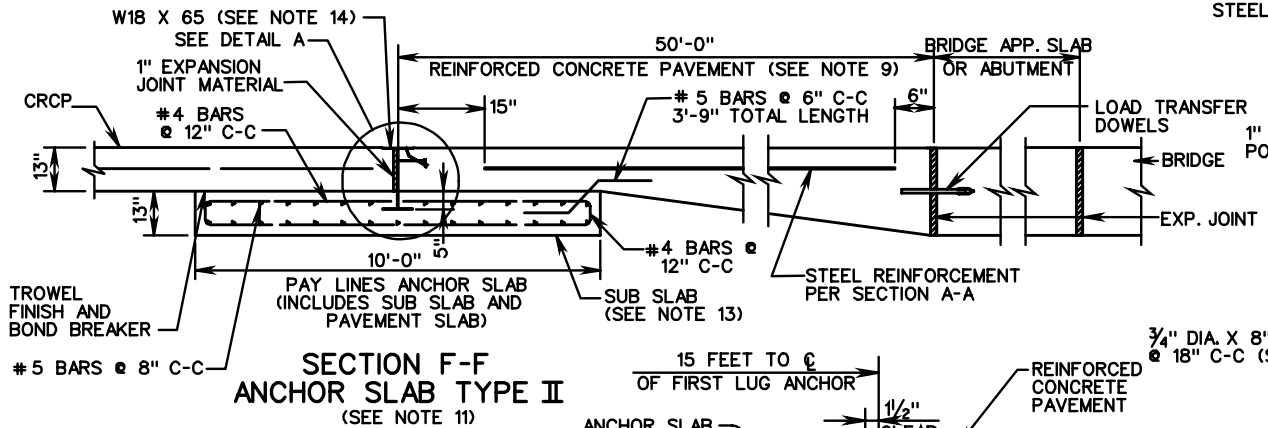

SECTION F-F  
ANCHOR SLAB TYPE II  
(SEE NOTE 11)

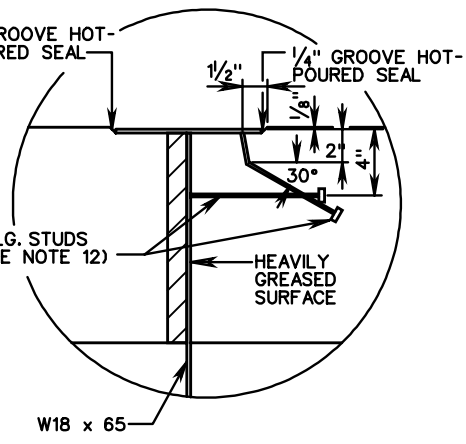

DETAIL A

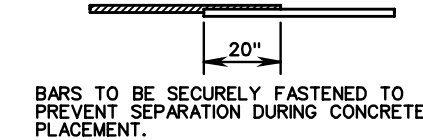

TYPICAL  
LONGITUDINAL LAP

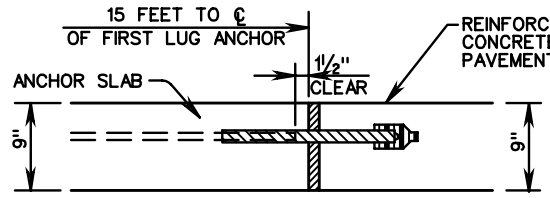

SECTION E-E  
ANCHOR SLAB TYPE I

FOR DOWEL & JOINT DETAILS SEE DETAIL OF TRANSVERSE EXPANSION JOINT PR-2

SEE SHEET 3 OF 3 FOR NOTES

|                                   |               |
|-----------------------------------|---------------|
| VDOT<br>ROAD AND BRIDGE STANDARDS |               |
| SHEET 2 OF 3                      | REVISION DATE |
| 301.26                            |               |

13" THICK CONTINUOUSLY REINFORCED CONC. PAVE.  
(14' TRAVEL LANE)

|                            |
|----------------------------|
| SPECIFICATION<br>REFERENCE |
| 316                        |

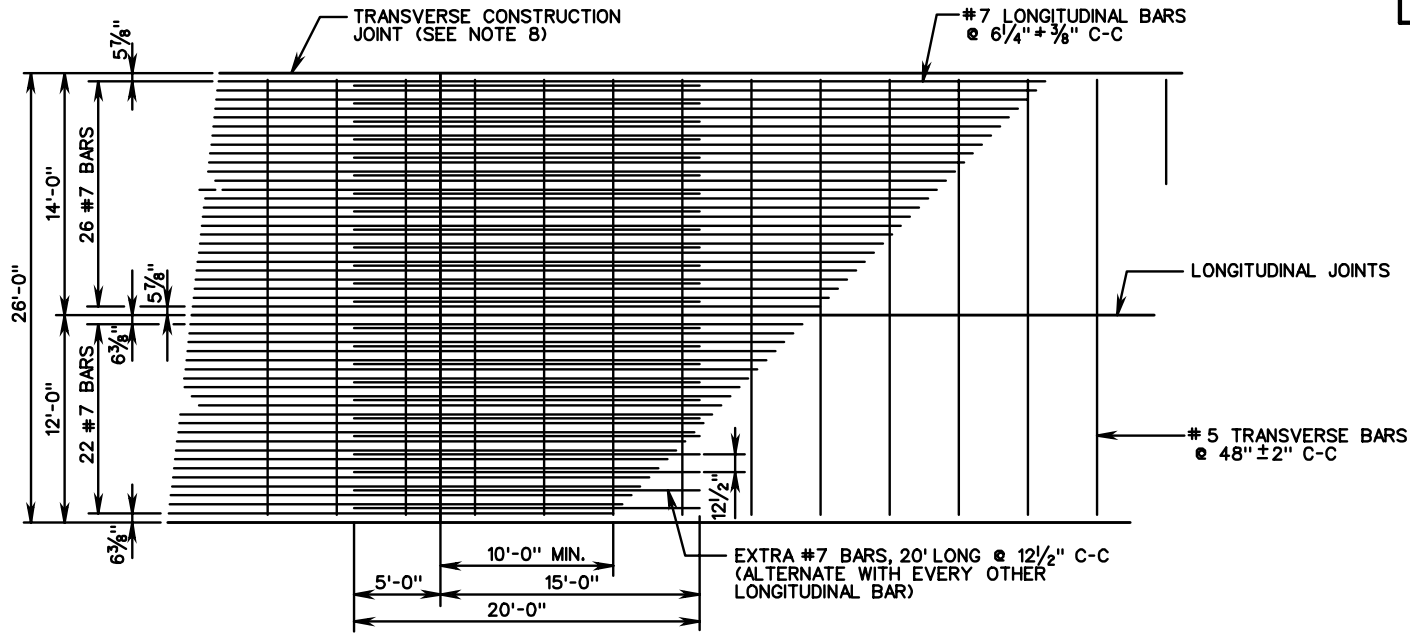

**PLAN VIEW  
LEAVE OUT JOINT STEEL BAR REINFORCEMENT ONLY**

**NOTES:**

1. HOOK BOLTS OR TIE BARS ARE TO BE PLACED IN THE SAME HORIZONTAL PLANE AS #5 TRANSVERSE BARS. WHERE NECESSARY, ADJUST THE LOCATION OF THE HOOK BOLTS OR TIE BARS TO A 2 1/2" MIN. CLEARANCE BETWEEN HOOK BOLTS OR TIE BARS AND TRANSVERSE BARS.
2. TRANSVERSE CONSTRUCTION JOINT BARS ARE TO BE PLACED IN THE SAME HORIZONTAL PLANE AS THE #7 LONGITUDINAL BARS.
3. #7 LONGITUDINAL BARS ARE TO BE LAPPED AND TIED IN THE SAME HORIZONTAL PLANE.
4. FOR THE 38 FOOT WIDTH PAVEMENT USE SINGLE 12 FOOT LANES WITH TWO LONGITUDINAL CONSTRUCTION JOINTS OR 12 FOOT AND 14 FOOT LANES WITH ONE LONGITUDINAL CONSTRUCTION JOINT AND ONE SAW CUT OR TAPE INSERT LONGITUDINAL JOINT. TRANSVERSE BARS SHALL NOT EXTEND THROUGH LONGITUDINAL CONSTRUCTION JOINTS, BUT SHALL EXTEND FULL LENGTH (25'-6") FOR SAW CUT OR TAPE INSERT LONGITUDINAL JOINT.
5. SMOOTH SURFACE TO BE STEEL TROWELED 8" FROM EDGE OF PAVEMENT EVERY 500 FT. AND THE STATION NUMBER STAMPED INTO IT AS SHOWN BELOW. THE DATE IS TO BE SHOWN IN A SIMILAR MANNER AT THE BEGINNING OF EACH DAYS POUR. BOTH OUTSIDE EDGES OF DIVIDED HIGHWAY ARE TO BE STAMPED. ONE EDGE OF UNDIVIDED HIGHWAY WHERE FEASIBLE (TRAVEL LANE).
 

|     |
|-----|
| 255 |
|-----|
6. DOUBLE LAP REQUIREMENT (40") AND THE EXTRA BAR METHOD APPLY ONLY TO LAPS FALLING WITHIN AN AREA OF 10' BEYOND THE CONSTRUCTION JOINT.
7. CONCRETE FOR LUG ANCHORS SHALL BE POURED AGAINST COMPACTED SUBGRADE. CONCRETE FOR LUGS AND ANCHOR SLAB MAY BE POURED MONOLITHICALLY OR USING RAISED KEY CONSTRUCTION JOINT METHOD. ADEQUATE CONSOLIDATION OF CONCRETE IN LUGS WILL BE OBTAINED WITHOUT DISPLACING LONGITUDINAL CONTINUOUS STEEL, BY THE USE OF INTERNAL VIBRATION. WHEN LESS THAN FULL WIDTH LUG AND PAVEMENT SLAB IS PLACED, THE #5 TRANSVERSE STEEL IN THE LUGS SHALL BE EXTENDED, LAPPED AND SPLICED AT LEAST 25 DIAMETERS.
8. LONGITUDINAL STEEL TO CONTINUE THROUGH JOINT. EXTRA #6 BARS 20' LONG SHALL BE SPACED AT 13 1/2" C-C.
9. CONCRETE SHOULD BE ADEQUATELY VIBRATED UNDER BEAM FLANGE TO ELIMINATE HONEYCOMBS.
10. IN CONDITIONS OF SOFT CLAY UNDERLYING SOILS (AASHTO SOIL CLASSIFICATION OF GROUP A-4, A-5, A-6, OR A-7) INCLUSIVE OF SUBGROUPS (PER AASHTO MATERIALS SPECIFICATIONS M 145), AN ANCHOR SLAB TYPE I UTILIZING 5 ANCHOR LUGS (ANCHOR SLAB LENGTH = 85') OR AN ANCHOR SLAB TYPE II SHALL BE USED. REINFORCEMENT STEEL SIZE AND SPACING WILL BE THE SAME AS THE CONTINUOUS CONCRETE PAVEMENT.  
  
 IN CONDITIONS OF GRANULAR UNDERLYING SOILS ONLY (AASHTO SOIL CLASSIFICATION OF GROUP A-1, A-2, OR A-3) INCLUSIVE OF SUBGROUPS (PER AASHTO MATERIALS SPECIFICATIONS M 145), AN ANCHOR SLAB TYPE I UTILIZING 3 ANCHOR LUGS (ANCHOR SLAB LENGTH = 55') OR AN ANCHOR SLAB TYPE II MAY BE USED. REINFORCEMENT STEEL SIZE AND SPACING WILL BE THE SAME AS THE CONTINUOUS CONCRETE PAVEMENT.
11. WELD STEEL END PLATE TO BOTH ENDS OF WF BEAM TO SEAL ENDS. WELD SHEAR CONNECTORS TO WEB AND FLANGE OF WF BEAM.
12. 2 INCH MINIMUM CONCRETE COVER FOR STEEL IN SUB-SLABS.
13. WIDE FLANGE BEAM TO BE TREATED WITH CORROSION INHIBITOR PER SECTION 407 OF THE ROAD AND BRIDGE SPECIFICATIONS.
14. ALL REINFORCED BARS SHALL BE GRADE 60 STEEL.
15. THE USE OF TUBE FEEDING TO PLACE REINFORCEMENT IN PLASTIC CONCRETE WILL NOT BE ALLOWED.

SPECIFICATION REFERENCE

316

**13" THICK CONTINUOUSLY REINFORCED CONC. PAVE.  
(14' TRAVEL LANE)**

VIRGINIA DEPARTMENT OF TRANSPORTATION

**VDOT**

ROAD AND BRIDGE STANDARDS

REVISION DATE

SHEET 3 OF 3

301.27

THIS PAGE INTENTIONALLY LEFT BLANK



ROAD AND BRIDGE STANDARDS

SHEET 1 OF 1

REVISION DATE

301.28

VIRGINIA DEPARTMENT OF TRANSPORTATION

SPECIFICATION  
REFERENCE

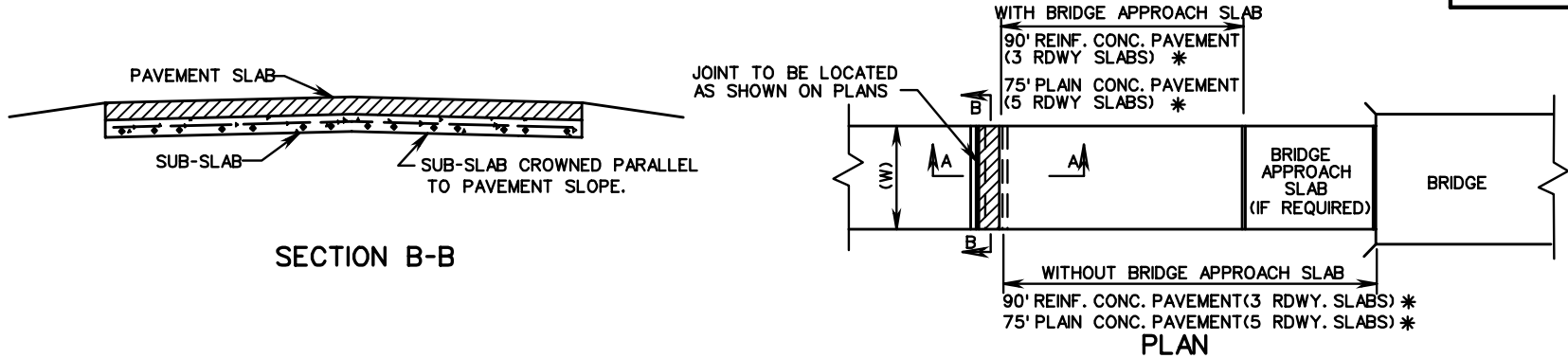

\* DENOTES DESIRABLE VALUES, PAVEMENT TYPE (PLAIN OR REINFORCED) TO BE DETERMINED BY THE MATERIALS DIVISION.

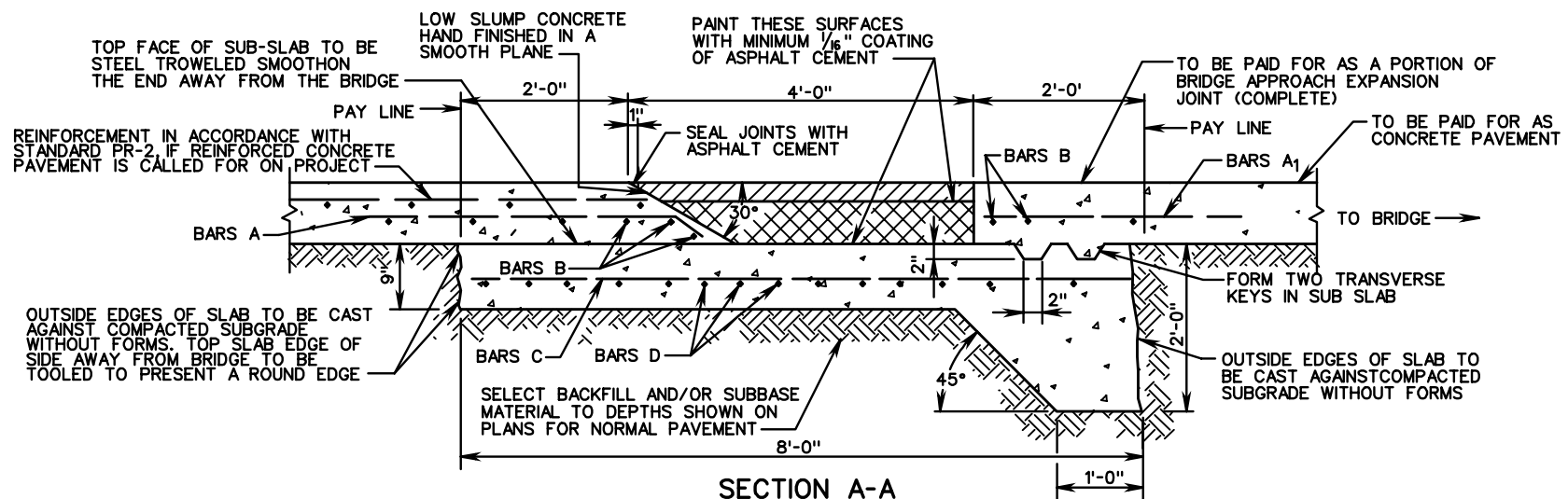

|  | APPROXIMATE QUANTITIES PER YARD OF TRANSVERSE MEASURE |       |
|--|---|-------|
|  | 8"  | 9"    |
| CUBIC YARDS CLASS A3 CONCRETE            | 0.30  | 0.30  |
| REINFORCING STEEL LBS.                   | 33.44   | 33.44 |
| ASPHALT CONCRETE BM-25.0 TONS            | 0.16  | 0.18  |
| TONS ASPHALT CONCRETE CONN. SM-9.5A OR D | 0.06  | 0.06  |
| SQ. YARDS CONCRETE PAVEMENT **           | 0.51  | 0.52  |

\*\* BEVELED PORTION OF PAVEMENT SLAB HAS BEEN CONVERTED TO EQUIVALENT DESIGN DEPTH OF MAIN LINE PAVEMENT.

| SCHEDULE OF REINFORCING STEEL |      |             |        |            |                                    |
|-------------------------------|------|-------------|--------|------------|------------------------------------|
| MARK                          | SIZE | SPACING C-C | LENGTH | NO. REQ'D. | WEIGHT/FT. TRANSVERSE MEASURE LBS. |
| A                             | 5    | 12"         | 4'-0"  | (W)        | 4.172                              |
| A <sub>1</sub>                | 5    | 12"         | 3'-0"  | (W)        | 3.129                              |
| B                             | 5    | 6"          | W-4"   | 5          | 5.215                              |
| C                             | 4    | 6"          | 7'-8"  | (W)(2)     | 10.240                             |
| D                             | 4    | 6"          | W-4"   | 16         | 10.688                             |

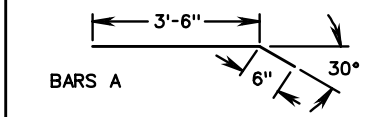

ASPHALT CONCRETE BASE COURSE TYPE BM-25.0  
6" WITH 8" PAVEMENT  
7" WITH 9" PAVEMENT

2" ASPHALT CONCRETE TYPE SM-9.5A OR D

NOTES:  
CONCRETE IN SUBSLAB TO BE CLASS A3.  
BARS A, A<sub>1</sub>, & B TO BE PLACED AS SHOWN WHETHER PLAIN OR REINFORCED CONCRETE PAVEMENT IS USED.  
PORTIONS OF BARS A AND A<sub>1</sub>, WHICH ARE OUTSIDE OF THE INDICATED PAY LINES ARE INCLUDED IN PRICE BID FOR COMPLETE JOINT.

|                         |
|-------------------------|
| SPECIFICATION REFERENCE |
| 316                     |

## BRIDGE APPROACH EXPANSION JOINT (FOR WIDENING OR MAINTENANCE OF EXISTING XJ-1 ONLY)

VIRGINIA DEPARTMENT OF TRANSPORTATION

|  |              |
|--|--------------|
| <b>VDOT</b><br>ROAD AND BRIDGE STANDARDS |              |
| REVISION DATE                            | SHEET 1 OF 2 |
| 302.01                                   |              |

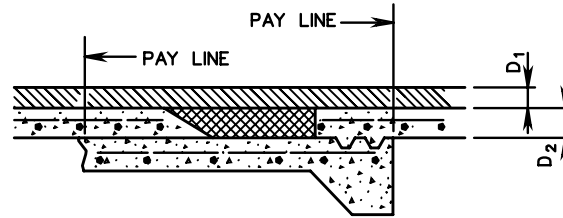

D<sub>1</sub> = DEPTH OF ASPHALT TOP USED ON APPROACHES  
 D<sub>2</sub> = DEPTH OF CONCRETE BASE USED ON APPROACHES

VIEW (A)

USED WITH CONCRETE BASE WITH ASPHALT CONCRETE SURFACE

**NOTE:**

BRIDGE APPROACH EXPANSION JOINT INCLUDING SUB-SLAB IS TO TERMINATE AT EDGE OF THROUGH PAVEMENT.

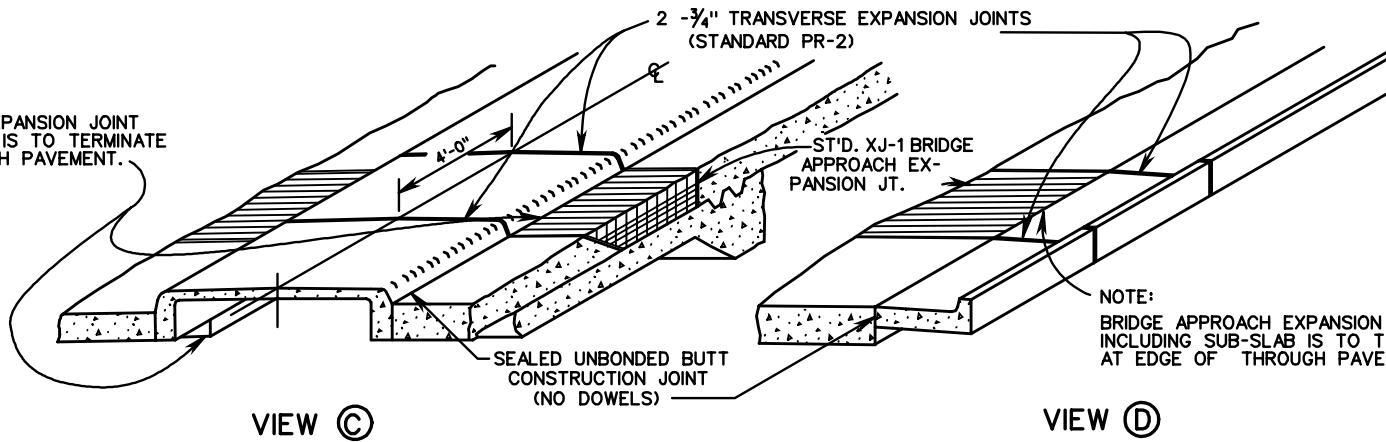

VIEW (C)

USED ADJACENT TO RAISED MEDIAN

VIEW (D)

USED ADJACENT TO CURB OR COMBINATION CURB AND GUTTER

**NOTES:**

ALL CONSTRUCTION FEATURES TO BE IN ACCORDANCE WITH SHEET 1 OF 2.  
 IF CONCRETE PAVEMENT IS USED ADJACENT TO CONCRETE PAVEMENT WITH ASPHALT CONCRETE SURFACE, THE JOINT IS TO CONTINUE ACROSS ENTIRE WIDTH IN ACCORDANCE WITH SHEET 1 OF 2 AND VIEW A.  
 IF CONCRETE PAVEMENT IS USED ADJACENT TO FLEXIBLE PAVEMENT THE JOINT IS TO EXTEND THROUGH RIGID PAVEMENT ONLY.



ROAD AND BRIDGE STANDARDS

SHEET 2 OF 2

REVISION DATE

302.02

**BRIDGE APPROACH EXPANSION JOINT  
 (INSTALLATION CRITERIA)**

VIRGINIA DEPARTMENT OF TRANSPORTATION

SPECIFICATION REFERENCE

316



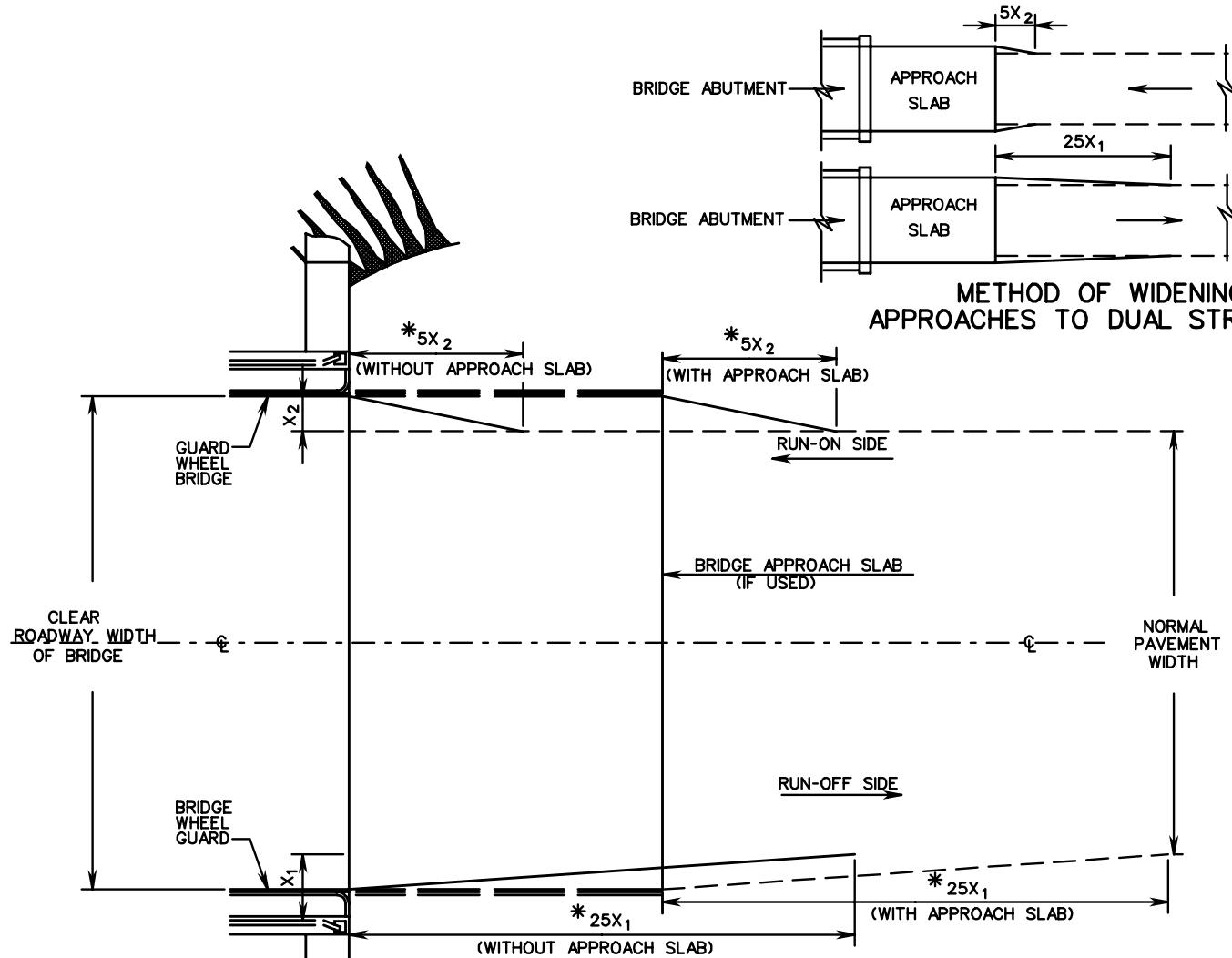

METHOD OF WIDENING APPROACHES TO DUAL STRUCTURES

NOTES:

ON FULL SHOULDER WIDTH BRIDGES, NO WIDENING IS TO BE PROVIDED.

$X_1$  AND  $X_2$  - AMOUNT OF BRIDGE WIDENING PER SIDE (10' MAXIMUM).

\* IF BRIDGE DRAINAGE APRONS ARE REQUIRED THE PAVEMENT WIDENING IS TO BE APPLIED AT THE END OF THE DRAINAGE APRON FARTHEST FROM THE ABUTMENT BACKWALL.

|                         |
|-------------------------|
| SPECIFICATION REFERENCE |
| NONE                    |



METHOD OF WIDENING BRIDGE APPROACH PAVEMENT

VIRGINIA DEPARTMENT OF TRANSPORTATION

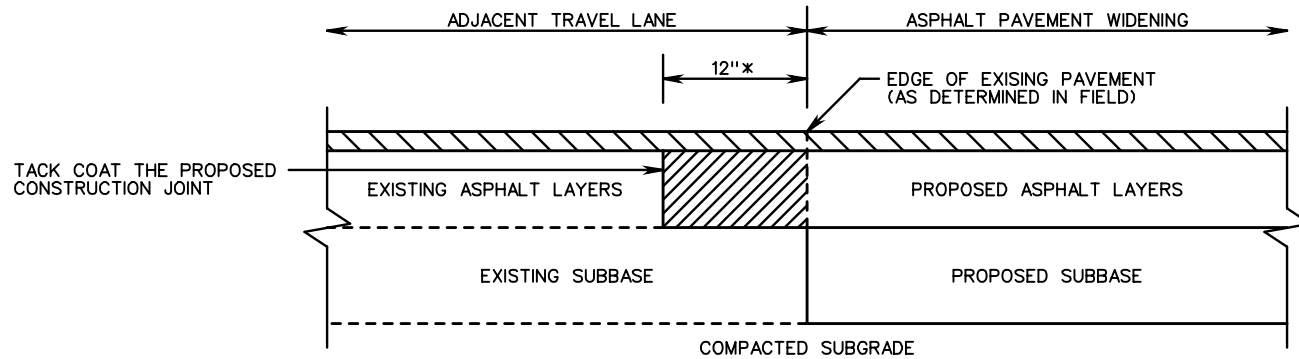
|                                   |              |
|-----------------------------------|--------------|
| VDOT<br>ROAD AND BRIDGE STANDARDS |              |
| REVISION DATE                     | SHEET 1 OF 1 |
|                                   | 303.01       |



**CONSTRUCTION JOINT DETAIL**

-  REMOVE EXISTING ASPHALT LAYERS TO EXISTING SUBBASE AND REPLACE WITH PROPOSED ASPHALT WIDENING LAYERS
-  PROPOSED MINIMUM 1½ INCH THICK ASPHALT SURFACE COURSE (SEE NOTE 5)
- \* MINIMUM 12 INCHES, OR GREATER AS NECESSARY TO ABUT THE FULL THICKNESS OF EXISTING ASPHALT LAYERS AS DETERMINED BY CORES (SEE NOTE 3)

**NOTES:**

1. ASPHALT PAVEMENT WIDENING SHALL HAVE A PAVEMENT DESIGN IN ACCORDANCE WITH CURRENT VDOT PROCEDURES AND BE APPROVED BY THE ENGINEER.
2. THE PAVEMENT DESIGN FOR ASPHALT PAVEMENT WIDENING SHALL MEET OR EXCEED THE DEPTHS AND TYPES OF THE LAYERS OF EXISTING PAVEMENT. SUBSURFACE DRAINAGE OF THE EXISTING AND PROPOSED PAVEMENT SHALL BE ADDRESSED IN THE PAVEMENT DESIGN.
3. A MINIMUM OF THREE CORES SHALL BE TAKEN ALONG THE CENTER OF THE ADJACENT TRAVEL LANE TO DETERMINE THE TYPE AND THICKNESS OF EXISTING PAVEMENT LAYERS. THESE CORES SHALL BE SPACED NO MORE THAN 500 FEET APART.
4. THE ADJACENT TRAVEL LANE SHALL BE MILLED A MINIMUM DEPTH OF 1½ INCHES AND REPLACED WITH AN ASPHALT SURFACE COURSE TO MATCH THE PROPOSED PAVEMENT WIDENING SURFACE COURSE, UNLESS WAIVED BY THE ENGINEER.
5. THE ENGINEER MAY REQUIRE THE MILLING DEPTH OF THE EXISTING PAVEMENT TO BE ADJUSTED TO ACHIEVE AN ACCEPTABLE PAVEMENT CROSS-SLOPE AND EFFECTIVE SURFACE DRAINAGE.
6. EXISTING PAVEMENT MARKINGS AND MARKERS WITHIN THE PROJECT LIMITS SHALL BE RESTORED SUBJECT TO THE APPROVAL OF THE ENGINEER.
7. FINAL TRANSVERSE PAVEMENT TIE-IN SHALL CONFORM TO THE REQUIREMENTS OF SECTION 315.05(c) OF THE SPECIFICATIONS EXCEPT THAT ALL JOINTS AT TIE-IN LOCATIONS SHALL BE TESTED USING A 10 FOOT STRAIGHTEDGE IN ACCORDANCE WITH THE REQUIREMENTS OF SECTION 315.07(q) OF THE SPECIFICATIONS.



ROAD AND BRIDGE STANDARDS

SHEET 1 OF 1

REVISION DATE

303.02

**ASPHALT PAVEMENT WIDENING  
FOR WIDENING SUBJECT TO TRAFFIC**

VIRGINIA DEPARTMENT OF TRANSPORTATION

SPECIFICATION  
REFERENCE

315

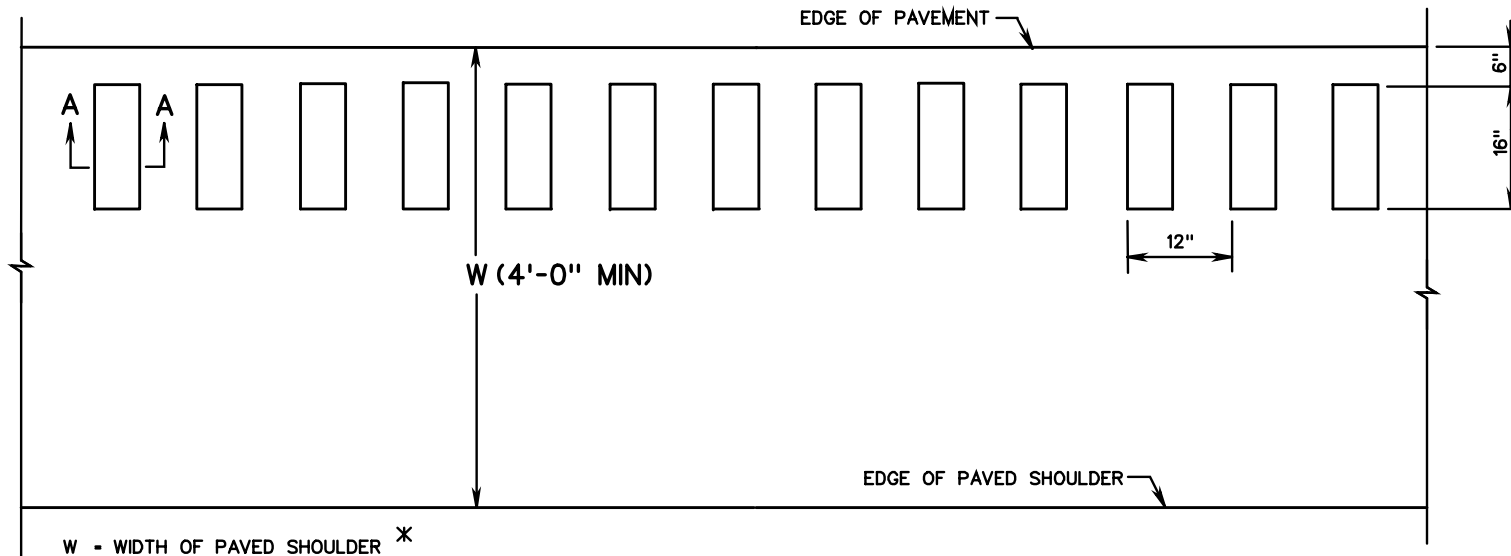

PLAN VIEW

NOTES

RUMBLE STRIPS SHALL BE PLACED CONTINUOUSLY AS DIRECTED BY THE ENGINEER.

RUMBLE STRIPS SHALL NOT BE PLACED WITHIN LIMITS OF BRIDGE DRAINAGE APRONS OR SPECIAL DESIGN SHOULDER SLOT INLETS.

RUMBLE STRIPS SHALL BE PLACED ON MAINLINE SHOULDERS ONLY.

\* WHERE BICYCLES ARE NOT PROHIBITED, THE MINIMUM WIDTH OF THE OUTSIDE PAVED SHOULDER SHALL BE 8 FT.

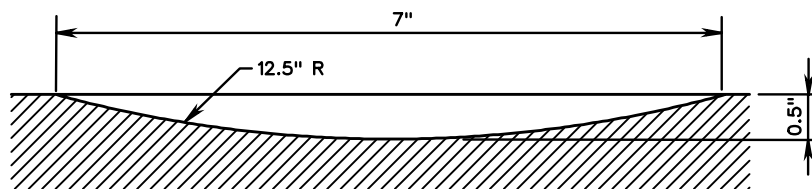

SECTION A-A

SPECIFICATION REFERENCE

310  
315

CONTINUOUS SHOULDER RUMBLE STRIPS

VIRGINIA DEPARTMENT OF TRANSPORTATION

VDOT

ROAD AND BRIDGE STANDARDS

REVISION DATE

SHEET 1 OF 1

304.01

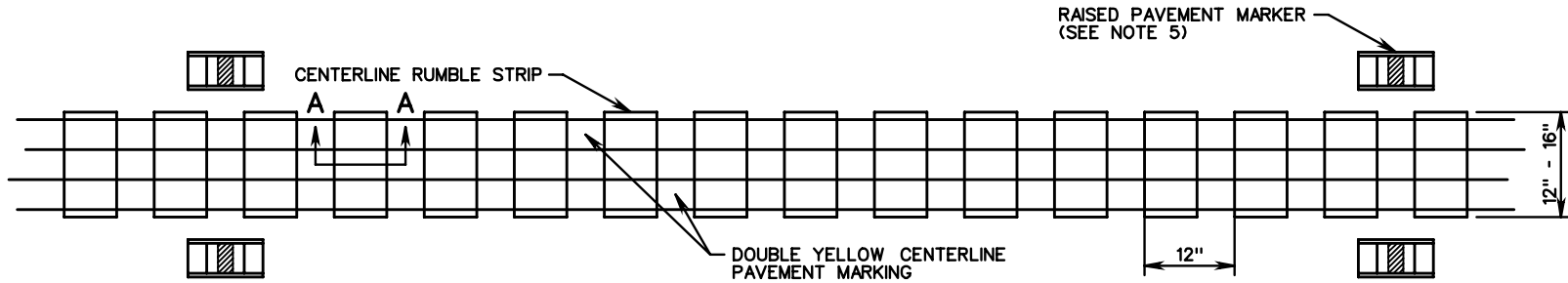

PLAN VIEW

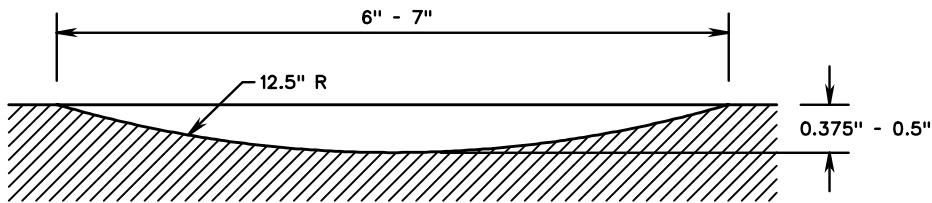

SECTION A-A

NOTES

1. CENTERLINE RUMBLE STRIPS SHALL NOT BE INSTALLED WITHIN THE LIMITS OF BRIDGES.
2. CENTERLINE RUMBLE STRIPS SHALL NOT BE INSTALLED ON SUBDIVISION STREETS OR IN NARROW UNMARKED ROAD SECTIONS WITHOUT PAVEMENT MARKINGS.
3. CENTERLINE RUMBLE STRIPS SHALL NOT BE INSTALLED WITHIN THE LIMITS OF CENTER TWO-WAY TURN LANES.
4. CENTERLINE RUMBLE STRIPS SHALL NOT BE INSTALLED IN PASSING ZONES EXCEPT AS DIRECTED BY THE TRAFFIC ENGINEER. THE DEPTH OF CENTERLINE RUMBLE STRIPS IN PASSING ZONES SHALL BE  $\frac{3}{8}$ ".
5. USE OF RAISED PAVEMENT MARKERS IS OPTIONAL. SEE STANDARD PM-9 FOR DETAILS ON RAISED PAVEMENT MARKER PLACEMENT.



ROAD AND BRIDGE STANDARDS

SHEET 1 OF 1

REVISION DATE

304.02

CENTERLINE RUMBLE STRIPS

VIRGINIA DEPARTMENT OF TRANSPORTATION

SPECIFICATION REFERENCE

TRANSVERSE PAVEMENT TIE-IN

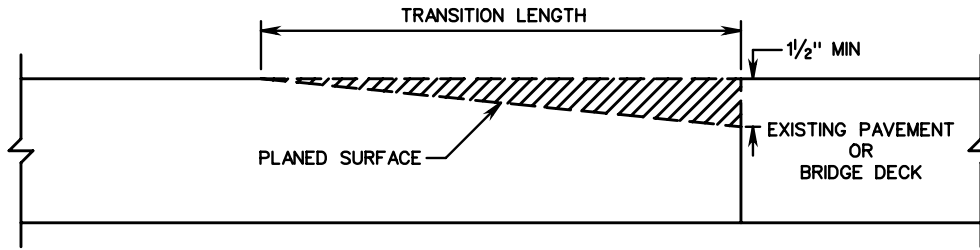

PLANING TRANSITION PAVEMENT DETAIL

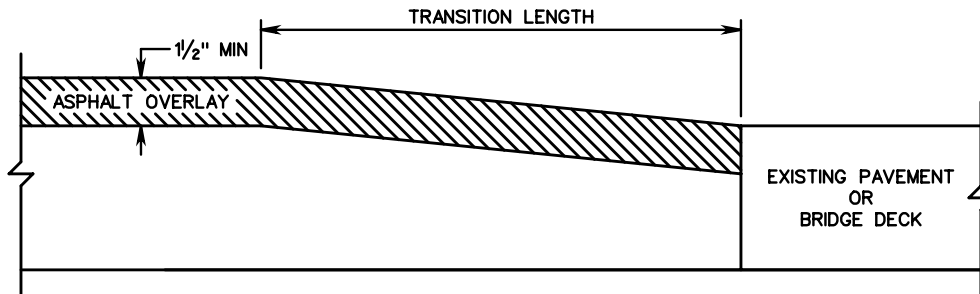

OVERLAYING TRANSITION PAVEMENT DETAIL

NOTES

1. TRANSVERSE PAVEMENT TIE-IN SHALL BE USED TO PROVIDE A SMOOTH TRANSITION BETWEEN NEW PAVEMENT AND EITHER EXISTING PAVEMENT OR AN EXISTING BRIDGE DECK AS SHOWN ON THE PLANS AND DIRECTED BY THE ENGINEER.
2. THE EXISTING PAVEMENT SHALL BE PLANED A MINIMUM DEPTH OF 1/2". THE FULL DEPTH OF PLANING SHALL EQUAL THE DEPTH OF THE ASPHALT OVERLAY.
3. TRANSVERSE PAVEMENT TIE-INS SHALL BE CONSTRUCTED A MINIMUM OF 10 FEET IN LENGTH FOR EVERY INCH OF DEPTH OF PAVEMENT PLANING PERFORMED.
4. TRANSVERSE PAVEMENT TIE-IN SHALL CONFORM TO THE REQUIREMENTS OF SECTION 315.05(c) OF THE SPECIFICATIONS EXCEPT THAT ALL JOINTS AT TIE-IN LOCATIONS SHALL BE TESTED USING A 10 FOOT STRAIGHT EDGE IN ACCORDANCE WITH THE REQUIREMENTS OF SECTION 315.07(d) OF THE SPECIFICATIONS. THE VARIATION FROM THE TESTING EDGE OF THE STRAIGHT EDGE BETWEEN ANY TWO CONTACT POINTS WITH THE PAVEMENT SURFACE SHALL NOT EXCEED 1/4".

TEMPORARY PAVEMENT WEDGE

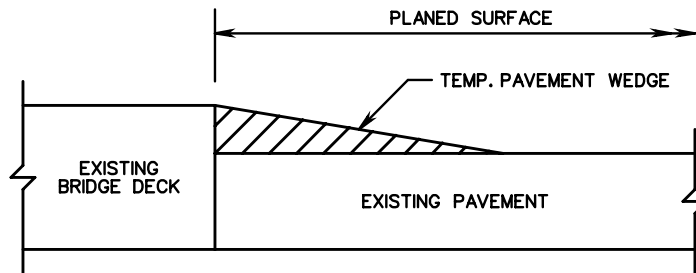

WEDGE DETAIL

NOTES

1. TEMPORARY PAVEMENT WEDGE SHALL BE CONSTRUCTED OF SURFACE MIX ASPHALT A MINIMUM OF 3 FEET IN LENGTH FOR EVERY INCH OF DEPTH OF PAVEMENT MILLING.

SPECIFICATION REFERENCE

210  
315  
515

TRANSVERSE PAVEMENT TIE-IN

VIRGINIA DEPARTMENT OF TRANSPORTATION

VDOT

ROAD AND BRIDGE STANDARDS

REVISION DATE

SHEET 1 OF 1

305.01

THIS PAGE INTENTIONALLY LEFT BLANK



ROAD AND BRIDGE STANDARDS

SHEET 1 OF 1

REVISION DATE

305.02

VIRGINIA DEPARTMENT OF TRANSPORTATION

SPECIFICATION  
REFERENCE