

FE-4

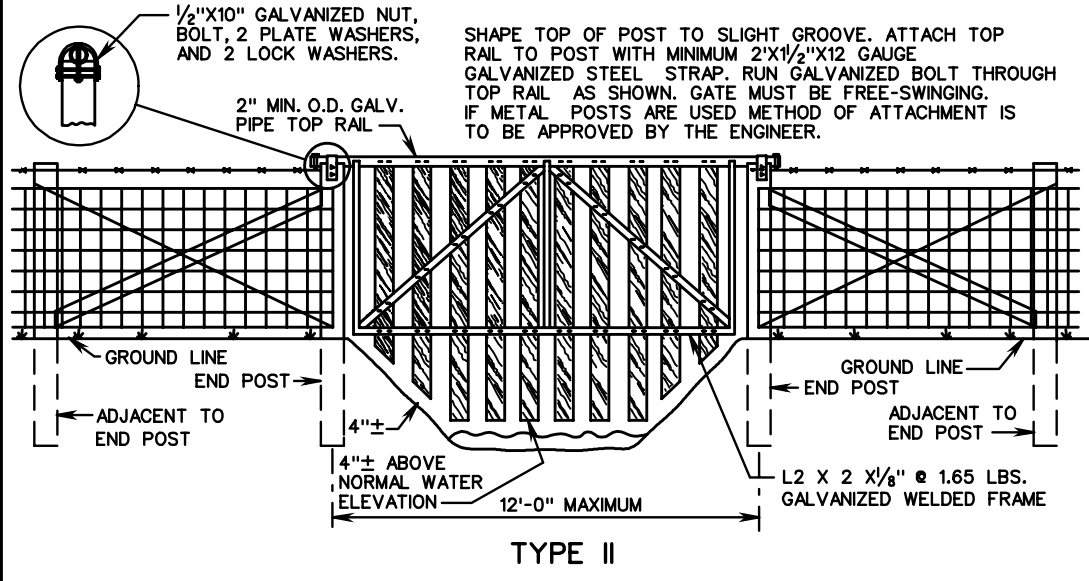

METHOD OF FASTENING FILLER BOARDS TO ANGLE IRON FRAME (TYPE I, TYPE II AND TYPE III)

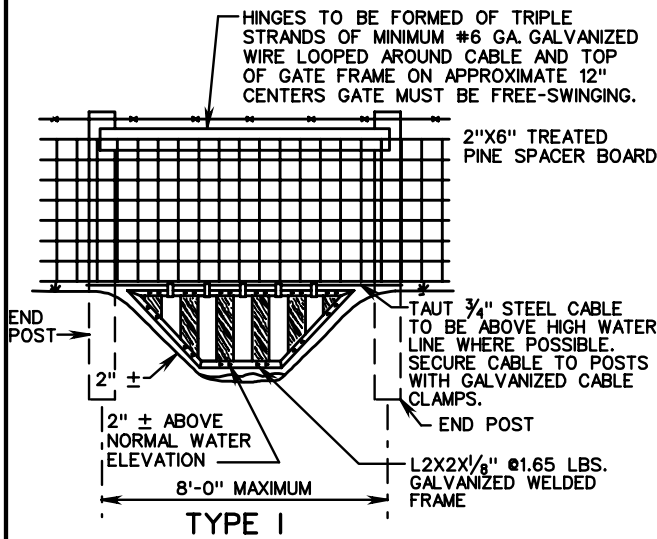
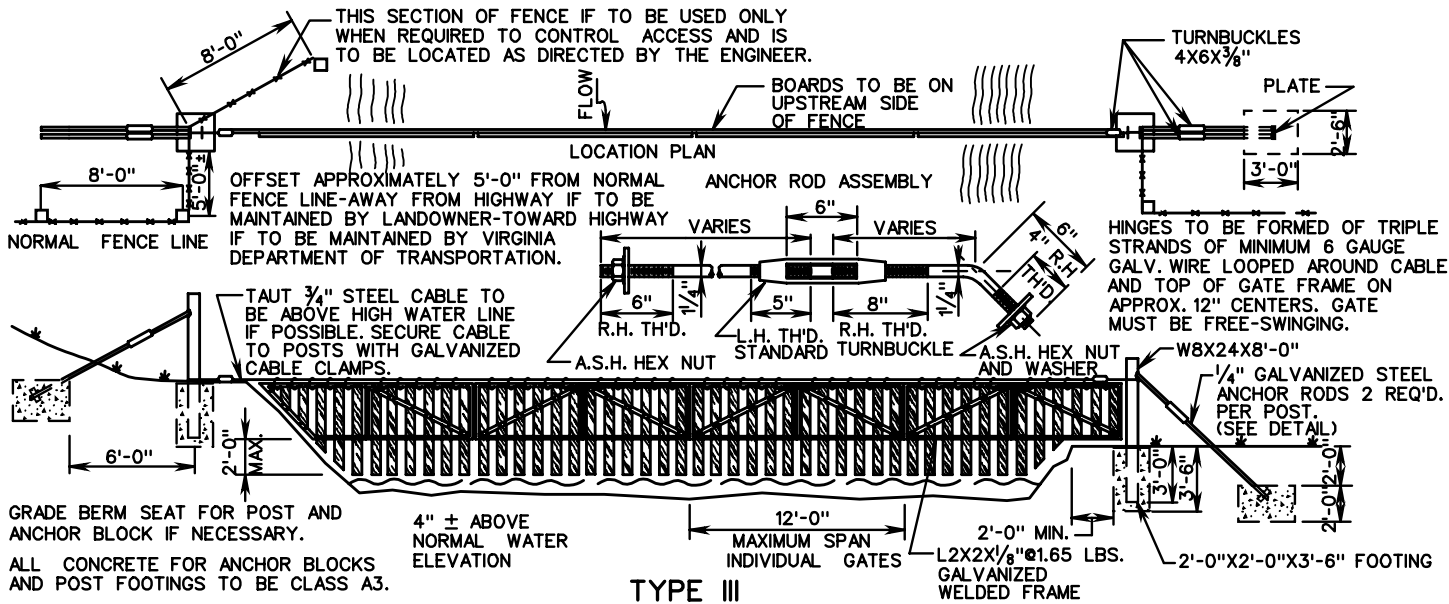
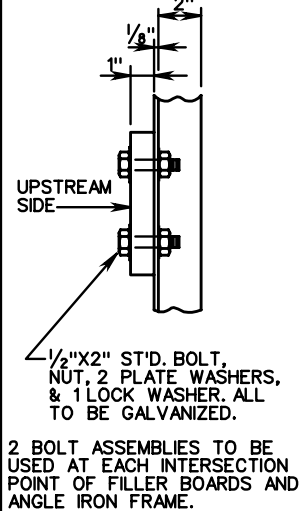

NOTES: WATER GATES MAY BE USED WITH STANDARD FE-W1, FE-W2 OR FE-B FENCE.  
 GATE IS TO BE FABRICATED TO CONFORM TO INDIVIDUAL CHANNEL REQUIREMENTS.  
 WOOD FILLER BOARDS TO BE 1" TREATED PINE BOLTED TO FRAME. SMOOTH WOOD SIDE IS TO FACE UPSTREAM.  
 TYPE I GATE IS TO HAVE TWO 8" END POSTS AS SPECIFIED FOR THE TYPE OF FENCE USED. THE ADJACENT TO END POST AND BRACING MAY BE ELIMINATED.  
 TYPE II GATE IS TO HAVE TWO 8" END POSTS, ADJACENT TO END POSTS, BRACING, ETC. AS SPECIFIED FOR THE TYPE OF FENCE USED.



ROAD AND BRIDGE STANDARDS

SHEET 1 OF 1

REVISION DATE

503.06

# WATER GATES IN FENCE LINES

VIRGINIA DEPARTMENT OF TRANSPORTATION

SPECIFICATION REFERENCE

242  
507  
236