

PLAN VIEW

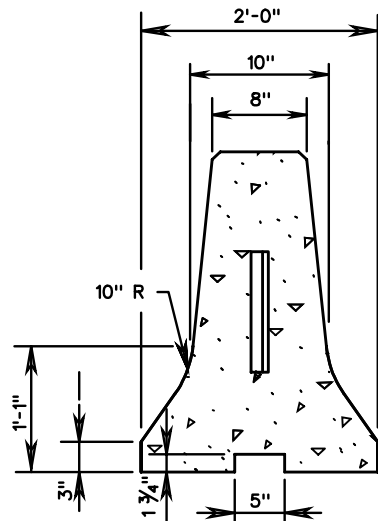

ELEVATION VIEW

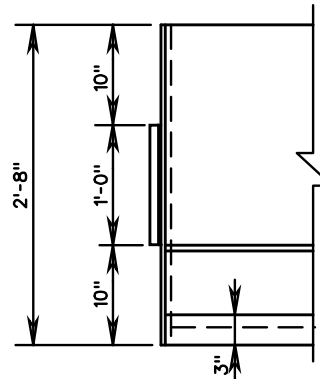

SIDE VIEW

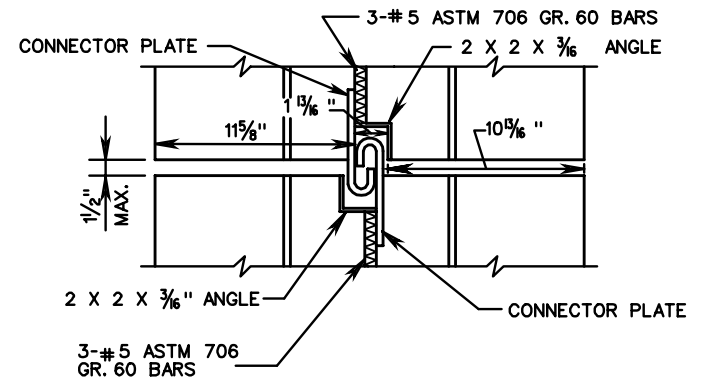

PLAN VIEW

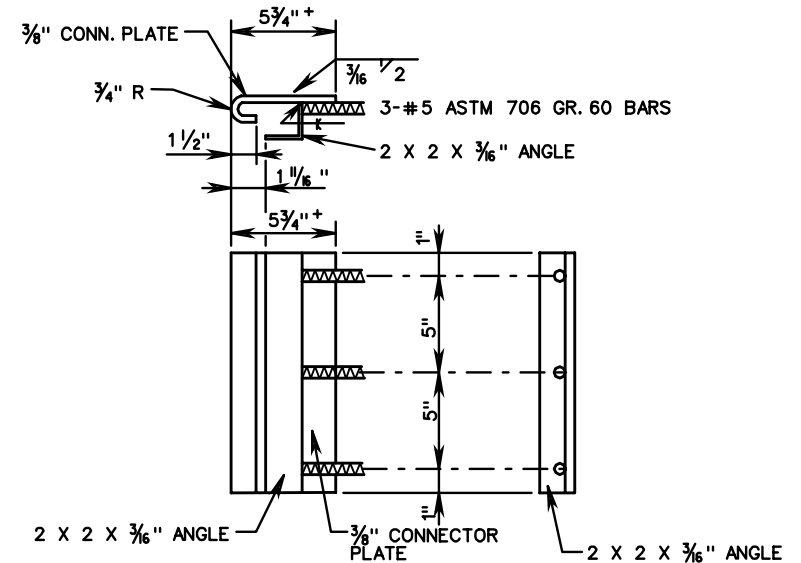

ELEVATION VIEW SIDE VIEW
CONNECTOR PLATE DETAIL

NOTES:

1. MINIMUM COMPRESSIVE STRENGTH OF CONCRETE AT THE AGE OF 28 DAYS SHALL BE 4000 PSI.
2. ALL REINFORCEMENT SHALL CONFORM TO ASTM A615, GRADE 60.
3. ALL EXPOSED METAL TO BE GALVANIZED FOR PERMANENT LOCATIONS.
4. ALL EXPOSED METAL SHALL BE GALVANIZED FOR TEMPORARY LOCATIONS.
5. J-J HOOK AS MANUFACTURED BY SMITH-MIDLAND.
6. BEGINNING WITH JANUARY 2000 ADVERTISEMENT ALL POSITIVE CONNECTIONS MUST BE APPROVED BY THE FHWA IN ACCORDANCE WITH NCHRP 350 TEST REQUIREMENTS.
7. REFER TO MANUFACTURER FOR TEMPORARY INSTALLATION DETAILS.

WHEN USING J-J HOOK BARRIER, ALLOW FOR A 4'-4" DYNAMIC DEFLECTION. PROVIDE A MIN. 69'-7" OF BARRIER UPSTREAM AND DOWNSTREAM OF WORK ZONE FOR ANCHORAGE.

J-J HOOK[®] DETAILS

PRECAST CONCRETE MEDIAN BARRIER
POSITIVE CONNECTION OPTIONS

VIRGINIA DEPARTMENT OF TRANSPORTATION



ROAD AND BRIDGE STANDARDS

REVISION DATE

SHEET 3 OF 5

502.22