

PLAN VIEW

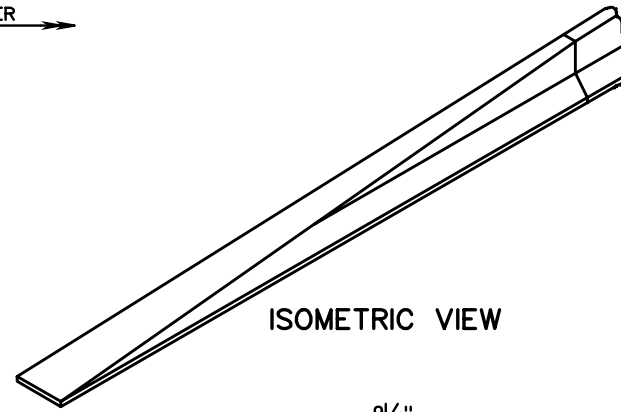

ISOMETRIC VIEW

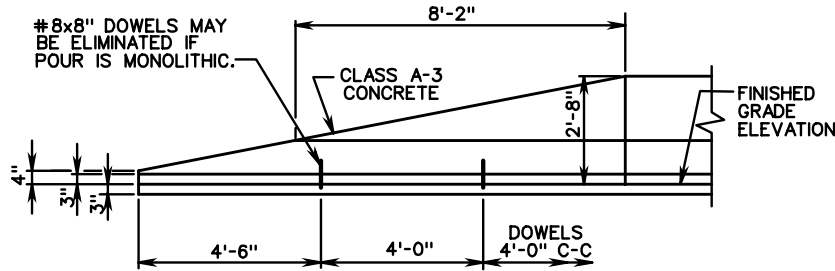

ELEVATION VIEW

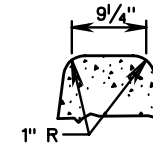

ALTERNATE TOP

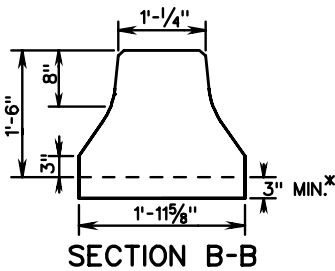

SECTION B-B

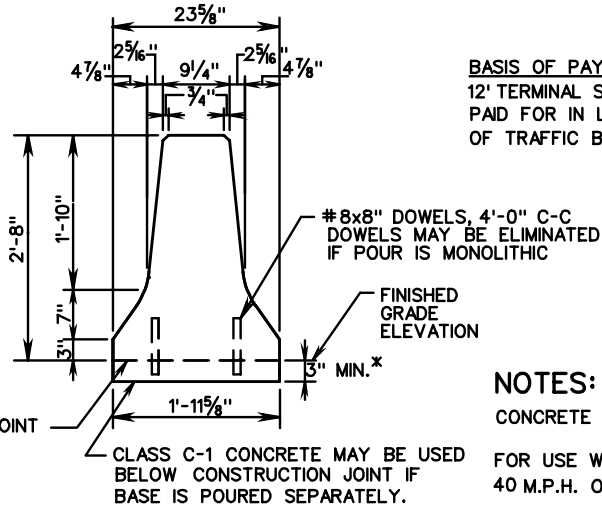

SECTION C-C

BASIS OF PAYMENT: CONCRETE MEDIAN BARRIER
12' TERMINAL SECTION IS TO BE MEASURED AND
PAID FOR IN LIN. FT. ST'D. MB-7D, OR LIN. FT.
OF TRAFFIC BARRIER SERVICE CONCRETE.

NOTES:

CONCRETE TO BE CLASS A3.

FOR USE WHERE THE OPERATING SPEED IS
40 M.P.H. OR LESS.

LOCATION OF THE BARRIER END SECTIONS TO
BE AS NOTED ON PLANS OR AS APPROVED
BY THE ENGINEER.

FOR POSITIVE CONNECTION DETAILS AND
DIMENSIONS SEE STANDARD MB-INS.

ONLY FOR USE OUTSIDE OF CLEAR ZONE.

* DEPTH OF CONCRETE BASE MAY BE EXTENDED
AT THE CONTRACTOR'S OPTION TO COINCIDE WITH
BOTTOM OF PAVEMENT COURSE IN WHICH BASE
TERMINATES; HOWEVER, THE COST OF ADDITIONAL
CONCRETE SHALL BE INCLUDED IN UNIT PRICE
BID PER LIN. FT. OF BARRIER.

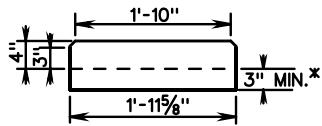

SECTION A-A



ROAD AND BRIDGE STANDARDS

SHEET 1 OF 1

REVISION DATE

502.09

CAST IN PLACE CONCRETE MEDIAN BARRIER
12 FT. TERMINAL SECTION

VIRGINIA DEPARTMENT OF TRANSPORTATION

SPECIFICATION
REFERENCE