

**NOTES:**

1. HIGH STRENGTH GROUT OR MORTAR SHALL BE IN ACCORDANCE WITH SECTION 218 OF THE SPECIFICATIONS.
2. 4" MIN. OR VARIABLE TO COINCIDE WITH SUBGRADE COURSE.
3. WHEN USED AS MEDIAN BARRIER IN A PERMANENT LOCATION, DRAINAGE SLOTS WILL BE COMPLETELY FILLED AND SEALED WITH MORTAR OR GROUT UNLESS UNIT WILL BE LOCATED OVER MEDIAN DRAINAGE STRUCTURE.
4. BARRIER DELINEATOR SIZE, COLOR, AND SPACING SHALL BE IN ACCORDANCE WITH THE SPECIFICATIONS.
5. COST OF DELINEATOR TO BE INCLUDED IN THE PRICE BID FOR MEDIAN BARRIER.
6. REFLECTIVE SURFACE OF BARRIER DELINEATOR IN ALL INSTANCES SHALL BE FACING ONCOMING TRAFFIC.
7. PIN AND CONNECTORS SHALL BE ASTM-A36. REINFORCING STEEL BARS SHALL BE ASTM A 615 GRADE 60. ONE CONNECTOR PIN ASSEMBLY WITH EACH BARRIER SECTION.

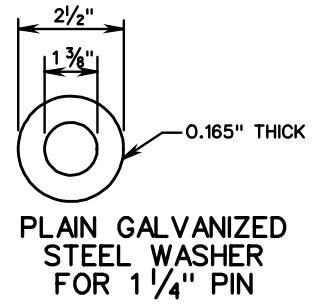
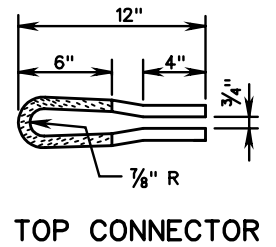
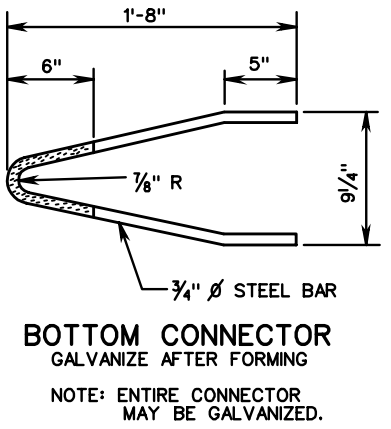
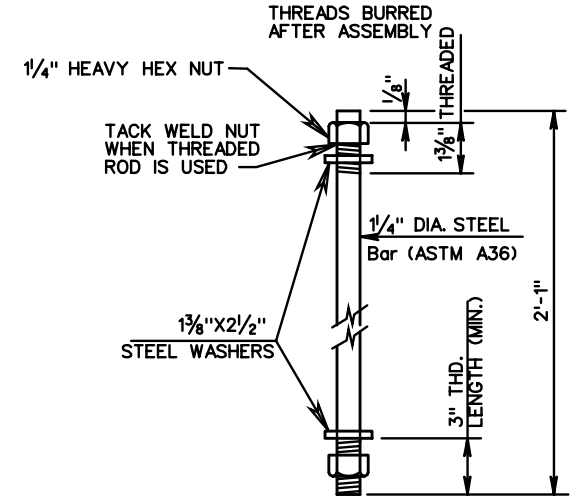
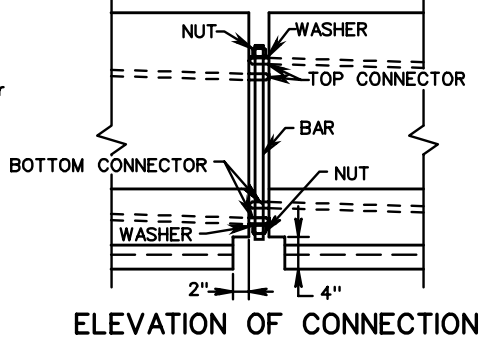
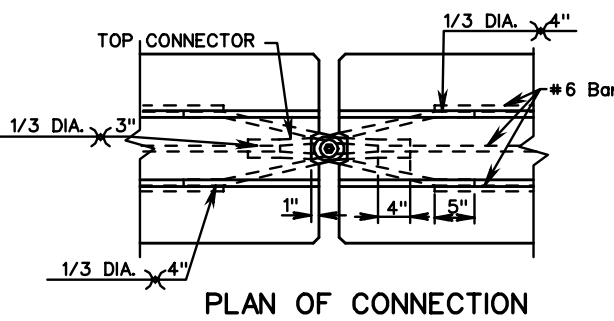

SPECIFICATION REFERENCE
105 512

**PRECAST TRAFFIC BARRIER SERVICE CONCRETE**

VIRGINIA DEPARTMENT OF TRANSPORTATION

<b>VDOT</b>	
ROAD AND BRIDGE STANDARDS	
REVISION DATE	SHEET 2 OF 2
502.06	