

GR-INS

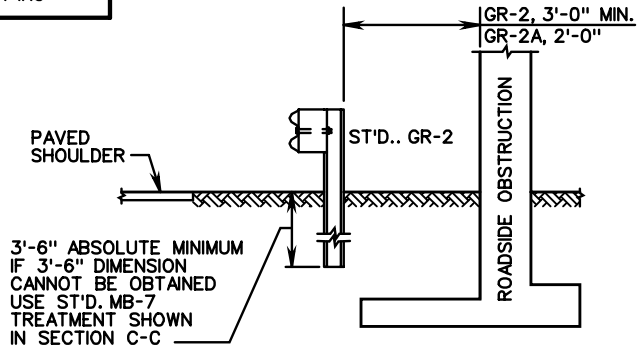

SECTION A-A

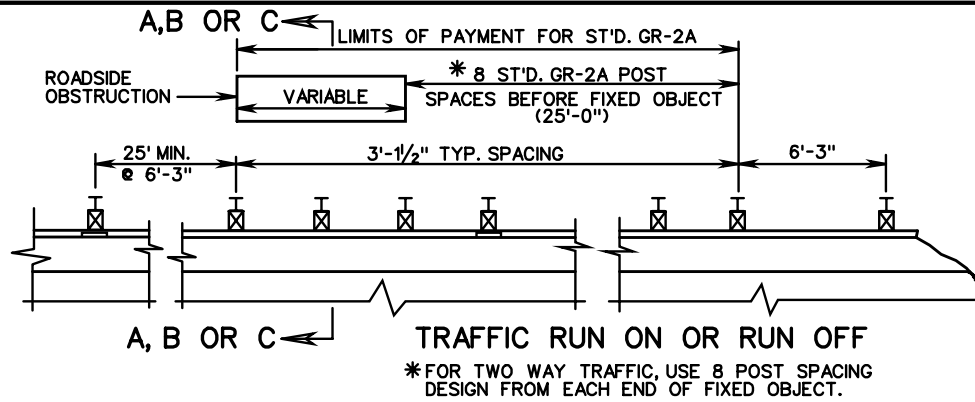

FOR USE WHERE DISTANCE FROM BACK OF GR-2A POST TO FIXED OBJECT IS LESS THAN 2'-0".

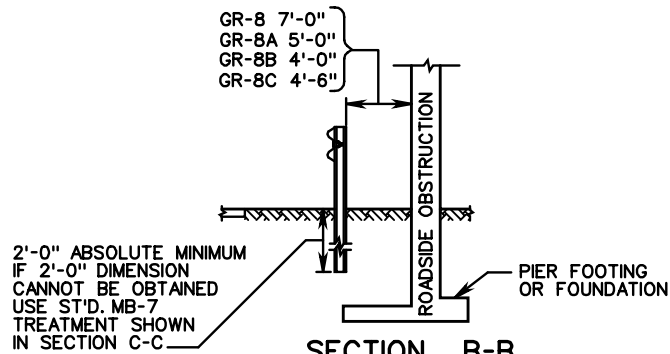

SECTION B-B

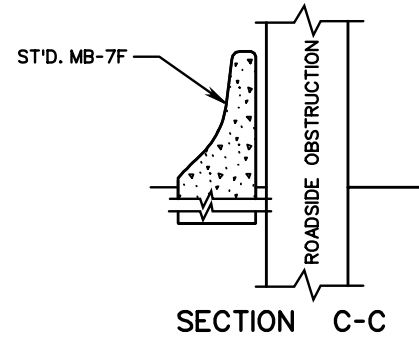

SECTION C-C

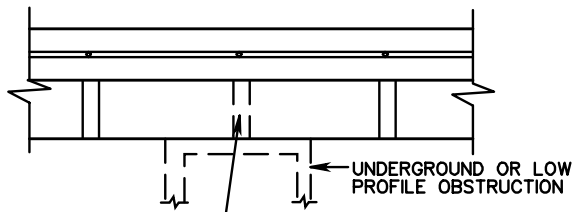

DETAIL OF SPECIAL DESIGN SITUATION

NOTE:
IF GROUND LEVEL OR UNDERGROUND FIXED OBJECT NECESSITATES THE ELIMINATION OF ONE OR MORE POSTS, A GR-10 OR A SPECIAL DESIGN WILL BE REQUIRED

ONE OR MORE POSTS AS REQUIRED TO AVOID OBJECT

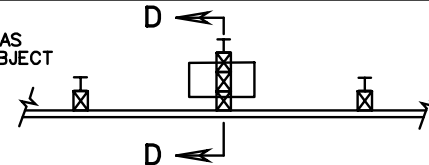

COST OF ADDITIONAL BLOCKOUT BRACKETS TO BE INCLUDED IN PRICE BID PER LINEAR FOOT OF GUARDRAIL.

3 BLOCKOUTS (MAX.) FOR ONE POST ONLY. TWO BLOCKOUTS MAY BE USED FOR A SERIES OF POSTS.

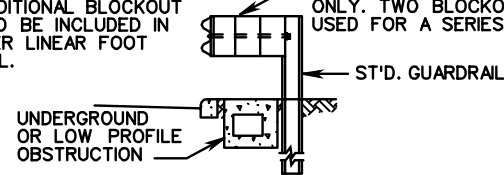

SECTION D-D
DETAIL OF MULTIPLE BLOCK-OUT TO AVOID UNDERGROUND OR LOW PROFILE OBSTRUCTION



ROAD AND BRIDGE STANDARDS

W BEAM GUARDRAIL INSTALLATION CRITERIA

SPECIFICATION REFERENCE

SHEET 3 OF 8

REVISION DATE

VIRGINIA DEPARTMENT OF TRANSPORTATION

501.36

221
505