

PLAN OF DOWEL UNIT FOR CONTRACTION JOINT

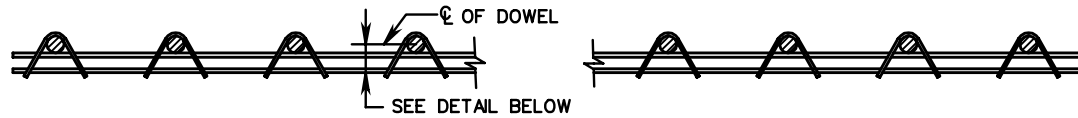

SIDE ELEVATION A - A CONTRACTION JOINT

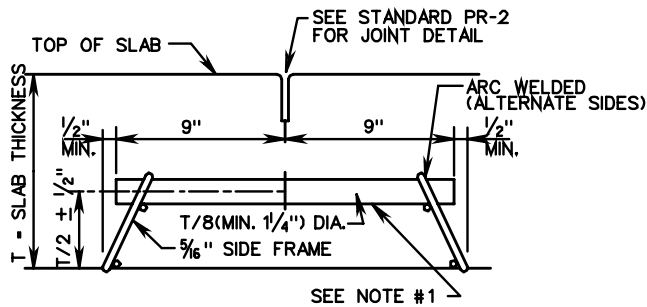

SECTION B - B
THRU CONTRACTION JOINT

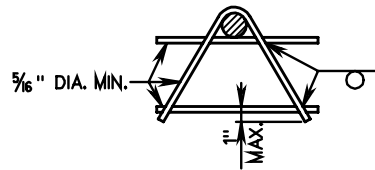

SIDE FRAME DETAIL

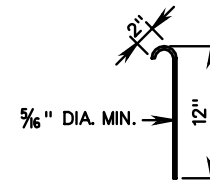

STAKING PIN

NOTES:

1. ENTIRE BAR TO BE LUBRICATED.
2. STAKING PINS, A MINIMUM SIX PER ASSEMBLY, THREE TO EACH SIDE.
3. EXPANSION AND CONTRACTION JOINTS: THE DEVICE FOR SUPPORTING DOWELS AT EXPANSION AND CONTRACTION JOINTS SHALL BE SO CONSTRUCTED THAT IT WILL HOLD THE DOWELS FIRMLY IN POSITION, PARALLEL TO THE SURFACE AND CENTERLINE OF THE SLAB.
4. NO MEMBERS SHALL BE PLACED SO THAT THEY WILL INTERFERE WITH THE FREE FLOW OF CONCRETE BETWEEN THE DOWELS.
5. ASSEMBLY AND WELDING OF ALL MEMBERS SHALL BE SUCH AS TO INSURE A GOOD WORKMANLIKE JOB, WITH ALL JOINTS TRUE AND SQUARE.
6. ASSEMBLIES WHICH HAVE BECOME WARPED OR DAMAGED IN TRANSIT OR STORAGE SO THEY WILL NOT CONFORM TO THE SUBGRADE SHALL NOT BE USED.
7. A SAMPLE OF THE SUPPORTING DEVICE SHALL BE SUBMITTED FOR APPROVAL PRIOR TO THE FILLING OF JOB ORDERS.

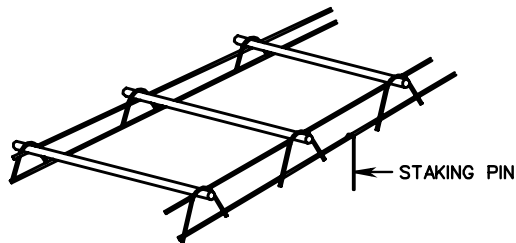

PERSPECTIVE VIEW



ROAD AND BRIDGE STANDARDS

SHEET 4 OF 5

REVISION DATE

301.04

STANDARD LOAD TRANSFER ASSEMBLY
CONTRACTION JOINT

VIRGINIA DEPARTMENT OF TRANSPORTATION

SPECIFICATION
REFERENCE