

MC-3B

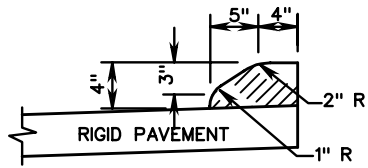

ASPHALT CURB

MC-3B

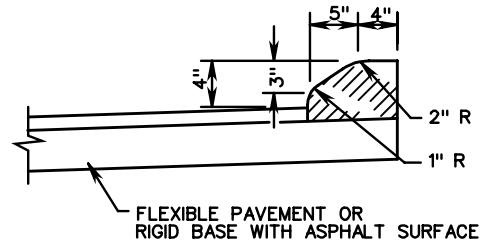

ASPHALT CURB

MC-3C

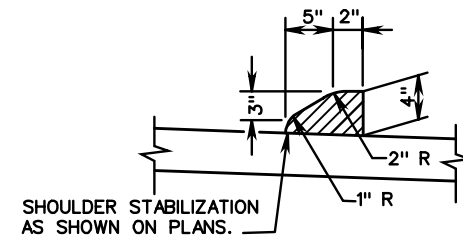

ASPHALT CURB  
FOR SLOPE EROSION CONTROL ONLY

MC-3B

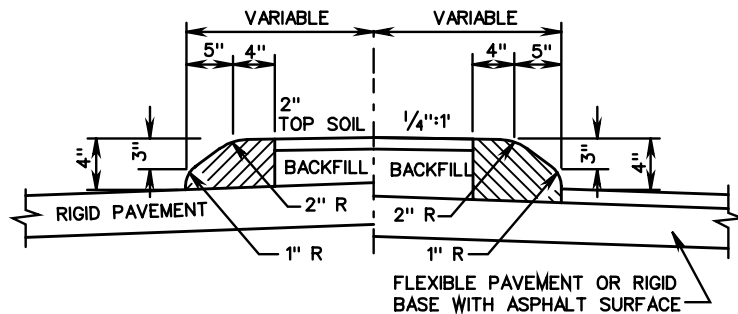

ASPHALT MEDIAN

MC-3B AND MC-3C ARE TO BE USED ON ROADWAYS MEETING THE REQUIREMENTS FOR CG-7 AS SHOWN IN APPENDIX A OF THE VDOT ROAD DESIGN MANUAL IN THE SECTION ON GS STANDARDS.

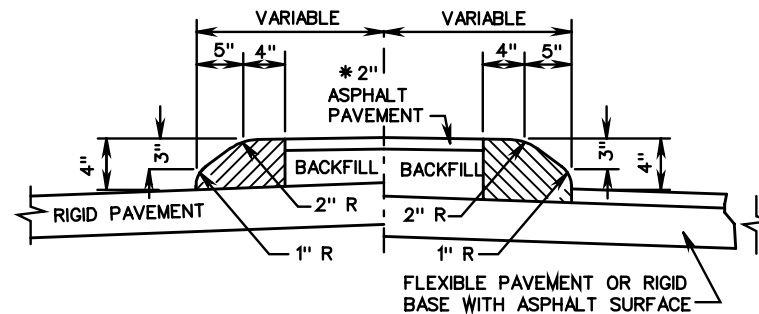

ASPHALT MEDIAN

\* ASPHALT TOP FOR MEDIAN TO BE SAME MIX AS CURB.



ROAD AND BRIDGE STANDARDS

SHEET 1 OF 1

REVISION DATE

201.06

# ASPHALT CONCRETE CURB AND MEDIAN

(FOR TEMPORARY OR PERMANENT INSTALLATION)

VIRGINIA DEPARTMENT OF TRANSPORTATION

SPECIFICATION REFERENCE

502