

NOTES:

1. THIS ITEM MAY BE PRECAST OR CAST IN PLACE.
2. CONCRETE TO BE CLASS A3 IF CAST IN PLACE, 4000 PSI IF PRECAST.
3. COMBINATION CURB & GUTTER HAVING A RADIUS OF 300 FEET OR LESS (ALONG FACE OF CURB) SHALL BE PAID FOR AS RADIAL COMBINATION CURB & GUTTER.
4. FOR USE WITH STABILIZED OPEN-GRADED DRAINAGE LAYER, THE BOTTOM OF THE CURB AND GUTTER SHALL BE CONSTRUCTED PARALLEL TO THE SLOPE OF SUBBASE COURSES AND TO THE DEPTH OF THE PAVEMENT.
5. ALLOWABLE CRITERIA FOR THE USE OF CG-7 IS BASED ON ROADWAY CLASSIFICATION AND DESIGN SPEED AS SHOWN IN APPENDIX A OF THE VDOT ROAD DESIGN MANUAL IN THE SECTION ON URBAN GS STANDARDS.
6. WHEN THIS STANDARD IS TO BE TIED INTO EXISTING BARRIER CURB, THE TRANSITION IS TO BE MADE WITHIN 10' OR THE CHANGE IN STANDARDS CAN BE MADE AT REGULAR OPENINGS.
7. WHEN COMBINATION MOUNTABLE CURB AND GUTTER IS USED, THE STANDARD ENTRANCE GUTTERS OR STANDARD CONNECTION FOR STREET INTERSECTIONS ARE TO HAVE THE MOUNTABLE CURB CONFIGURATION INCORPORATED.

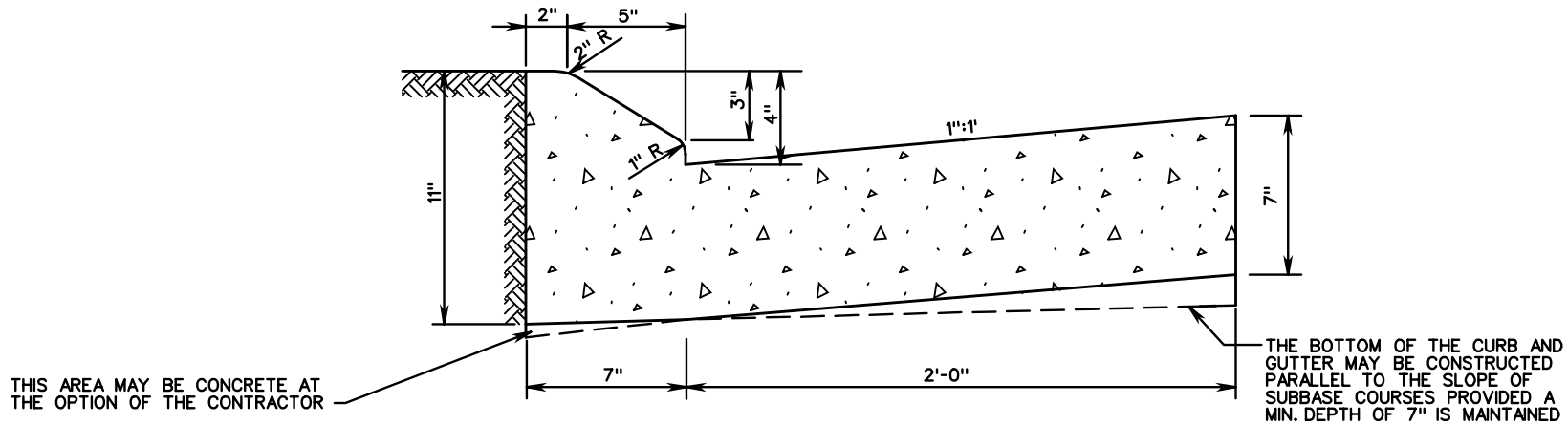

ROAD AND BRIDGE STANDARDS

SHEET 1 OF 1

REVISION DATE

201.04

COMBINATION 4" CURB AND GUTTER

VIRGINIA DEPARTMENT OF TRANSPORTATION

SPECIFICATION REFERENCE

105
502