

**FORCE MAIN DISCHARGE  
TYPE 1**

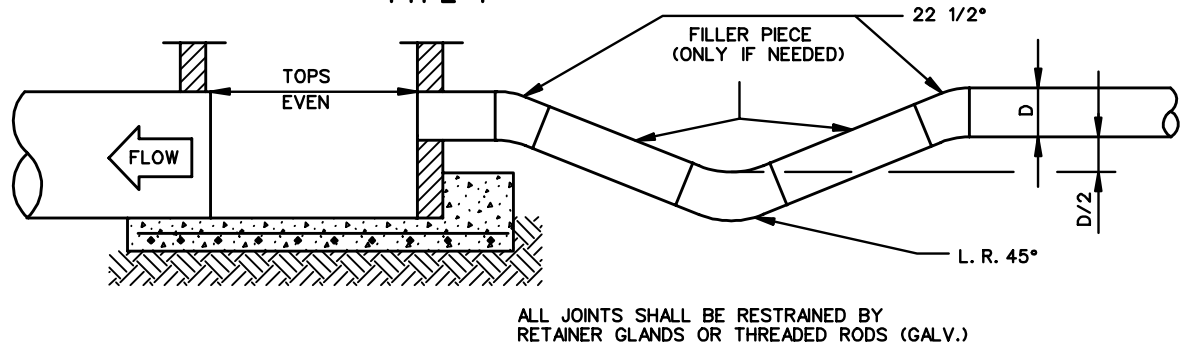

**FORCE MAIN DISCHARGE  
TYPE 2**

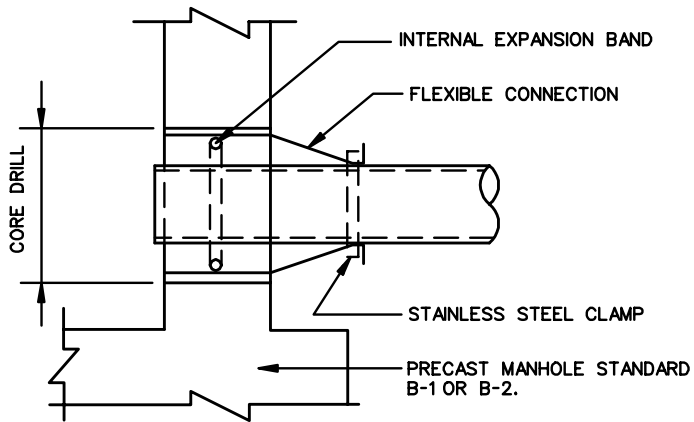

**FLEXIBLE CONNECTION**

PIPE TO PRECAST MANHOLE CONNECTIONS SHALL BE MADE WITH A FLEXIBLE BOOT. THE BOOT SHALL MEET ASTM SPECIFICATION C-923 AND CONSIST OF NEOPRENE RUBBER, EPDM RUBBER, OR POLYISOPRENE RUBBER, WHERE PREFERENCE MAY BE GIVEN TO A CERTAIN MATERIAL IN PROJECT SPECIFIC INSTANCES. THE INTERNAL EXPANSION BAND TO SECURE THE BOOT IN PLACE SHALL BE COMPOSED OF STAINLESS STEEL OR A NON-METALLIC MATERIAL. THE EXTERNAL BAND TO CLAMP AND SEAL THE BOOT TO THE PIPE SHALL BE CORROSION RESISTANT STAINLESS STEEL CONFORMING TO ASTM SPECIFICATION A-167. THE PORT TO RECEIVE THE BOOT SHALL BE CORE DRILLED AND SHOULD BE MANUFACTURED TO ALLOW FOR LATERAL AND VERTICAL MOVEMENT. ALL FIELD INSTALLATION OF PIPE THRU MANHOLE SEAL SHALL BE DONE IN ACCORDANCE WITH THE MANUFACTURER'S RECOMMENDATIONS AND SPECIFICATIONS.



ROAD AND BRIDGE STANDARDS

SHEET 2 OF 2

REVISION DATE

1411.02

**SANITARY SEWER MANHOLE  
WATER AND SANITARY SEWER FACILITIES**

VIRGINIA DEPARTMENT OF TRANSPORTATION

SPECIFICATION  
REFERENCE