

TYPICAL GUSSET PLATE CONNECTION

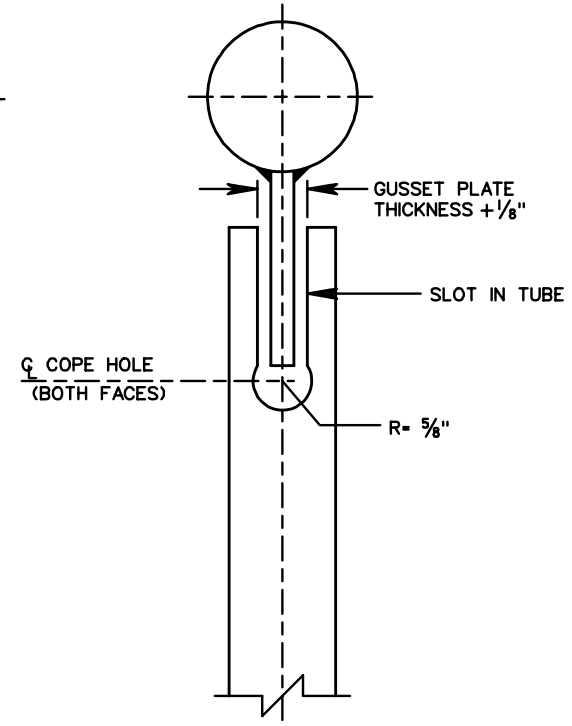

SECTION VIEW

**NOTES:**

1. ALL SECONDARY MEMBERS IN BOTH THE OVERHEAD TRUSS AND END POLE SUPPORTS SHALL BE JOINED TO PRIMARY MEMBERS USING A GUSSET CONNECTION PLATE.
2. CONTRACTOR SHALL SPECIFY THE WIDTH, LENGTH, AND THICKNESS OF GUSSET PLATE.
3. CONTRACTOR SHALL SPECIFY THE MINIMUM WELD SIZE AND LENGTH OF WELD.
4. COPE HOLES TO BE PROVIDED AT BOTH ENDS AND BOTH FACES OF ALL SECONDARY MEMBER CONNECTIONS.



ROAD AND BRIDGE STANDARDS

SHEET 3 OF 7

REVISION DATE

1324.12

**OVERHEAD SIGN STRUCTURE**

**GUSSET PLATE CONNECTION**

VIRGINIA DEPARTMENT OF TRANSPORTATION

SPECIFICATION REFERENCE

700