

SHIM DETAIL

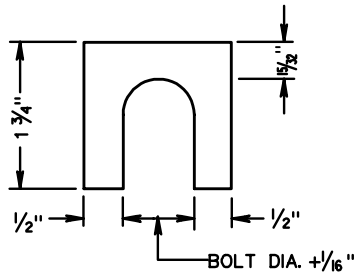

FURNISH 2 EACH .063"± AND 2 EACH .032"± THICK SHIMS PER POLE. SHIMS SHALL BE FABRICATED FROM BRASS CONFORMING TO ASTM B36 OR FROM STAINLESS STEEL WITH A MINIMUM CHROMIUM CONTENT OF 11.50%. NO MORE THAN 2 SHIMS SHALL BE USED PER BOLT WITH A MAXIMUM OF 4 SHIMS PER POST.

HINGE PLATE DETAIL

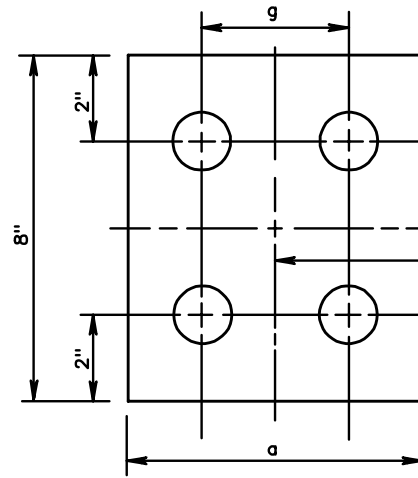

FUSE PLATE DETAIL

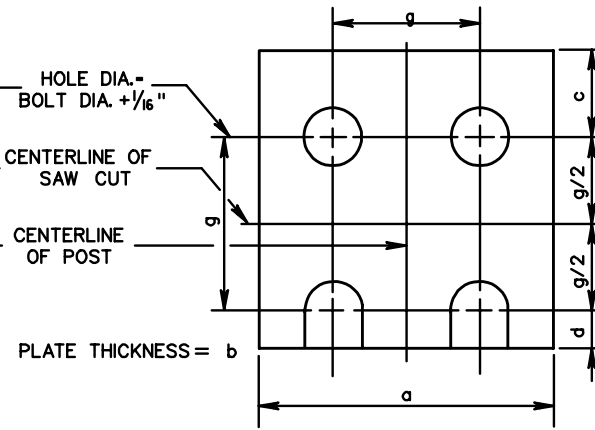

STIFFENER PLATE

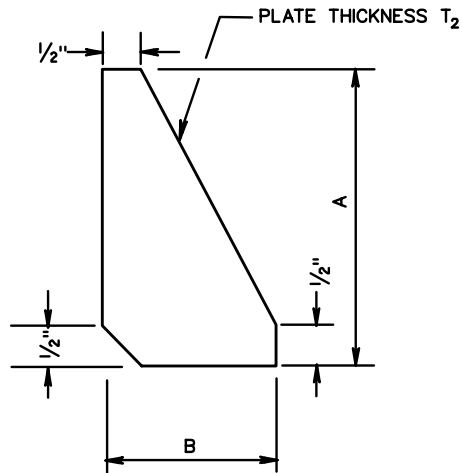

BOLT KEEPER PLATE

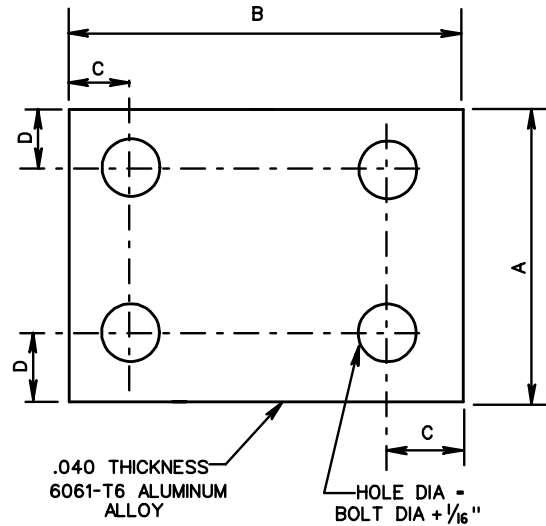

ALTERNATE BOLT KEEPER PLATE

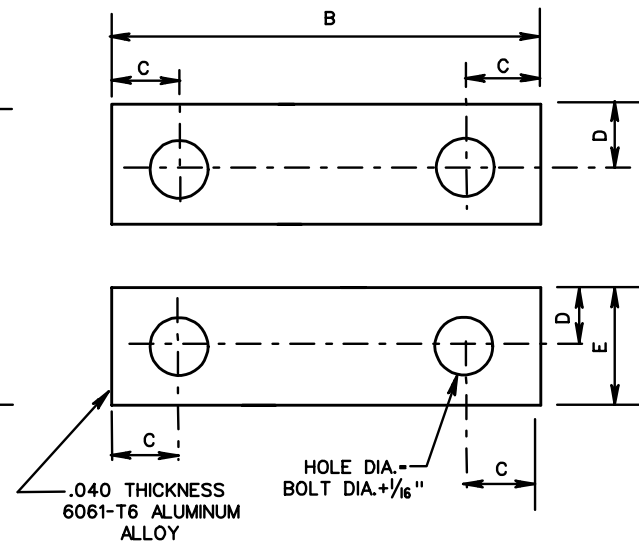

ROAD AND BRIDGE STANDARDS

SHEET 3 OF 10

REVISION DATE

1323.12

INTERSTATE SIGN STRUCTURE  
INSTALLATION DETAILS

VIRGINIA DEPARTMENT OF TRANSPORTATION

SPECIFICATION  
REFERENCE

700