

FOUNDATION DETAILS

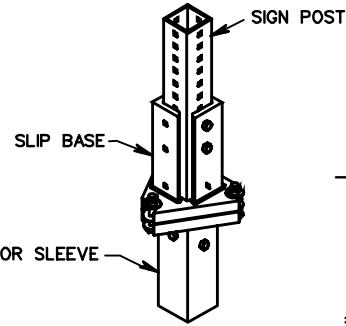

DETAIL B

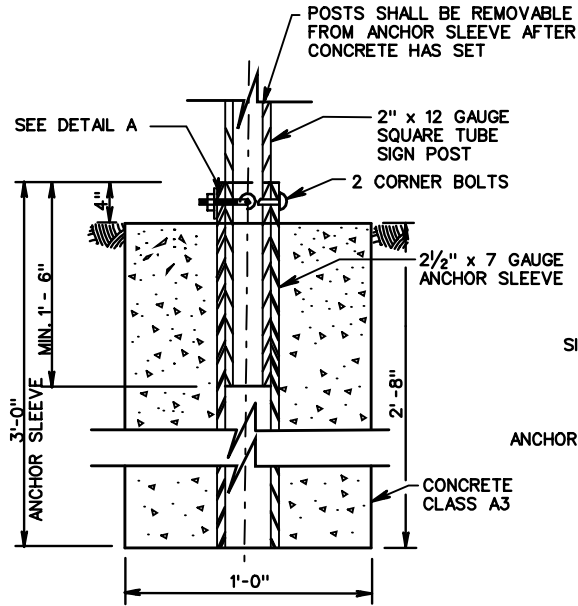
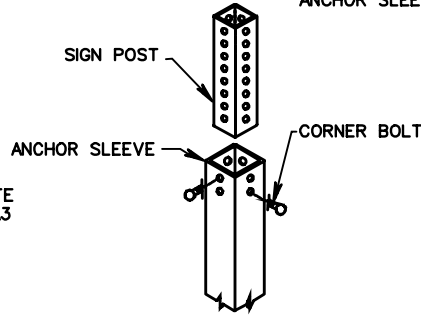

DETAIL A

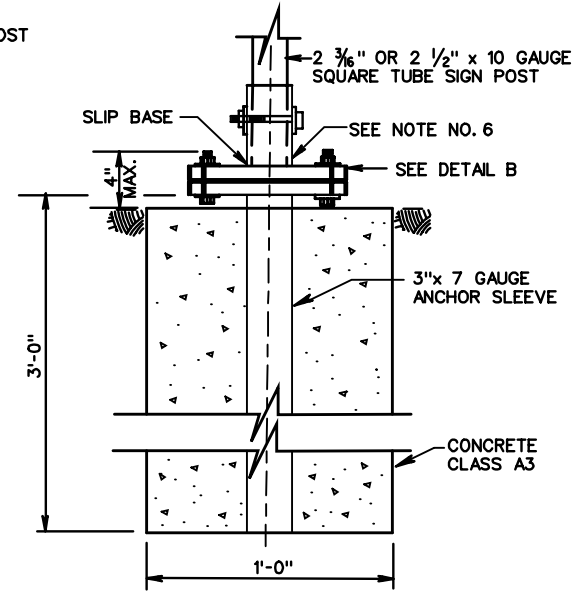

SIGN POST TO BE INSTALLED ON SLIP BASE IN ACCORDANCE WITH MANUFACTURERS RECOMMENDATIONS

SIGN PANEL ATTACHMENT DETAILS

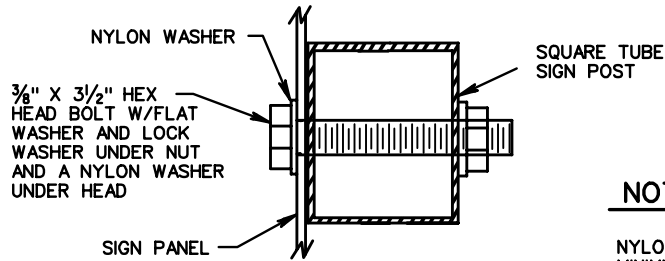

NOTES:

NYLON WASHER SHALL BE 1/16" THICK MINIMUM WITH AN OUTSIDE DIAMETER OF 1" AND AN INSIDE DIAMETER OF 7/16".

TOP OF SIGN PANEL SHALL BE FLUSH WITH THE TOP OF THE POST.

SIGN PANEL DESIGN SHALL BE IN ACCORDANCE WITH STANDARD SPD-5.

CORNER BOLT

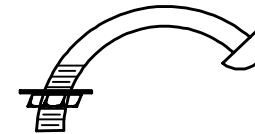

CORNER BOLTS SHALL BE 5/16" DIA. CARRIAGE HEAD BOLT WITH SERRATED FLANGE NUT.

CORNER BOLTS SHALL BE USED FOR ATTACHING THE SQUARE TUBE SIGN POST TO THE ANCHOR SLEEVE OR SLIP BASE.



ROAD AND BRIDGE STANDARDS

SHEET 2 OF 3

REVISION DATE

1321.11

SQUARE TUBE SIGN POST

VIRGINIA DEPARTMENT OF TRANSPORTATION

SPECIFICATION REFERENCE

700