

METHOD OF POST DRILLING

SIDE VIEW

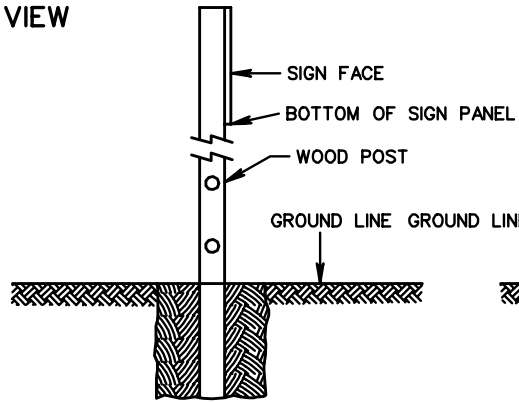

FRONT VIEW

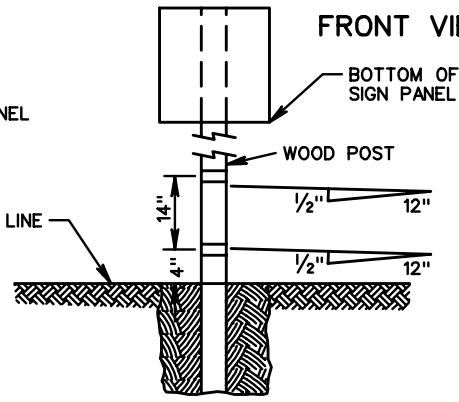

6" X 6" WOOD POST REQUIRES TWO 2" BORE HOLES.

6" X 8" WOOD POST REQUIRES TWO 3" BORE HOLES. POSTS LESS THAN 6" X 6" DO NOT REQUIRE BORE HOLES.

FLAT CUT



SHED CUT

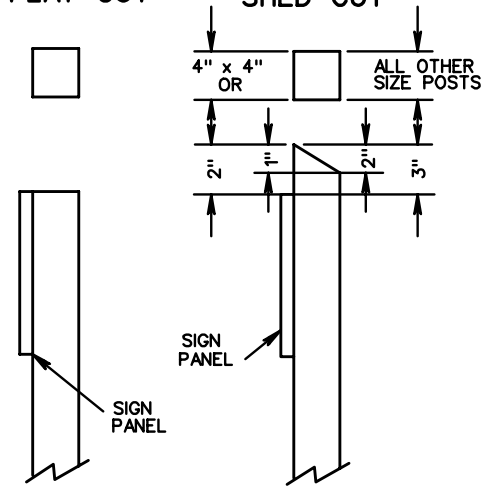

PYRAMIDAL CUT

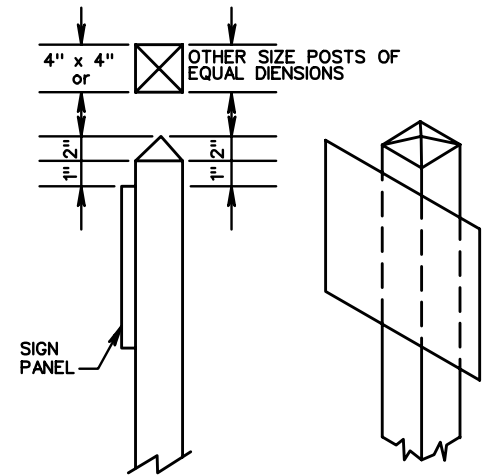

SIGN PANEL ATTACHMENT DETAILS

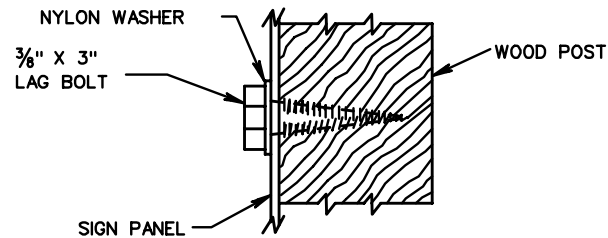

NOTES:

NYLON WASHER SHALL BE 1/8" THICK MINIMUM WITH AN OUTSIDE DIAMETER OF 1" AND AN INSIDE DIAMETER OF 7/16".

SIGN PANEL DESIGN SHALL BE IN ACCORDANCE WITH ST'D. SPD-5.

SPECIFICATION REFERENCE

700

WOOD POST SIGN STRUCTURES
FOR CONSTRUCTION ZONES
VIRGINIA DEPARTMENT OF TRANSPORTATION

VDOT

ROAD AND BRIDGE STANDARDS

REVISION DATE

SHEET 2 OF 3

1320.11