

SECTION A-A

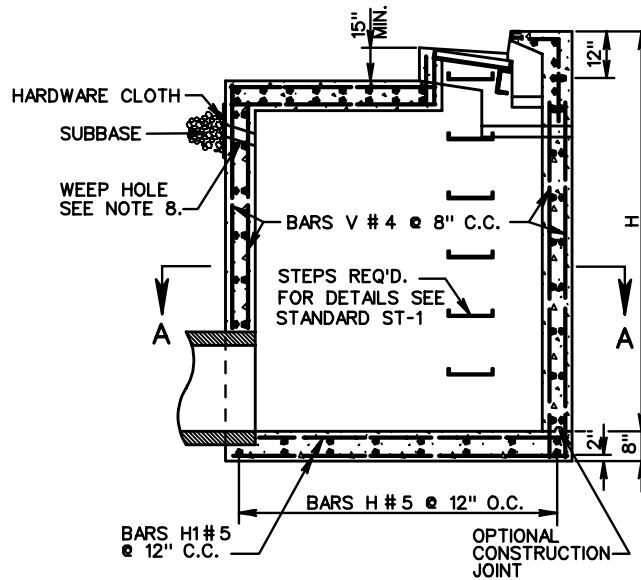

SECTION THROUGH ELEVATION

SCHEDULE OF REINFORCING STEEL		
BARS MARK	NO. REQUIRED	LENGTH
H	4(1.5H+1)+16	5'-8"
H1	4(1.5H+1)+12	7'-8"
V	76	H-1'-2"

- NOTES**
- DEPTH OF INLET (H) TO BE SHOWN ON PLANS.
  - THE "H" DIMENSION SHOWN ON THE STANDARDS AND SPECIFIED ON THE PLANS WILL BE MEASURED FROM THE INVERT OF THE OUTFALL PIPE TO THE TOP OF THE STRUCTURE. PLAN "H" DIMENSIONS ARE APPROXIMATE ONLY FOR ESTIMATING PURPOSES AND THE ACTUAL DIMENSIONS SHALL BE DETERMINED BY THE CONTRACTOR FROM FIELD CONDITIONS.
  - WHEN SPECIFIED ON THE PLANS THE INVERT IS TO BE SHAPED IN ACCORDANCE WITH STANDARD IS-1. THE COST OF FURNISHING AND PLACING ALL MATERIALS INCIDENTAL TO THE SHAPING IS TO BE INCLUDED IN THE BID PRICE FOR THE STRUCTURE.
  - IN THE EVENT THE INVERT OF THE OUTFALL PIPE IS HIGHER THAN THE BOTTOM OF THE STRUCTURE, THE INVERT OF THE STRUCTURE SHALL BE SHAPED WITH CEMENT MORTAR TO PREVENT STANDING OR PONDING OF WATER IN THE STRUCTURE. THE COST OF FURNISHING AND PLACING ALL MATERIALS INCIDENTAL TO THE SHAPING IS TO BE INCLUDED IN THE BID PRICE FOR THE STRUCTURE.
  - STEPS ARE TO BE PROVIDED WHEN H IS 4'-0" OR GREATER. FOR DETAILS SEE STANDARD ST-1.
  - THIS ITEM MAY BE PRECAST OR CAST-IN-PLACE.
  - # 4 X 8" SMOOTH DOWELS AT APPROXIMATELY 12" C-C TO BE PLACED IN ALL AREAS ADJACENT TO ABUTTING CONCRETE TO PREVENT SETTLEMENT. IN LIEU OF DOWELS A 2" X 4" NOTCH MAY BE PROVIDED. SEE STANDARD T-DI-3, 4 FOR ALTERNATE DESIGN.
  - 3" DIAMETER WEEP HOLE TO BE LOCATED TO DRAIN SUBBASE MATERIAL. WEEP HOLE WITH 12"X12" PLASTIC HARDWARE CLOTH 1/4" MESH OR GALVANIZED STEEL WIRE, MINIMUM WIRE DIAMETER 0.03", NUMBER 4 MESH HARDWARE CLOTH ANCHORED FIRMLY TO THE OUTSIDE OF THE STRUCTURE.
  - ALL REINFORCING STEEL SHALL HAVE A MIN. COVER OF 2".
  - ALL REINFORCING STEEL TO BE CUT CLEAR OF ALL OPENINGS BY 2".
  - CAST-IN PLACE CONCRETE IS TO BE CLASS A3 (3000 PSI). PRECAST CONCRETE IS TO BE 4000 PSI.
  - LENGTH OF SLOT (L) WILL, IN EVERY CASE, BE SHOWN ON PLANS.
  - THIS STANDARD IS INTENDED FOR USE IN CURB AND GUTTER SITUATIONS ONLY.
  - IF OPTIONAL CONSTRUCTION JOINT IS USED IT IS TO BE KEYS. ALL SPLICES IN BARS V TO BE A MINIMUM OF 40D (20").
  - FOR PLAN VIEW OF INLET SEE STANDARD DI-2D, 2E, 2F.
  - PROVIDE SAFETY SLABS WHEN SPECIFIED ON THE PLANS.
  - FOR DESCRIPTION AND LOCATION OF DIMENSION L SEE SHEET 104.06.
  - FOR NUMBER OF BARS A-M REQUIRED AND LENGTHS SEE SHEET 104.07.
  - QUANTITIES SHOWN ARE FOR MIN. INLETS OF EACH TYPE. FOR INLETS OF GREATER DEPTH (H) OR LARGER SLOTS (L), INCREMENTS SHOWN PER FOOT MUST BE ADDED. THE AMOUNT OF CONCRETE AND STEEL DISPLACED MUST BE DEDUCTED TO OBTAIN TRUE QUANTITIES.
  - FOR DETAILS AND DIMENSIONS OF CURB, SLOT, BEAM, COLLAR AND GRATE, DROPPED GUTTER LINE, AND REINFORCING AND STRUCTURAL STEEL NOT DETAILED SEE STANDARD DI-2D.
  - INLET MAY BE USED WITH LARGER LONGITUDINAL PIPE (72" MAXIMUM) PROVIDED HORIZONTAL CLEARANCE BETWEEN ADJACENT PIPES IS ADEQUATE.

APPROXIMATE QUANTITIES FOR MINIMUM 9' DEPTH INLET			
DI-TYPE	DIMENSION L SEE NOTE 17 Lin. Ft.	REINFORCING STEEL Lbs.	CONCRETE Cu. Yds.
2DD	4'-8"	1,683	6.93
2EE	6'-0"	1,714	7.20
2FF	6'-0"	1,733	7.25

INCREMENTS TO BE ADDED FOR EACH ADDITIONAL FOOT OF DEPTH (H) AND OR SLOT LENGTH (L)				
DI-TYPE	H		L	
	CONCRETE	STEEL	CONCRETE	STEEL
	Cu. Yds.	Lbs.	Cu. Yds.	Lbs.
2DD	0.63	191	—	—
2EE	0.63	191	0.16	17
2FF	0.63	191	0.16	17

SPECIFICATION REFERENCE
233
302

**STANDARD CURB DROP INLET**  
 30" - 48" PIPE: DEPTH (H) = 9' TO 20'  
 VIRGINIA DEPARTMENT OF TRANSPORTATION

VDOT ROAD AND BRIDGE STANDARDS	
REVISION DATE	SHEET 1 OF 1
	104.08