

STANDARD	TITLE	PAGE
BDP-3	BRIDGE CONSTRUCTION AND WIDENING DATE PLATES	1101.01
	BRIDGE CONSTRUCTION AND WIDENING DATE PLATES	1101.02

INDEX OF SHEETS
SECTION 1100-MISC. STRUCTURE & BRIDGE
 VIRGINIA DEPARTMENT OF TRANSPORTATION



ROAD AND BRIDGE STANDARDS

REVISION DATE

SHEET 1 OF 1

1100.01

THIS PAGE INTENTIONALLY LEFT BLANK



ROAD AND BRIDGE STANDARDS

SHEET 1 OF 1

REVISION DATE

1100.02

VIRGINIA DEPARTMENT OF TRANSPORTATION

SPECIFICATION
REFERENCE

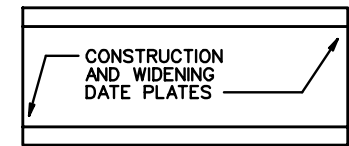
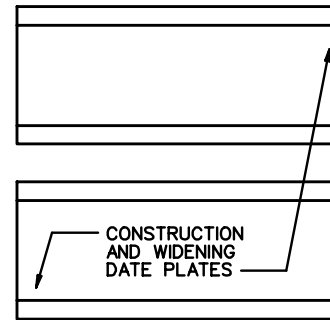
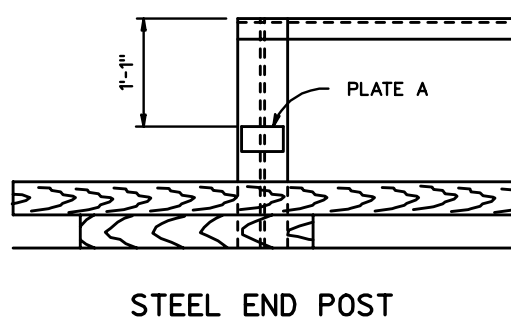
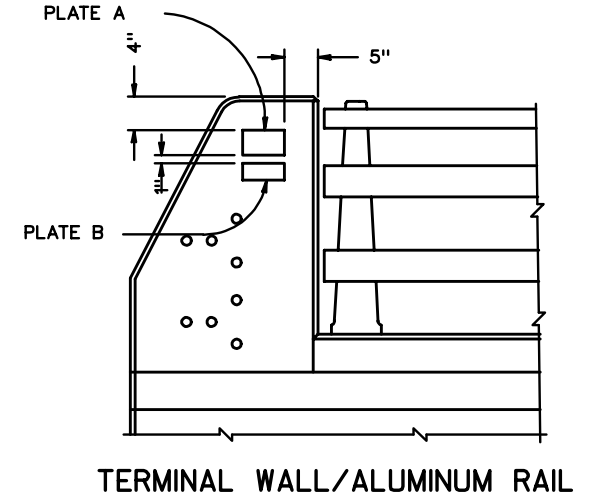
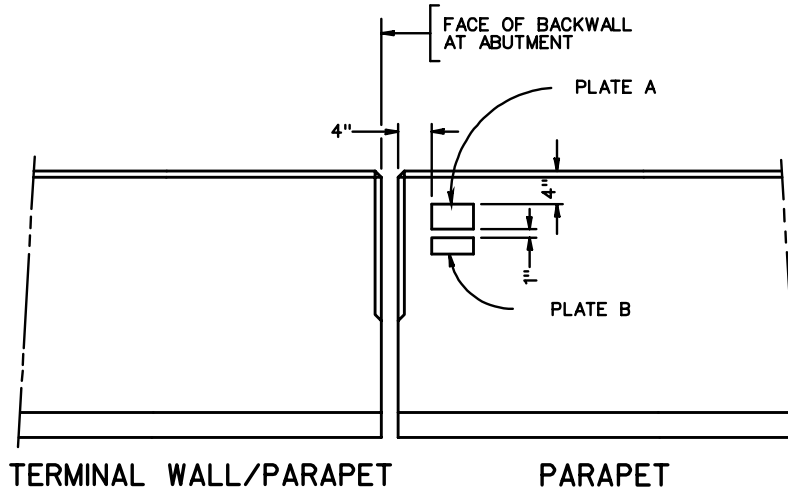

BRIDGE CONSTRUCTION AND WIDENING DATE PLATES
(PLACEMENT DETAILS)

VIRGINIA DEPARTMENT OF TRANSPORTATION



ROAD AND BRIDGE STANDARDS

REVISION DATE

SHEET 1 OF 2

1101.01

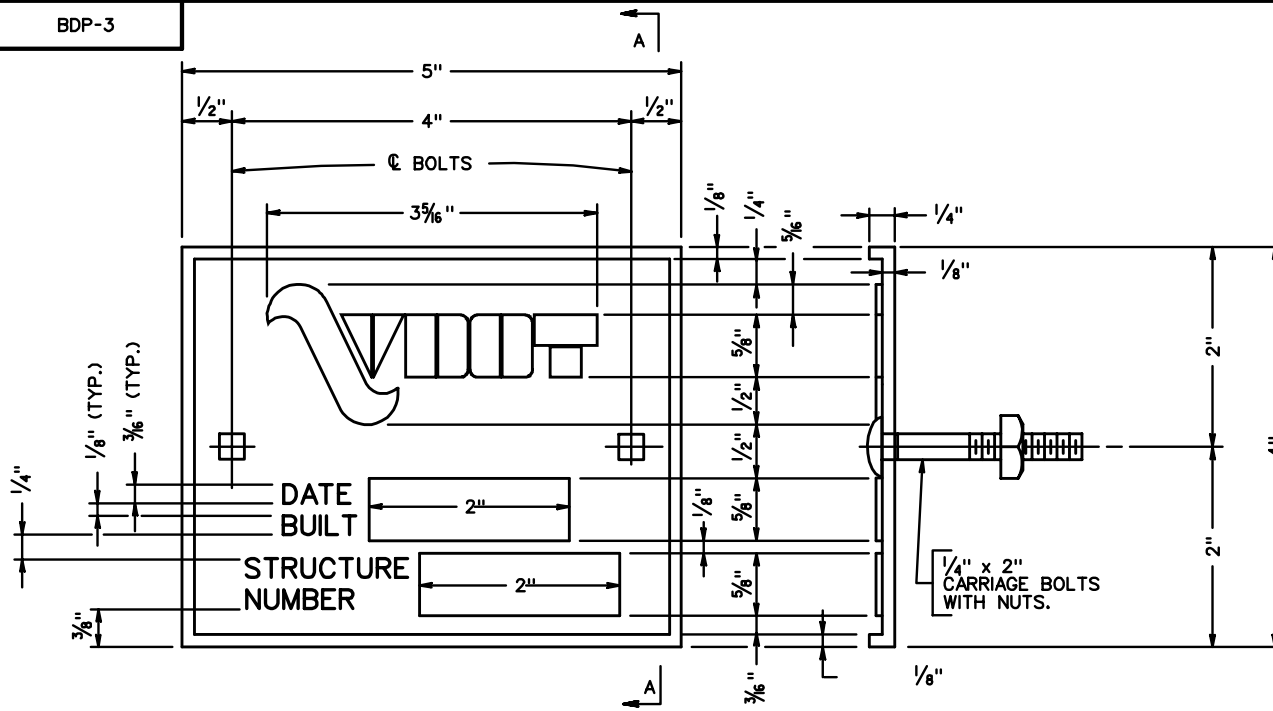

ELEVATION

SECTION A-A

PLATE A
SCALE: 1/2" = 1'-0"

NOTES

- DATE PLATE A & B SHALL BE BRONZE.
- ALL RAISED SURFACES SHALL HAVE A BRIGHT FINISH.
- DATE BUILT AND STRUCTURE NUMBER TO BE STAMPED ON PLATED WITH A 1/2" STEEL NUMBERING STAMP BY STATE PERSONNEL.
- CARRIAGE BOLTS AND NUTS MAY BE BRONZE OR STAINLESS STEEL.

* NUTS REQUIRED ONLY FOR STEEL END POST.

1/4" x 2" CARRIAGE BOLTS WITH NUTS.*

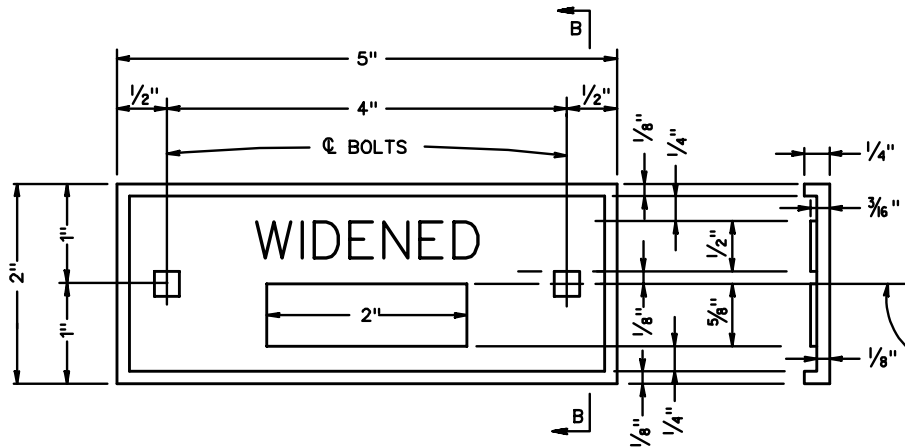

ELEVATION

SECTION B-B

PLATE B
SCALE: 1/2" = 1'-0"

