

SECTION 100

DRAINAGE ITEMS

STANDARD	TITLE	PAGE
EW-1, 1A	STANDARD ENDWALL FOR PIPE CULVERTS 12" - 36" CIRCULAR AND 23" X 14" - 53" X 34" ELLIPTICAL PIPES	101.01
EW-1PC, 1APC	PRECAST ENDWALL FOR PIPE CULVERTS 12" - 36" CIRCULAR AND 23" X 14" - 53" X 34" ELLIPTICAL PIPES	101.02
EW-2, 2A	STANDARD ENDWALL FOR PIPE CULVERTS 42" - 96" CIRCULAR AND 60" X 38" - 106" X 68" ELLIPTICAL PIPES	101.03
	STANDARD ENDWALL FOR PIPE CULVERTS 42" - 96" CIRCULAR	101.04
	STANDARD ENDWALL FOR PIPE CULVERTS 60" X 38" - 106" X 68" ELLIPTICAL PIPES	101.05
EW-2PC	PRECAST ENDWALL FOR 42" - 96" CIRCULAR PIPE CULVERTS	101.06
EW-2APC	PRECAST ENDWALL FOR 60" X 38" - 106" X 68" ELLIPTICAL PIPE CULVERTS	101.07
EW-2S	STANDARD ENDWALLS FOR 42" - 96" PIPE CULVERTS 30 AND 45 DEGREE SKEWS	101.08
	STANDARD ENDWALLS FOR 42" - 96" PIPE CULVERTS 30 AND 45 DEGREE SKEWS	101.09
EW-2SPC	PRECAST ENDWALLS FOR PIPE CULVERTS 42" - 96" PIPE 30 AND 45 DEGREE SKEW	101.10
EW-6	ENDWALL FOR MULTIPLE PIPE CULVERTS 12" - 36" PIPES	101.11
EW-6PC	PRECAST ENDWALLS FOR MULTIPLE PIPE CULVERTS 12" - 36" PIPE	101.12
EW-6S	ENDWALLS FOR MULTIPLE PIPE CULVERTS 12" - 36" PIPE 30 DEGREE SKEW	101.13
	ENDWALLS FOR MULTIPLE PIPE CULVERTS 12" - 36" PIPE 45 DEGREE SKEW	101.14
EW-6SPC	PRECAST ENDWALLS FOR MULTIPLE PIPE CULVERTS 12" - 36" PIPE 30 DEGREE SKEW	101.15
	PRECAST ENDWALLS FOR MULTIPLE PIPE CULVERTS 12" - 36" PIPE 45 DEGREE SKEW	101.16
EW-7	ENDWALLS FOR MULTIPLE PIPE CULVERTS 42" - 96" PIPE	101.17
EW-7PC	PRECAST ENDWALLS FOR MULTIPLE PIPE CULVERTS 42" - 96" PIPE	101.18
EW-7S	ENDWALLS FOR MULTIPLE PIPE CULVERTS 42" - 96" PIPE 30 DEGREE SKEW	101.19
	ENDWALLS FOR MULTIPLE PIPE CULVERTS 42" - 96" PIPE 45 DEGREE SKEW	101.20
EW-7S PC	PRECAST ENDWALLS FOR MULTIPLE PIPE CULVERTS 42" - 96" PIPE 45 DEGREE SKEW	101.21
EW-9	ENDWALLS FOR PIPE ARCHES 13" - 38" RISE	101.22
EW-9PC	PRECAST ENDWALLS FOR PIPE ARCHES 13" - 38" RISE	101.23
EW-10	ENDWALLS FOR MULTIPLE PIPE ARCHES 13" - 38" RISE	101.24
EW-10PC	PRECAST ENDWALLS FOR MULTIPLE PIPE ARCHES 13" - 38" RISE	101.25
EW-11	PIPE ENDWALL WITH LOAD-CARRYING GRATE FOR 12" - 60" PIPES	101.26
	PIPE ENDWALL WITH LOAD-CARRYING GRATE FOR 12" - 60" PIPES	101.27
	PIPE ENDWALL WITH LOAD-CARRYING GRATE FOR 12" - 60" PIPES	101.28
EW-11A	PIPE ENDWALL WITH LOAD-CARRYING GRATE FOR 12" - 24" PIPES	101.29
	PIPE ENDWALL WITH LOAD-CARRYING GRATE FOR 12" - 24" PIPES	101.30
EW-11APC	PRECAST PIPE ENDWALL WITH LOAD-CARRYING GRATE FOR 12" - 24" PIPES	101.31
EW-12	ENDWALL FOR PIPE UNDERDRAIN	101.32

INDEX OF SHEETS SECTION 100-DRAINAGE

VIRGINIA DEPARTMENT OF TRANSPORTATION

VDOT

ROAD AND BRIDGE STANDARDS

REVISION DATE

SHEET 1 OF 6

100.01

STANDARD	TITLE	PAGE
ES-1	FLARED END-SECTION FOR 12" TO 60" CONCRETE PIPE CULVERTS	102.01
ES-1A	FLARED END-SECTION FOR 23" X 14" TO 53" X 34" ELLIPTICAL CONCRETE PIPE CULVERTS	102.02
ES-2	FLARED END-SECTION FOR 12" - 60" CORRUGATED PIPE CULVERTS	102.03
ES-3	FLARED END-SECTION FOR METAL PIPE ARCHES 13"- 47" RISE	102.04
	PRECAST UNIT ASSEMBLY DIAGRAM	103.01
	LEGEND AND GENERAL NOTES - PRECAST	103.02
T-DI-1	STANDARD PRECAST TOP UNITS	103.03
T-DI-2	STANDARD PRECAST TOP UNITS	103.04
T-DI-3, 4	STANDARD PRECAST TOP UNITS	103.05
	STANDARD PRECAST TOP UNITS	103.06
T-DI-5	STANDARD PRECAST TOP UNITS	103.07
T-DI-7	STANDARD PRECAST TOP UNITS	103.08
T-MH-2	STANDARD PRECAST MANHOLE TOP UNITS	103.09
R-1, 2, 3	STANDARD PRECAST REDUCER AND RISER UNITS	103.10
B-1, 2	STANDARD PRECAST BASE UNITS	103.11
B-3	STANDARD PRECAST BASE UNITS MAX. DEPTH (H) 25'	103.12
B-4	CORRUGATED METAL TEE SECTION MAX. DEPTH (H) 25'	103.13
DI-1	STANDARD DROP INLET 12" - 24" PIPE: MAXIMUM DEPTH (H) =10'	104.01
DI-1A	STANDARD DROP INLET 12" - 24" PIPE: MAXIMUM DEPTH (H) 10' TO 20'	104.02
DI-2A, 2B, 2C	STANDARD CURB DROP INLET 12" - 24" PIPE: MAXIMUM DEPTH (H) =9'	104.03
	DIMENSIONS, NOTES, AND QUANTITIES	104.04
DI-2AA, 2BB, 2CC	STANDARD CURB DROP INLET 12" - 24" PIPE: DEPTH (H) 9' TO 20'	104.05
DI-2D, 2E, 2F	STANDARD CURB DROP INLET 30" - 48" PIPE: MAXIMUM DEPTH (H) =9'	104.06
	DIMENSIONS, NOTES, AND QUANTITIES	104.07
DI-2DD, 2EE, 2FF	STANDARD CURB DROP INLET 30" - 48" PIPE: DEPTH (H) =9' TO 20'	104.08
DI-3A, 3B, 3C	STANDARD CURB DROP INLET 12" - 30" PIPE: MAXIMUM DEPTH (H) =8'	104.09
	DIMENSIONS, NOTES, AND QUANTITIES	104.10
DI-3AA, 3BB, 3CC	STANDARD DROP INLET 12" - 30" PIPE: MAXIMUM DEPTH (H) 8' TO 20'	104.11
DI-3D, 3E, 3F	STANDARD DROP INLET (WITH UTILITY SPACE) 12" - 30" PIPE: MAXIMUM DEPTH (H) =8'	104.12
	DIMENSIONS, NOTES, AND QUANTITIES	104.13
DI-3DD, 3EE, 3FF	STANDARD CURB DROP INLET (WITH UTILITY SPACE) 12" - 30" PIPE: DEPTH (H) =8' TO 20'	104.14



ROAD AND BRIDGE STANDARDS

SHEET 2 OF 6

REVISION DATE

100.02

INDEX OF SHEETS SECTION 100-DRAINAGE

VIRGINIA DEPARTMENT OF TRANSPORTATION

STANDARD	TITLE	PAGE
DI-4A, 4B, 4C	STANDARD CURB DROP INLET 36" - 48" PIPE: MAXIMUM DEPTH (H)=8' DIMENSIONS, NOTES, AND QUANTITIES	104.15 104.16
DI-4AA, 4BB, 4CC	STANDARD CURB DROP INLET 36" - 48" PIPE: DEPTH (H) 8' TO 20'	104.17
DI-4D, 4E, 4F	STANDARD CURB DROP INLET (WITH UTILITY SPACE) 36" - 48" PIPE: MAXIMUM DEPTH (H) 8' DIMENSIONS, NOTES, AND QUANTITIES	104.18 104.19
DI-4DD, 4EE, 4FF	STANDARD CURB DROP INLET (WITH UTILITY SPACE) 36" - 48" PIPE: DEPTH (H) 8' TO 16'	104.20
DI-5	STANDARD DITCH DROP INLET	104.21
DI-7, 7A, 7B	STANDARD MEDIAN DROP INLET 12" - 42" PIPE COVER AND GUTTER DETAILS	104.22 104.23
DI-7, 7A, 7B	STANDARD DI-7, 7A OR 7B WITH FLUME CONNECTION 12" TO 36" PIPE	104.24
DI-9	15" PIPE TEE SECTION DROP INLET	104.25
DI-10G, 10H, 10I	CONCRETE MEDIAN BARRIER DROP INLET (WITH MB-7D) 12" TO 36" PIPE: DEPTH (H)=20' MAX. DIMENSIONS, NOTES, AND QUANTITIES	104.26 104.27
DI-10J, 10K, 10L	CONCRETE MEDIAN BARRIER DROP INLET (WITH MB-8A) 12" TO 24" PIPE: DEPTH (H)=20' MAX. DIMENSIONS, NOTES, AND QUANTITIES	104.28 104.29
DI-12, 12A	MULTIGRATE DROP INLET FOR PIPE SIZES 12" - 72" GRATE DETAILS DIMENSIONS, NOTES, AND QUANTITIES	104.30 104.31 104.32
DI-12B, 12C	MULTIGRATE DROP INLET FOR PIPE SIZES 12" - 36" GRATE DETAILS AND QUANTITIES	104.33 104.34
DI-13	SHOULDER SLOT INLET SHOULDER SLOT INLET	104.35 104.36
PI-1	METHOD OF OUTLET PIPE INSTALLATION FOR DI-13	104.37
DI-14A, 14B, 14C	CONCRETE MEDIAN BARRIER DROP INLET (TALL WALL WITH MB-12) 12" - 36" PIPE: DEPTH (H)=20'-0" MAX. DIMENSIONS, NOTES, AND QUANTITIES	104.38 104.39
DI-14D, 14E, 14F	CONCRETE MEDIAN BARRIER DROP INLET (TALL WALL WITH MB-13) 12" - 24" PIPE: DEPTH (H)=20'-0" MAX. CONCRETE MEDIAN BARRIER DROP INLET (TALL WALL WITH MB-13) 12" - 24" PIPE: DEPTH (H)=20'-0" MAX.	104.40 104.41
DI-MB	CONSTRUCTION METHOD FOR CONCRETE MASONRY BLOCK CURB DROP INLET	104.42
IC-2	STANDARD INLET FRAME AND COVER STANDARD INLET FRAME AND COVER PRECAST INLET FRAME AND COVER	105.01 105.02 105.03

INDEX OF SHEETS
SECTION 100-DRAINAGE
 VIRGINIA DEPARTMENT OF TRANSPORTATION



ROAD AND BRIDGE STANDARDS

REVISION DATE	SHEET 3 OF 6
---------------	--------------

100.03

STANDARD	TITLE	PAGE
MH-1	MANHOLE FOR 12" TO 48" PIPE CULVERT	106.01
	STANDARD MANHOLE FRAME AND COVER	106.02
	STANDARD MANHOLE FRAME AND COVER	106.03
	STANDARD MANHOLE FRAME AND COVER	106.04
	STANDARD MANHOLE FRAME AND COVER	106.05
MH-1A	STANDARD MANHOLE FRAME AND COVER	106.06
MH-2	PRECAST MANHOLE	106.07
IS-1	METHOD OF SHAPING MANHOLE AND INLET CULVERTS	106.08
ST-1	STANDARD STEP	106.09
JB-1	JUNCTION BOX CHAMBER DETAILS FOR 48" - 72" PIPE CULVERTS	106.10
	JUNCTION BOX DETAILS FOR ANGULAR CONNECTIONS OF 48" - 72" PIPE CULVERTS	106.11
	JUNCTION BOX TOWER DETAILS FOR 48" - 72" PIPE CULVERTS	106.12
	JUNCTION BOX DISPLACEMENT QUANTITIES FOR 48" - 72" PIPE CULVERTS	106.13
SL-1	TYPICAL CONCRETE SAFETY SLAB FOR DROP INLETS, MANHOLES AND JUNCTION BOXES	106.14
DSB-1	DRAINAGE STRUCTURE BEDDING FOR DROP INLETS, MANHOLES, AND JUNCTION BOXES	106.15
PB-1	INSTALLATION OF PIPE CULVERTS AND STORM SEWERS	107.00
	INSTALLATION OF PIPE CULVERTS AND STORM SEWERS CIRCULAR PIPE BEDDING AND BACKFILL - METHOD "A"	107.01
	INSTALLATION OF PIPE CULVERTS AND STORM SEWERS ELLIPTICAL PIPE BEDDING AND BACKFILL - METHOD "A"	107.02
	INSTALLATION OF PIPE CULVERTS AND STORM SEWERS PIPE ARCH BEDDING AND BACKFILL	107.03
	INSTALLATION OF BOX CULVERTS BEDDING AND BACKFILL	107.04
PC-1	CONCRETE PIPE - CLASS TABLE FOR HL-93 LIVE LOAD	107.05
	ELLIPTICAL CONCRETE PIPE - TABLE FOR HL-93 LIVE LOAD	107.06
	CORRUGATED STEEL PIPE - HEIGHT OF COVER TABLE FOR HL-93 LIVE LOAD	107.07
	CORRUGATED ALUMINUM ALLOY PIPE - HEIGHT OF COVER TABLE FOR HL-93 LIVE LOAD	107.08
	CORRUGATED STEEL PIPE ARCH - HEIGHT OF COVER TABLE FOR HL-93 LIVE LOAD	107.09
	CORRUGATED ALUMINUM ALLOY PIPE ARCH - HEIGHT OF COVER TABLE FOR HL-93 LIVE LOAD	107.10
	STRUCTURAL PLATE STEEL PIPE - HEIGHT OF COVER TABLE FOR HL-93 LIVE LOAD	107.11
	STRUCTURAL PLATE ALUMINUM ALLOY PIPE - HEIGHT OF COVER TABLE FOR HL-93 LIVE LOAD	107.12
	STRUCTURAL PLATE STEEL PIPE ARCH - HEIGHT OF COVER TABLE FOR HL-93 LIVE LOAD	107.13
	STRUCTURAL PLATE STEEL PIPE ARCH - HEIGHT OF COVER TABLE FOR HL-93 LIVE LOAD	107.14
	STRUCTURAL PLATE ALUMINUM ALLOY PIPE ARCH - HEIGHT OF COVER TABLE FOR HL-93 LIVE LOAD	107.15
	ALUMINUM SPIRAL RIB PIPE - HEIGHT OF COVER TABLE FOR HL-93 LIVE LOAD	107.16
	STEEL SPIRAL RIB PIPE - HEIGHT OF COVER TABLE FOR HL-93 LIVE LOAD	107.17
	CAST IRON PIPE - STRENGTH TABLE FOR HL-93 LIVE LOAD	107.18
	PLASTIC PIPE - MAXIMUM COVER TABLE FOR HL-93 LIVE LOAD	107.19
ALLOWABLE PIPE CRITERIA FOR CULVERTS AND STORM SEWERS	107.20	
ALLOWABLE PIPE CRITERIA FOR CULVERTS AND STORM SEWERS	107.21 & 107.22	



ROAD AND BRIDGE STANDARDS

SHEET 4 OF 6

REVISION DATE

100.04

11/15

INDEX OF SHEETS SECTION 100-DRAINAGE

VIRGINIA DEPARTMENT OF TRANSPORTATION

STANDARD	TITLE	PAGE
PP-1	DETAILS FOR BACKFILLING ABANDONED CULVERTS	107.23
UD-1	STANDARD GROUNDWATER UNDERDRAIN	108.01
UD-2	PIPE UNDERDRAIN FOR USE WITH RAISED GRASS MEDIAN STRIPS	108.02
UD-3	STANDARD SIDEWALK UNDERDRAIN	108.03
CD-1	STANDARD COMBINATION UNDERDRAINS (AT LOWER END OF CUTS)	108.04
CD-2	STANDARD COMBINATION UNDERDRAINS (AT GRADE SAGS AND BRIDGE APPROACHES)	108.05
UD-4	STANDARD PAVEMENT EDGEDRAIN	108.06
	STANDARD PAVEMENT EDGEDRAIN	108.07
UD-5	PREFABRICATED GEOCOMPOSITE RETROFIT PAVEMENT EDGEDRAIN	108.08
UD-7	STANDARD RETROFIT EDGEDRAIN	108.09
PG-2A	STANDARD PAVED DITCHES	109.01
PG-3	STANDARD RIPRAP AND SLOPE PROTECTION	109.02
PG-4	STANDARD PAVED FLUME FOR 12" - 24" PIPE CULVERTS	109.03
PG-5	STANDARD PAVED DITCHES	109.04
PG-6A, 6B	STANDARD PRECAST PAVED DITCHES	109.05
PG-7	DITCH FLUME CONNECTOR	109.06
SB-1	STANDARD SPRING BOX	110.01
SB-1 PC	PRECAST SPRING BOX	110.02
EG-1, 1A	STANDARD ENERGY DISSIPATOR FOR USE WITH PAVED FLUME	111.01
EG-1, 1A PC	PRECAST ENERGY DISSIPATOR	111.02
PS-2	STANDARD PIPE SPILLOUT FOR 12" - 18" PIPE CULVERTS	112.01
PS-3	STANDARD PIPE SPILLOUT FOR 21" - 30" PIPE CULVERTS	112.02
EC-1	CULVERT OUTLET PROTECTION	113.01
EC-2	PROTECTIVE COVERING INSTALLATION CRITERIA	113.02
EC-3	SOIL STABILIZATION MAT DITCH INSTALLATION TYPE A OR B	113.03
	SOIL STABILIZATION CULVERT OUTLET PROTECTION INSTALLATION	113.04
	SOIL STABILIZATION MAT SLOPE INSTALLATION TYPE C	113.05
EC-4	ROCK CHECK DAMS TYPE I AND II	113.06
EC-5	TEMPORARY SILT BARRIERS SILT FENCE (TYPE A & B) AND BRUSH BARRIER	113.07
	TEMPORARY SILT BARRIERS SILT FENCE (TYPE A & B) AND BRUSH BARRIER	113.07A
	TEMPORARY SILT BARRIERS SILT FENCE (TYPE A & B) AND BRUSH BARRIER	113.07B
	TEMPORARY SILT BARRIERS SILT FENCE (TYPE A & B) AND BRUSH BARRIER	113.08
EC-6	INLET PROTECTION (TYPE A AND B)	113.09
	INLET PROTECTION (TYPE C)	113.10

INDEX OF SHEETS
SECTION 100-DRAINAGE

VIRGINIA DEPARTMENT OF TRANSPORTATION



ROAD AND BRIDGE STANDARDS

REVISION DATE

08/14

SHEET 5 OF 6

100.05

STANDARD	TITLE	PAGE
EC-7	TYPICAL SEDIMENT TRAP	113.11
EC-8	DEWATERING BASIN	113.12
EC-9	TEMPORARY DIVERSION DIKE	113.13
EC-10	TEMPORARY BERM AND SLOPE DRAIN	113.14
EC-11	STABILIZED CONSTRUCTION ENTRANCE	113.15
EC-12	TEMPORARY DIVERSION CHANNEL	113.16
EC-13	RIPRAP WEIRS; LOW FLOW DIVERSION FOR MULTIPLE LINE CULVERTS	113.17
EC-14	TEMPORARY VEHICULAR WATERCOURSE CROSSING	113.18
SWM-1	STORMWATER MANAGEMENT DRAINAGE STRUCTURE	114.01
	PRECAST STORMWATER MANAGEMENT DRAINAGE STRUCTURE	114.02
	STORMWATER MANAGEMENT DRAINAGE STRUCTURE - GRATE DETAILS	114.03
SWM-DR	STORMWATER MANAGEMENT (SWM) DETAILS	114.04
	STORMWATER MANAGEMENT (SWM) DETAILS	114.05
	STORMWATER MANAGEMENT (SWM) DETAILS	114.06
	STORMWATER MANAGEMENT (SWM) DETAILS	114.07
	STORMWATER MANAGEMENT (SWM) DETAILS	114.08



ROAD AND BRIDGE STANDARDS

SHEET 6 OF 6

REVISION DATE

100.06

04/09

INDEX OF SHEETS SECTION 100-DRAINAGE

VIRGINIA DEPARTMENT OF TRANSPORTATION

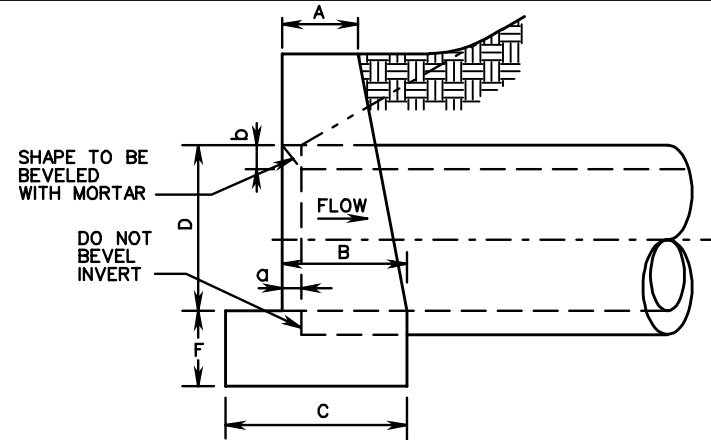
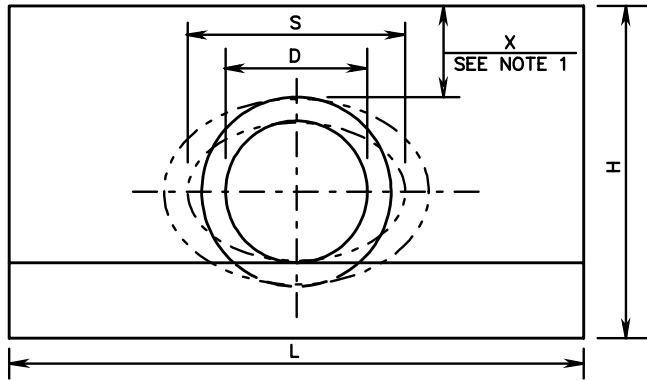

- NOTES:**
- "H" MAY BE REDUCED UNTIL "X" REACHES A MINIMUM OF 4" WHERE ENDWALL WOULD PROTRUDE ABOVE SHOULDER LINE. IN NO CASE SHALL TOP OF ENDWALL PROJECT ABOVE FILL SLOPE, DITCH SLOPE, OR SHOULDER.
 - THIS ITEM MAY BE PRECAST OR CAST IN PLACE.
 - ALL CAST IN PLACE CONCRETE TO BE CLASS A3. FOR PRECAST SEE SHEET 101.02.
 - THIS STANDARD TO BE USED WITH STRAIGHT CROSSINGS AND ALL SKEWS(0° TO 45°).
 - HEADWALL TO BE BEVELED IN ALL AREAS EXCEPT WHERE A CONFLICT WITH INVERT OR WINGWALLS OCCUR
 - BEVEL EDGE IS REQUIRED ON THE HEADWALL AT THE INLET END OF THE CULVERT (WHERE THE FLOW ENTERS THE CULVERT).
 - HEADWALL AT THE OUTLET END OF THE CULVERT MAY BE EITHER SQUARE EDGE OR BEVEL EDGE.
 - ON SHALLOW FILLS, WHERE ENDWALLS ARE 1' OR LESS BELOW SHOULDER LINE, THE TOP OF THE ENDWALL SHALL BE CONSTRUCTED PARALLEL TO THE GRADE OF THE ROAD.
 - 3/4" CHAMFER MAY BE PROVIDED ON ALL EDGES AT MANUFACTURER'S OPTION.

EW-1

ENDWALL FOR CIRCULAR PIPE

DIAMETER OF PIPE CULVERT						
	12"	15"	18"	21" OR 24"	27" OR 30"	33" OR 36"
A	0'-6"	0'-8"	0'-9"	0'-11"	1'-0"	1'-0"
B	0'-11"	1'-1"	1'-3"	1'-6"	1'-9"	2'-0"
C	1'-4"	1'-7"	1'-9"	2'-2"	2'-6"	2'-9"
D	1'-0"	1'-3"	1'-6"	2'-0"	2'-6"	3'-0"
F	0'-6"	0'-8"	0'-8"	0'-9"	0'-9"	0'-9"
H	2'-3"	2'-11"	3'-2"	3'-9"	4'-3"	4'-9"
L	4'-0"	5'-0"	6'-0"	8'-0"	10'-0"	12'-0"
a	0'-1 1/4"	0'-1 3/4"	0'-2"	0'-2 1/2"	0'-3 1/4"	0'-3 3/4"
b	0'-1"	0'-1 1/4"	0'-1 1/2"	0'-2"	0'-2 1/2"	0'-3"
CUBIC YARDS OF CONCRETE						
CONC. PIPE	0.241	0.492	0.697	1.319	2.067	2.947
C.M. PIPE	0.257	0.521	0.739	1.398	2.198	3.145

EW-1A

ENDWALL FOR ELLIPTICAL PIPE

SIZE OF ELLIPTICAL PIPE CULVERT (SPAN x RISE)								
	23"x14"	30"x19"	34"x22"	38"x24"	42"x27"	45"x29"	49"x32"	53"x34"
A	0'-8"	0'-9"	0'-10"	0'-11"	0'-11"	1'-0"	1'-0"	1'-0"
B	1'-2"	1'-5"	1'-6"	1'-8"	1'-9"	1'-10"	1'-11"	1'-11"
C	1'-8"	1'-11"	2'-1"	2'-4"	2'-5"	2'-7"	2'-8"	2'-9"
D	1'-2"	1'-7"	1'-10"	2'-0"	2'-3"	2'-5"	2'-8"	2'-10"
F	0'-8"	0'-8"	0'-9"	0'-9"	0'-9"	0'-9"	0'-9"	0'-9"
H	2'-10"	3'-3"	3'-7"	3'-9"	4'-0"	4'-2"	4'-5"	4'-7"
L	5'-5"	7'-2"	8'-6"	9'-2"	10'-2"	10'-11"	12'-1"	12'-11"
S	1'-11"	2'-6"	2'-10"	3'-2"	3'-6"	3'-9"	4'-1"	4'-5"
a	0'-2 1/2"	0'-3 1/4"	0'-3 1/2"	0'-4"	0'-4 1/2"	0'-4 3/4"	0'-5"	0'-5 1/2"
b	0'-2"	0'-2 1/2"	0'-2 3/4"	0'-3"	0'-3 1/2"	0'-3 3/4"	0'-4"	0'-4 1/2"
CUBIC YARDS OF CONCRETE								
CONC. PIPE	0.502	0.855	1.236	1.500	1.811	2.101	2.512	2.801

SPECIFICATION REFERENCE

105
302

STANDARD ENDWALL FOR PIPE CULVERTS
12" - 36" CIRCULAR AND 23" x 14" - 53" x 34" ELLIPTICAL PIPES

VIRGINIA DEPARTMENT OF TRANSPORTATION

VDOT

ROAD AND BRIDGE STANDARDS

REVISION DATE

SHEET 1 OF 1

101.01

EW-1, 1 APC

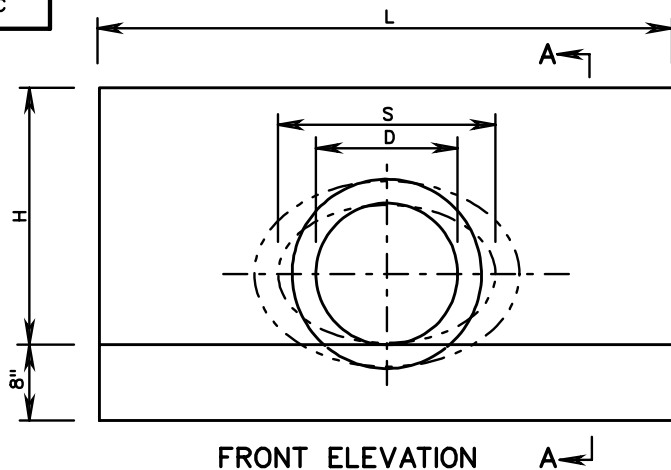

FRONT ELEVATION

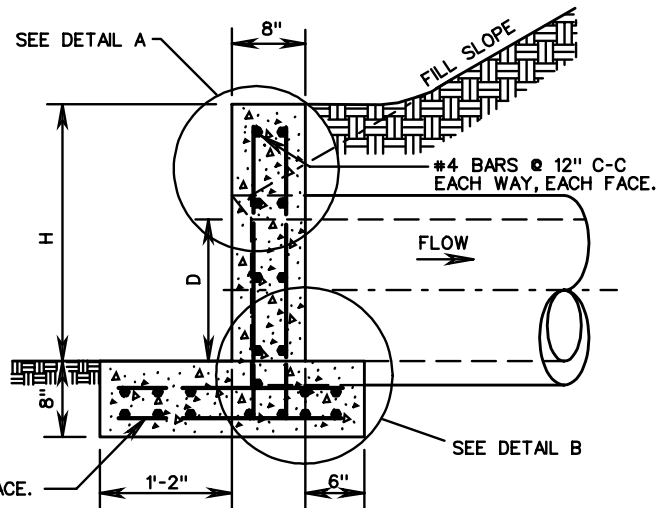

SECTION A-A

NOTES:

1. CONCRETE TO BE 4000 PSI MINIMUM COMPRESSIVE STRENGTH.
2. IF PIPE IS TO BE SKEWED THE OPENING WILL BE ADJUSTED TO ACCOMMODATE ANGLES UP TO 45°.
3. REINFORCING STEEL IN ACCORDANCE WITH ASTM A-615 (REINFORCING BARS).
4. PIPE OPENINGS IN PRECAST DRAINAGE UNITS SHALL NOT EXCEED 4 INCHES AT ANY GIVEN POINT BETWEEN THE PIPE AND THE PRECAST UNIT.
5. DIMENSIONS SHOWN ARE MINIMUM. ACTUAL MEASUREMENTS MAY VARY WITH MANUFACTURER'S TOLERANCE.
6. IN NO CASE SHALL TOP OF ENDWALL PROJECT ABOVE FILL SLOPE, DITCH SLOPE, OR SHOULDER.
7. HEADWALL TO BE BEVELED IN ALL AREAS EXCEPT WHERE A CONFLICT WITH INVERT OR WINGWALL OCCUR.
8. BEVEL EDGE IS REQUIRED ON THE HEADWALL AT THE INLET END OF THE CULVERT. HEADWALL AT OUTLET END MAY BE EITHER SQUARE EDGE OR BEVELED.
9. 3/4" CHAMFER MAY BE PROVIDED ON ALL EDGES AT MANUFACTURER'S OPTION.

#4 BARS @ 6" C-C EACH WAY, EACH FACE.

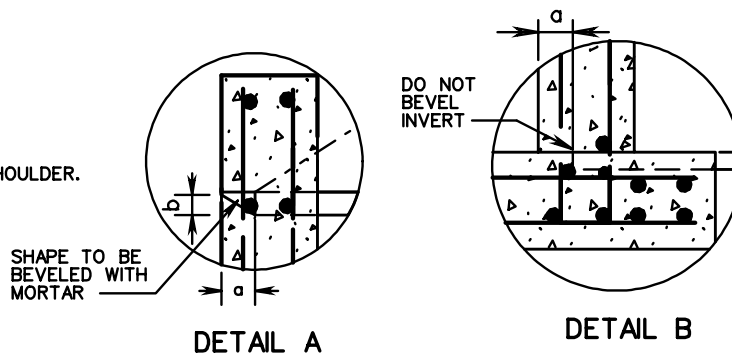

DETAIL A

DETAIL B

EW-1PC

EW-1APC

ENDWALL FOR CIRCULAR PIPE

DIAMETER OF PIPE CULVERT

D	12"	15"	18"	21" OR 24"	27" OR 30"	33" OR 36"
H	2'-0"	2'-3"	2'-6"	3'-2"	3'-10"	4'-4"
L	4'-0"	5'-0"	6'-0"	8'-0"	10'-0"	12'-0"
a	0'-1 1/4"	0'-1 3/4"	0'-2"	0'-2 1/2"	0'-3 1/4"	0'-3 3/4"
b	0'-1"	0'-1 1/4"	0'-1 1/2"	0'-2"	0'-2 1/2"	0'-3"

ENDWALL FOR ELLIPTICAL PIPE

SIZE OF ELLIPTICAL PIPE CULVERT (SPAN x RISE)

S x D	23" x 14"	30" x 19"	34" x 22"	38" x 24"	42" x 27"	45" x 29"	49" x 32"	53" x 34"
H	1'-10"	2'-4"	2'-7"	2'-9"	3'-1"	3'-3"	3'-6"	3'-8"
L	5'-5"	7'-2"	8'-6"	9'-2"	10'-2"	10'-11"	12'-1"	12'-11"
a	0'-2 1/2"	0'-3 1/4"	0'-3 1/2"	0'-4"	0'-4 1/2"	0'-4 3/4"	0'-5"	0'-5 1/2"
b	0'-2"	0'-2 1/2"	0'-2 3/4"	0'-3"	0'-3 1/2"	0'-3 3/4"	0'-4"	0'-4 1/2"



ROAD AND BRIDGE STANDARDS

PRECAST ENDWALL FOR PIPE CULVERTS

12" - 36" CIRCULAR AND 23" x 14" - 53" x 34" ELLIPTICAL PIPES

VIRGINIA DEPARTMENT OF TRANSPORTATION

SPECIFICATION REFERENCE

SHEET 1 OF 1

REVISION DATE

101.02

105
302

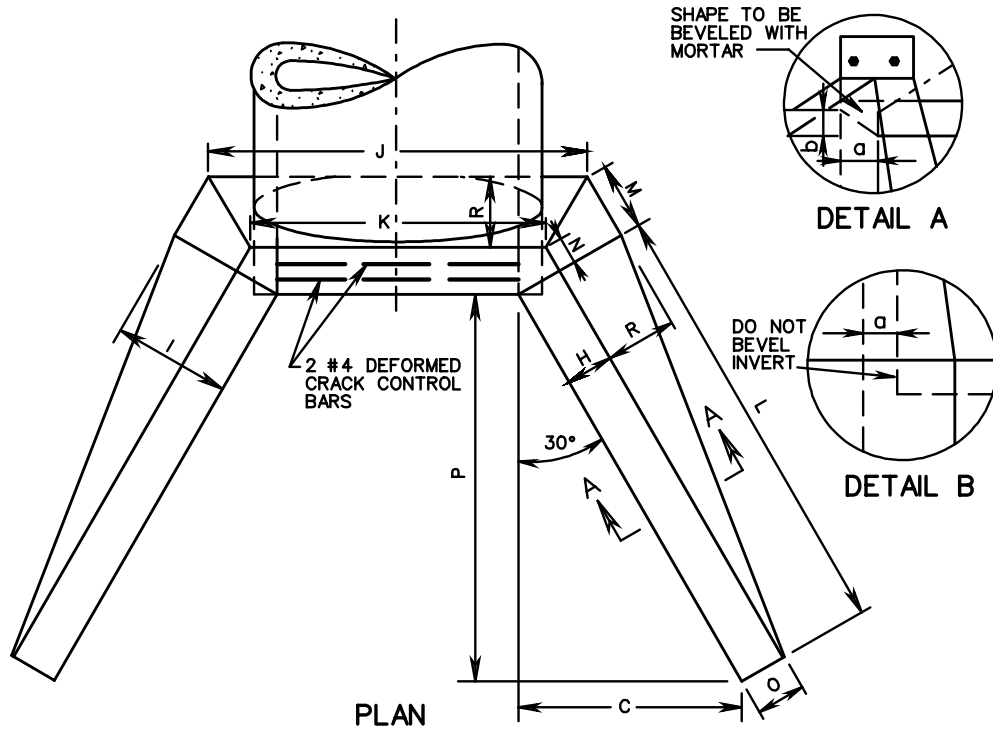

NOTES:

1. FOR TABLE OF DIMENSIONS AND VOLUMES FOR CIRCULAR PIPES (STANDARD EW-2) SEE SHEET 2 OF 3.
2. FOR TABLE OF DIMENSIONS AND VOLUMES FOR ELLIPTICAL PIPES (STANDARD EW-2A) SEE SHEET 3 OF 3.
3. THIS ITEM MAY BE PRECAST OR CAST IN PLACE.
4. ON SHALLOW FILLS, WHERE ENDWALLS ARE 1' OR LESS BELOW SHOULDER LINE, THE TOP OF THE ENDWALL SHALL BE CONSTRUCTED PARALLEL TO THE GRADE OF ROAD.
5. ALL CAST IN PLACE CONCRETE TO BE CLASS A3. FOR PRECAST SEE SHEETS 101.06 AND 101.07.
6. IN NO CASE SHALL TOP OF ENDWALL PROJECT ABOVE FILL SLOPE, DITCH SLOPE, OR SHOULDER.
7. THIS STANDARD TO BE USED WITH STRAIGHT CROSSINGS AND SKEW ANGLES TO 15°.
8. COST OF BARS FOR CRACK CONTROL TO BE INCLUDED IN PRICE PER BID PER CUBIC YARD CONCRETE.
9. HEADWALL TO BE BEVELED IN ALL AREAS EXCEPT WHERE A CONFLICT WITH INVERT AND WINGWALLS OCCUR.
10. BEVEL EDGE IS REQUIRED ON THE HEADWALL AT THE INLET END OF THE CULVERT (WHERE THE FLOW ENTERS THE CULVERT). HEADWALL AT THE OUTLET END OF THE CULVERT MAY BE EITHER SQUARE EDGE OR BEVEL EDGE.
11. 3/4" CHAMFER MAY BE PROVIDED ON ALL EDGES AT MANUFACTURER'S OPTION.

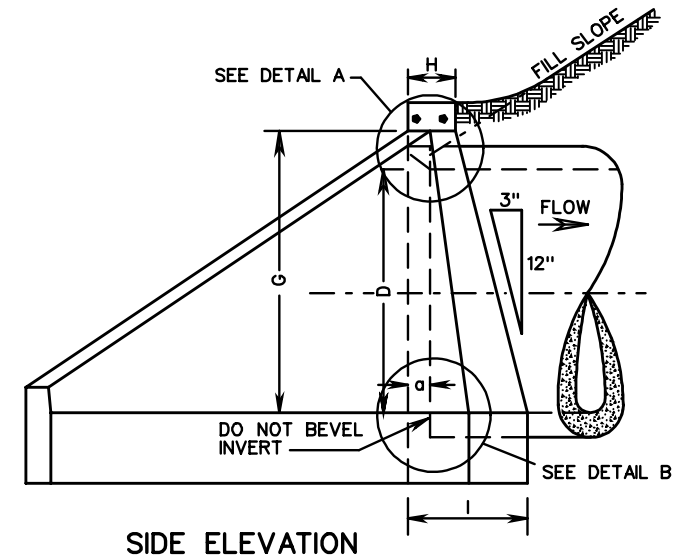
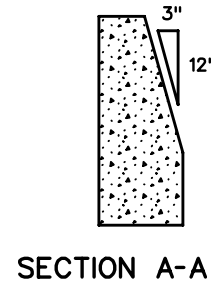
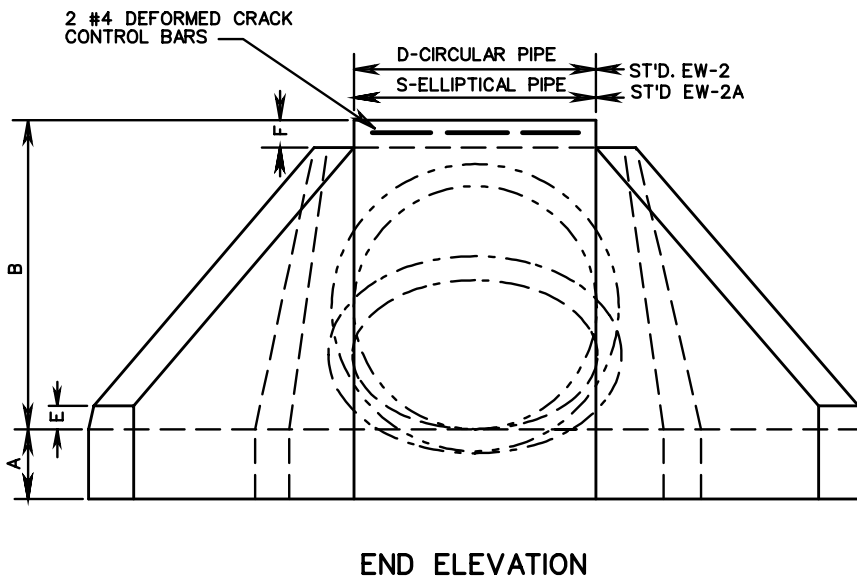

SPECIFICATION REFERENCE
105 302

STANDARD ENDWALL FOR PIPE CULVERTS
 42" - 96" CIRCULAR AND 60" x 38" - 108" x 68" ELLIPTICAL PIPES
 VIRGINIA DEPARTMENT OF TRANSPORTATION

VDOT ROAD AND BRIDGE STANDARDS	
REVISION DATE	SHEET 1 OF 3
101.03	

TABLE OF DIMENSIONS AND CONCRETE VOLUMES PER ENDWALL FOR 42" - 96" CIRCULAR PIPE CULVERTS

DIAMETER OF PIPE CULVERTS												
	DIMENSION	42"	48"	54"	60"	66"	72"	78"	84"	90"	96"	DIMENSION
FOR 1/2:1 FILL SLOPE	A	1'-6"	1'-6"	1'-6"	1'-6"	1'-6"	1'-6"	1'-6"	1'-6"	1'-6"	1'-6"	A
	B	4'-9 1/2"	5'-4"	5'-10 1/2"	6'-5"	6'-11 1/2"	7'-6"	8'-0 1/2"	8'-7"	9'-2 1/4"	9'-9 3/4"	B
	C	3'-3 3/4"	3'-9"	4'-2 1/4"	4'-7"	5'-0 5/8"	5'-5 3/4"	5'-11"	6'-4 1/4"	6'-9 3/8"	7'-2 5/8"	C
	D	3'-6"	4'-0"	4'-6"	5'-0"	5'-6"	6'-0"	6'-6"	7'-0"	7'-6"	8'-0"	D
	E	0'-6"	0'-6"	0'-6"	0'-6"	0'-6"	0'-6"	0'-6"	0'-6"	0'-6"	0'-6"	E
	F	0'-5 1/2"	0'-6"	0'-6 1/2"	0'-7"	0'-7 1/2"	0'-8"	0'-8 1/2"	0'-9"	0'-9 1/2"	0'-10"	F
	G	4'-4"	4'-10"	5'-4"	5'-10"	6'-4"	6'-10"	7'-4"	7'-10"	8'-4"	8'-10"	G
	H	0'-10"	0'-10"	0'-11"	1'-0"	1'-1"	1'-2"	1'-3"	1'-4"	1'-5"	1'-6"	H
	I	1'-11"	2'-0 1/2"	2'-3"	2'-5 1/2"	2'-8"	2'-10 1/2"	3'-1"	3'-3 1/2"	3'-6"	3'-8 1/2"	I
	J	5'-8 1/2"	6'-4 1/4"	7'-1 1/4"	7'-10"	8'-7"	9'-4"	10'-0 3/4"	10'-9 5/8"	11'-7"	12'-4 1/8"	J
	K	4'-5 1/2"	4'-11 1/2"	5'-6 3/4"	6'-1 7/8"	6'-9"	7'-4 1/8"	7'-11 1/4"	8'-6 1/2"	9'-2"	9'-9 1/8"	K
	L	6'-7 5/8"	7'-6"	8'-4 1/2"	9'-2 1/8"	10'-1 1/4"	10'-11 5/8"	11'-10"	12'-8 3/8"	13'-6 7/8"	14'-5 1/4"	L
	M	1'-1 1/4"	1'-2 1/8"	1'-3 5/8"	1'-5"	1'-6 1/2"	1'-8"	1'-9 3/8"	1'-10 3/4"	2'-0 3/8"	2'-2"	M
	N	0'-5 3/4"	0'-5 3/4"	0'-6 3/4"	0'-6 3/8"	0'-7 1/2"	0'-8 1/8"	0'-8 5/8"	0'-9 1/4"	0'-10"	0'-10 1/2"	N
	O	0'-11 1/2"	0'-11 1/2"	1'-0 1/2"	1'-1 1/2"	1'-2 1/2"	1'-3 1/2"	1'-4 1/2"	1'-5 1/2"	1'-6 1/2"	1'-7 1/2"	O
	P	5'-9"	6'-6"	7'-3"	8'-0"	8'-9"	9'-6"	10'-3"	11'-0"	11'-9"	12'-6"	P
	R	1'-1"	1'-2 1/2"	1'-4"	1'-5 1/2"	1'-7"	1'-8 1/2"	1'-10"	1'-11 1/2"	2'-1"	2'-2 1/2"	R
CUBIC YARDS CONCRETE	CONC. PIPE	3.558	4.373	5.635	7.089	8.776	10.702	12.861	15.303	18.195	21.285	CONC. PIPE
	C.M. PIPE	3.791	4.680	6.054	7.642	9.490	11.605	13.984	16.678	19.724	23.107	C.M. PIPE
FOR 2:1 FILL SLOPE	C	4'-4"	4'-10 7/8"	5'-5 3/4"	6'-0 3/4"	6'-7 5/8"	7'-2 5/8"	7'-9 1/2"	8'-4 1/2"	8'-11 3/8"	9'-6 1/4"	C
	F	0'-6 1/2"	0'-7"	0'-7 1/2"	0'-8"	0'-8 1/2"	0'-9"	0'-9 1/2"	0'-10"	0'-10 1/2"	0'-11"	F
	G	4'-3"	4'-9"	5'-3"	5'-9"	6'-3"	6'-9"	7'-3"	7'-9"	8'-3"	8'-9"	G
	I	1'-10 3/4"	2'-0 1/4"	2'-2 3/4"	2'-5 1/4"	2'-7 3/4"	2'-10 1/4"	3'-0 3/4"	3'-3 1/4"	3'-5 3/4"	3'-8 1/4"	I
	J	5'-8 1/4"	6'-4"	7'-1"	7'-9 3/4"	8'-6 3/4"	9'-3 1/2"	10'-0 1/2"	10'-9 1/8"	11'-6 3/8"	12'-3 1/2"	J
	L	8'-8"	9'-9 3/4"	10'-11 5/8"	12'-1 1/2"	13'-3 3/8"	14'-5 1/4"	15'-7"	16'-9"	17'-10 3/4"	19'-0 5/8"	L
	M	1'-1 1/8"	1'-2"	1'-3 1/2"	1'-4 7/8"	1'-6 3/8"	1'-7 3/4"	1'-9 1/4"	1'-10 5/8"	2'-0 1/4"	2'-1 1/8"	M
	P	7'-6"	8'-6"	9'-6"	10'-6"	11'-6"	12'-6"	13'-6"	14'-6"	15'-6"	16'-6"	P
	R	1'-0 3/4"	1'-2 1/4"	1'-3 3/4"	1'-5 1/4"	1'-6 3/4"	1'-8 1/4"	1'-9 3/4"	1'-11 1/4"	2'-0 3/4"	2'-2 1/4"	R
CUBIC YARDS CONCRETE	CONC. PIPE	4.238	5.230	6.761	8.538	10.602	12.958	15.612	18.623	22.104	25.898	CONC. PIPE
	C.M. PIPE	4.469	5.536	7.177	9.088	11.312	13.856	16.730	19.993	23.618	27.704	C.M. PIPE
FOR 1/2:1 AND 2:1 FILL SLOPES	a	0'-4 1/2"	0'-5"	0'-5 3/4"	0'-6 1/4"	0'-7"	0'-7 1/2"	0'-8 1/4"	0'-8 3/4"	0'-9 1/2"	0'-10"	a
	b	0'-3 1/2"	0'-4"	0'-4 1/2"	0'-5"	0'-5 1/2"	0'-6"	0'-6 1/2"	0'-7"	0'-7 1/2"	0'-8"	b

FOR ALL DIMENSIONS NOT SHOWN SEE VALUES LISTED ABOVE FOR 1/2:1 FILL SLOPE

TABLE OF DIMENSIONS AND CONCRETE VOLUMES PER ENDWALL
FOR ELLIPTICAL PIPE CULVERTS

SIZE OF ELLIPTICAL PIPE CULVERTS (SPAN X RISE)

FOR 1/2:1 FILL SLOPE	DIMENSION	60 x 38	68 x 43	76 x 48	83 x 53	91 x 58	98 x 63	106 x 68	DIMENSION	
	A	1'-6"	1'-6"	1'-6"	1'-6"	1'-6"	1'-6"	1'-6"	1'-6"	A
	B	4'-9 1/2"	4'-9 1/2"	5'-4"	5'-10 1/2"	6'-5"	6'-11 1/2"	7'-6"	B	
	C	3'-3 3/4"	3'-3 3/4"	3'-9"	4'-2 1/4"	4'-7 1/2"	5'-0 5/8"	5'-5 3/4"	C	
	D	3'-2"	3'-7"	4'-0"	4'-5"	4'-10"	5'-8"	5'-8"	D	
	E	0'-6"	0'-6"	0'-6"	0'-6"	0'-6"	0'-6"	0'-6"	E	
	F	0'-5 1/2"	0'-5 1/2"	0'-6"	0'-6 1/2"	0'-7"	0'-7 1/2"	0'-8"	F	
	G	4'-4"	4'-4"	4'-10"	5'-4"	5'-10"	6'-4"	6'-10"	G	
	H	0'-10"	0'-10"	0'-10"	0'-11"	1'-0"	1'-1"	1'-2"	H	
	I	1'-11"	1'-11"	2'-0 1/2"	2'-3"	2'-5 1/2"	2'-8"	2'-10 1/2"	I	
	J	7'-2 1/2"	7'-10 1/2"	8'-8 1/4"	9'-6 1/4"	10'-5"	11'-3"	12'-2"	J	
	K	5'-11 1/2"	6'-7 1/2"	7'-3 1/2"	7'-11 3/4"	8'-8 1/8"	9'-5"	10'-2 1/8"	K	
	L	6'-7 5/8"	6'-7 5/8"	7'-6"	8'-4 1/2"	9'-2 1/8"	10'-1 1/4"	10'-11 5/8"	L	
	M	1'-1 1/4"	1'-1 1/4"	1'-2 1/8"	1'-3 5/8"	1'-5"	1'-6 1/2"	1'-8"	M	
	N	0'-5 3/4"	0'-5 3/4"	0'-5 3/4"	0'-6 3/8"	0'-6 1/8"	0'-7 1/2"	0'-8 1/2"	N	
	O	0'-11 1/2"	0'-11 1/2"	0'-11 1/2"	1'-0 1/2"	1'-1 1/2"	1'-2 1/2"	1'-3 1/2"	O	
	P	5'-9"	5'-9"	6'-6"	7'-3"	8'-0"	8'-9"	9'-6"	P	
R	1'-1"	1'-1"	1'-2 1/2"	1'-4"	1'-5 1/2"	1'-7"	1'-8 1/2"	R		
S	5'-0"	5'-8"	6'-4"	6'-11"	7'-7"	8'-2"	8'-10"	S		
CUBIC YARDS CONCRETE	CONCRETE PIPE	3.793	3.747	4.601	5.913	7.433	9.191	11.207	CONCRETE PIPE	
FOR 2:1 FILL SLOPE	C	4'-4"	4'-4"	4'-10 7/8"	5'-5 3/4"	6'-0 3/4"	6'-7 5/8"	7'-2 5/8"	C	
	F	0'-6 1/2"	0'-6 1/2"	0'-7"	0'-7 1/2"	0'-8"	0'-8 1/2"	0'-9"	F	
	G	4'-3"	4'-3"	4'-9"	5'-3"	5'-9"	6'-3"	6'-9"	G	
	I	1'-10 3/4"	1'-10 3/4"	2'-0 1/4"	2'-2 3/4"	2'-5 1/4"	2'-7 3/4"	2'-10 1/4"	I	
	J	7'-2 1/2"	7'-10 1/2"	8'-8 1/4"	9'-6 1/4"	10'-5"	11'-3"	12'-2"	J	
	L	8'-8"	8'-8"	9'-9 3/4"	10'-11 5/8"	12'-1 1/2"	13'-3 3/8"	14'-5 1/4"	L	
	M	1'-1 1/8"	1'-1 1/8"	1'-2"	1'-3 1/2"	1'-4 7/8"	1'-6 3/8"	1'-7 3/4"	M	
	P	7'-6"	7'-6"	8'-6"	9'-6"	10'-6"	11'-6"	12'-6"	P	
R	1'-0 3/4"	1'-0 3/4"	1'-2 1/4"	1'-3 3/4"	1'-5 1/4"	1'-6 3/4"	1'-8 1/4"	R		
CUBIC YARDS CONCRETE	CONCRETE PIPE	4.469	4.423	5.453	7.034	8.876	11.010	13.457	CONCRETE PIPE	
FOR 1/2:1 AND 2:1 FILL SLOPES	a	0'-6 1/4"	0'-7"	0'-8"	0'-8 3/4"	0'-9 1/2"	0'-10 1/4"	0'-11"	a	
	b	0'-5"	0'-5 3/4"	0'-6 1/4"	0'-7"	0'-7 1/2"	0'-8"	0'-8 3/4"	b	

FOR ALL DIMENSIONS NOT SHOWN SEE VALUES LISTED ABOVE FOR 1/2:1 FILL SLOPES

SPECIFICATION
REFERENCE

105
302

STANDARD ENDWALL FOR PIPE CULVERTS
60" x 38" - 106" x 68" ELLIPTICAL PIPES
VIRGINIA DEPARTMENT OF TRANSPORTATION

VDOT
ROAD AND BRIDGE STANDARDS
REVISION DATE SHEET 3 OF 3
101.05

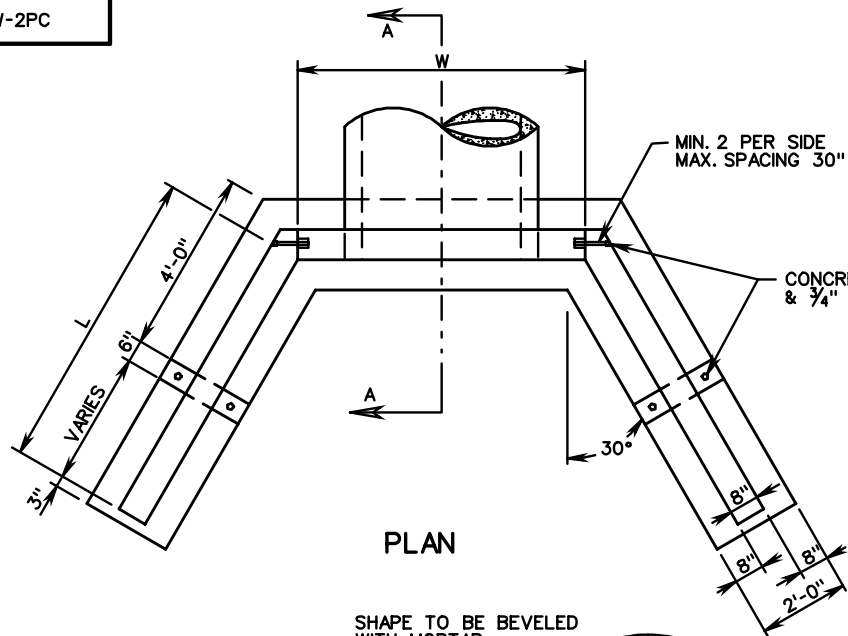

PLAN

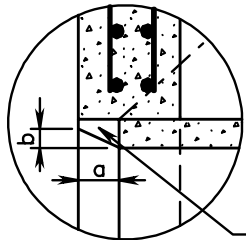

DETAIL A

SHAPE TO BE BEVELED WITH MORTAR

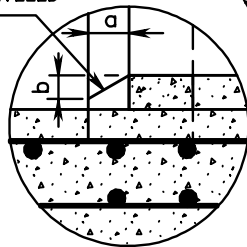

DETAIL B

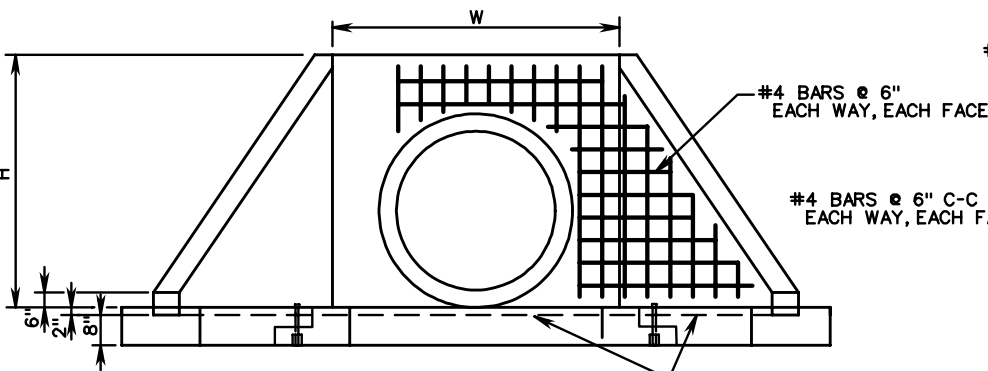

FRONT ELEVATION

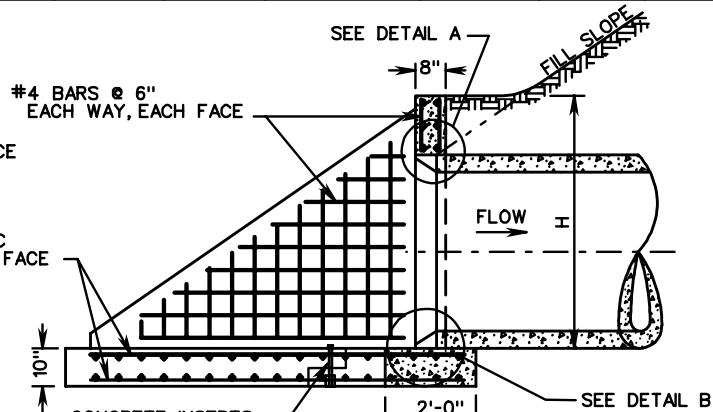

SECTION A-A

- NOTES:**
1. CONCRETE TO BE 4000 PSI MINIMUM COMPRESSIVE STRENGTH.
 2. IF PIPE IS TO BE SKEWED, THE OPENING WILL BE ADJUSTED TO ACCOMMODATE ANGLES UP TO 15°.
 3. REINFORCING STEEL IN ACCORDANCE WITH ASTM A-615 (REINFORCING BARS).
 4. PIPE OPENINGS IN PRECAST DRAINAGE UNITS SHALL NOT EXCEED 4 INCHES AT ANY GIVEN POINT BETWEEN THE PIPE AND THE PRECASTUNIT.
 5. DIMENSIONS SHOWN ARE MINIMUM. ACTUAL MEASUREMENTS MAY VARY WITH MANUFACTURER'S TOLERANCES.
 6. IN NO CASE SHALL TOP OF ENDWALL PROTRUDE ABOVE FILL SLOPE, DITCH SLOPE, OR SHOULDER.
 7. HEADWALL TO BE BEVELED IN ALL AREAS EXCEPT WHERE A CONFLICT WITH INVERT OR WINGWALL OCCUR.
 8. BEVEL EDGE AS REQUIRED ON THE HEADWALL AT THE INLET END OF THE CULVERT (WHERE THE FLOW ENTERS THE CULVERT).
 9. HEADWALL AT THE OUTLET END OF THE CULVERT MAY BE EITHER SQUARE EDGE OR BEVEL EDGE.
 10. 3/4" CHAMFER MAY BE PROVIDED ON ALL EDGES AT MANUFACTURER'S OPTION.

DIMENSIONS

D	H	W	L		a	b
			1/2:1 SLOPE	2:1 SLOPE		
42"	5'-6"	6'-3"	6'-7 1/2"	8'-8"	0'-4 1/2"	0'-3 1/2"
48"	6'-0"	6'-10"	7'-6"	9'-10"	0'-5"	0'-4"
54"	6'-6"	7'-5"	8'-4 1/2"	11'-0"	0'-5 3/4"	0'-4 1/2"
60"	7'-0"	8'-0"	9'-3"	12'-1 1/2"	0'-6 1/4"	0'-5"
66"	7'-7"	8'-8 1/2"	10'-1 1/2"	13'-3 1/2"	0'-7"	0'-5 1/2"
72"	8'-2"	9'-3 1/2"	11'-0"	14'-5 1/2"	0'-7"	0'-5 1/2"
78"	8'-8 1/2"	9'-10"	11'-10"	15'-7"	0'-7"	0'-5 1/2"
84"	9'-3"	10'-4"	12'-8 1/2"	16'-9"	0'-7"	0'-5 1/2"
90"	9'-11"	11'-1"	13'-7"	17'-11"	0'-7"	0'-5 1/2"
96"	10'-7"	11'-8"	14'-6"	19'-1"	0'-7"	0'-5 1/2"

NOTES:

1. CONCRETE TO BE 4000 PSI MINIMUM COMPRESSIVE STRENGTH.
2. IF PIPE IS TO BE SKEWED, THE OPENING WILL BE ADJUSTED TO ACCOMMODATE ANGLES UP TO 15°.
3. REINFORCING STEEL IN ACCORDANCE WITH ASTM A-615 (REINFORCING BARS).
4. PIPE OPENINGS IN PRECAST DRAINAGE UNITS SHALL NOT EXCEED 4 INCHES AT ANY GIVEN POINT BETWEEN THE PIPE AND THE PRECAST UNIT.
5. DIMENSIONS SHOWN ARE MINIMUM. ACTUAL MEASUREMENTS MAY VARY WITH MANUFACTURER'S TOLERANCES.
6. IN NO CASE SHALL TOP OF ENDWALL PROTRUDE ABOVE FILL SLOPE OR SHOULDER.
7. HEADWALL TO BE BEVELED IN ALL AREAS EXCEPT WHERE A CONFLICT WITH INVERT OR WINGWALL OCCUR.
8. BEVEL EDGE AS REQUIRED ON THE HEADWALL AT THE INLET END OF THE CULVERT (WHERE THE FLOW ENTERS THE CULVERT).
9. HEADWALL AT THE OUTLET END OF THE CULVERT MAY BE EITHER SQUARE EDGE OR BEVEL EDGE.
10. 3/4" CHAMFER MAY BE PROVIDED ON ALL EDGES AT MANUFACTURER'S OPTION.

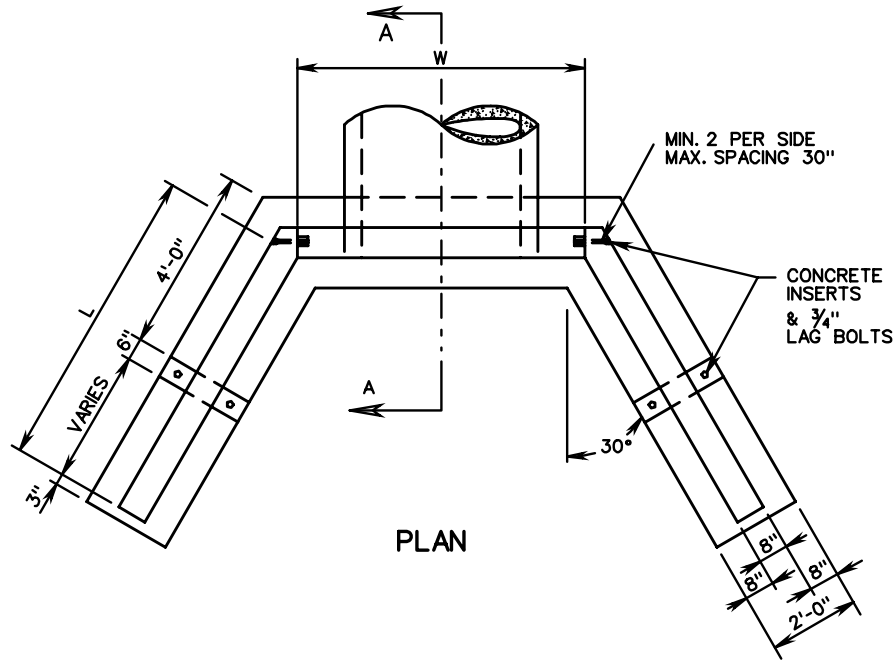

PLAN

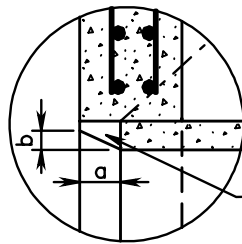

DETAIL A

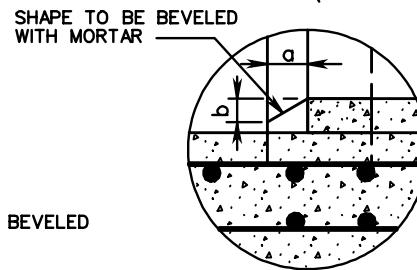

DETAIL B

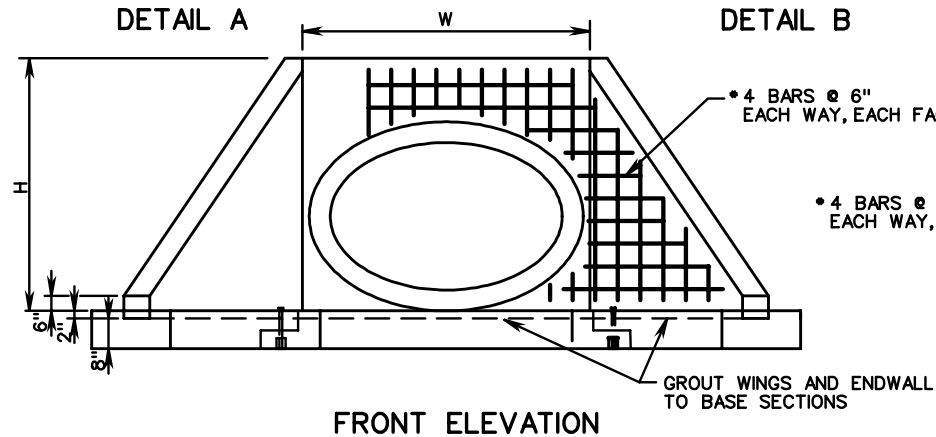

FRONT ELEVATION

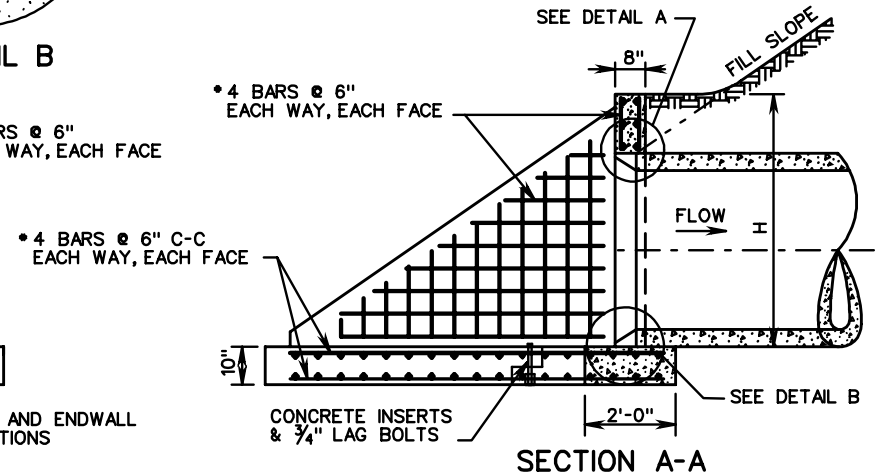

SECTION A-A

PIPE ID	H	W	L		a	b
			1/2:1 SLOPE	2:1 SLOPE		
60"x38"	5'-6"	7'-11"	6'-7 1/2"	8'-8"	0'-6 1/4"	0'-5"
68"x43"	5'-6"	8'-8"	6'-7 1/2"	8'-8"	0'-7"	0'-5 3/4"
76"x48"	6'-0"	9'-5"	7'-6"	9'-10"	0'-7"	0'-5 3/4"
83"x53"	6'-6"	10'-1"	8'-4 1/2"	11'-0"	0'-7"	0'-5 3/4"
91"x58"	7'-0"	10'-10"	9-3"	12'-1 1/2"	0'-7"	0'-5 3/4"
98"x63"	7'-7"	11'-6"	10'-1 1/2"	13'-3 1/2"	0'-7"	0'-5 3/4"
106"x68"	8'-2"	12'-3"	11'-0"	14'-5 1/2"	0'-7"	0'-5 3/4"

SPECIFICATION REFERENCE

105
302

STANDARD ENDWALL FOR PIPE CULVERTS

60" x 38" - 106" x 68" ELLIPTICAL PIPES

VIRGINIA DEPARTMENT OF TRANSPORTATION



ROAD AND BRIDGE STANDARDS

REVISION DATE

SHEET 1 OF 1

101.07

NOTES:

1. ALL DETAILS AND DIMENSIONS NOT SHOWN ARE THE SAME AS STANDARD EW-2. FOR TABLES OF DIMENSIONS AND VOLUMES SEE SHEET 2 OF 2. FOR DETAILS OF BEVEL REFER TO STANDARD EW-1, 1APC SHEET 101.02.
2. THIS ITEM MAY BE PRECAST OR CAST IN PLACE.
3. ALL CAST IN PLACE CONCRETE TO BE CLASS A3. FOR PRECAST SEE SHEET 101.10.
4. COST OF BARS FOR CRACK CONTROL TO BE INCLUDED IN PRICE BID PER CUBIC YARD CONCRETE.
5. HEADWALL TO BE BEVELED IN ALL AREAS EXCEPT WHERE A CONFLICT WITH INVERT OR WINGWALLS OCCUR.
6. BEVEL EDGE IS REQUIRED ON THE HEADWALL AT THE INLET END OF THE CULVERT (WHERE THE FLOW ENTERS THE CULVERT).
7. HEADWALL AT THE OUTLET END OF THE CULVERT MAY BE EITHER SQUARE EDGE OR BEVEL EDGE.
8. ON SHALLOW FILLS, WHERE ENDWALLS ARE 1' OR LESS BELOW SHOULDER LINE, THE TOP OF THE ENDWALL SHALL BE CONSTRUCTED PARALLEL TO THE GRADE OF THE ROAD.
9. IN NO CASE SHALL TOP OF ENDWALL PROJECT ABOVE FILL SLOPE, DITCH SLOPE, OR SHOULDER.
10. 3/4" CHAMFER MAY BE PROVIDED ON ALL EDGES AT MANUFACTURER'S OPTION.

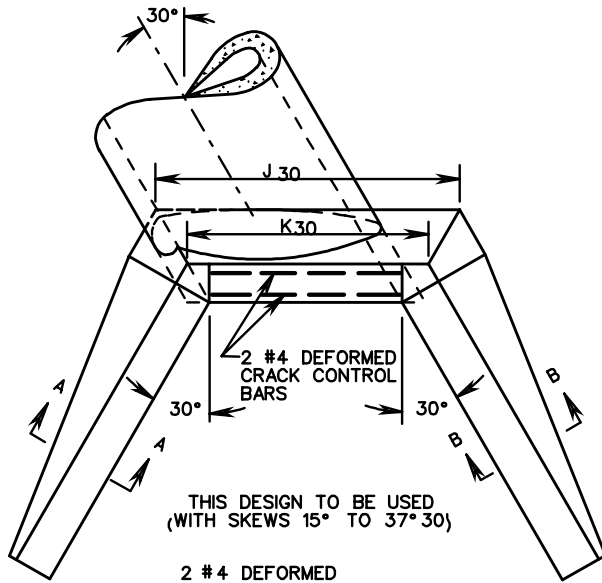

THIS DESIGN TO BE USED
(WITH SKEWS 15° TO 37° 30')

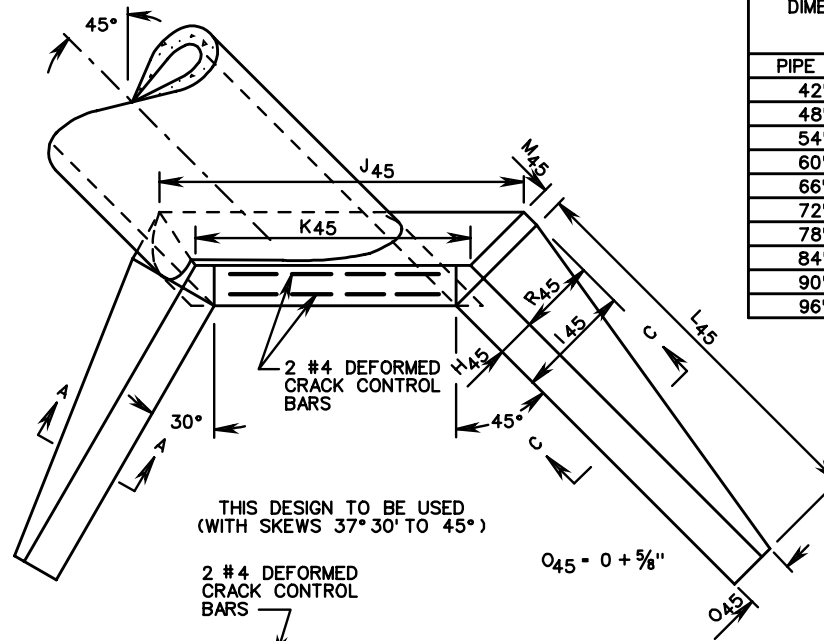

THIS DESIGN TO BE USED
(WITH SKEWS 37° 30' TO 45°)

DIMENSIONS FOR BEVEL ON HEADWALL		
PIPE I.D.	a	b
42"	0'-4 1/2"	0'-3 1/2"
48"	0'-5"	0'-4"
54"	0'-5 3/4"	0'-4 1/2"
60"	0'-6 1/4"	0'-5"
66"	0'-7"	0'-5 1/2"
72"	0'-7 1/2"	0'-6"
78"	0'-8 1/4"	0'-6 1/2"
84"	0'-8 3/4"	0'-7"
90"	0'-9 1/2"	0'-7 1/2"
96"	0'-10"	0'-8"

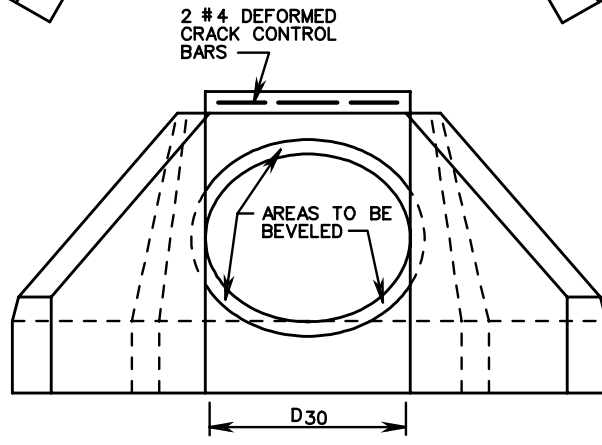

30° SKEW

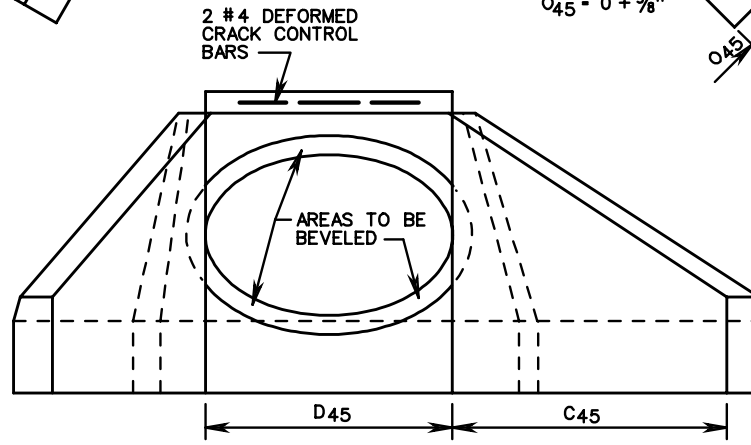

45° SKEW

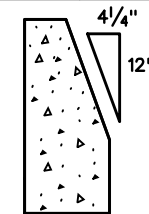

SECTION C-C

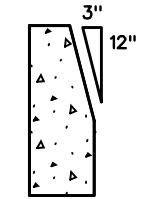

SECTION B-B

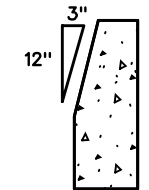

SECTION A-A



ROAD AND BRIDGE STANDARDS

STANDARD ENDWALLS FOR PIPE CULVERTS

42" - 96" CIRCULAR PIPES WITH 30° AND 45° SKEW

VIRGINIA DEPARTMENT OF TRANSPORTATION

SPECIFICATION REFERENCE

105
302

SHEET 1 OF 2

REVISION DATE

101.08

TABLE OF DIMENSIONS AND CONCRETE VOLUMES PER ENDWALL

FOR 1/2:1 FILL SLOPE

DIAMETER OF PIPE CULVERTS

30° SKEW	DIMENSION	42"	48"	54"	60"	66"	72"	78"	84"	90"	96"	DIMENSION
	D 30	4'-0 1/2"	4'-7 3/8"	5'-2 3/8"	5'-9 3/8"	6'-4 1/4"	6'-11 1/8"	7'-6 1/8"	8'-1"	8'-8"	9'-2 7/8"	D 30
	J 30	6'-3"	6'-11 5/8"	7'-9 5/8"	8'-7 3/8"	9'-5 1/4"	10'-3 1/8"	11'-0 1/8"	11'-10 1/2"	12'-8 1/2"	13'-6 1/4"	J 30
	K 30	5'-0"	5'-6 7/8"	6'-3 1/8"	6'-11 1/8"	7'-7 1/4"	8'-3 3/8"	8'-11 3/8"	9'-7 1/2"	10'-3 1/2"	10'-11 3/4"	K 30
CUBIC YARDS CONCRETE	CONC. PIPE	3.631	4.459	5.745	7.223	8.934	10.885	13.076	15.544	18.456	21.582	CONC. PIPE
	C.M. PIPE	3.900	4.814	6.228	7.861	9.758	11.928	14.373	17.132	20.221	23.686	C.M. PIPE
45° SKEW	C 45	5'-9"	6'-6"	7'-3"	8'-0"	8'-9"	9'-6"	10'-3"	11'-0"	11'-9"	12'-6"	C 45
	D 45	4'-11 3/8"	5'-7 7/8"	6'-4 3/8"	7'-0 7/8"	7'-9 3/8"	8'-5 7/8"	9'-2 1/4"	9'-10 3/4"	10'-7 1/4"	11'-3 3/4"	D 45
	I 45	2'-4 3/8"	2'-6 1/4"	2'-9 5/8"	3'-0 3/4"	3'-3 7/8"	3'-7"	3'-10 1/8"	4'-1 1/4"	4'-4 3/4"	4'-8 1/4"	I 45
	J 45	7'-5 3/4"	8'-4 5/8"	9'-4 1/2"	10'-4 3/8"	11'-4 1/4"	12'-4 1/8"	13'-3 3/8"	14'-3 1/8"	15'-4 1/8"	16'-4 1/2"	J 45
	K 45	5'-9 1/4"	6'-5 3/4"	7'-3 1/4"	8'-0 3/4"	8'-10 1/4"	9'-7 3/4"	10'-5 1/8"	11'-2 5/8"	12'-0 1/8"	12'-9 5/8"	K 45
	L 45	8'-1 9/8"	9'-2 1/4"	10'-3"	11'-3 3/4"	12'-4 1/2"	13'-5 1/4"	14'-6"	15'-6 5/8"	16'-7 1/2"	17'-8 1/8"	L 45
	M 45	0'-4 1/8"	0'-4 1/8"	0'-4 1/2"	0'-5"	0'-5 3/8"	0'-5 3/4"	0'-6 1/4"	0'-6 5/8"	0'-7"	0'-7 1/2"	M 45
	R 45	1'-6 3/8"	1'-8 1/2"	1'-10 5/8"	2'-0 3/4"	2'-2 7/8"	2'-5"	2'-7 1/8"	2'-9 1/4"	2'-11 3/4"	3'-2 1/4"	R 45
CUBIC YARDS CONCRETE	CONC. PIPE	4.231	5.191	6.712	8.447	10.441	12.714	15.276	18.150	21.420	25.107	CONC. PIPE
	C.M. PIPE	4.542	5.604	7.274	9.189	11.400	13.927	16.783	19.997	23.582	27.684	C.M. PIPE

FOR 2:1 FILL SLOPE

DIAMETER OF PIPE CULVERTS

30° SKEW		42"	48"	54"	60"	66"	72"	78"	84"	90"	96"	
	D 30	4'-0 1/2"	4'-7 3/8"	5'-2 3/8"	5'-9 3/8"	6'-4 1/4"	6'-11 1/8"	7'-6 1/8"	8'-1"	8'-8"	9'-2 7/8"	D 30
	J 30	6'-2 3/4"	6'-11 3/8"	7'-9 3/8"	8'-7 1/8"	9'-5"	10'-2 5/8"	11'-0 5/8"	11'-10 1/4"	12'-8 1/8"	13'-6"	J 30
	K 30	5'-0"	5'-6 7/8"	6'-3 1/8"	6'-11 1/8"	7'-7 1/4"	8'-3 3/8"	8'-11 3/8"	9'-7 1/2"	10'-3 1/2"	10'-11 3/4"	K 30
CUBIC YARDS CONCRETE	CONC. PIPE	4.310	5.315	6.868	8.669	10.757	13.138	15.823	18.863	22.368	26.201	CONC. PIPE
	C.M. PIPE	4.576	5.668	7.349	9.304	11.577	14.175	17.114	20.444	24.117	28.287	C.M. PIPE
45° SKEW	C 45	7'-6"	8'-6"	9'-6"	10'-6"	11'-6"	12'-6"	13'-6"	14'-6"	15'-6"	16'-6"	C 45
	D 45	4'-11 3/8"	5'-7 7/8"	6'-4 3/8"	7'-0 7/8"	7'-9 3/8"	8'-5 7/8"	9'-2 1/4"	9'-10 3/4"	10'-7 1/4"	11'-3 3/4"	D 45
	I 45	2'-4"	2'-6 1/8"	2'-9 1/4"	3'-0 3/8"	3'-3 1/2"	3'-6 5/8"	3'-9 3/4"	4'-0 1/8"	4'-4 3/8"	4'-7 7/8"	I 45
	J 45	7'-5 3/8"	8'-4 1/4"	9'-4 1/8"	10'-4"	11'-3 3/8"	12'-3 5/8"	13'-3 1/2"	14'-3 1/4"	15'-3 3/4"	16'-4"	J 45
	K 45	5'-9 1/4"	6'-5 3/4"	7'-3 1/4"	8'-0 3/4"	8'-10 1/4"	9'-7 3/4"	10'-5 1/8"	11'-2 5/8"	12'-0 1/8"	12'-9 5/8"	K 45
	L 45	10'-7 1/4"	12'-0 1/4"	13'-5 1/4"	14'-10 1/4"	16'-3 1/8"	17'-8 1/8"	19'-1 1/8"	20'-6 1/8"	21'-11"	23'-4"	L 45
	M 45	0'-4 1/8"	0'-4 1/8"	0'-4 1/2"	0'-5"	0'-5 3/8"	0'-5 3/4"	0'-6 1/4"	0'-6 5/8"	0'-6 5/8"	0'-6 3/4"	M 45
	R 45	1'-6"	1'-8 1/8"	1'-10 1/4"	2'-0 3/8"	2'-2 1/2"	2'-4 5/8"	2'-6 3/4"	2'-8 7/8"	2'-11 3/8"	3'-1 1/8"	R 45
CUBIC YARDS CONCRETE	CONC. PIPE	5.043	6.254	8.071	10.295	12.637	15.429	18.585	22.142	26.158	30.689	CONC. PIPE
	C.M. PIPE	5.351	6.664	8.629	11.033	13.590	16.635	20.086	23.981	28.298	33.241	C.M. PIPE

SPECIFICATION REFERENCE

105
302

STANDARD ENDWALLS FOR PIPE CULVERTS

42" - 96" CIRCULAR PIPES WITH 30° AND 45° SKEW

VIRGINIA DEPARTMENT OF TRANSPORTATION



ROAD AND BRIDGE STANDARDS

REVISION DATE

SHEET 2 OF 2

101.09

EW-2SPC

DIMENSIONS

ID	H	W	1/2:1 SLOPE		2:1 SLOPE		a	b
			L 30°	L 45°	L 30°	L 45°		
42"	5'-6"	8'-0"	6'-7 1/2"	8'-0"	8'-8"	10'-6"	0'-4 1/2"	0'-3 1/2"
48"	6'-0"	8'-10"	7'-6"	9'-2 1/2"	9'-9 3/4"	12'-0"	0'-5"	0'-4"
54"	6'-6"	9'-8"	8'-4 1/2"	10'-3"	10'-11 1/2"	13'-6"	0'-5 3/4"	0'-4 1/2"
60"	7'-0"	10'-6"	9'-3"	11'-3 1/2"	12'-1 1/4"	14'-10 1/4"	0'-6 1/4"	0'-5"
66"	7'-7"	11'-6"	10'-1 1/4"	12'-4 1/2"	13'-3 1/2"	16'-4"	0'-7"	0'-5 1/2"
72"	8'-2"	12'-4"	11'-0"	13'-5 1/2"	14'-5 1/2"	17'-8"	0'-7"	0'-6"
78"	8'-8 1/2"	13'-0"	11'-10"	14'-6"	15'-7"	19'-0"	0'-7"	0'-6 1/2"
84"	9'-3"	13'-10"	12'-8 1/2"	15'-6"	16'-9"	20'-6"	0'-7"	0'-7"
90"	9'-11"	14'-10"	13'-7"	16'-7 1/2"	17'-11"	21'-11"	0'-7"	0'-7 1/2"
96"	10'-7"	15'-10"	14'-5 1/4"	17'-8 1/4"	19'-1"	23'-4"	0'-7"	0'-8"

NOTES:

1. CONCRETE TO BE 4000 PSI MINIMUM COMPRESSIVE STRENGTH.
2. REINFORCING STEEL IN ACCORDANCE WITH ASTM A-615 (REINFORCING BARS).
3. PIPE OPENINGS IN PRECAST DRAINAGE UNITS SHALL NOT EXCEED 4 INCHES AT ANY GIVEN POINT BETWEEN THE PIPE AND THE PRECAST UNIT.
4. DIMENSIONS SHOWN ARE MINIMUM. ACTUAL MEASUREMENTS MAY VARY WITH MANUFACTURER'S TOLERANCES.
5. IN NO CASE SHALL TOP OF ENDWALL PROTRUDE ABOVE FILL SLOPE, DITCH SLOPE, OR SHOULDER.
6. HEADWALL TO BE BEVELED IN ALL AREAS EXCEPT WHERE A CONFLICT WITH INVERT OR WINGWALL OCCUR.
7. BEVEL EDGE AS REQUIRED ON THE HEADWALL AT THE INLET END OF THE CULVERT (WHERE THE FLOW ENTERS THE CULVERT).
8. HEADWALL AT THE OUTLET END OF THE CULVERT MAY BE EITHER SQUARE EDGE OR BEVEL EDGE.
9. 3/4" CHAMFER MAY BE PROVIDED ON ALL EDGES AT MANUFACTURER'S OPTION.

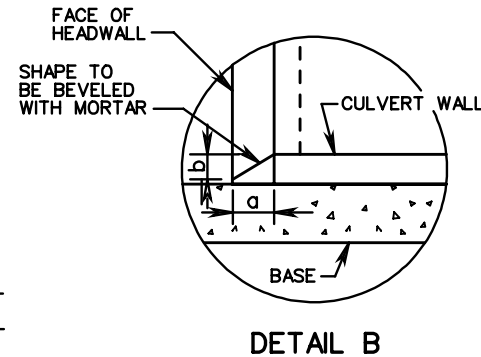
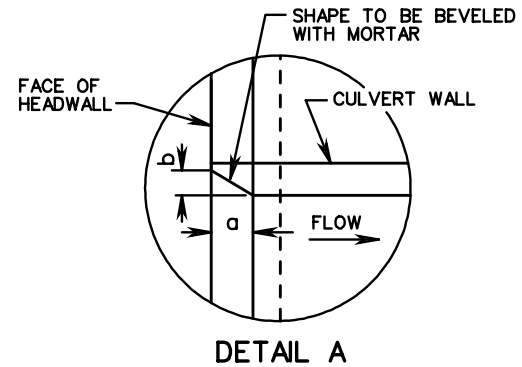
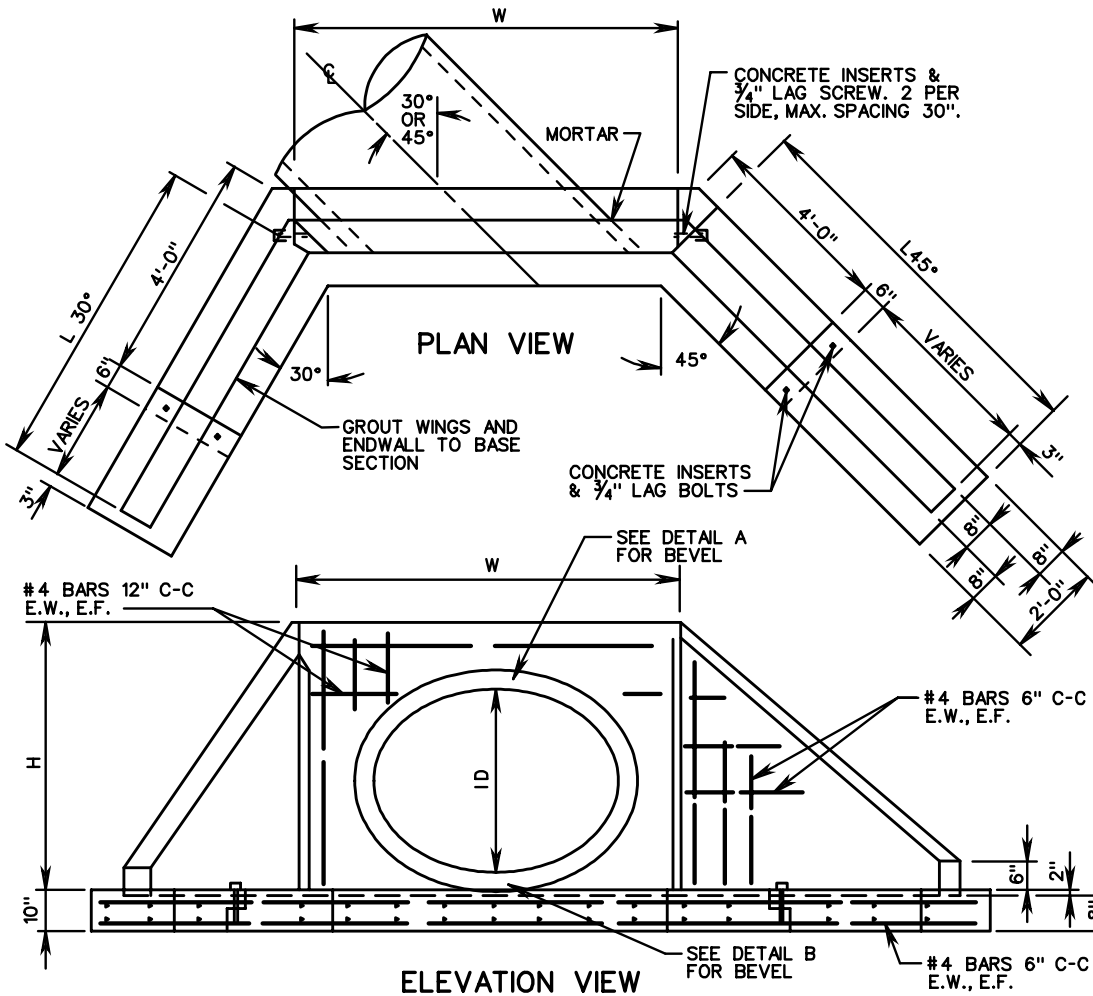

ROAD AND BRIDGE STANDARDS

SHEET 1 OF 1

REVISION DATE

101.10

PRECAST ENDWALL FOR PIPE CULVERTS

42" - 96" CIRCULAR PIPES WITH 30° AND 45° SKEW

VIRGINIA DEPARTMENT OF TRANSPORTATION

SPECIFICATION REFERENCE

105
302

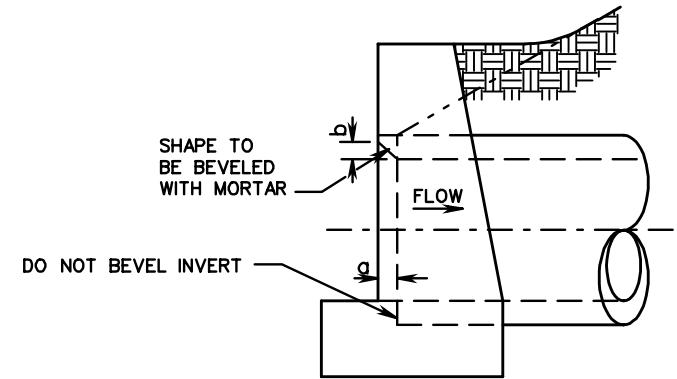
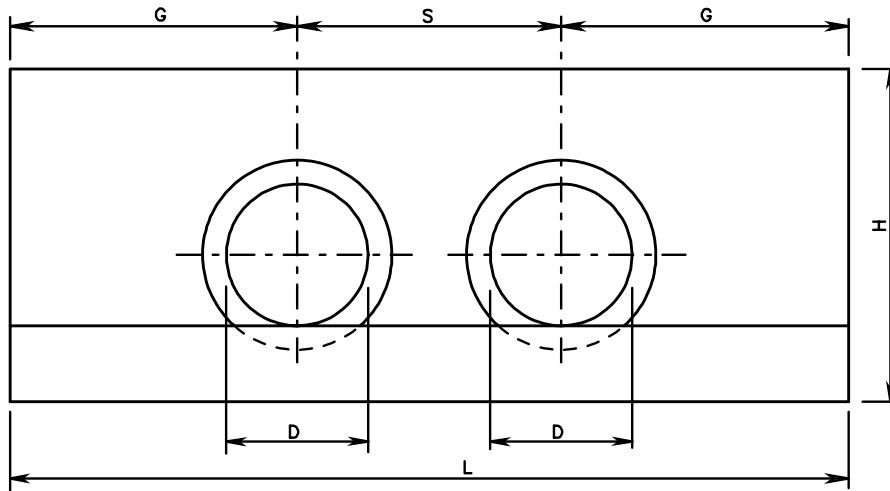

NOTES:

1. IN NO CASE SHALL TOP OF ENDWALL PROJECT ABOVE FILL SLOPE, DITCH SLOPE, DITCH SLOPE, OR SHOULDER.
2. THIS ITEM MAY BE PRECAST OR CAST IN PLACE.
3. ALL CAST IN PLACE CONCRETE TO BE CLASS A3. FOR PRECAST SEE SHEET 101.12.
4. THIS STANDARD TO BE USED WITH STRAIGHT CROSSINGS AND SKEW ANGLES TO 15°.
5. HEADWALL TO BE BEVELED IN ALL AREAS EXCEPT WHERE A CONFLICT WITH INVERT OR WINGWALLS OCCUR.
6. BEVEL EDGE IS REQUIRED ON THE HEADWALL AT THE INLET END OF THE CULVERT (WHERE THE FLOW ENTERS THE CULVERT).
7. HEADWALL AT THE OUTLET END OF THE CULVERT MAY BE EITHER SQUARE EDGE OR BEVEL EDGE.
8. ON SHALLOW FILLS, WHERE ENDWALLS ARE 1' OR LESS BELOW SHOULDER LINE, THE TOP OF THE ENDWALL SHALL BE CONSTRUCTED PARALLEL TO THE GRADE OF THE ROAD.
9. 3/4" CHAMFER MAY BE PROVIDED ON ALL EDGES AT MANUFACTURER'S OPTION.
10. QUANTITIES GIVEN ARE FOR ONE ENDWALL. PLEASE REFER TO STANDARD EW-1, SHEET 101.01 FOR ALL DIMENSIONS NOT GIVEN IN TABLES.

FOR CONCRETE PIPE							
D	S	G	L	CUBIC YARDS CONCRETE ONE DOUBLE ENDWALL	INCREASE FOR EACH ADDITIONAL PIPE	a	b
12"	1'-10"	2'-0"	5'-10"	0.329	0.088	0'-1 1/4"	0'-1"
15"	2'-3"	2'-6"	7'-3"	0.671	0.179	0'-1 3/4"	0'-1 1/4"
18"	2'-8"	3'-0"	8'-8"	0.941	0.244	0'-2"	0'-1 1/2"
21" OR 24"	3'-6"	4'-0"	11'-6"	1.763	0.444	0'-2 1/2"	0'-2"
27" OR 30"	4'-4"	5'-0"	14'-4"	2.730	0.663	0'-3 1/4"	0'-2 1/2"
33" OR 36"	5'-2"	6'-0"	17'-2"	3.854	0.907	0'-3 3/4"	0'-3"

FOR CORRUGATED METAL PIPE							
D	S	G	L	CUBIC YARDS CONCRETE ONE DOUBLE ENDWALL	INCREASE FOR EACH ADDITIONAL PIPE	a	b
12"	1'-7"	2'-0"	5'-7"	0.344	0.087	0'-1 1/4"	0'-1"
15"	1'- 11/2"	2'-6"	6'-11/2"	0.696	0.175	0'-1 3/4"	0'-1 1/4"
18"	2'-4"	3'-0"	8'-4"	0.980	0.241	0'-2"	0'-1 1/2"
24"	3'-1"	4'-0"	11'-1"	1.840	0.442	0'-2 1/2"	0'-2"
27" OR 30"	3'-10"	5'-0"	13'-10"	2.868	0.670	0'-3 1/4"	0'-2 1/2"
36"	4'-7"	6'-0"	16'-7"	4.076	0.931	0'-3 3/4"	0'-3"

SPECIFICATION REFERENCE
105 302

STANDARD ENDWALL FOR MULTIPLE PIPE CULVERTS
 12" - 36" CIRCULAR PIPES
 VIRGINIA DEPARTMENT OF TRANSPORTATION

VDOT ROAD AND BRIDGE STANDARDS	
REVISION DATE	SHEET 1 OF 1
	101.11

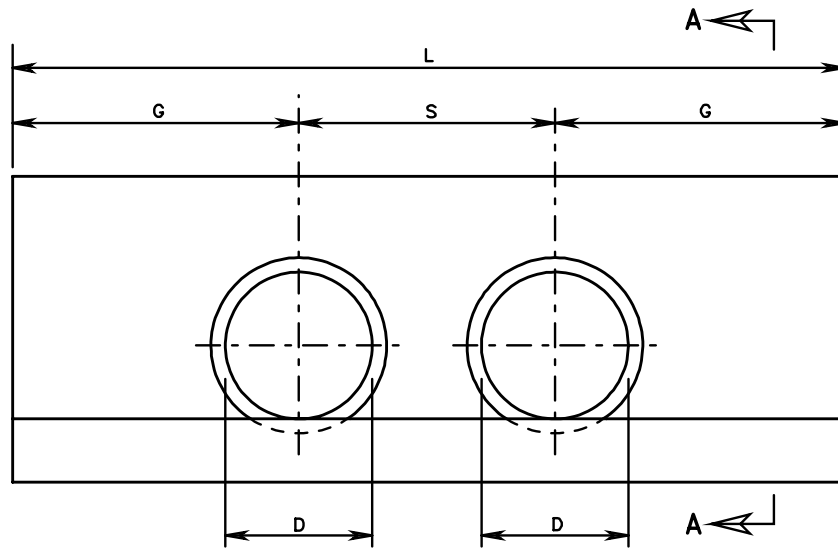

FRONT ELEVATION

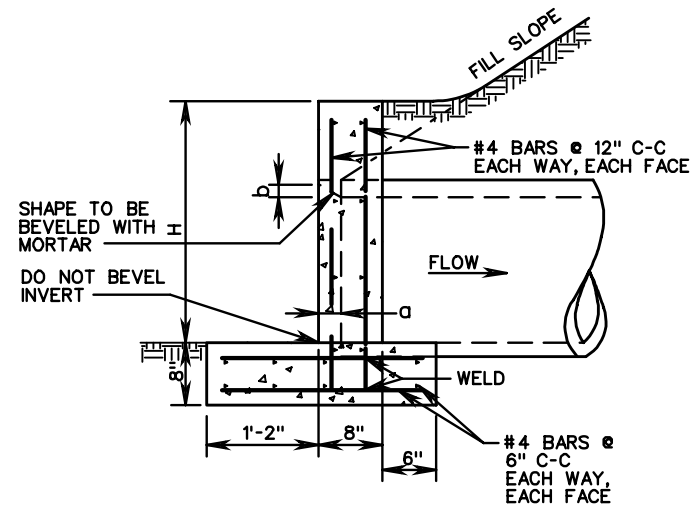

SECTION A-A

NOTES:

1. CONCRETE TO BE 4000 PSI MINIMUM COMPRESSIVE STRENGTH.
2. IF PIPE IS TO BE SKEWED THE OPENING WILL BE ADJUSTED TO ACCOMMODATE ANGLES UP TO 15°.
3. REINFORCING STEEL IN ACCORDANCE WITH ASTM A-615 (REINFORCING BARS).
4. PIPE OPENINGS IN PRECAST DRAINAGE UNITS SHALL NOT EXCEED 4 INCHES AT ANY GIVEN POINT BETWEEN THE PIPE AND THE PRECAST UNIT.
5. DIMENSIONS SHOWN ARE MINIMUM. ACTUAL MEASUREMENTS MAY VARY WITH MANUFACTURER'S TOLERANCE.
6. IN NO CASE SHALL TOP OF ENDWALL PROJECT ABOVE FILL SLOPE, DITCH SLOPE, OR SHOULDER.
7. HEADWALL TO BE BEVELED IN ALL AREAS EXCEPT WHERE A CONFLICT WITH INVERT OR WINGWALL OCCUR.
8. BEVEL EDGE IS REQUIRED ON THE HEADWALL AT THE INLET END OF THE CULVERT (WHERE THE FLOW ENTERS THE CULVERT). HEADWALL AT OUTLET END MAY BE EITHER SQUARE EDGE OR BEVELED.
9. 3/4" CHAMFER MAY BE PROVIDED ON ALL EDGES AT MANUFACTURER'S OPTION.

FOR CIRCULAR CONCRETE OR CORRUGATED METAL PIPE

FOR MULTIPLE PIPE ENDWALL

D	H	L	S	G	a	b
12"	2'-0"	5'-10"	2'-0"	1'-11"	0'-1 1/4"	0'-1"
15"	2'-3"	7'-3"	2'-3"	2'-6"	0'-1 3/4"	0'-1 1/4"
18"	2'-6"	8'-8"	2'-8"	3'-0"	0'-2"	0'-1 1/2"
21" OR 24"	3'-2"	11'-6"	3'-6"	4'-0"	0'-2 1/2"	0'-2"
27" OR 30"	3'-10"	14'-4"	4'-4"	5'-0"	0'-3 1/4"	0'-2 1/2"
33" OR 36"	4'-4"	17'-2"	5'-2"	6'-0"	0'-3 3/4"	0'-3"



ROAD AND BRIDGE STANDARDS

PRECAST ENDWALL FOR MULTIPLE PIPE CULVERTS

12" - 36" CIRCULAR PIPES

VIRGINIA DEPARTMENT OF TRANSPORTATION

SPECIFICATION REFERENCE

105
302

SHEET 1 OF 1

REVISION DATE

101.12

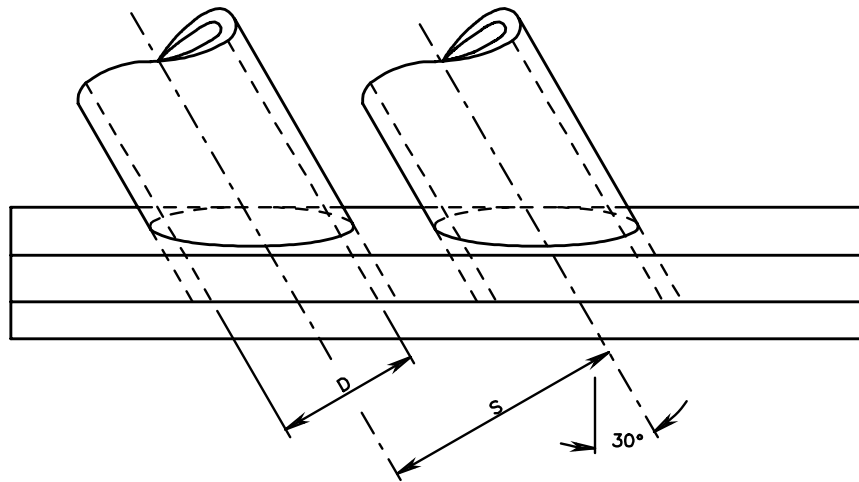

PLAN VIEW

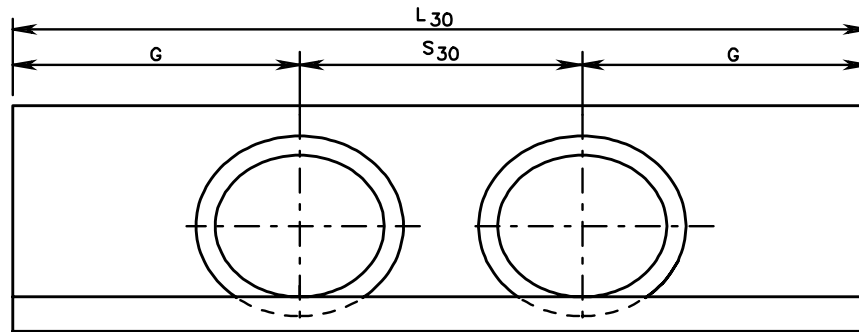

FRONT VIEW

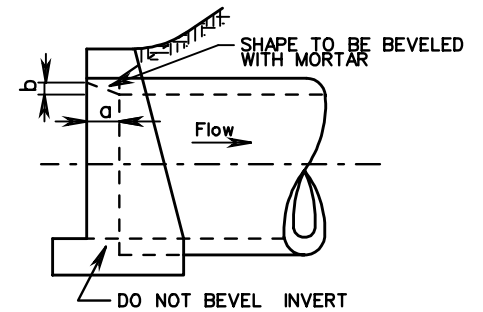

SIDE VIEW

NOTES:

1. QUANTITIES GIVEN ARE FOR ONE ENDWALL. PLEASE REFER TO STANDARD EW-1, SHEET 101.01 FOR ALL DIMENSIONS NOT GIVEN IN TABLES.
2. FOR DETAILS OF BEVEL SEE STANDARD EW-2, 2A, SHEET 101.03.
3. THIS ITEM MAY BE PRECAST OR CAST IN PLACE.
4. ON SHALLOW FILLS, WHERE ENDWALLS ARE 1' OR LESS BELOW SHOULDER LINE, THE TOP OF THE ENDWALL SHALL BE CONSTRUCTED PARALLEL TO THE GRADE OF ROAD.
5. ALL CAST IN PLACE CONCRETE TO BE CLASS A3. FOR PRECAST SEE SHEET 101.15.
6. IN NO CASE SHALL TOP OF ENDWALL PROJECT ABOVE FILL SLOPE, DITCH SLOPE, OR SHOULDER.
7. THIS STANDARD TO BE USED WITH SKEW ANGLES FROM 15° TO 37° 30'.
8. HEADWALL TO BE BEVELED IN ALL AREAS EXCEPT WHERE A CONFLICT WITH INVERT AND WINGWALLS OCCUR.
9. BEVEL EDGE IS REQUIRED ON THE HEADWALL AT THE INLET END OF THE CULVERT (WHERE THE FLOW ENTERS THE CULVERT). HEADWALL AT THE OUTLET END OF THE CULVERT MAY BE EITHER SQUARE EDGE OR BEVEL EDGE.
10. 3/4" CHAMFER MAY BE PROVIDED ON ALL EDGES AT MANUFACTURER'S OPTION.

FOR CONCRETE PIPE									
D	G	S	S ₃₀	L ₃₀	CONCRETE IN ONE DOUBLE ENDWALL CUBIC YDS.	INCREASE FOR EACH ADDITIONAL PIPE CUBIC YDS.	a	b	
12"	2'-0"	1'-10"	2'-13/8"	6'-13/8"	0.336	0.101	0'-1/4"	0'-1"	
15"	2'-6"	2'-3"	2'-7/8"	7'-7/8"	0.688	0.207	0'-1 3/4"	0'-1 1/4"	
18"	3'-0"	2'-8"	3'-1"	9'-1"	0.962	0.283	0'-2"	0'-1 1/2"	
21" OR 24"	4'-0"	3'-6"	4'-0 1/2"	12'-0 1/2"	1.794	0.512	0'-2 1/2"	0'-2"	
27" OR 30"	5'-0"	4'-4"	5'-0"	15'-0"	2.769	0.765	0'-3 1/4"	0'-2 1/2"	
33" OR 36"	6'-0"	5'-2"	5'-11 5/8"	17'-11 5/8"	3.895	1.048	0'-3 3/4"	0'-3"	

FOR CORRUGATED METAL PIPE									
D	G	S	S ₃₀	L ₃₀	CONCRETE IN ONE DOUBLE ENDWALL CUBIC YDS.	INCREASE FOR EACH ADDITIONAL PIPE CUBIC YDS.	a	b	
12"	2'-0"	1'-7"	1'-10"	5'-10"	0.354	0.100	0'-1 1/4"	0'-1"	
15"	2'-6"	1'-11 1/2"	2'-3 3/8"	7'-3 3/8"	0.714	0.201	0'-1 3/4"	0'-1 1/4"	
18"	3'-0"	2'-4"	2'-8 3/8"	8'-8 3/8"	1.005	0.278	0'-2"	0'-1 1/2"	
24"	4'-0"	3'-1"	3'-6 3/4"	11'-6 3/4"	1.882	0.510	0'-2 1/2"	0'-2"	
27" OR 30"	5'-0"	3'-10"	4'-5 5/8"	14'-5 5/8"	2.929	0.775	0'-3 1/4"	0'-2 1/2"	
36"	6'-0"	4'-7"	5'-3 1/2"	17'-3 1/2"	4.153	1.075	0'-3 3/4"	0'-3"	

SPECIFICATION REFERENCE

105
302

STANDARD ENDWALLS FOR MULTIPLE PIPE CULVERTS
12" - 36" CIRCULAR PIPES WITH 30° SKEW

VIRGINIA DEPARTMENT OF TRANSPORTATION

VDOT

ROAD AND BRIDGE STANDARDS

REVISION DATE

SHEET 1 OF 2

101.13

NOTES:

1. QUANTITIES GIVEN ARE FOR ONE ENDWALL. PLEASE REFER TO STANDARD EW-1, SHEET 101.01 FOR ALL DIMENSIONS NOT GIVEN IN TABLES.
2. FOR DETAILS OF BEVEL SEE STANDARD EW-2, 2A, SHEET 101.03.
3. THIS ITEM MAY BE PRECAST OR CAST IN PLACE.
4. ON SHALLOW FILLS, WHERE ENDWALLS ARE 1' OR LESS BELOW SHOULDER LINE, THE TOP OF THE ENDWALL SHALL BE CONSTRUCTED PARALLEL TO THE GRADE OF ROAD.
5. ALL CAST IN PLACE CONCRETE TO BE CLASS A3. FOR PRECAST SEE SHEET 101.16.
6. IN NO CASE SHALL TOP OF ENDWALL PROJECT ABOVE FILL SLOPE, DITCH SLOPE, OR SHOULDER.
7. THIS STANDARD TO BE USED WITH SKEW ANGLES FROM 37° 30' TO 45°.
8. HEADWALL TO BE BEVELED IN ALL AREAS EXCEPT WHERE A CONFLICT WITH INVERT AND WINGWALLS OCCUR.
9. BEVEL EDGE IS REQUIRED ON THE HEADWALL AT THE INLET END OF THE CULVERT (WHERE THE FLOW ENTERS THE CULVERT). HEADWALL AT THE OUTLET END OF THE CULVERT MAY BE EITHER SQUARE EDGE OR BEVEL EDGE.
10. 3/4" CHAMFER MAY BE PROVIDED ON ALL EDGES AT MANUFACTURER'S OPTION.

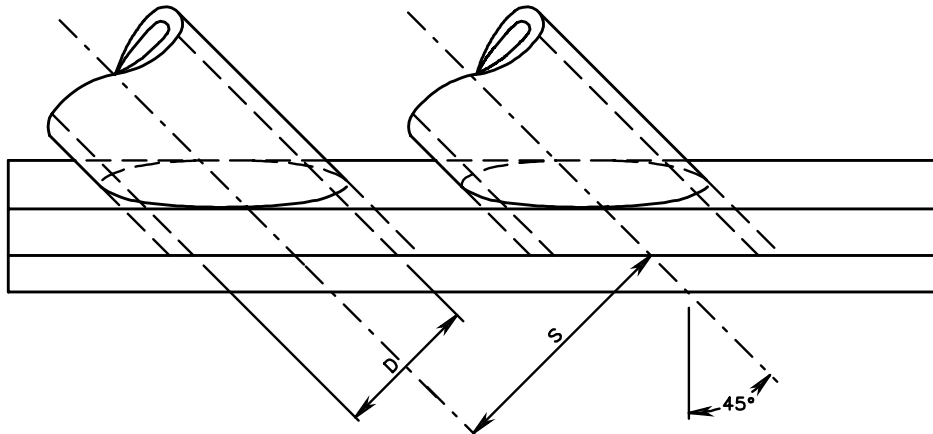

PLAN VIEW

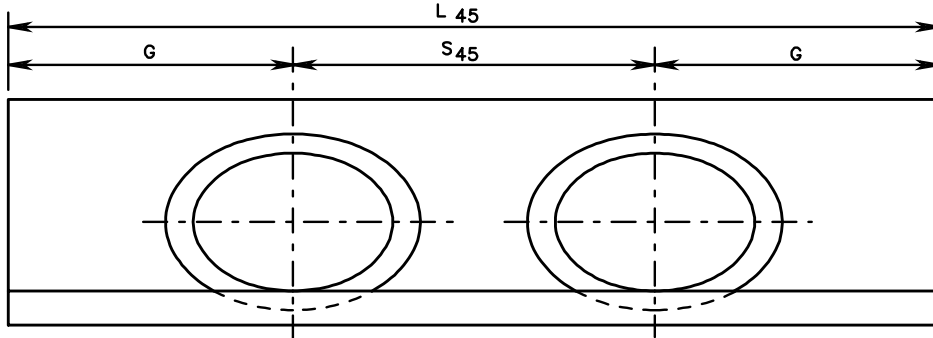

FRONT VIEW

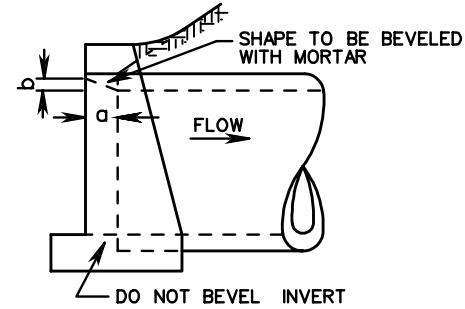

SIDE VIEW

FOR CONCRETE PIPE

D	G	S	S ₄₅	L ₄₅	CONCRETE IN ONE DOUBLE ENDWALL CUBIC YDS.	INCREASE FOR EACH ADDITIONAL PIPE CUBIC YDS.	a	b
12"	2'-0"	1'-10"	2'-7 ¹ / ₈ "	6'-7 ¹ / ₈ "	0.350	0.125	0'-1 ¹ / ₄ "	0'-1"
15"	2'-6"	2'-3"	3'-2 ¹ / ₈ "	8'-2 ¹ / ₈ "	0.714	0.235	0'-1 ³ / ₄ "	0'-1 ¹ / ₄ "
18"	3'-0"	2'-8"	3'-9 ¹ / ₄ "	9'-9 ¹ / ₄ "	0.995	0.346	0'-2"	0'-1 ¹ / ₂ "
21" OR 24"	4'-0"	3'-6"	4'-11 ³ / ₈ "	12'-11 ³ / ₈ "	1.846	0.626	0'-2 ¹ / ₂ "	0'-2"
27" OR 30"	5'-0"	4'-4"	6'-1 ¹ / ₂ "	16'-1 ¹ / ₂ "	2.834	0.937	0'-3 ¹ / ₄ "	0'-2 ¹ / ₂ "
33" OR 36"	6'-0"	5'-2"	7'-3 ⁵ / ₈ "	19'-3 ⁵ / ₈ "	3.966	1.281	0'-3 ³ / ₄ "	0'-3"

FOR CORRUGATED METAL PIPE

D	G	S	S ₄₅	L ₄₅	CONCRETE IN ONE DOUBLE ENDWALL CUBIC YDS.	INCREASE FOR EACH ADDITIONAL PIPE CUBIC YDS.	a	b
12"	2'-0"	1'-7"	2'-2 ⁷ / ₈ "	6'-2 ⁷ / ₈ "	0.369	0.122	0'-1 ¹ / ₄ "	0'-1"
15"	2'-6"	1'-11 ¹ / ₂ "	2'-9 ¹ / ₄ "	7'-9 ¹ / ₄ "	0.746	0.246	0'-1 ³ / ₄ "	0'-1 ¹ / ₄ "
18"	3'-0"	2'-4"	3'-3 ⁵ / ₈ "	9'-3 ⁵ / ₈ "	1.047	0.340	0'-2"	0'-1 ¹ / ₂ "
24"	4'-0"	3'-1"	4'-4 ³ / ₈ "	12'-4 ³ / ₈ "	1.956	0.625	0'-2 ¹ / ₂ "	0'-2"
27" OR 30"	5'-0"	3'-10"	5'-5"	15'-5"	3.030	0.948	0'-3 ¹ / ₄ "	0'-2 ¹ / ₂ "
36"	6'-0"	4'-7"	6'-5 ³ / ₄ "	18'-5 ³ / ₄ "	4.280	1.316	0'-3 ³ / ₄ "	0'-3"



ROAD AND BRIDGE STANDARDS

STANDARD ENDWALLS FOR MULTIPLE PIPE CULVERTS

12" - 36" CIRCULAR PIPES WITH 45° SKEW

VIRGINIA DEPARTMENT OF TRANSPORTATION

SPECIFICATION REFERENCE

105
302

SHEET 2 OF 2

REVISION DATE

101.14

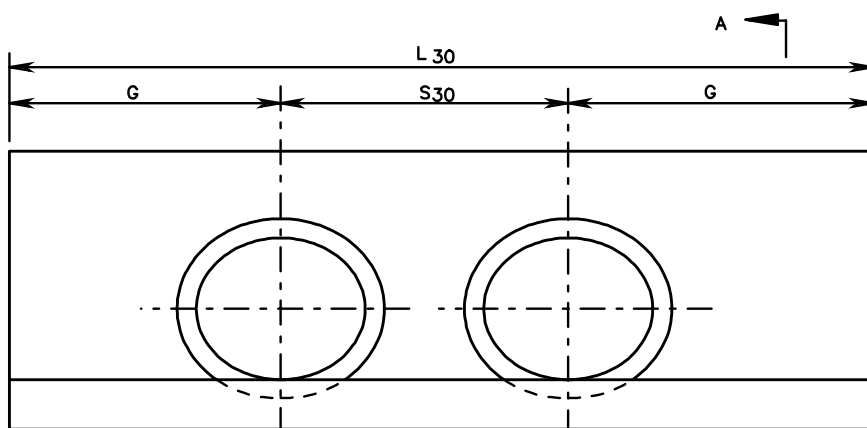
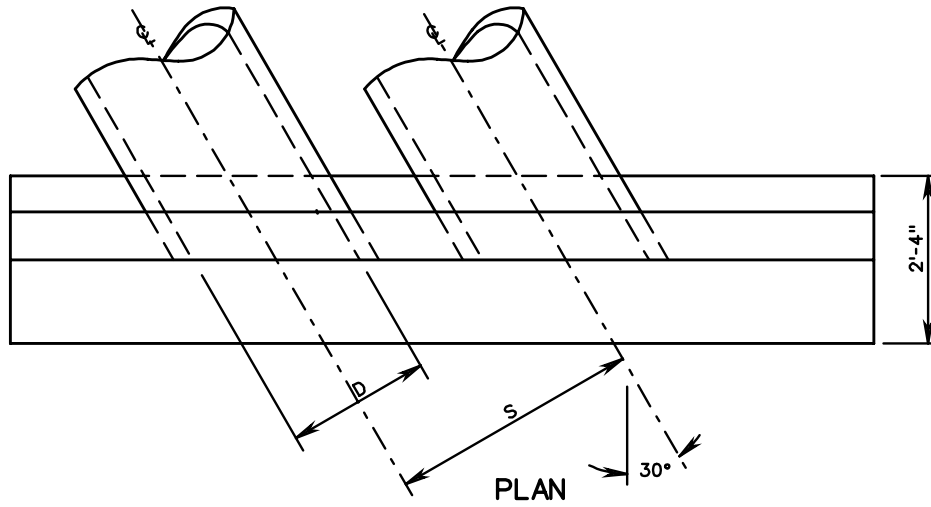

FRONT ELEVATION

FOR CIRCULAR CONCRETE OR CORRUGATED METAL PIPE							
FOR MULTIPLE PIPE ENDWALL							
DIAMETER D OF PIPE	H	L30	S	S30	G	a	b
12"	2'-0"	6'-1 ¹ / ₈ "	1'-10"	2'-1 ¹ / ₈ "	2'-0"	0'-1 ¹ / ₄ "	0'-1"
15"	2'-3"	7'-7 ¹ / ₈ "	2'-3"	2'-7 ¹ / ₈ "	2'-6"	0'-1 ¹ / ₄ "	0'-1 ¹ / ₄ "
18"	2'-6"	9'-1"	2'-8"	3'-1"	3'-0"	0'-2"	0'-1 ¹ / ₂ "
21" OR 24"	3'-2"	12'-0 ¹ / ₂ "	3'-6"	4'-0 ¹ / ₂ "	4'-0"	0'-2 ¹ / ₂ "	0'-2"
27" OR 30"	3'-10"	15'-0"	4'-4"	5'-0"	5'-0"	0'-3 ¹ / ₄ "	0'-2 ¹ / ₂ "
33" OR 36"	4'-4"	17'-11 ¹ / ₈ "	5'-2"	5'-11 ¹ / ₈ "	6'-0"	0'-3 ³ / ₄ "	0'-3"

NOTES:

1. CONCRETE TO BE 4000 PSI MINIMUM COMPRESSIVE STRENGTH.
2. IF PIPE IS TO SKEWED THE OPENING WILL BE ADJUSTED TO ACCOMMODATE ANGLES OF 15° TO 37° 30'.
3. REINFORCING STEEL IN ACCORDANCE WITH ASTM A-615 (REINFORCING BARS).
4. PIPE OPENINGS IN PRECAST DRAINAGE UNITS SHALL NOT EXCEED 4 INCHES AT ANY GIVEN POINT BETWEEN THE PIPE AND THE PRECAST UNIT.
5. DIMENSIONS SHOWN ARE MINIMUM. ACTUAL MEASUREMENTS MAY VARY WITH MANUFACTURER'S TOLERANCE.
6. IN NO CASE SHALL TOP OF ENDWALL PROJECT ABOVE FILL SLOPE, DITCH SLOPE, OR SHOULDER.
7. HEADWALL TO BE BEVELED IN ALL AREAS EXCEPT WHERE A CONFLICT WITH INVERT OR WINGWALL OCCUR.
8. BEVEL EDGE IS REQUIRED ON THE HEADWALL AT THE INLET END OF THE CULVERT (WHERE THE FLOW ENTERS THE CULVERT). HEADWALL AT OUTLET END MAY BE EITHER SQUARE EDGE OR BEVELED.
9. 3/4" CHAMFER MAY BE PROVIDED ON ALL EDGES AT MANUFACTURER'S OPTION.

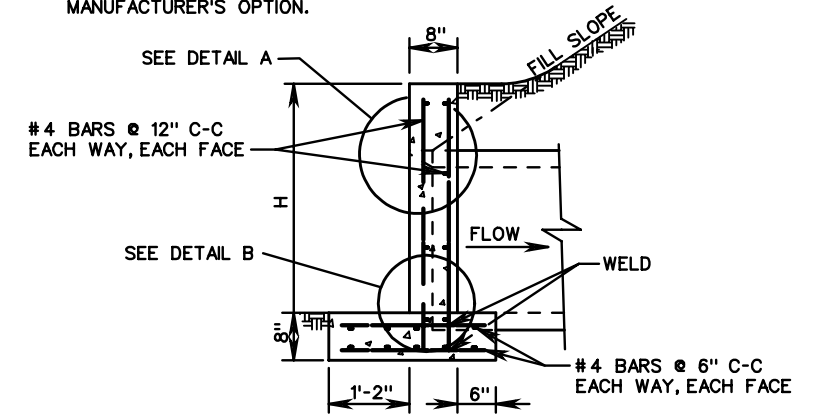

SECTION A-A

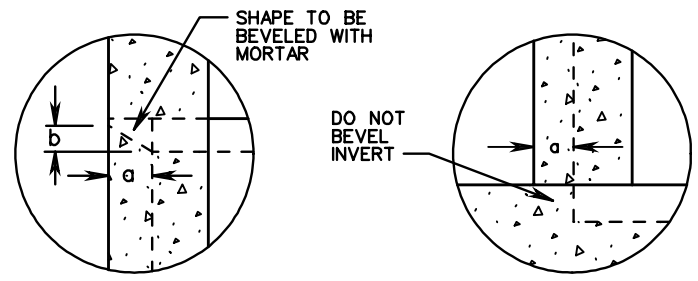

DETAIL A

DETAIL B

SPECIFICATION REFERENCE

105
302

PRECAST ENDWALL FOR MULTIPLE PIPE CULVERTS
12" - 36" CIRCULAR PIPES WITH 30° SKEW

VIRGINIA DEPARTMENT OF TRANSPORTATION



ROAD AND BRIDGE STANDARDS

REVISION DATE

SHEET 1 OF 1

101.15

NOTES:

1. CONCRETE TO BE 4000 PSI MINIMUM COMPRESSIVE STRENGTH.
2. IF PIPE IS TO SKEWED THE OPENING WILL BE ADJUSTED TO ACCOMMODATE ANGLES OF 37° 30' TO 45°.
3. REINFORCING STEEL IN ACCORDANCE WITH ASTM A-615 (REINFORCING BARS).
4. PIPE OPENINGS IN PRECAST DRAINAGE UNITS SHALL NOT EXCEED 4 INCHES AT ANY GIVEN POINT BETWEEN THE PIPE AND THE PRECAST UNIT.
5. DIMENSIONS SHOWN ARE MINIMUM. ACTUAL MEASUREMENTS MAY VARY WITH MANUFACTURER'S TOLERANCE.
6. IN NO CASE SHALL TOP OF ENDWALL PROJECT ABOVE FILL SLOPE, DITCH SLOPE, OR SHOULDER.
7. HEADWALL TO BE BEVELED IN ALL AREAS EXCEPT WHERE A CONFLICT WITH INVERT OR WINGWALL OCCUR.
8. BEVEL EDGE IS REQUIRED ON THE HEADWALL AT THE INLET END OF THE CULVERT (WHERE THE FLOW ENTERS THE CULVERT). HEADWALL AT OUTLET END MAY BE EITHER SQUARE EDGE OR BEVELED.
9. 3/4" CHAMFER MAY BE PROVIDED ON ALL EDGES AT MANUFACTURER'S OPTION.

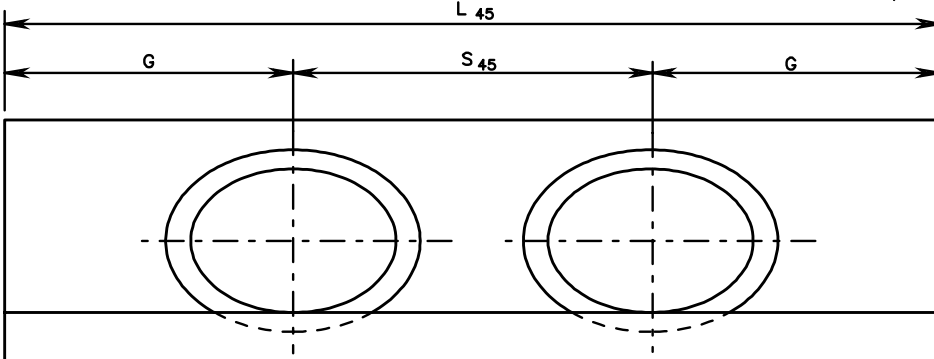
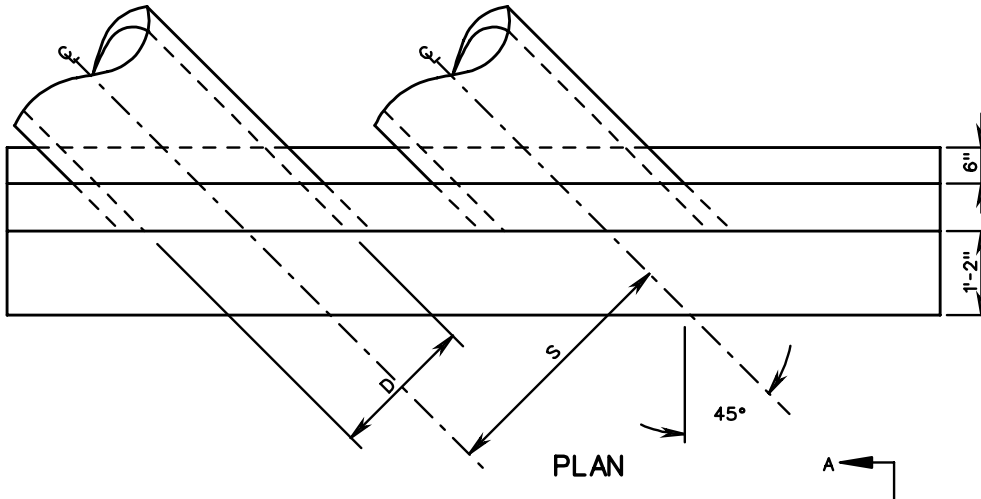

FRONT ELEVATION

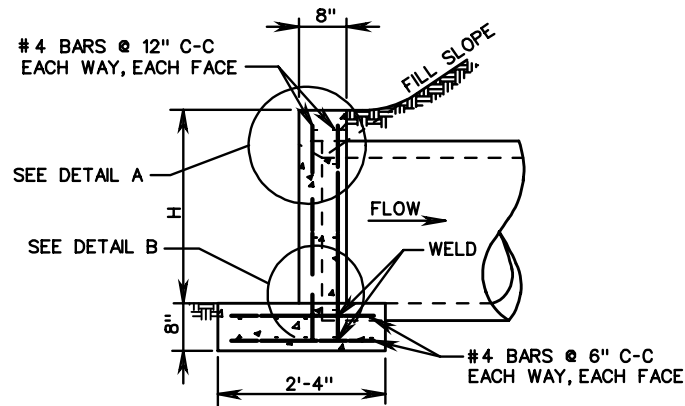

SECTION A-A

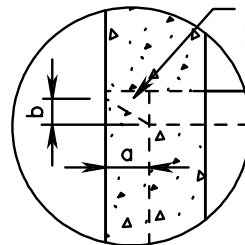

DETAIL A

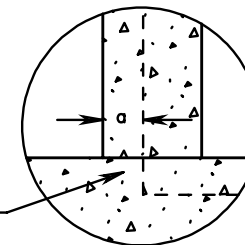

DETAIL B

FOR CIRCULAR CONCRETE OR CORRUGATED METAL PIPE

FOR MULTIPLE PIPE ENDWALL

D	H	L45	S	S45	G	a	b
12"	2'-0"	6'-7 ¹ / ₈ "	1'-10"	2'-7 ¹ / ₈ "	2'-0"	0'-1 ¹ / ₄ "	0'-1"
15"	2'-3"	8'-2 ¹ / ₈ "	2'-3"	3'-2 ¹ / ₈ "	2'-6"	0'-1 ³ / ₄ "	0'-1 ¹ / ₄ "
18"	2'-6"	9'-9 ¹ / ₄ "	2'-8"	3'-9 ¹ / ₄ "	3'-0"	0'-2"	0'-1 ¹ / ₂ "
21" OR 24"	3'-2"	12'-11 ³ / ₈ "	3'-6"	4'-11 ³ / ₈ "	4'-0"	0'-2 ¹ / ₂ "	0'-2"
27" OR 30"	3'-10"	16'-1 ¹ / ₂ "	4'-4"	6'-1 ¹ / ₂ "	5'-0"	0'-3 ¹ / ₄ "	0'-2 ¹ / ₂ "
33" OR 36"	4'-4"	19'-3 ⁵ / ₈ "	5'-2"	7'-3 ⁵ / ₈ "	6'-0"	0'-4 ¹ / ₂ "	0'-3"



ROAD AND BRIDGE STANDARDS

PRECAST ENDWALL FOR MULTIPLE PIPE CULVERTS

12" - 36" CIRCULAR PIPES FOR 45° SKEW

VIRGINIA DEPARTMENT OF TRANSPORTATION

SPECIFICATION REFERENCE

SHEET 1 OF 1

REVISION DATE

101.16

105
302

NOTES:

1. QUANTITIES GIVEN ARE FOR ONE ENDWALL.
2. PLEASE REFER TO STANDARD EW-2, SHEET 101.04, FOR ALL DIMENSIONS NOT GIVEN IN TABLES.
3. THIS ITEM MAY BE PRECAST OR CAST IN PLACE.
4. ON SHALLOW FILLS, WHERE ENDWALLS ARE 1' OR LESS BELOW SHOULDER LINE, THE TOP OF THE ENDWALL SHALL BE CONSTRUCTED PARALLEL TO THE GRADE OF ROAD.
5. ALL CAST IN PLACE CONCRETE TO BE CLASS A3. FOR PRECAST SEE SHEET 101.18.
6. IN NO CASE SHALL TOP OF ENDWALL PROJECT ABOVE FILL SLOPE, DITCH SLOPE, OR SHOULDER.
7. THIS STANDARD TO BE USED WITH STRAIGHT CROSSINGS AND SKEW ANGLES TO 15°.
8. COST OF BARS FOR CRACK CONTROL TO BE INCLUDED IN PRICE PER BID PER CUBIC YARD CONCRETE.
9. HEADWALL TO BE BEVELED IN ALL AREAS EXCEPT WHERE A CONFLICT WITH INVERT AND WINGWALLS OCCUR.
10. BEVEL EDGE IS REQUIRED ON THE HEADWALL AT THE INLET END OF THE CULVERT (WHERE THE FLOW ENTERS THE CULVERT). HEADWALL AT THE OUTLET END OF THE CULVERT MAY BE EITHER SQUARE EDGE OR BEVEL EDGE.
11. 3/4" CHAMFER MAY BE PROVIDED ON ALL EDGES AT MANUFACTURER'S OPTION.

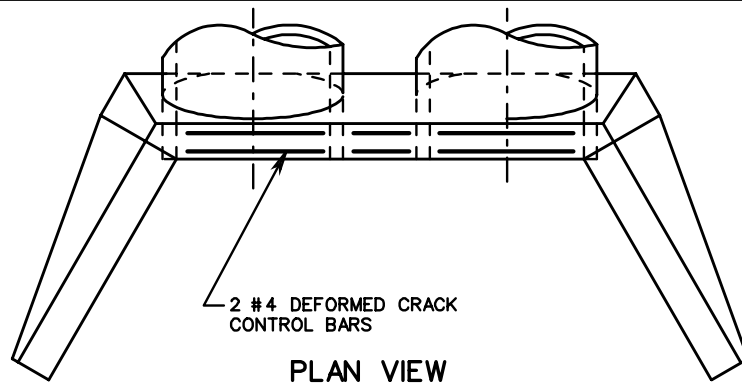

PLAN VIEW

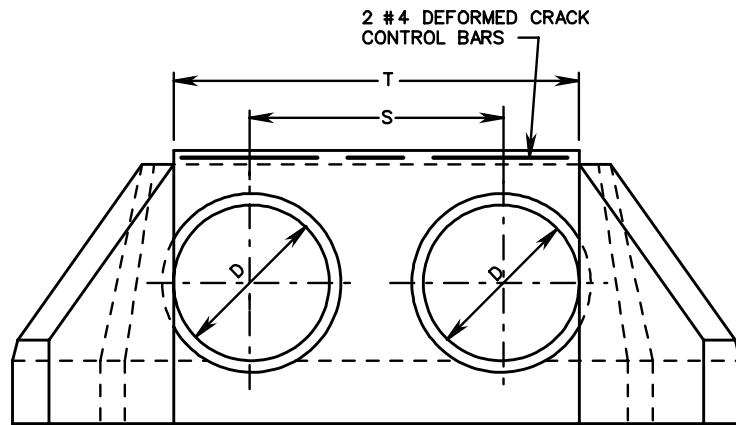

FRONT VIEW

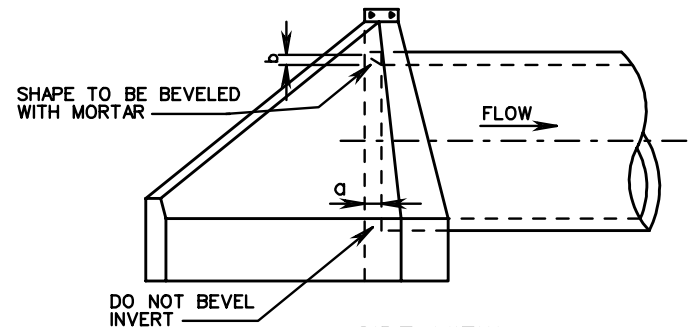

SIDE VIEW

FOR CONCRETE PIPE									
D	S	T	FILL SLOPE 1/2:1		FILL SLOPE 2:1		a	b	
			CONCRETE ONE DBL. ENDWALL CUBIC YARDS	INCREASE FOR EACH ADDITIONAL PIPE CUBIC YDS.	CONCRETE ONE DBL. ENDWALL CUBIC YARDS	INCREASE FOR EACH ADDITIONAL PIPE CUBIC YDS.			
42"	6'-0"	9'-6"	4.829	1.271	5.493	1.255	0'-4 1/2"	0'-3 1/2"	
48"	6'-10"	10'-10"	5.964	1.591	6.802	1.572	0'-5"	0'-4"	
54"	7'-8"	12'-2"	7.692	2.057	8.796	2.035	0'-5 3/4"	0'-4 1/2"	
60"	8'-6"	13'-6"	9.689	2.600	11.112	2.574	0'-6 1/4"	0'-5"	
66"	9'-4"	14'-10"	12.016	3.240	13.811	3.209	0'-7"	0'-5 1/2"	
72"	10'-2"	16'-2"	14.663	3.961	16.885	3.927	0'-7 1/2"	0'-6"	
78"	11'-0"	17'-6"	17.612	4.751	20.325	4.713	0'-8 1/4"	0'-6 1/2"	
84"	11'-10"	18'-10"	21.148	5.696	24.387	5.617	0'-8 3/4"	0'-7"	
90"	12'-8"	20'-2"	25.115	6.920	28.976	6.872	0'-9 1/2"	0'-7 1/2"	
96"	13'-6"	21'-6"	29.439	8.153	33.999	8.101	0'-10"	0'-8"	

FOR CORRUGATED METAL PIPE									
D	S	T	FILL SLOPE 1/2:1		FILL SLOPE 2:1		a	b	
			CONCRETE ONE DBL. ENDWALL CUBIC YARDS	INCREASE FOR EACH ADDITIONAL PIPE CUBIC YDS.	CONCRETE ONE DBL. ENDWALL CUBIC YARDS	INCREASE FOR EACH ADDITIONAL PIPE CUBIC YDS.			
42"	5'-3 1/2"	8'-9 1/2"	5.070	1.279	5.732	1.263	0'-4 1/2"	0'-3 1/2"	
48"	6'-0 1/2"	10'-0 1/2"	6.296	1.616	7.132	1.596	0'-5"	0'-4"	
54"	6'-9 1/2"	11'-3 1/2"	8.228	2.104	9.258	2.081	0'-5 3/4"	0'-4 1/2"	
60"	7'-6 1/2"	12'-6 1/2"	10.319	2.677	11.738	2.650	0'-6 1/4"	0'-5"	
66"	8'-3 1/2"	13'-9 1/2"	12.751	3.261	14.543	3.231	0'-7"	0'-5 1/2"	
72"	9'-0 1/2"	15'-0 1/2"	15.673	4.068	17.889	4.033	0'-7 1/2"	0'-6"	
78"	9'-9 1/2"	16'-3 1/2"	18.918	4.934	21.623	4.893	0'-8 1/4"	0'-6 1/2"	
84"	10'-6 1/2"	17'-6 1/2"	22.733	5.905	25.999	5.860	0'-8 3/4"	0'-7"	
90"	11'-3 1/2"	18'-9 1/2"	26.800	7.076	30.643	7.025	0'-9 1/2"	0'-7 1/2"	
96"	12'-0 1/2"	20'-0 1/2"	31.460	8.353	36.000	8.296	0'-10"	0'-8"	

SPECIFICATION REFERENCE
105 302

STANDARD ENDWALLS FOR MULTIPLE PIPE CULVERTS
42" - 96" CIRCULAR PIPES
 VIRGINIA DEPARTMENT OF TRANSPORTATION

VDOT ROAD AND BRIDGE STANDARDS	
REVISION DATE	SHEET 1 OF 1
101.17	

FOR CONCRETE OR CORRUGATED METAL PIPE

PIPE I.D.	H	T	S	1/2:1 SLOPE	2:1 SLOPE	a	b
42"	5'-6"	12'-6"	6'-0"	6'-7 1/2"	8'-8"	0'-4 1/2"	0'-3 1/2"
48"	6'-0"	13'-10"	6'-10"	7'-6"	9'-10"	0'-5"	0'-4"
54"	6'-6"	15'-2"	7'-8"	8'-4 1/2"	11'-0"	0'-5 3/4"	0'-4 1/2"
60"	7'-0"	16'-6"	8'-6"	9'-3"	12'-1 1/2"	0'-6 1/4"	0'-5"
66"	7'-7"	17'-10"	9'-4"	10'-1 1/2"	13'-3 1/2"	0'-7"	0'-5 1/2"
72"	8'-2"	19'-2"	10'-2"	11'-0"	14'-5 1/2"	0'-7"	0'-5 1/2"
78"	8'-8 1/2"	20'-6"	11'-0"	11'-10"	15'-7"	0'-7"	0'-5 1/2"
84"	9'-3"	21'-10"	11'-10"	12'-8 1/2"	16'-9"	0'-7"	0'-5 1/2"
90"	9'-11"	23'-5"	12'-9"	13'-7"	17'-11"	0'-7"	0'-5 1/2"
96"	10'-7"	25'-0"	13'-7"	14'-6"	19'-0 1/2"	0'-7"	0'-5 1/2"

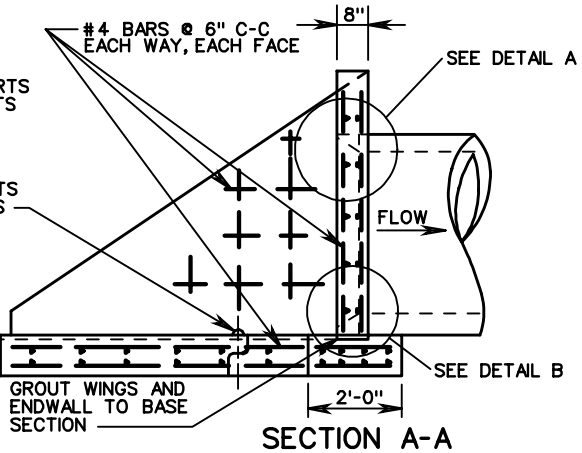
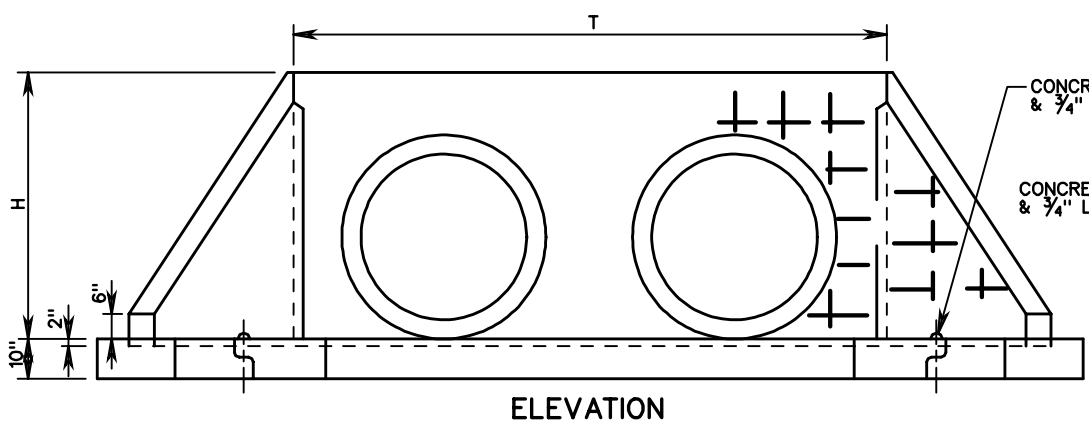
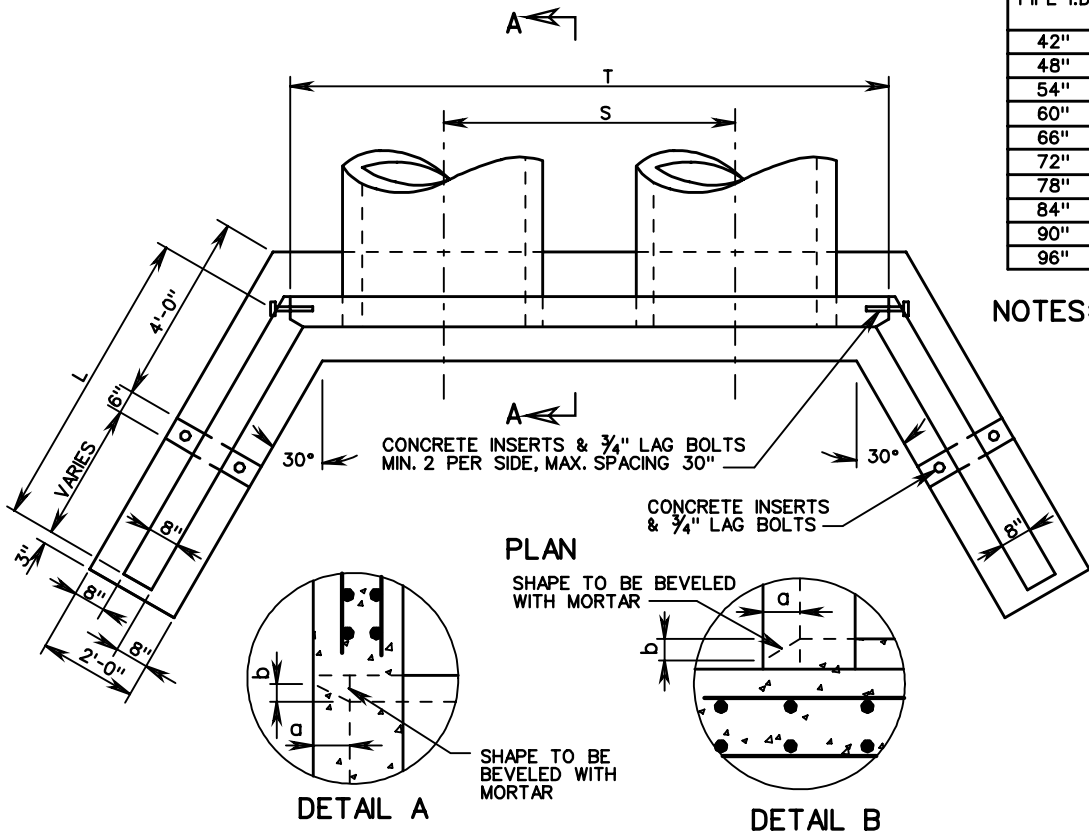

- NOTES:**
1. CONCRETE TO BE 4000 PSI MINIMUM COMPRESSIVE STRENGTH.
 2. IF PIPE IS TO BE SKEWED, THE OPENING WILL BE ADJUSTED TO ACCOMMODATE ANGLES UP TO 15°.
 3. REINFORCING STEEL IN ACCORDANCE WITH ASTM A-615 (REINFORCING BARS).
 4. PIPE OPENINGS IN PRECAST DRAINAGE UNITS SHALL NOT EXCEED 4 INCHES AT ANY GIVEN POINT BETWEEN THE PIPE AND THE PRECAST UNIT.
 5. DIMENSIONS SHOWN ARE MINIMUM. ACTUAL MEASUREMENTS MAY VARY WITH MANUFACTURER'S TOLERANCES.
 6. IN NO CASE SHALL TOP OF ENDWALL PROTRUDE ABOVE FILL SLOPE, DITCH SLOPE, OR SHOULDER.
 7. HEADWALL TO BE BEVELED IN ALL AREAS EXCEPT WHERE A CONFLICT WITH INVERT OR WINGWALL OCCUR.
 8. BEVEL EDGE AS REQUIRED ON THE HEADWALL AT THE INLET END OF THE CULVERT (WHERE THE FLOW ENTERS THE CULVERT).
 9. HEADWALL AT THE OUTLET END OF THE CULVERT MAY BE EITHER SQUARE EDGE OR BEVEL EDGE.
 10. 3/4" CHAMFER MAY BE PROVIDED ON ALL EDGES AT MANUFACTURER'S OPTION.

NOTES:

1. QUANTITIES GIVEN ARE FOR ONE ENDWALL.
2. PLEASE REFER TO STANDARD EW-2S, SHEETS 101.08 AND 101.09, FOR ALL DIMENSIONS NOT GIVEN IN TABLES.
3. THIS ITEM MAY BE PRECAST OR CAST IN PLACE.
4. ON SHALLOW FILLS, WHERE ENDWALLS ARE 1' OR LESS BELOW SHOULDER LINE, THE TOP OF THE ENDWALL SHALL BE CONSTRUCTED PARALLEL TO THE GRADE OF ROAD.
5. ALL CAST IN PLACE CONCRETE TO BE CLASS A3. FOR PRECAST SEE SHEET 101.21.
6. IN NO CASE SHALL TOP OF ENDWALL PROJECT ABOVE FILL SLOPE, DITCH SLOPE, OR SHOULDER.
7. THIS STANDARD TO BE USED WITH SKEW ANGLES FROM 15° TO 37° 30'.
8. COST OF BARS FOR CRACK CONTROL TO BE INCLUDED IN PRICE PER BID PER CUBIC YARD CONCRETE.
9. HEADWALL TO BE BEVELED IN ALL AREAS EXCEPT WHERE A CONFLICT WITH INVERT AND WINGWALLS OCCUR.
10. BEVEL EDGE IS REQUIRED ON THE HEADWALL AT THE INLET END OF THE CULVERT (WHERE THE FLOW ENTERS THE CULVERT). HEADWALL AT THE OUTLET END OF THE CULVERT MAY BE EITHER SQUARE EDGE OR BEVEL EDGE.
11. 3/4" CHAMFER MAY BE PROVIDED ON ALL EDGES AT MANUFACTURER'S OPTION.

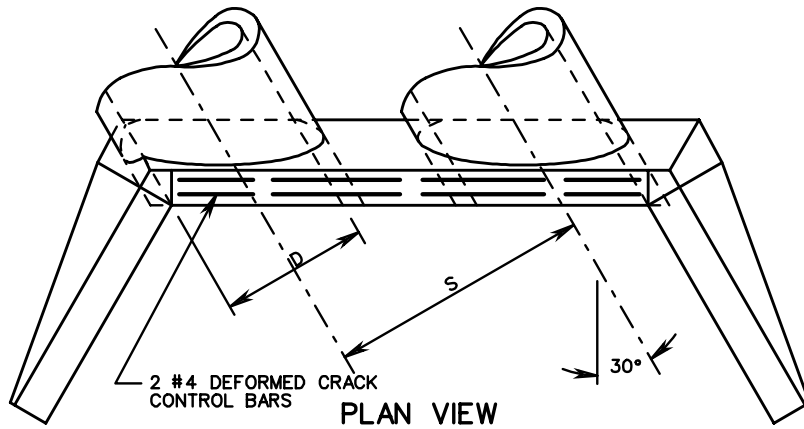

PLAN VIEW

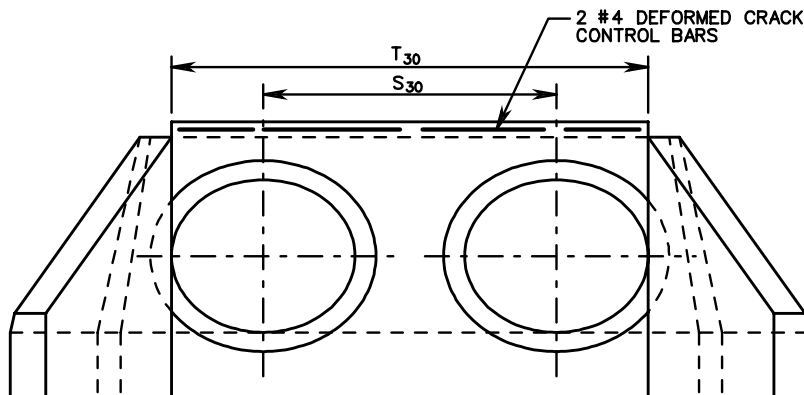

FRONT VIEW

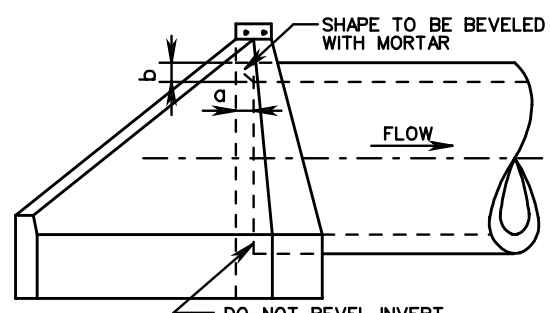

SIDE VIEW

FOR CONCRETE PIPE OR CORRUGATED METAL PIPE		
PIPE I.D.	a	b
42"	0'-4 1/2"	0'-3 1/2"
48"	0'-5"	0'-4"
54"	0'-5 3/4"	0'-4 1/2"
60"	0'-6 1/4"	0'-5"
66"	0'-7"	0'-5 1/2"
72"	0'-7 1/2"	0'-6"
78"	0'-8 1/4"	0'-6 1/2"
84"	0'-8 3/4"	0'-7"
90"	0'-9 1/2"	0'-7 1/2"
96"	0'-10"	0'-8"

FOR CONCRETE PIPE							
D	S	S ₃₀	T ₃₀	FILL SLOPE 1/2:1		FILL SLOPE 2:1	
				CONCRETE IN ONE DOUBLE ENDWALL CUBIC YARDS	INCREASE FOR EACH ADDITIONAL PIPE CUBIC YDS.	CONCRETE IN ONE DOUBLE ENDWALL CUBIC YDS.	INCREASE FOR EACH ADDITIONAL PIPE CUBIC YDS.
42"	6'-0"	6'-11 1/8"	10'-11 5/8"	5.098	1.467	5.759	1.449
48"	6'-10"	7'-10 5/8"	12'-6 1/4"	6.295	1.836	7.129	1.814
54"	7'-8"	8'-10 1/4"	14'-0 5/8"	8.121	2.376	9.218	2.350
60"	8'-6"	9'-9 3/4"	15'-7"	10.224	3.001	11.640	2.971
66"	9'-4"	10'-9 3/8"	17'-1 1/2"	12.663	3.729	14.450	3.693
72"	10'-2"	11'-8 7/8"	18'-8"	15.437	4.552	17.650	4.512
78"	11'-0"	12'-8 3/8"	20'-2 1/2"	18.558	5.482	21.261	5.438
84"	11'-10"	13'-8"	21'-9"	22.081	6.537	25.351	6.488
90"	12'-8"	14'-7 1/2"	23'-3 1/2"	26.445	8.207	30.302	7.934
96"	13'-6"	15'-7"	24'-10"	30.998	9.654	35.556	9.348

FOR CORRUGATED METAL PIPE							
D	S	S ₃₀	T ₃₀	FILL SLOPE 1/2:1		FILL SLOPE 2:1	
				CONCRETE IN ONE DOUBLE ENDWALL CUBIC YDS.	INCREASE FOR EACH ADDITIONAL PIPE CUBIC YDS.	CONCRETE IN ONE DOUBLE ENDWALL CUBIC YDS.	INCREASE FOR EACH ADDITIONAL PIPE CUBIC YDS.
42"	5'-3 1/2"	6'-1 3/8"	10'-1 7/8"	5.364	1.464	6.021	1.445
48"	6'-0 1/2"	6'-11 3/4"	11'-7 1/8"	6.663	1.849	7.494	1.827
54"	6'-9 1/2"	7'-10 3/8"	13'-0 1/2"	8.737	2.409	9.731	2.382
60"	7'-6 1/2"	8'-8 1/2"	14'-5 3/8"	10.927	3.066	12.339	3.035
66"	8'-3 1/2"	9'-6 3/8"	15'-11 1/8"	13.585	3.827	15.354	3.777
72"	9'-0 1/2"	10'-5 1/4"	17'-4 3/8"	16.666	4.738	18.834	4.659
78"	9'-9 1/2"	11'-3 3/8"	18'-9 3/4"	20.066	5.693	22.761	5.647
84"	10'-6 1/2"	12'-2 1/8"	20'-3 3/8"	23.954	6.822	27.214	6.770
90"	11'-3 1/2"	13'-0 1/2"	21'-8 1/2"	28.395	8.174	32.232	8.115
96"	12'-0 1/2"	13'-10 1/8"	23'-1 3/4"	33.328	9.647	37.863	9.582

SPECIFICATION REFERENCE
105
302

STANDARD ENDWALL FOR MULTIPLE PIPE CULVERTS
42" - 96" CIRCULAR PIPES WITH 30° SKEW
VIRGINIA DEPARTMENT OF TRANSPORTATION

VDOT
ROAD AND BRIDGE STANDARDS
REVISION DATE SHEET 1 OF 1
101.19

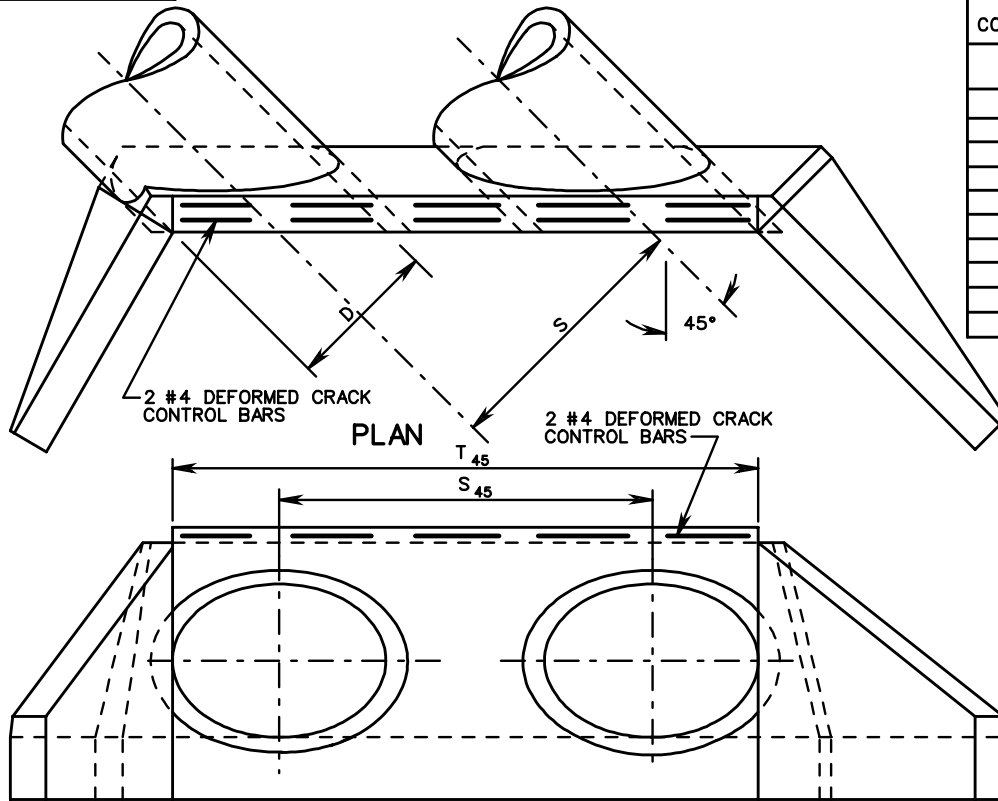

FRONT VIEW

FOR CONCRETE PIPE OR CORRUGATED METAL PIPE		
PIPE I.D.	a	b
42"	0'-4 ¹ / ₂ "	0'-3 ¹ / ₂ "
48"	0'-5"	0'-4"
54"	0'-5 ³ / ₄ "	0'-4 ¹ / ₂ "
60"	0'-6 ¹ / ₄ "	0'-5"
66"	0'-7"	0'-5 ¹ / ₂ "
72"	0'-7 ¹ / ₂ "	0'-6"
78"	0'-8 ¹ / ₄ "	0'-6 ¹ / ₂ "
84"	0'-8 ³ / ₄ "	0'-7"
90"	0'-9 ¹ / ₂ "	0'-7 ¹ / ₂ "
96"	0'-10"	0'-8"

NOTES:

1. QUANTITIES GIVEN ARE FOR ONE ENDWALL.
2. PLEASE REFER TO STANDARD EW-2S, SHEET 101.08 AND 101.09, FOR ALL DIMENSIONS NOT GIVEN IN TABLES.
3. THIS ITEM MAY BE PRECAST OR CAST IN PLACE.
4. ON SHALLOW FILLS, WHERE ENDWALLS ARE 1' OR LESS BELOW SHOULDER LINE, THE TOP OF THE ENDWALL SHALL BE CONSTRUCTED PARALLEL TO THE GRADE OF ROAD.
5. ALL CAST IN PLACE CONCRETE TO BE CLASS A3. FOR PRECAST SEE SHEET 101.21.
6. IN NO CASE SHALL TOP OF ENDWALL PROJECT ABOVE FILL SLOPE, DITCH SLOPE, OR SHOULDER.
7. THIS STANDARD TO BE USED WITH SKEW ANGLES FROM 37° 30' TO 45°.
8. COST OF BARS FOR CRACK CONTROL TO BE INCLUDED IN PRICE BID PER CUBIC YARD CONCRETE.
9. HEADWALL TO BE BEVELED IN ALL AREAS EXCEPT WHERE A CONFLICT WITH INVERT AND WINGWALLS OCCUR.
10. BEVEL EDGE IS REQUIRED ON THE HEADWALL AT THE INLET END OF THE CULVERT (WHERE THE FLOW ENTERS THE CULVERT). HEADWALL AT THE OUTLET END OF THE CULVERT MAY BE EITHER SQUARE EDGE OR BEVEL EDGE.
11. FOR DETAILS OF HEADWALL BEVEL SEE STANDARD EW-2S, SHEETS 101.08 AND 101.09.
12. 3/4" CHAMFER MAY BE PROVIDED ON ALL EDGES AT MANUFACTURER'S OPTION.

FOR CONCRETE PIPE							
D	S	S ₄₅	T ₄₅	FILL SLOPE 1/2:1		FILL SLOPE 2:1	
				CONCRETE IN ONE DOUBLE ENDWALL CUBIC YARDS	INCREASE FOR EACH ADDITIONAL PIPE CUBIC YARDS	CONCRETE IN ONE DOUBLE ENDWALL CUBIC YDS.	INCREASE FOR EACH ADDITIONAL PIPE CUBIC YDS.
42"	6'-0"	8'-5 ¹ / ₈ "	13'-5 ¹ / ₄ "	6.030	1.799	6.819	1.776
48"	6'-10"	9'-8"	15'-3 ¹ / ₈ "	7.443	2.252	8.479	2.225
54"	7'-8"	10'-10 ¹ / ₈ "	17'-2 ¹ / ₂ "	9.621	2.909	10.949	2.878
60"	8'-6"	12'-0 ¹ / ₄ "	19'-1 ¹ / ₈ "	12.124	3.677	13.935	3.640
66"	9'-4"	13'-2 ³ / ₈ "	20'-11 ¹ / ₄ "	15.003	4.562	17.148	4.520
72"	10'-2"	14'-4 ¹ / ₂ "	22'-10 ³ / ₈ "	18.287	5.573	20.953	5.524
78"	11'-0"	15'-6 ⁵ / ₈ "	24'-9"	21.991	6.715	25.247	6.662
84"	11'-10"	16'-8 ¹ / ₈ "	26'-7 ⁵ / ₈ "	26.158	8.008	30.089	7.947
90"	12'-8"	17'-11"	28'-6 ¹ / ₄ "	31.209	9.789	35.937	9.779
96"	13'-6"	19'-1 ¹ / ₈ "	30'-4 ¹ / ₈ "	36.640	11.533	42.212	11.523

FOR CORRUGATED METAL PIPE							
D	S	S ₄₅	T ₄₅	FILL SLOPE 1/2:1		FILL SLOPE 2:1	
				CONCRETE IN ONE DOUBLE ENDWALL CUBIC YDS.	INCREASE FOR EACH ADDITIONAL PIPE CUBIC YDS.	CONCRETE IN ONE DOUBLE ENDWALL CUBIC YDS.	INCREASE FOR EACH ADDITIONAL PIPE CUBIC YDS.
42"	5'-3 ¹ / ₂ "	7'-5 ³ / ₄ "	12'-5 ¹ / ₄ "	6.331	1.789	7.118	1.767
48"	6'-0 ¹ / ₂ "	8'-6 ¹ / ₈ "	14'-2 ³ / ₄ "	7.866	2.262	8.900	2.236
54"	6'-9 ¹ / ₂ "	9'-7 ¹ / ₄ "	15'-11 ⁵ / ₈ "	10.223	2.949	11.526	2.917
60"	7'-6 ¹ / ₂ "	10'-8"	17'-8 ¹ / ₈ "	12.944	3.755	14.750	3.717
66"	8'-3 ¹ / ₂ "	11'-8 ³ / ₄ "	19'-6"	16.090	4.690	18.236	4.646
72"	9'-0 ¹ / ₂ "	12'-9 ¹ / ₂ "	21'-3 ¹ / ₄ "	19.690	5.763	22.347	5.712
78"	9'-9 ¹ / ₂ "	13'-10 ¹ / ₈ "	23'-0 ¹ / ₂ "	23.757	6.974	27.003	6.917
84"	10'-6 ¹ / ₂ "	14'-10 ¹ / ₈ "	24'-9 ¹ / ₄ "	28.347	8.350	32.265	8.284
90"	11'-3 ¹ / ₂ "	15'-11 ⁵ / ₈ "	26'-7"	33.600	10.007	38.292	9.983
96"	12'-0 ¹ / ₂ "	17'-0 ³ / ₈ "	28'-4 ¹ / ₈ "	39.499	11.815	45.031	11.790



ROAD AND BRIDGE STANDARDS

SHEET 1 OF 1

REVISION DATE

101.20

STANDARD ENDWALLS FOR MULTIPLE PIPE CULVERTS

42" - 96" CIRCULAR PIPE WITH 45° SKEW

VIRGINIA DEPARTMENT OF TRANSPORTATION

SPECIFICATION REFERENCE

105
302

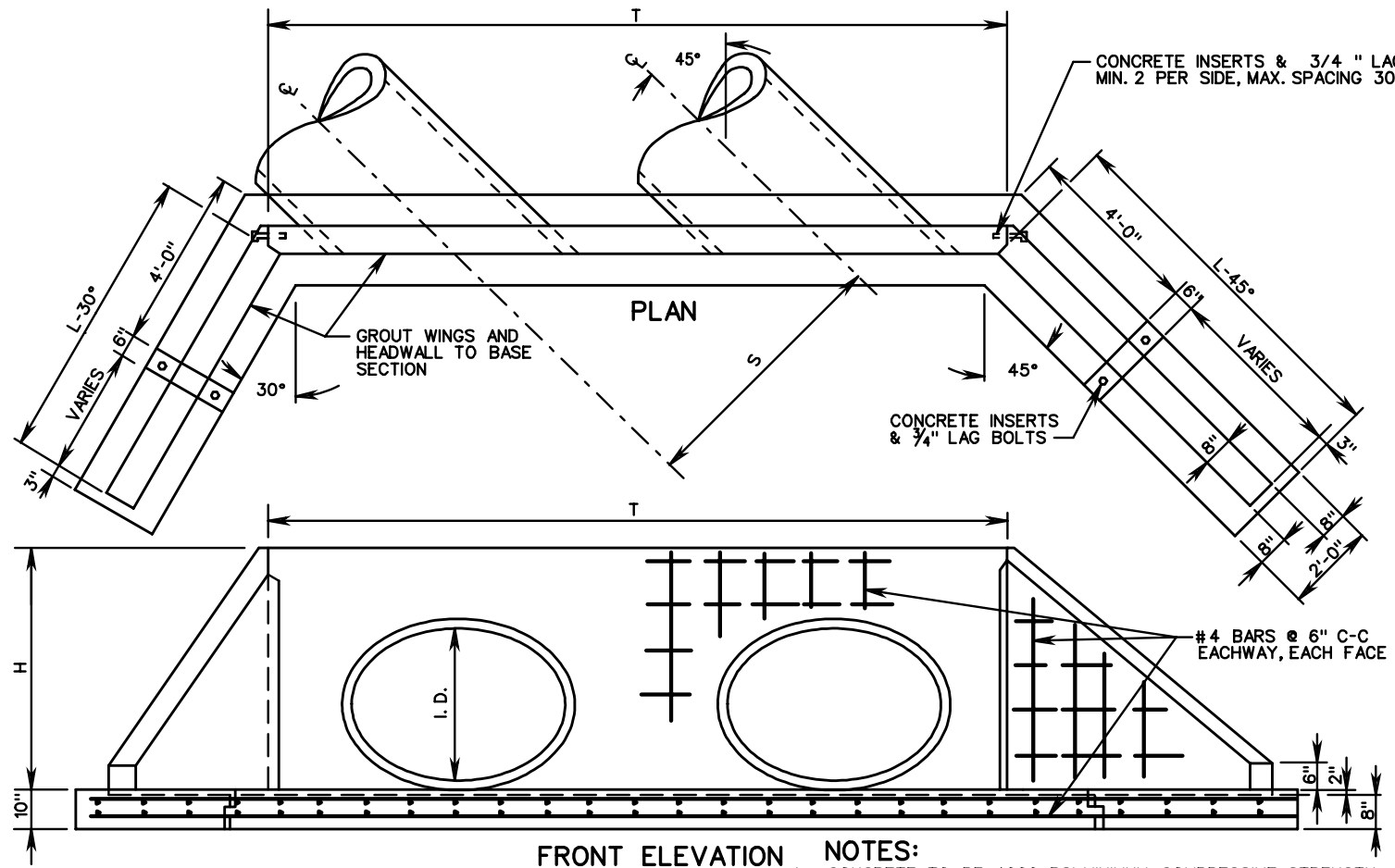

- NOTES:**
1. CONCRETE TO BE 4000 PSI MINIMUM COMPRESSIVE STRENGTH.
 2. FOR DETAILS OF HEADWALL BEVEL SEE STANDARD EW-2SPC, SHEET 101.10.
 3. REINFORCING STEEL IN ACCORDANCE WITH ASTM A-615 (REINFORCING BARS).
 4. PIPE OPENINGS IN PRECAST DRAINAGE UNITS SHALL NOT EXCEED 4 INCHES AT ANY GIVEN POINT BETWEEN THE PIPE AND THE PRECAST UNIT.
 5. DIMENSIONS SHOWN ARE MINIMUM. ACTUAL MEASUREMENTS MAY VARY WITH MANUFACTURER'S TOLERANCES.
 6. IN NO CASE SHALL TOP OF ENDWALL PROTRUDE ABOVE FILL SLOPE, DITCH SLOPE, OR SHOULDER.
 7. HEADWALL TO BE BEVELED IN ALL AREAS EXCEPT WHERE A CONFLICT WITH INVERT OR WINGWALL OCCUR.
 8. BEVEL EDGE AS REQUIRED ON THE HEADWALL AT THE INLET END OF THE CULVERT (WHERE THE FLOW ENTERS THE CULVERT).
 9. HEADWALL AT THE OUTLET END OF THE CULVERT MAY BE EITHER SQUARE EDGE OR BEVEL EDGE.
 10. 3/4" CHAMFER MAY BE PROVIDED ON ALL EDGES AT MANUFACTURER'S OPTION.

FOR CIRCULAR CONCRETE OR CORRUGATED METAL PIPE

DIMENSIONS									
PIPE I.D.	H	T	S	L-30° 1/2:1 SLOPE	L-30° 2:1 SLOPE	L-45° 1/2:1 SLOPE	L-45° 2:1 SLOPE	a	b
42"	5'-6"	16'-6"	6'-0"	6'-7 1/2"	8'-8"	8'-0"	10'-6"	0'-4 1/2"	0'-3 1/2"
48"	6'-0"	18'-4"	6'-10"	7'-6"	9'-9 3/4"	9'-2 1/2"	12'-0"	0'-5"	0'-4"
54"	6'-6"	20'-3"	7'-8"	8'-4 1/2"	10'-11 1/2"	10'-3"	13'-6"	0'-5 3/4"	0'-4 1/2"
60"	7'-0"	22'-2"	8'-6"	9'-3"	12'-1 1/4"	11'-3 1/2"	14'-10 1/4"	0'-6 1/4"	0'-5"
66"	7'-7"	24'-0"	9'-4"	10'-1 1/4"	13'-3 1/2"	12'-4 1/2"	16'-4"	0'-7"	0'-5 1/2"
72"	8'-2"	25'-11"	10'-2"	11'-0"	14'-5 1/2"	13'-5 1/2"	17'-8"	0'-7"	0'-5 1/2"
78"	8'-8 1/2"	27'-10"	11'-0"	11'-10"	15'-7"	14'-6"	19'-0"	0'-7"	0'-5 1/2"
84"	9'-3"	29'-8"	11'-10"	12'-8 1/2"	16'-9"	15'-6"	20'-6"	0'-7"	0'-5 1/2"
90"	9'-11"	31'-8"	12'-8"	13'-7"	17'-11"	16'-7 1/2"	21'-11"	0'-7"	0'-5 1/2"
96"	10'-7"	33'-8"	13'-6"	14'-5 1/4"	19'-1"	17'-8 1/4"	23'-4"	0'-7"	0'-5 1/2"

SPECIFICATION REFERENCE
105
302

PRECAST ENDWALLS FOR MULTIPLE PIPE CULVERTS

42" - 96" CIRCULAR PIPES WITH 45° SKEW

VIRGINIA DEPARTMENT OF TRANSPORTATION



ROAD AND BRIDGE STANDARDS

REVISION DATE SHEET 1 OF 1

101.21

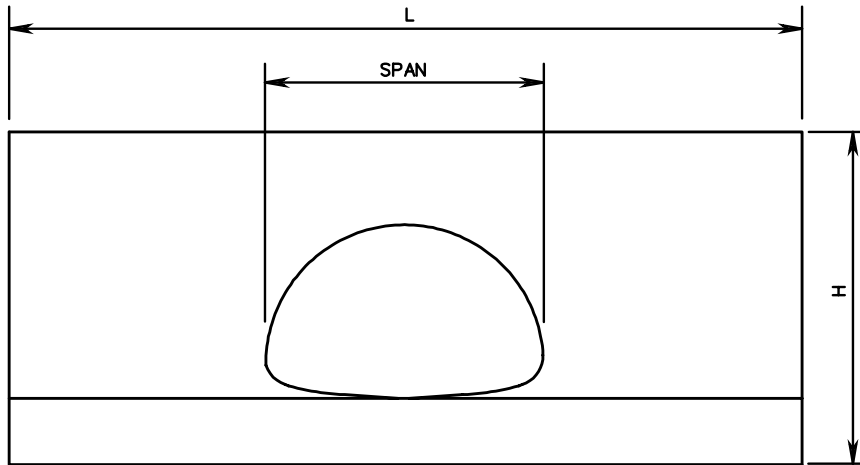

FRONT ELEVATION

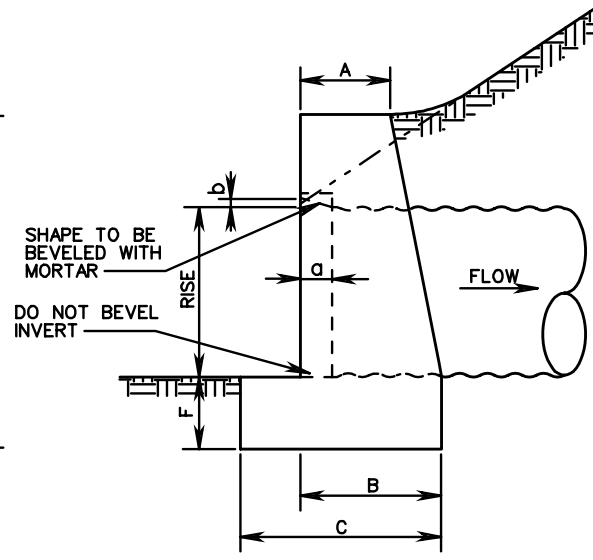

SIDE ELEVATION

NOTES:

1. THIS ITEM MAY BE PRECAST OR CAST IN PLACE.
2. ON SHALLOW FILLS, WHERE ENDWALLS ARE 1' OR LESS BELOW SHOULDER LINE, THE TOP OF THE ENDWALL SHALL BE CONSTRUCTED PARALLEL TO THE GRADE OF ROAD.
3. ALL CAST IN PLACE CONCRETE TO BE CLASS A3. FOR PRECAST SEE SHEET 101.23.
4. IN NO CASE SHALL TOP OF ENDWALL PROJECT ABOVE FILL SLOPE, DITCH SLOPE, OR SHOULDER.
5. HEADWALL TO BE BEVELED IN ALL AREAS EXCEPT WHERE A CONFLICT WITH INVERT AND WINGWALLS OCCUR.
6. BEVEL EDGE IS REQUIRED ON THE HEADWALL AT THE INLET END OF THE CULVERT (WHERE THE FLOW ENTERS THE CULVERT). HEADWALL AT THE OUTLET END OF THE CULVERT MAY BE EITHER SQUARE EDGE OR BEVEL EDGE.
7. 3/4" CHAMFER MAY BE PROVIDED ON ALL EDGES AT MANUFACTURER'S OPTION.

CORRUGATED METAL PIPE										
NOMINAL DIMENSIONS OF PIPE ARCH		DIMENSIONS FOR ONE SINGLE ENDWALL						CUBIC YARDS CONCRETE FOR ONE ENDWALL	a	b
SPAN	RISE	A	B	C	F	H	L			
17"	13"	0'-6"	0'-11"	1'-4"	0'-6"	2'-2"	4'-3"	0.258	0'-2"	0'-1/4"
21"	15"	0'-6"	0'-11"	1'-4"	0'-6"	2'-4"	5'-1"	0.322	0'-2 1/2"	0'-1 1/2"
24"	18"	0'-8"	1'-1 1/2"	1'-7"	0'-8"	3'-0"	6'-1"	0.626	0'-3"	0'-2"
28"	20"	0'-9"	1'-3"	1'-9"	0'-8"	3'-2"	6'-11"	0.823	0'-3"	0'-2"
35"	24"	0'-11"	1'-6"	2'-2"	0'-9"	3'-7"	8'-6"	1.371	0'-4"	0'-2 1/2"
42"	29"	1'-0"	1'-9"	2'-6"	0'-9"	4'-0"	10'-4"	2.072	0'-4 1/2"	0'-3"
*40"	31"	1'-0"	1'-9"	2'-6"	0'-9"	4'-4"	11'-11"	2.520	0'-5 1/2"	0'-3 1/2"
49"	33"									
*46"	36"	1'-0"	2'-0"	2'-9"	0'-9"	4'-9"	13'-10"	3.427	0'-6"	0'-4"
57"	38"									
*53"	41"									

*3" x 1" AND 5" x 1" CORRUGATION DIMENSIONS.



ROAD AND BRIDGE STANDARDS

STANDARD ENDWALLS FOR PIPE ARCHES

SPECIFICATION REFERENCE

SHEET 1 OF 1

REVISION DATE

13" - 38" RISE

VIRGINIA DEPARTMENT OF TRANSPORTATION

101.22

105
302

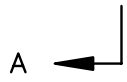
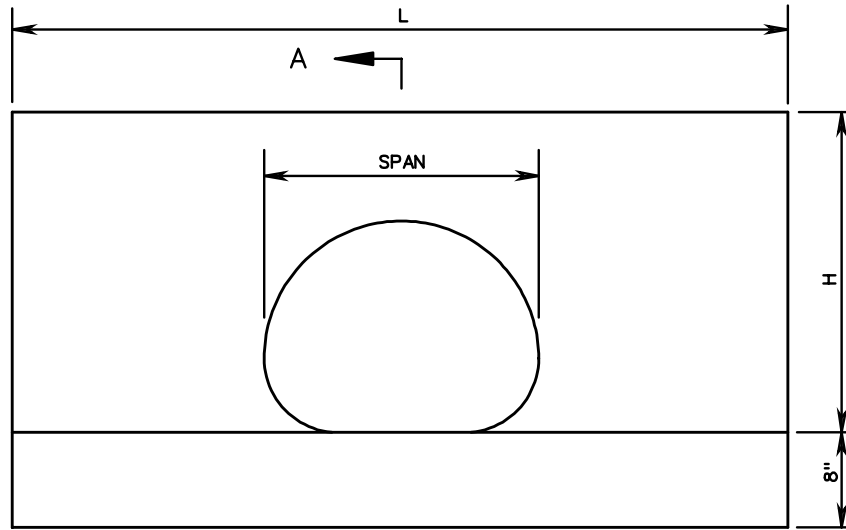

FRONT ELEVATION

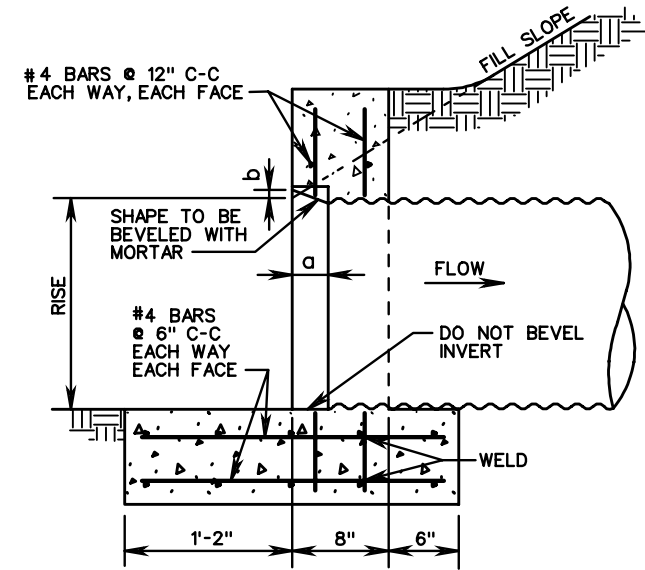

SECTION A-A

NOTES:

1. CONCRETE TO BE 4000 PSI MINIMUM COMPRESSIVE STRENGTH.
2. IF PIPE IS TO BE SKEWED THE OPENING WILL BE ADJUSTED TO ACCOMMODATE.
3. REINFORCING STEEL IN ACCORDANCE WITH ASTM A-615 (REINFORCING BARS).
4. PIPE ARCH OPENINGS IN PRECAST DRAINAGE UNITS SHALL NOT EXCEED 4 INCHES AT ANY GIVEN POINT BETWEEN THE PIPE AND THE PRECAST UNIT.
5. DIMENSIONS SHOWN ARE MINIMUM. ACTUAL MEASUREMENTS MAY VARY WITH MANUFACTURER'S TOLERANCE.
6. IN NO CASE SHALL TOP OF ENDWALL PROJECT ABOVE FILL SLOPE, OR SHOULDER.
7. HEADWALL TO BE BEVELED IN ALL AREAS EXCEPT WHERE A CONFLICT WITH INVERT OR WINGWALL OCCUR.
8. BEVEL EDGE IS REQUIRED ON THE HEADWALL AT THE INLET END OF THE CULVERT HEADWALL AT OUTLET END MAY BE EITHER SQUARE EDGE OR BEVELED.
9. 3/4" CHAMFER MAY BE PROVIDED ON ALL EDGES AT MANUFACTURER'S OPTION.

PRECAST ENDWALL DIMENSIONS					
SPAN	RISE	H	L	a	b
17"	13"	1'-8"	4'-0"	0'-2"	0'-1/4"
21"	15"	1'-10"	5'-0"	0'-2 1/2"	0'-1 1/2"
24"	18"	2'-4"	6'-0"	0'-3"	0'-2"
28"	20"	2'-6"	7'-0"	0'-3"	0'-2"
35"	24"	2'-10"	8'-0"	0'-4"	0'-2 1/2"
* 40"	31"	3'-3"	10'-0"	0'-4 1/2"	0'-3"
42"	29"				
* 46"	36"	3'-7"	12'-0"	0'-5 1/2"	0'-3 1/2"
49"	33"				
* 53"	41"	4'-0"	13'-0"	0'-6"	0'-4"
57"	38"				

* DIMENSIONS FOR 3" x 1" AND 5" x 1" CORRUGATIONS

SPECIFICATION REFERENCE
105 302

PRECAST ENDWALLS FOR PIPE ARCHES
 13" - 38" RISE
 VIRGINIA DEPARTMENT OF TRANSPORTATION

VDOT ROAD AND BRIDGE STANDARDS	
REVISION DATE	SHEET 1 OF 1
101.23	

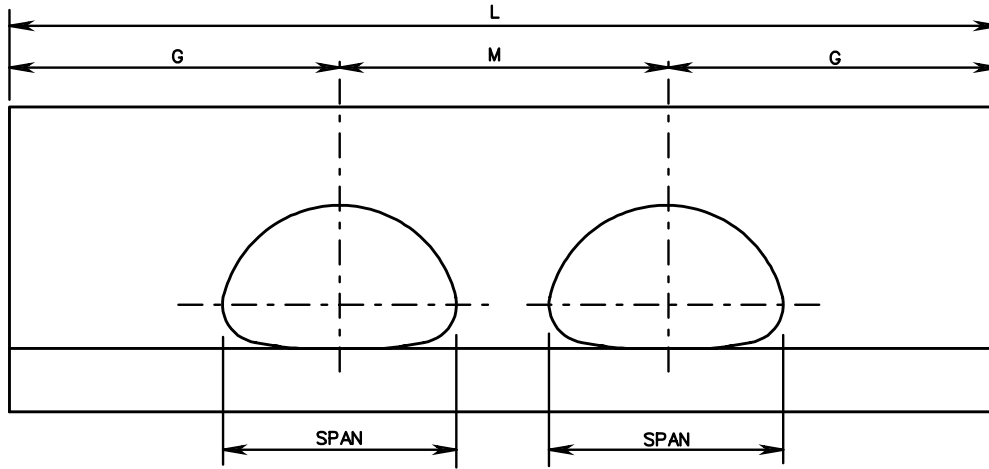

FRONT ELEVATION

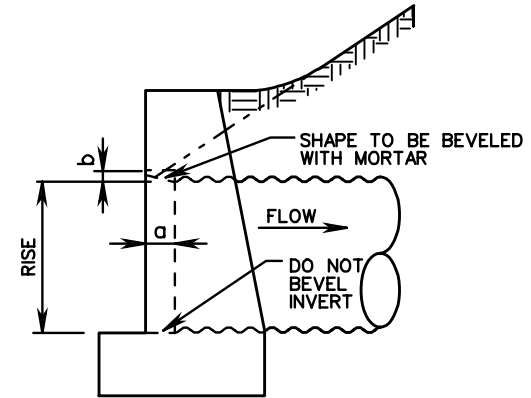

SIDE ELEVATION

NOTES:

1. THIS ITEM MAY BE PRECAST OR CAST IN PLACE.
2. REFER TO STANDARD EW-9, SHEET 101.22, FOR ALL DIMENSIONS NOT GIVEN IN TABLE.
3. ON SHALLOW FILLS, WHERE ENDWALLS ARE 1' OR LESS BELOW SHOULDER LINE, THE TOP OF THE ENDWALL SHALL BE CONSTRUCTED PARALLEL TO THE GRADE OF ROAD.
4. ALL CAST IN PLACE CONCRETE TO BE CLASS A3. FOR PRECAST SEE SHEET 101.25.
5. IN NO CASE SHALL TOP OF ENDWALL PROJECT ABOVE FILL SLOPE, DITCH SLOPE, OR SHOULDER.
6. HEADWALL TO BE BEVELED IN ALL AREAS EXCEPT WHERE A CONFLICT WITH INVERT AND WINGWALLS OCCUR.
7. BEVEL EDGE IS REQUIRED ON THE HEADWALL AT THE INLET END OF THE CULVERT (WHERE THE FLOW ENTERS THE CULVERT). HEADWALL AT THE OUTLET END OF THE CULVERT MAY BE EITHER SQUARE EDGE OR BEVEL EDGE.
8. 3/4" CHAMFER MAY BE PROVIDED ON ALL EDGES AT MANUFACTURER'S OPTION.

CORRUGATED METAL PIPE

NOMINAL DIMENSIONS OF PIPE ARCH		DIMENSIONS FOR ONE DOUBLE ENDWALL			CUBIC YARDS CONCRETE		a	b
SPAN	RISE	M	G	L	ONE DOUBLE ENDWALL	INCREASE FOR EACH ADDITIONAL PIPE ARCH		
17"	13"	2'-6"	2'-2"	6'-10"	0.402	0.138	0'-2"	0'-1 1/4"
21"	15"	2'-10"	2'-7"	8'-0"	0.487	0.159	0'-2 1/2"	0'-1 1/2"
24"	18"	3'-1"	3'-1"	9'-3"	0.913	0.277	0'-3"	0'-2"
28"	20"	3'-5"	3'-6"	10'-5"	1.182	0.348	0'-3"	0'-2"
35"	24"	4'-0"	4'-3"	12'-6"	1.900	0.529	0'-4"	0'-2 1/2"
42"	29"	4'-10"	5'-2"	15'-2"	2.852	0.780	0'-4 1/2"	0'-3"
* 40"	31"							
49"	33"	5'-7"	6'-0"	17'-7"	3.455	0.924	0'-5 1/2"	0'-3 1/2"
* 46"	36"							
57"	38"							
* 53"	41"	6'-6"	6'-11"	20'-4"	4.664	1.237	0'-6"	0'-4"

* 3" X 1" AND 5" X 1" CORRUGATION DIMENSIONS.



ROAD AND BRIDGE STANDARDS

STANDARD ENDWALLS FOR MULTIPLE PIPE ARCHES

13" - 38" RISE

VIRGINIA DEPARTMENT OF TRANSPORTATION

SPECIFICATION REFERENCE

SHEET 1 OF 1

REVISION DATE

101.24

105
302

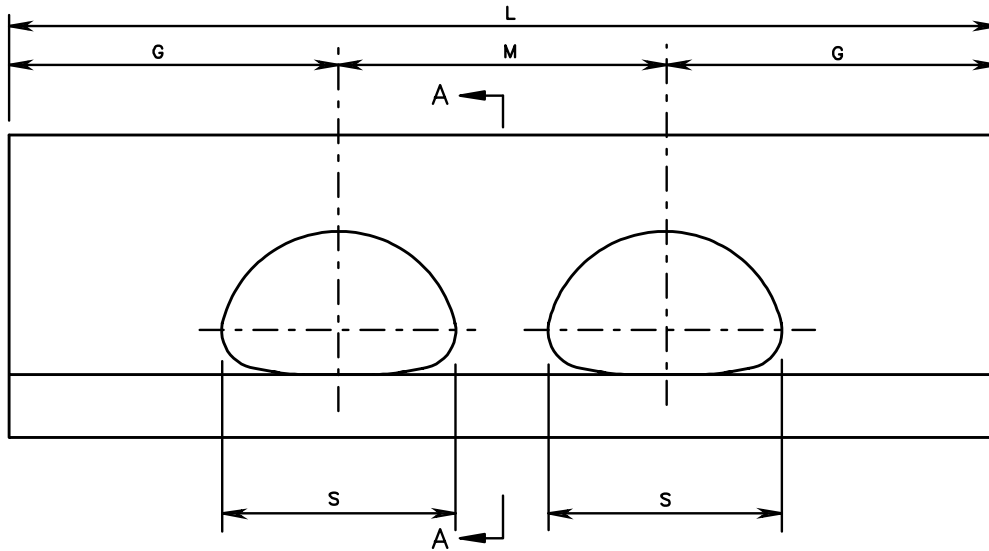

FRONT ELEVATION

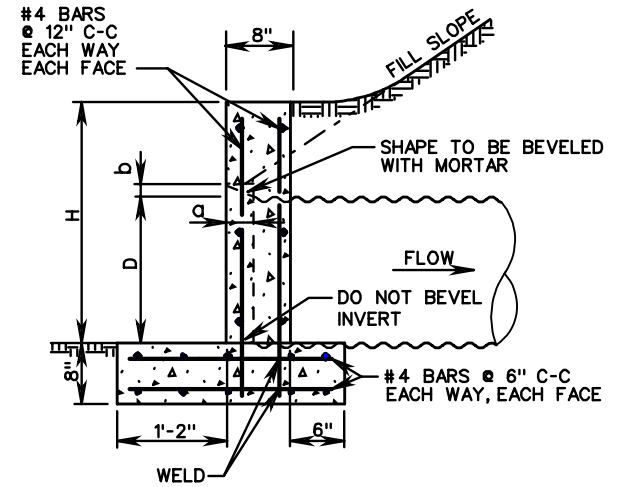

SECTION A-A

NOTES:

1. CONCRETE TO BE 4000 PSI MINIMUM COMPRESSIVE STRENGTH.
2. IF PIPE IS TO BE SKEWED THE OPENING WILL BE ADJUSTED TO ACCOMMODATE.
3. REINFORCING STEEL IN ACCORDANCE WITH ASTM A-615 (REINFORCING BARS).
4. PIPE ARCH OPENINGS IN PRECAST DRAINAGE UNITS SHALL NOT EXCEED 4 INCHES AT ANY GIVEN POINT BETWEEN THE PIPE AND THE PRECAST UNIT.
5. DIMENSIONS SHOWN ARE MINIMUM. ACTUAL MEASUREMENTS MAY VARY WITH MANUFACTURER'S TOLERANCE.
6. IN NO CASE SHALL TOP OF ENDWALL PROJECT ABOVE FILL SLOPE, OR SHOULDER.
7. HEADWALL TO BE BEVELED IN ALL AREAS EXCEPT WHERE A CONFLICT WITH INVERT OR WINGWALL OCCUR.
8. BEVEL EDGE IS REQUIRED ON THE HEADWALL AT THE INLET END OF THE CULVERT HEADWALL AT OUTLET END MAY BE EITHER SQUARE EDGE OR BEVELED.
9. 3/4" CHAMFER MAY BE PROVIDED ON ALL EDGES AT MANUFACTURER'S OPTION.

PRECAST ENDWALL DIMENSIONS

S	D	M	G	L	H	a	b
17"	13"	2'-6"	2'-2"	6'-10"	2'-3"	0'-2"	0'-1/4"
21"	15"	2'-10"	2'-7"	8'-0"	2'-5"	0'-2 1/2"	0'-1 1/2"
24"	18"	3'-1"	3'-1"	9'-3"	2'-8"	0'-3"	0'-2"
28"	20"	3'-5"	3'-6"	10'-5"	2'-10"	0'-3"	0'-2"
35"	24"	4'-0"	4'-3"	12'-6"	3'-2"	0'-4"	0'-2 1/2"
* 40"	31"	4'-10"	5'-2"	15'-2"	3'-7"	0'-4 1/2"	0'-3"
42"	29"						
* 46"	36"	5'-7"	6'-0"	17'-7"	3'-11"	0'-5 1/2"	0'-3 1/2"
49"	33"						
* 53"	41"	6'-6"	6'-11"	20'-4"	4'-4"	0'-6"	0'-4"
57"	38"						

* DIMENSIONS FOR 3" X 1" AND 5" X 1" CORRUGATION

SPECIFICATION REFERENCE

105
302

PRECAST ENDWALLS FOR MULTIPLE PIPE ARCHES

13" - 38" RISE

VIRGINIA DEPARTMENT OF TRANSPORTATION

VDOT

ROAD AND BRIDGE STANDARDS

REVISION DATE

SHEET 1 OF 1

101.25

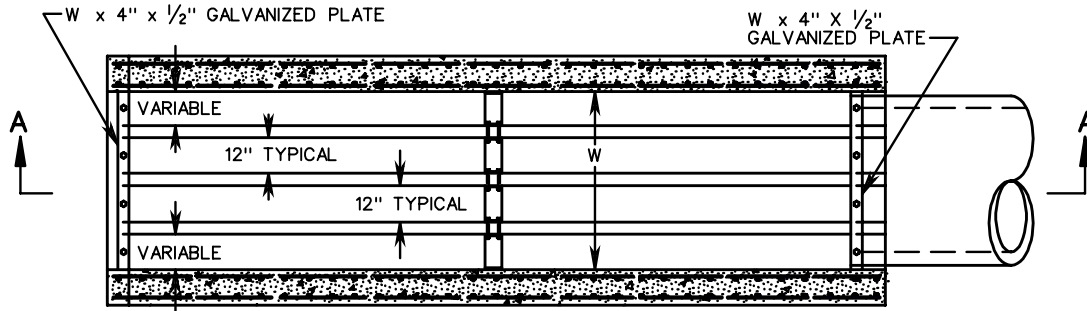

PLAN VIEW

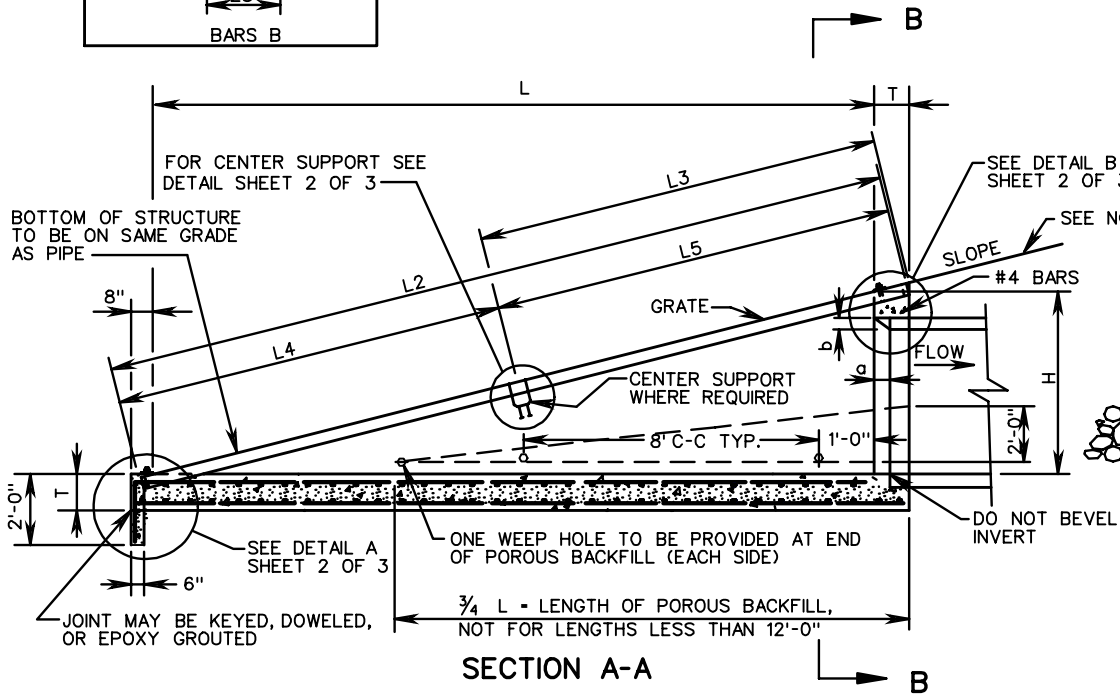
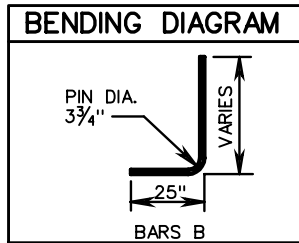

SECTION A-A

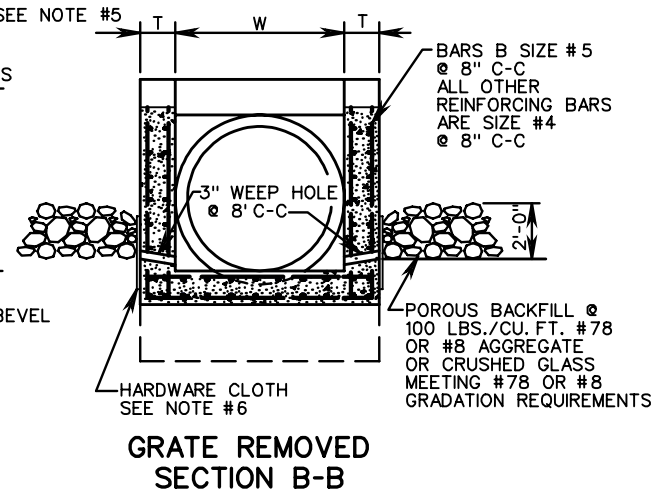

GRATE REMOVED SECTION B-B

NOTES:

1. THIS ITEM MAY BE PRECAST OR CAST IN PLACE. ALL CAST CONCRETE TO BE CLASS A3, FOR PRECAST USE 4000 PSI MINIMUM. REINFORCING STEEL TO HAVE A MINIMUM 1/2" COVER.
2. FOR TABULATION OF DIMENSIONS AND QUANTITIES SEE SHEET 3 OF 3.
3. ALL PIPE FOR GRATE, STRUCTURAL TUBING, AND RELATED HARDWARE TO BE GALVANIZED.
4. STANDARD EW-11 TO BE INSTALLED SO THE GRATE CONFIGURATION IS ALWAYS PERPENDICULAR TO THE EDGE OF THE SHOULDER.
5. SLOPE AS SPECIFIED ON TYPICAL SECTION.
6. WEEP HOLE WITH 12" X 12" PLASTIC HARDWARE CLOTH 1/4" MESH OR GALVANIZED STEEL WIRE, MINIMUM WIRE DIAMETER 0.03" NUMBER 4 MESH HARDWARE CLOTH ANCHORED FIRMLY OUTSIDE OF STRUCTURE.
7. HEADWALL TO BE BEVELED IN ALL AREAS EXCEPT WHERE A CONFLICT WITH INVERT OR WINGWALLS OCCUR.
8. BEVEL EDGE IS REQUIRED ON THE HEADWALL OF THE INLET END OF THE CULVERT (WHERE THE FLOW ENTERS THE CULVERT).
9. HEADWALL AT THE OUTLET END OF THE CULVERT MAY BE EITHER SQUARE EDGE OR BEVEL EDGE.
10. 3/4" CHAMFER MAY BE PROVIDED ON ALL EDGES AT MANUFACTURER'S OPTION.
11. IN NO CASE SHALL THE TOP OF THE ENDWALL PROJECT ABOVE FILL SLOPE, DITCH SLOPE OR SHOULDER



ROAD AND BRIDGE STANDARDS

PIPE ENDWALL WITH LOAD-CARRYING GRATE

SPECIFICATION REFERENCE

SHEET 1 OF 3

REVISION DATE

12" - 60" CIRCULAR PIPES

105
233
302

101.26

VIRGINIA DEPARTMENT OF TRANSPORTATION

* STRUCTURAL TUBING TO BE EXTENDED TO WITHIN 2" OF OUTSIDE FACE OF SIDEWALL

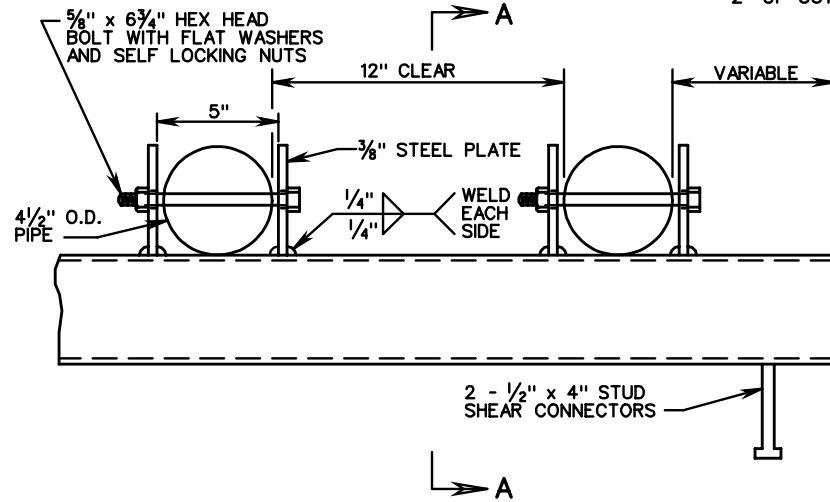

CENTER SUPPORT
(ELEVATION)

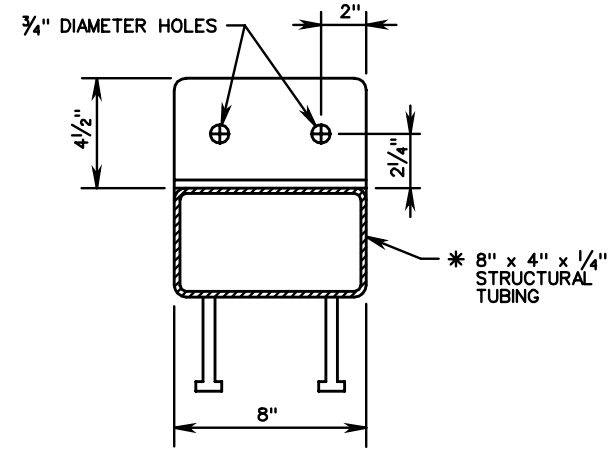

SECTION A-A

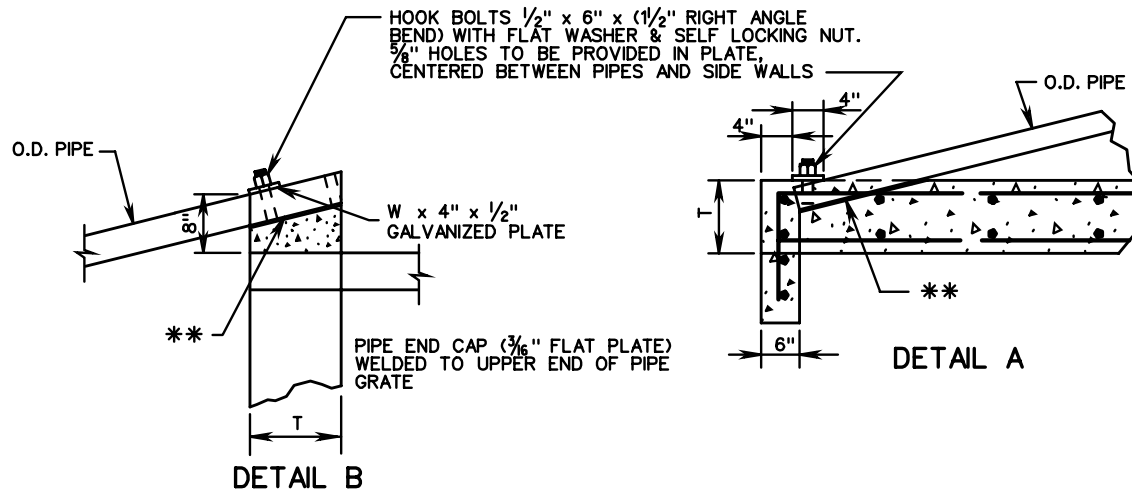

DETAIL B

DETAIL A

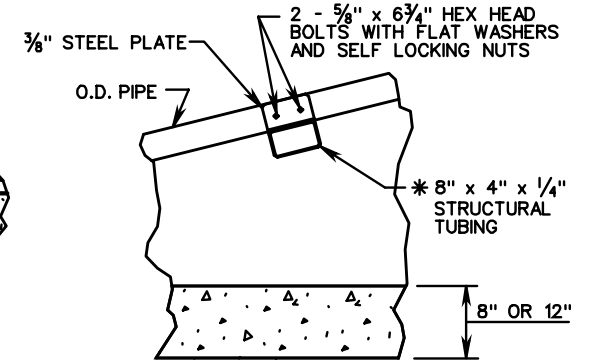

CENTER SUPPORT

** NOTCHES FOR PIPE TO BE FORMED IN CONCRETE SO THAT PIPE WILL FIT SNUG BUT CAN BE REMOVED.

SPECIFICATION REFERENCE

105
233
302

PIPE ENDWALL WITH LOAD-CARRYING GRATE

12" - 60" CIRCULAR PIPES

VIRGINIA DEPARTMENT OF TRANSPORTATION

VDOT

ROAD AND BRIDGE STANDARDS

REVISION DATE

SHEET 2 OF 3

101.27

PIPE GRATE

TYPE I - 3/2" O.D.
 TYPE II - 4" O.D.
 TYPE III - 4 1/2" O.D.

LENGTH OF GRATE TO BE DETERMINED
 BY L₂ x NUMBER OF PIPES REQUIRED

4 : 1 SLOPE

PIPE SIZE	H	L	W	T	4 : 1 SLOPE					
					PIPE O.D.	NO. PIPES REQUIRED	L ₂	L ₃	L ₄	L ₅
12"	1'-10"	7'-4"	2'-0"	8"	3 1/2"	1	8'-6 3/4"	NO CENTER SUPPORT REQUIRED		
15" or 18"	2'-4 1/2"	9'-6"	2'-0"	8"	3 1/2"	1	10'-9 1/2"			
21" or 24"	2'-11"	11'-8"	3'-0"	8"	4"	2	13'-0 1/4"			
27" or 30"	3'-5 1/2"	13'-10"	3'-0"	8"	4"	2	15'-3"			
33" or 36"	4'-0"	16'-0"	4'-0"	8"	4 1/2"	3	17'-6"			
42"	4'-6 1/2"	18'-2"	4'-0"	12"	4 1/2"	3	19'-8 3/4"			
48"	5'-1"	20'-4"	5'-0"	12"	4 1/2"	3	22'-2 5/8"	10'-5 1/4"	11'-10 1/2"	10'-4 1/4"
54"	5'-7 1/2"	22'-6"	6'-0"	12"	4 1/2"	4	24'-5 1/2"	12'-8 1/8"	11'-10 1/2"	12'-7 1/8"
60"	6'-2"	24'-8"	6'-0"	12"	4 1/2"	4	26'-8 1/2"	14'-11"	11'-10 1/2"	14'-10"

DIMENSIONS FOR BEVEL ON HEADWALL

PIPE I.D.	a	b
12"	0'-1 1/4"	0'-1"
15" or 18"	0'-2"	0'-1 1/2"
21" or 24"	0'-2 1/2"	0'-2"
27" or 30"	0'-3 1/4"	0'-2 1/2"
33" or 36"	0'-3 3/4"	0'-3"
42"	0'-4 1/2"	0'-3 1/2"
48"	0'-5"	0'-4"
54"	0'-5 3/4"	0'-4 1/2"
60"	0'-6 1/4"	0'-5"

6 : 1 SLOPE

PIPE SIZE	H	L	W	T	6 : 1 SLOPE					
					PIPE O.D.	NO. PIPES REQUIRED	L ₂	L ₃	L ₄	L ₅
12"	1'-10"	11'-0"	2'-0"	8"	3 1/2"	1	12'-1 1/4"	NO CENTER SUPPORT REQUIRED		
15" or 18"	2'-4 1/2"	14'-3"	2'-0"	8"	4"	1	15'-5 1/4"			
21" or 24"	2'-11"	17'-6"	3'-0"	8"	4 1/2"	2	18'-9"			
27" or 30"	3'-5 1/2"	20'-9"	3'-0"	8"	4 1/2"	2	22'-0"	4'-8 1/8"	17'-4 1/2"	4'-7 1/2"
33" or 36"	4'-0"	24'-0"	4'-0"	8"	4 1/2"	3	25'-3 3/8"	7'-11 5/8"	17'-4 1/2"	7'-11"
42"	4'-6"	27'-3"	4'-0"	12"	4 1/2"	3	28'-11"	11'-7 1/4"	17'-4 1/2"	11'-6 1/2"
48"	5'-1"	30'-6"	5'-0"	12"	4 1/2"	3	32'-2"	14'-10 3/4"	17'-4 1/2"	14'-10 1/8"
54"	5'-7 1/2"	33'-9"	6'-0"	12"	4 1/2"	4	35'-6"	18'-2 1/4"	17'-4 1/2"	18'-1 1/2"
60"	6'-2"	37'-0"	6'-0"	12"	4 1/2"	4	38'-9 1/2"	19'-5 1/2"	19'-4 3/4"	19'-4 3/4"

3 : 1 SLOPE

PIPE SIZE	H	L	W	T	PIPE GRATE			NO CENTER SUPPORT REQUIRED
					PIPE O.D.	NO. PIPES REQUIRED	L ₂	
12"	1'-10"	5'-6"	2'-0"	8"	3 1/2"	1	6'-9 1/2"	
15" or 18"	2'-4 1/2"	7'-1 1/2"	2'-0"	8"	3 1/2"	1	8'-6 1/4"	
21" or 24"	2'-11"	8'-9"	3'-0"	8"	3 1/2"	2	10'-2 3/4"	
27" or 30"	3'-5 1/2"	10'-4 1/2"	3'-0"	8"	3 1/2"	2	11'-11 1/4"	
33" or 36"	4'-0"	12'-0"	4'-0"	8"	4"	3	13'-7 3/4"	
42"	4'-6 1/2"	13'-7 1/2"	4'-0"	12"	4"	3	15'-4 1/4"	
48"	5'-1"	15'-3"	5'-0"	12"	4 1/2"	3	17'-0 1/2"	
54"	5'-7 1/2"	16'-10 1/2"	6'-0"	12"	4 1/2"	4	18'-9 1/2"	
60"	6'-2"	18'-6"	6'-0"	12"	4 1/2"	4	20'-6"	

APPROXIMATE QUANTITIES

PIPE SIZE	3 : 1			PIPE SIZE	4 : 1			PIPE SIZE	6 : 1		
	CONCRETE CUBIC YARDS		lbs. REINF. STEEL		CONCRETE CUBIC YARDS		lbs. REINF. STEEL		CONCRETE CUBIC YARDS		lbs. REINF. STEEL
	CONC. PIPE	C.M. PIPE			CONC. PIPE	C.M. PIPE			CONC. PIPE	C.M. PIPE	
12"	.95	.97	240	12"	1.17	1.18	308	12"	1.64	1.66	443
15" or 18"	1.27	1.29	328	15" or 18"	1.59	1.61	425	15" or 18"	2.28	2.31	618
21" or 24"	2.30	2.35	483	21" or 24"	2.44	2.49	628	21" or 24"	3.55	3.59	917
27" or 30"	2.38	2.44	608	27" or 30"	3.01	3.01	788	27" or 30"	4.35	4.41	1157
33" or 36"	3.28	3.38	809	33" or 36"	4.20	4.29	1059	33" or 36"	6.01	6.09	1556
42"	6.27	6.46	1050	42"	8.05	8.22	1368	42"	11.59	11.76	1997
48"	8.07	8.29	1327	48"	10.29	10.50	1647	48"	14.84	15.04	2514
54"	10.02	10.29	1612	54"	12.80	13.06	2105	54"	18.47	18.73	3094
60"	11.18	11.50	1826	60"	14.36	14.68	2391	60"	20.82	21.14	3517



ROAD AND BRIDGE STANDARDS

PIPE ENDWALL WITH LOAD-CARRYING GRATE

12" - 60" CIRCULAR PIPES

VIRGINIA DEPARTMENT OF TRANSPORTATION

SPECIFICATION REFERENCE

105
233
302

SHEET 3 OF 3

REVISION DATE

101.28

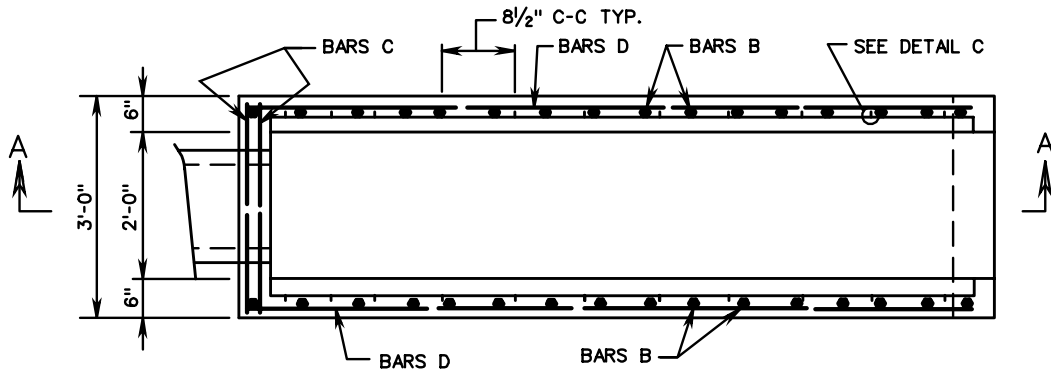

PLAN VIEW
(GRATE REMOVED)

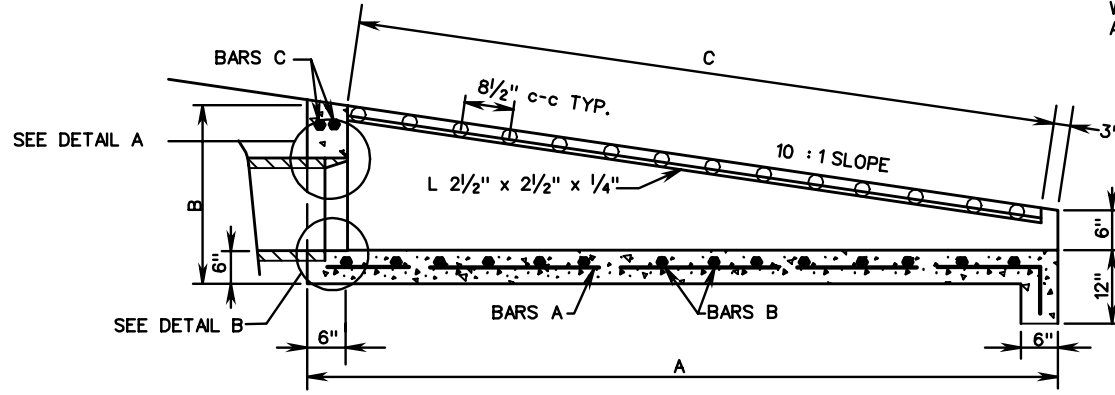

SECTION A-A

DIMENSIONS FOR BEVEL		
ON HEADWALL PIPE SIZE	a	b
12"	0'-1 1/4"	0'-1"
15"	0'-1 3/4"	0'-1 1/4"
18"	0'-2"	0'-1 1/2"
21" OR 24"	0'-2 1/2"	0'-2"

NO HOLES ARE TO BE PROVIDED IN L 2" x 2" x 3/8" WHEN SOLID BARS ARE USED.

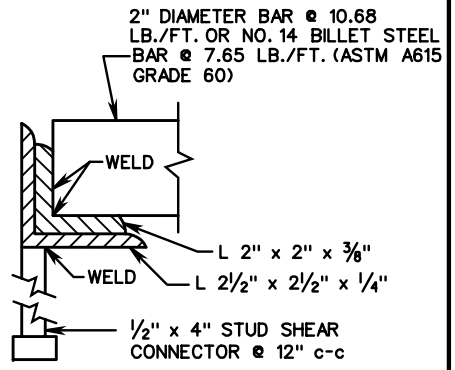

DETAIL C

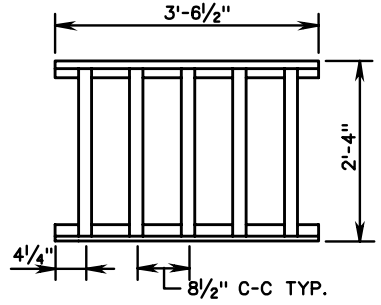

GRATE SECTION DETAIL

NOTES:

1. IN NO CASE SHALL TOP OF ENDWALL PROJECT ABOVE FILL SLOPE, DITCH, SLOPE, OR SHOULDER.
2. CLASS A3 CONCRETE TO BE USED IF CAST IN PLACE, 4000 PSI IF PRECAST.
3. REINFORCING STEEL TO HAVE A MINIMUM 1 1/2" CONCRETE COVER. FOR SCHEDULE OF REINFORCING STEEL, DIMENSIONS, AND QUANTITIES SEE SHEET 2 OF 2.
4. THIS ITEM MAY BE PRECAST OR CAST IN PLACE.
5. BOTTOM OF STRUCTURE TO BE ON THE SAME GRADE AS DRAINAGE DITCH.
6. 3/4" CHAMFER MAY BE PROVIDED ON ALL EDGES AT MANUFACTURER'S OPTION.
7. HEADWALL TO BE BEVELED IN ALL AREAS EXCEPT WHERE A CONFLICT WITH INVERT OR WINGWALLS OCCUR.
8. BEVEL EDGE IS REQUIRED ON HEADWALL AT THE INLET END OF THE CULVERT (WHERE THE FLOW ENTERS THE CULVERT). HEADWALL AT THE OUTLET END OF THE CULVERT MAY BE SQUARE EDGE OR BEVEL EDGE.
9. THE NUMBER OF GRATE SECTIONS TO BE USED FOR EACH EW-11A IS BASED ON THE LENGTH "C" SEE QUANTITIES CHART ON SHEET 2 OF 2.

SHAPE TO BE BEVELED WITH MORTAR

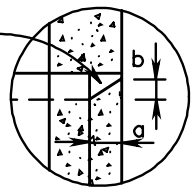

DETAIL A

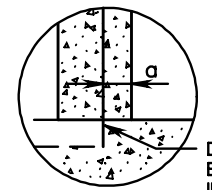

DETAIL B

SPECIFICATION REFERENCE
105 233 302

PIPE ENDWALL WITH LOAD-CARRYING GRATE
12" - 24" CIRCULAR PIPES
VIRGINIA DEPARTMENT OF TRANSPORTATION

VDOT ROAD AND BRIDGE STANDARDS	
REVISION DATE	SHEET 1 OF 2
101.29	

DIMENSIONS

PIPE SIZE	A	B	C	a	b
12"	11'-4"	2'-1"	10'-7½"	0'-1¼"	0'-1"
15"	14'-8"	2'-5"	14'-0"	0'-1¾"	0'-1¼"
18"	17'-2"	2'-8"	16'-6"	0'-2"	0'-1½"
21" OR 24"	22'-2"	3'-2"	21'-6½"	0'-2½"	0'-2"

APPROXIMATE QUANTITIES

PIPE SIZE	NO. OF GRATE SECTIONS	CONCRETE CUBIC YARDS		LBS. REINF. STEEL	LENGTH TO BE CUT FROM 1 GRATE
		CONC. PIPE	C.M. PIPE		
12"	3	1.127	1.139	119	0
15"	4	1.532	1.547	161	2½"
18"	5	1.856	1.877	201	1'-2½"
21" OR 24"	6	2.567	2.600	276	* 0

* GRATES WILL BE 3⅝" SHORT.

SCHEDULE OF REINFORCING STEEL

PIPE SIZE	BARS A				BARS B				BARS C				BARS D			
	SIZE	NO.	SPA.	LENGTH	SIZE	NO.	SPA.	LENGTH	SIZE	NO.	SPA.	LENGTH	SIZE	NO.	SPA.	LENGTH
12"	# 4	5	8"	11'-6"	# 4	17	8"	VARIES 3'-8" TO 5'-10"	# 4	2	-	4'-8"	# 4	4	8"	VARIES 4'-2" TO 11'-0"
15"	# 4	5	8"	14'-10"	# 4	22	8"	VARIES 3'-8" TO 6'-7"	# 4	2	-	4'-8"	# 4	4	8"	VARIES 7'-8" TO 14'-4"
18"	# 4	5	8"	17'-4"	# 4	26	8"	VARIES 3'-8" TO 7'-0"	# 4	2	-	4'-8"	# 4	6	8"	VARIES 4'-4" TO 16'-10"
21" OR 24"	# 4	5	8"	22'-4"	# 4	33	8"	VARIES 3'-8" TO 8'-0"	# 4	2	-	4'-8"	# 4	8	8"	VARIES 2'-9" TO 21'-10"

BENDING DIAGRAM

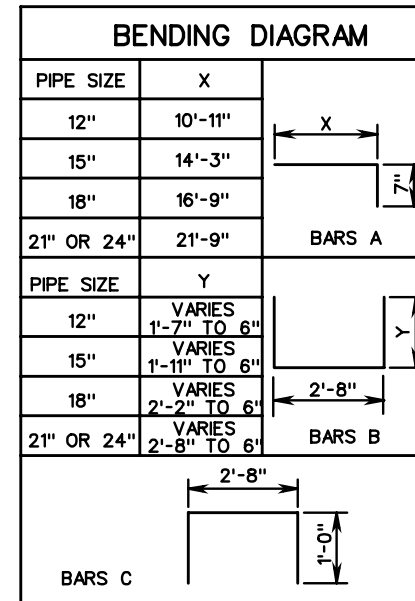

APPROXIMATE WEIGHT OF GRATE

TYPE	LBS.
2" DIA. BAR	158.55
NO. 14 BILLET STEEL BAR	123.64



ROAD AND BRIDGE STANDARDS

PIPE ENDWALL WITH LOAD-CARRYING GRATE

12" - 24" CIRCULAR PIPES

VIRGINIA DEPARTMENT OF TRANSPORTATION

SPECIFICATION REFERENCE

105
233
302

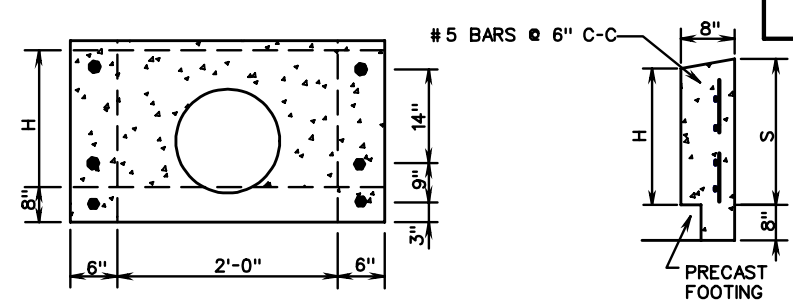
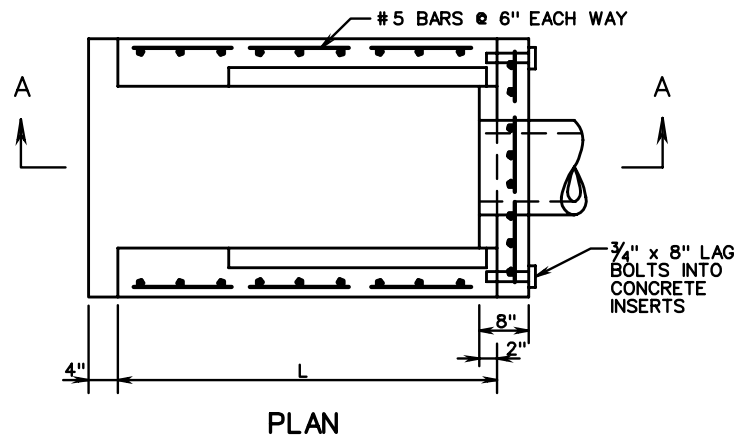

DIMENSIONS		
PIPE SIZE	H	S
12"	1'-7"	1'-7 3/4"
15"	1'-11"	1'-11 3/4"
18"	2'-2"	2'-2 3/4"
21" OR 24"	2'-8"	2'-8 3/4"

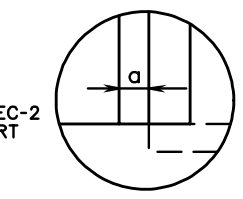
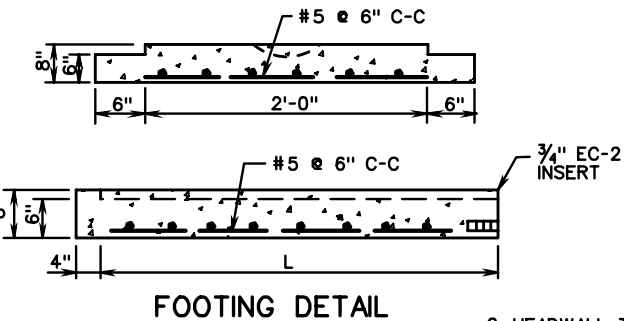
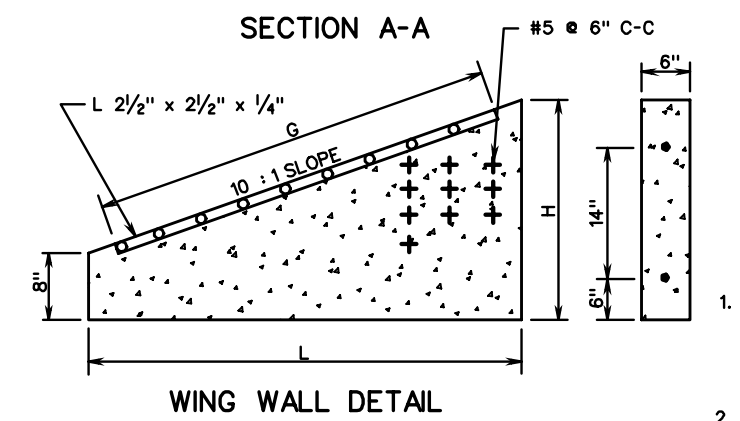
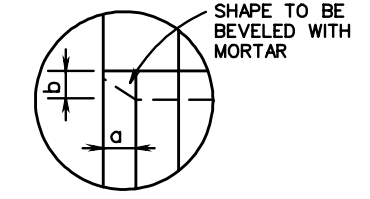
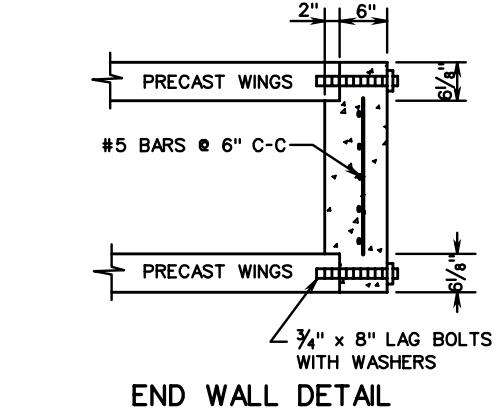
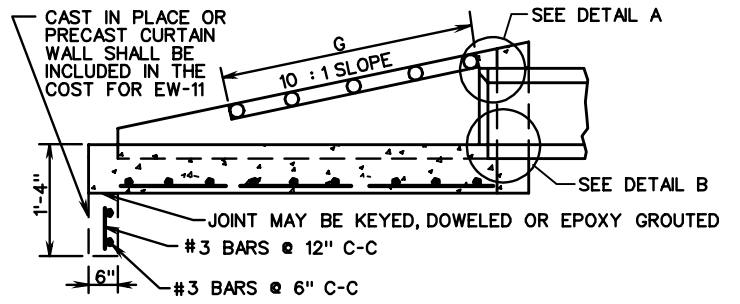

DIMENSIONS					
PIPE SIZE	L	H	G	a	b
12"	11'-0"	1'-9"	10'-7 1/2"	0'-1 1/4"	0'-1"
15"	14'-4"	2'-1"	14'-0"	0'-1 3/4"	0'-1 1/4"
18"	16'-10"	2'-4"	16'-6"	0'-2"	0'-1 1/2"
21" OR 24"	21'-10"	2'-10"	21'-6 1/2"	0'-2 1/2"	0'-2"

1. CONCRETE TO BE 4000 PSI MINIMUM COMPRESSIVE STRENGTH. IF PIPE IS TO BE SKEWED, THE OPENING WILL BE ADJUSTED TO ACCOMMODATE. REINFORCING STEEL IN ACCORDANCE WITH ASTM A615 (REINFORCING BARS).
2. PIPE DIMENSIONS SHOWN ARE MINIMUM. ACTUAL DIMENSIONS MAY VARY WITH MANUFACTURER.
3. BOTTOM OF STRUCTURE TO BE ON THE SAME GRADE AS DRAINAGE DITCH.
4. FOR DETAILS OF GRATE AND NUMBER OF GRATES REQUIRED SEE EW-11A.
5. 3/4" CHAMFER MAY BE PROVIDED ON ALL EDGES AT MANUFACTURER'S OPTION.
6. HEADWALL TO BE BEVELED IN ALL AREAS EXCEPT WHERE A CONFLICT WITH INVERT OR WINGWALLS OCCUR.
7. BEVEL EDGE IS REQUIRED ON THE HEADWALL AT THE INLET END OF THE CULVERT (WHERE THE FLOW ENTERS THE CULVERT).
8. HEADWALL AT THE OUTLET END OF THE CULVERT MAY BE EITHER SQUARE EDGE OR BEVEL EDGE.
9. PIPE OPENINGS IN PRECAST DRAINAGE UNITS SHALL NOT EXCEED 4 INCHES AT ANY GIVEN POINT BETWEEN THE PIPE AND THE PRECAST UNIT.

SPECIFICATION REFERENCE
105
233
302

PRECAST PIPE ENDWALL WITH LOAD-CARRYING GRATE
 12" - 24" CIRCULAR PIPES
 VIRGINIA DEPARTMENT OF TRANSPORTATION

VDOT ROAD AND BRIDGE STANDARDS	
REVISION DATE	SHEET 1 OF 1
101.31	

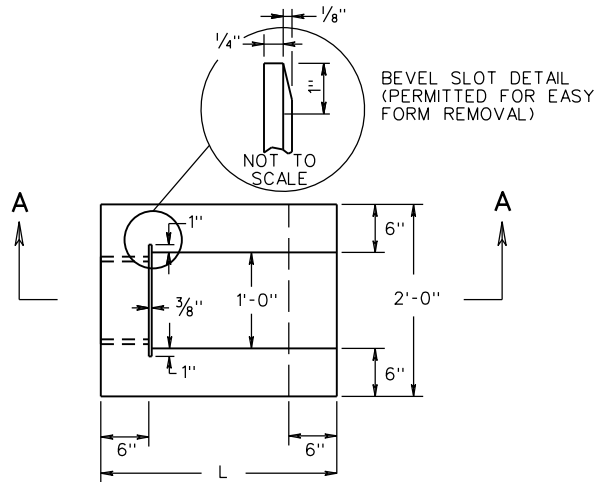

PLAN

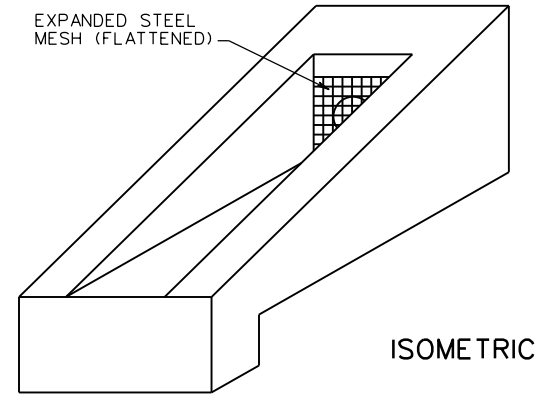

ISOMETRIC

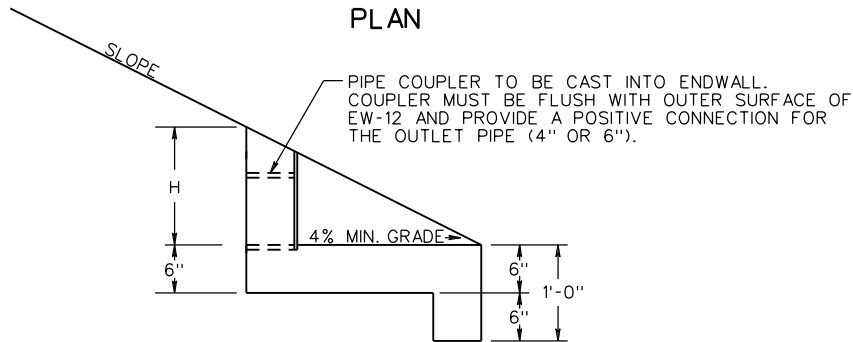

SECTION A-A

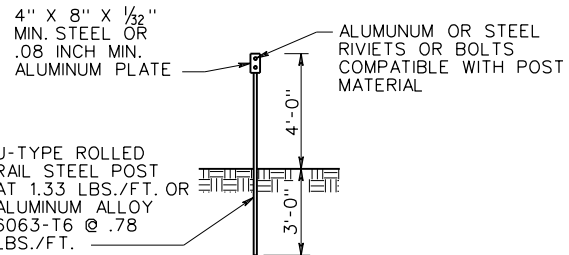

UNDERDRAIN OUTLET MARKER DETAIL

NOTES:

1. TYPICAL ENDWALL TO BE PLACED AT THE ENDS OF ALL UNDERDRAIN OUTLETS, BARRING LOCATIONS WHERE UNDERDRAIN IS TIED INTO OTHER DRAINAGE STRUCTURES. ENDWALL TO BE INSTALLED PERPENDICULAR TO ROADWAY AND FLUSH WITH THE SLOPE.
2. OUTLET PIPES SHALL BE RIGID NONPERFORATED, SMOOTH-BORE PIPE, MEETING THE REQUIREMENTS OF 70 PSITESTED ACCORDING TO ASTM 2412.
3. EXPANDED STEEL MESH (FLATTENED) SHALL HAVE OPENINGS OF APPROX. 1/2" X 1" AND WEIGH APPROX. 0.82 LBS. PER SQ. FT. MESH SHALL BE GALVANIZED IN ACCORDANCE WITH ASTM A-123. THE MESH SHALL EXTEND A MINIMUM OF 1" ABOVE THE O.D. OF THE PIPE, AND IS A BARRIER FOR RODENTS, ETC. THE SLOT FOR THE STEEL MESH IS TO BE CONSTRUCTED SO THAT THE MESH CAN BE REMOVED FOR CLEANOUT PURPOSES.
4. THIS ITEM MAY BE PRECAST OR CAST IN PLACE.
5. STEEL POSTS AND PLATES TO BE PAINTED OR GALVANIZED IN ACCORDANCE WITH THE ROAD AND BRIDGE SPECIFICATIONS. IF PAINTED THE FINAL COAT SHALL BE NO. 13 ALUMINUM PAINT OR NO. 11 WHITE PAINT.
6. MARKER TO BE PLACED AT ALL EW-12 UNDERDRAIN INSTALLATIONS.
7. MARKER WILL BE PAID FOR IN ACCORDANCE WITH SECTION 501 OF THE ROAD AND BRIDGE SPECIFICATIONS.

PIPE I.D.	SLOPE	DIMENSIONS		CLASS A3 CONCRETE CUBIC YARDS
		L	H	
4"	2:1	2'-5 1/2"	1'-2 3/4"	0.19
4"	3:1	3'-5 1/4"	1'-1 3/4"	0.25
4"	4:1	4'-5"	1'-1 1/4"	0.30
6"	2:1	2'-10 1/2"	1'-5 1/4"	0.20
6"	3:1	4'-3 1/4"	1'-4 1/4"	0.30
6"	4:1	5'-3"	1'-3 3/4"	0.38



ROAD AND BRIDGE STANDARDS

SHEET 1 OF 1

REVISION DATE

101.32

01/15

A COPY OF THE ORIGINAL SEALED AND SIGNED DRAWING IS ON FILE IN THE CENTRAL OFFICE.
STANDARD ENDWALL FOR PIPE UNDERDRAIN

VIRGINIA DEPARTMENT OF TRANSPORTATION

SPECIFICATION REFERENCE

105
233
302
501

END-SECTION 12" - 60" PIPE

HUB END ON OUTLET END-SECTIONS
SPIGOT END ON INLET END-SECTION

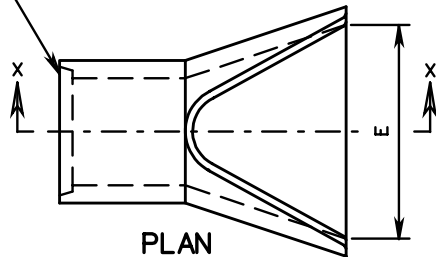

PLAN

CONCRETE TO BE
4000 PSI MINIMUM

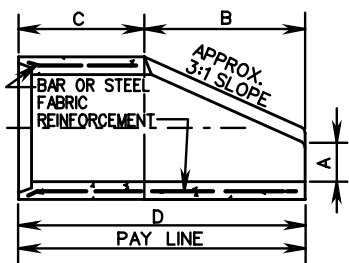

SECTION X-X

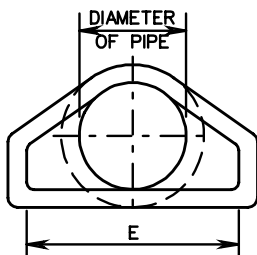

END VIEW

END SECTION DIMENSIONS

PIPE DIAMETER	A	B	C	D	E
12"	4"	2'-0"	2'-0"	4'-0"	2'-0"
15"	6"	2'-3"	1'-9"	4'-0"	2'-6"
18"	9"	2'-3"	1'-9"	4'-0"	3'-0"
21"	9 1/4"	2'-11"	2'-1"	5'-0"	3'-6"
24"	9 1/2"	3'-7"	2'-6"	6'-1"	4'-0"
27"	10 3/4"	4'-0"	2'-1"	6'-1"	4'-6"
30"	1'-0"	4'-6"	1'-7 3/4"	6'-1 3/4"	5'-0"
33"	1'-1 1/2"	4'-10 1/2"	2'-3 1/4"	7'-1 3/4"	5'-6"
36"	1'-3"	5'-3"	2'-10 3/4"	8'-1 3/4"	6'-0"
42"	1'-9"	5'-3"	2'-11"	8'-2"	6'-6"
48"	2'-0"	6'-0"	2'-2"	8'-2"	7'-0"
54"	2'-3"	5'-5"	2'-9 1/4"	8'-2 1/4"	7'-6"
60"	2'-11"	5'-0"	3'-3"	8'-3"	8'-0"

ALTERNATE END-SECTION 12" - 60" PIPE

HUB END ON OUTLET END-SECTIONS
SPIGOT END ON INLET END-SECTION

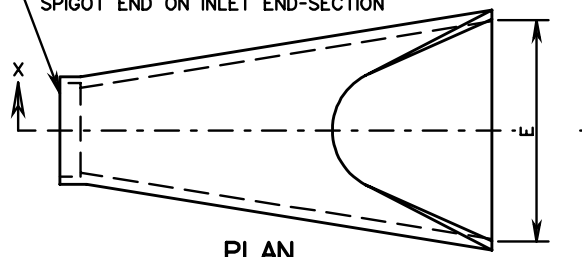

PLAN

CONCRETE TO BE
4000 PSI MINIMUM

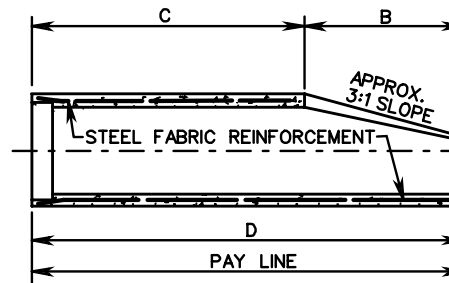

SECTION X-X

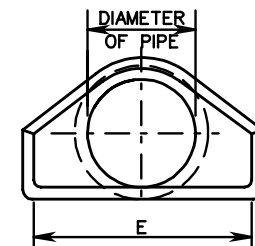

END VIEW

END SECTION DIMENSIONS

PIPE DIAMETER	A	B	C	D	E
12"	4"	2'-0"	4'-1"	6'-1"	2'-0"
15"	6"	2'-3"	3'-10"	6'-1"	2'-6"
18"	9"	2'-3"	3'-10"	6'-1"	3'-0"
21"	9"	2'-11"	3'-2"	6'-1"	3'-6"
24"	10"	3'-7"	2'-8"	6'-3"	4'-0"
27"	10 1/2"	4'-0"	2'-1 1/2"	6'-1 1/2"	4'-6"
30"	1'-0"	4'-6"	1'-7 3/4"	6'-1 3/4"	5'-0"
33"	1'-1 1/2"	4'-10 1/2"	2'-3 1/4"	8'-1 3/4"	5'-6"
36"	1'-3"	5'-3"	2'-10 3/4"	8'-1 3/4"	6'-0"
42"	1'-9"	5'-3"	2'-11"	8'-2"	6'-6"
48"	2'-0"	6'-0"	2'-2"	8'-2"	7'-0"
54"	2'-3"	5'-5"	2'-11"	8'-4"	7'-6"
60"	2'-6"	5'-0"	3'-3"	8'-3"	8'-0"

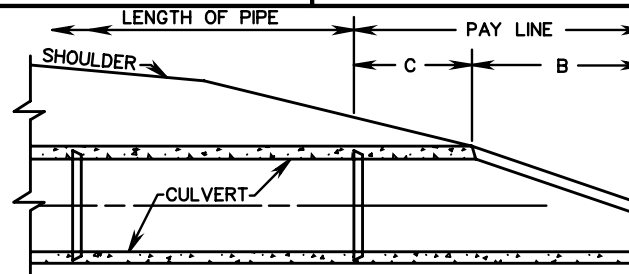

SLOPE DETAIL

NOTES:

PIPE LENGTHS SHOWN ON PLANS ARE BASED ON END-SECTION DESIGN SHOWN ON THE LEFT. IF THE CONTRACTOR ELECTS TO USE THE ALTERNATE DESIGN SHOWN ON THE RIGHT, LENGTHS WILL BE REDUCED BY THE DIFFERENCE IN DIMENSION "D".

SPECIFICATION REFERENCE

302

FLARED END SECTION
12" - 60" CONCRETE PIPE CULVERTS

VIRGINIA DEPARTMENT OF TRANSPORTATION

VDOT

ROAD AND BRIDGE STANDARDS

REVISION DATE

SHEET 1 OF 1

102.01

CONCRETE TO BE
4000 PSI MINIMUM

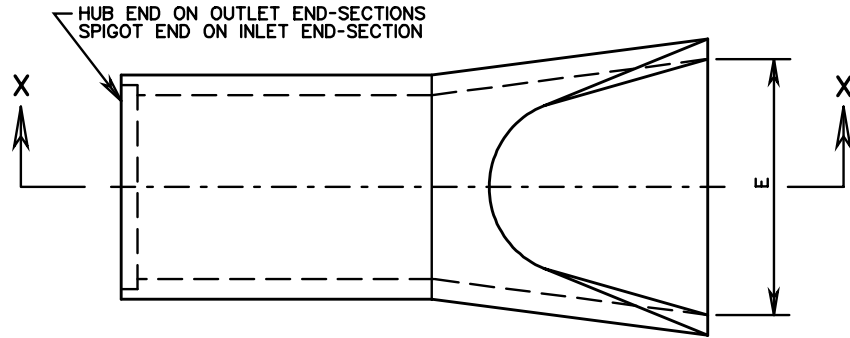

END SECTION DIMENSIONS

SPAN X RISE	A	B	C	L	E
23" X 14"	6"	2'-3"	3'-10"	6'-1"	2'-8"
30" X 19"	9"	2'-11"	3'-2"	6'-1"	3'-6"
38" X 24"	10"	3'-8"	2'-6"	6'-2"	4'-0"
42" X 27"	12"	4'-6"	1'-8"	6'-2"	5'-0"
45" X 29"	13"	4'-11"	3'-3"	8'-2"	5'-6"
53" X 34"	15"	5'-3"	2'-11"	8'-2"	6'-0"

PLAN

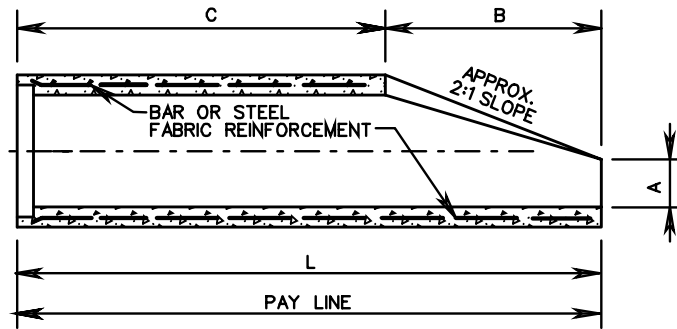

SECTION X-X

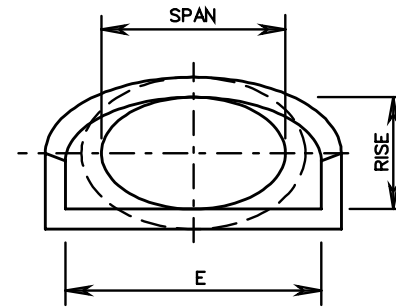

END VIEW

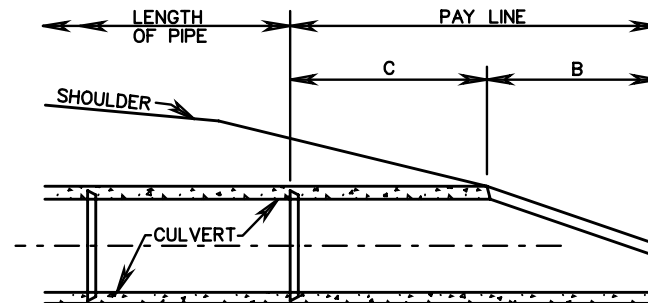

SLOPE DETAIL



ROAD AND BRIDGE STANDARDS

SHEET 1 OF 1

REVISION DATE

102.02

FLARED END-SECTION

23" x 14" TO 53" x 34" ELLIPTICAL CONCRETE PIPE CULVERTS

VIRGINIA DEPARTMENT OF TRANSPORTATION

SPECIFICATION
REFERENCE

302

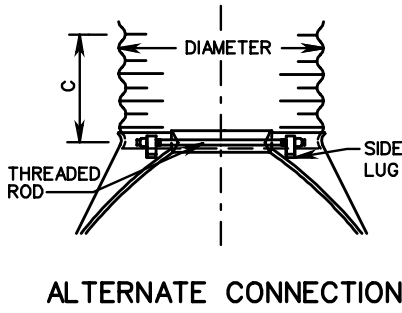
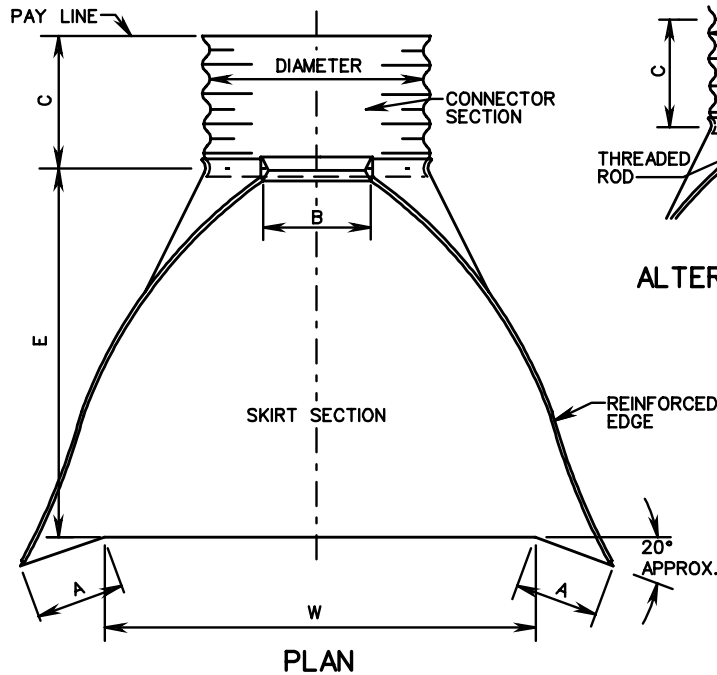

ALTERNATE CONNECTION

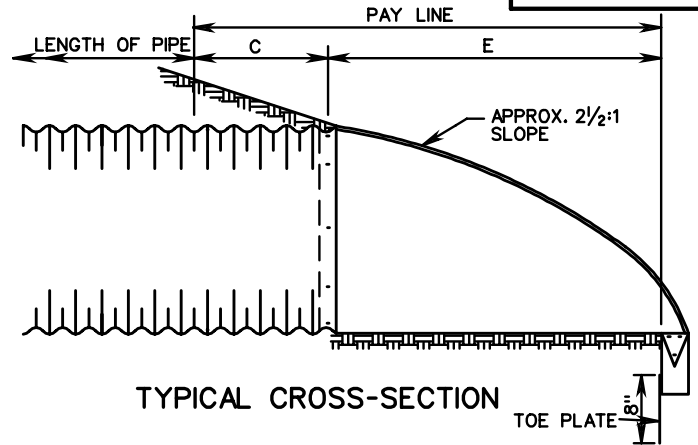

TYPICAL CROSS-SECTION

PIPE DIAMETER	SHEET THICKNESS		DIMENSIONS					
	STEEL	ALUMINUM	A 1" TOL.	B MAX.	H 1" TOL.	E 1/2" TOL.	W 2" TOL.	C
12"	.064"	.060"	6"	6"	6"	21"	24"	24"
15"	.064"	.060"	7"	8"	6"	26"	30"	24"
18"	.064"	.060"	8"	10"	6"	31"	36"	24"
21"	.064"	.060"	10"	12"	6"	36"	42"	24"
24"	.064"	.060"	10"	13"	6"	41"	48"	24"
27"/30"	.064"	.075"	12"	16"	8"	51"	60"	24"
36"	.064"	.075"	14"	19"	9"	60"	72"	36"
42"	.064"	.105"	16"	22"	11"	69"	84"	36"
48"	.064"	.105"	18"	27"	12"	78"	90"	24"
54"	.064"/.079"	.105"	18"	30"	12"	84"	102"	36"
60"	.064"/.079"	.105"/.135"	18"	33"	12"	87"	114"	36"

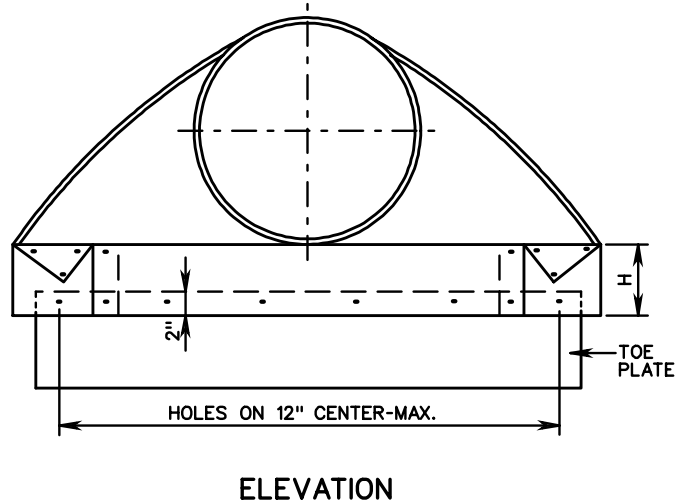

ELEVATION

NOTES:

1. TOE PLATE TO BE PUNCHED TO MATCH HOLES IN SKIRT LIP. 3/8" GALVANIZED BOLTS TO BE FURNISHED. LENGTH OF TOE PLATE IS W + 10" FOR 12" TO 30" DIAMETER PIPE AND W + 22" FOR 36" TO 60" DIAMETER PIPE.
2. SKIRT SECTION 12" TO 30" DIAMETER PIPE TO BE MADE IN ONE PIECE.
3. SKIRT SECTION FOR 36" TO 54" DIAMETER PIPE MAY BE MADE FROM TWO SHEETS JOINED BY RIVETING OR BOLTING ON CENTER LINE, 60" MAY BE CONSTRUCTED IN 3 PIECES.
4. CONNECTOR SECTION, CORNER PLATE AND TOE PLATE TO BE SAME SHEET THICKNESS AS SKIRT.
5. END-SECTION AND FITTINGS ARE TO BE STEEL FOR USE WITH STEEL PIPE.
6. END-SECTION AND FITTINGS ARE TO BE ALUMINUM ALLOY FOR USE WITH ALUMINUM ALLOY PIPE.
7. EITHER THE STEEL OR ALLUMINUM END-SECTION DETAILED MAY BE USED FOR PLASTIC PIPE SIZES SHOWN IN ST'D. PC-1 OR AN APPROVED PLASTIC END-SECTION MAY BE USED.
8. WHERE FLARED END-SECTION ARE TO BE USED WITH ASPHALT COATED AND PAVED METAL PIPE, END SECTIONS DO NOT NEED TO BE COATED OR PAVED.

SPECIFICATION REFERENCE	302	<h2 style="text-align: center;">FLARED END SECTION</h2> <h3 style="text-align: center;">12" - 60" CORRUGATED PIPE CULVERTS</h3> <p style="text-align: center;">VIRGINIA DEPARTMENT OF TRANSPORTATION</p>	<p>ROAD AND BRIDGE STANDARDS</p>	
			REVISION DATE	SHEET 1 OF 1 102.03

ALTERNATE CONNECTION

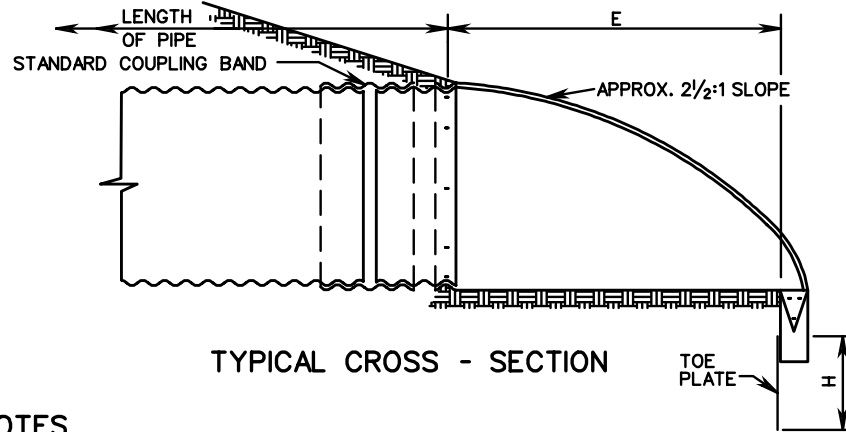
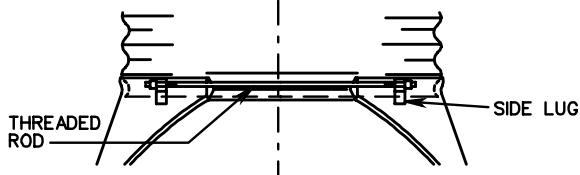

TYPICAL CROSS - SECTION

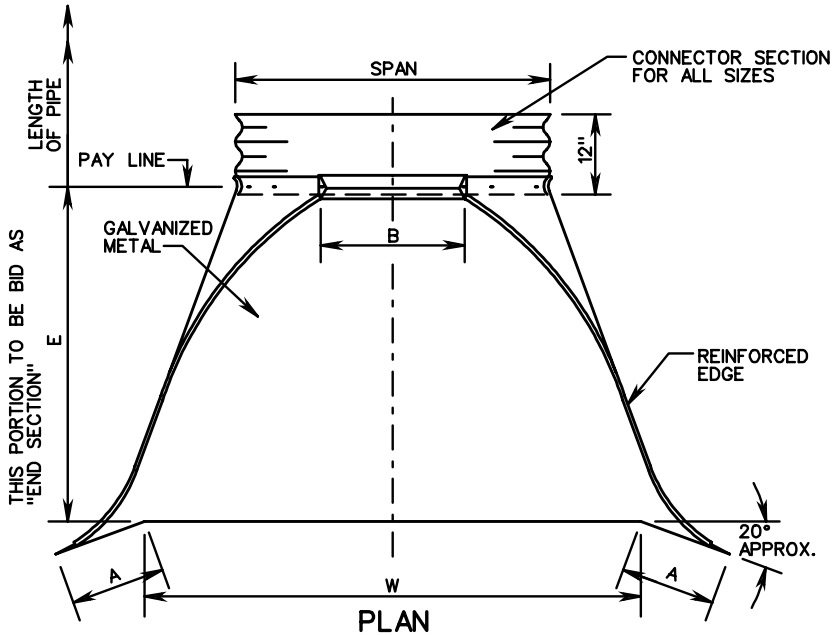

PLAN

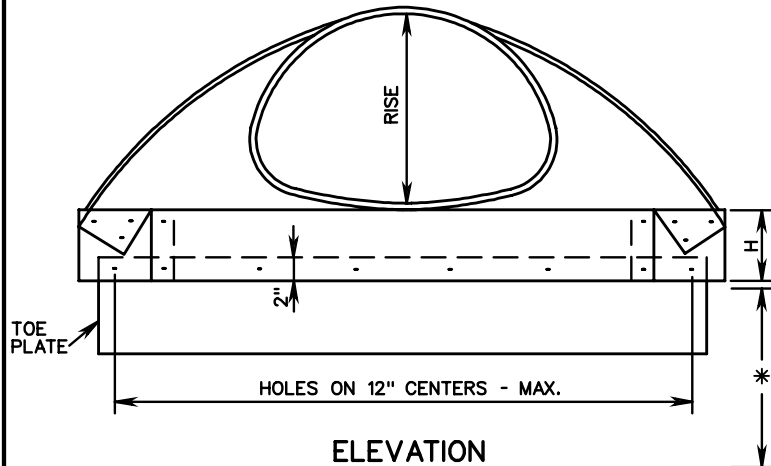

ELEVATION

NOTES

1. TOE PLATE TO BE PUNCHED TO MATCH HOLES IN SKIRT LIP.
2. 3/8" GALVANIZED BOLTS TO BE FURNISHED, LENGTH OF TOE PLATE IS W + 10" WITH RISE OF 13" TO 29" INCLUDED AND W + 18" MIN. WITH RISE OF 33" TO 47" INCLUDED.
3. SKIRT SECTION WITH RISE OF 13" TO 24" INCLUDED TO BE MADE IN ONE PIECE.
4. SKIRT SECTION WITH RISE OF 29" TO 38" INCLUDED MAY BE MADE FROM TWO SHEETS JOINED BY RIVETING OR BOLTING ON CENTER LINE.
5. SKIRT SECTION WITH RISE OF 43" TO 47" INCLUDED MAY BE MADE FROM THREE SHEETS JOINED BY RIVETING OR BOLTING AT EQUAL DISTANCES FROM CENTER LINE.
6. CONNECTOR SECTION, CORNER PLATE AND TOE PLATE TO BE SAME SHEET THICKNESS AS SKIRT AND SAME TYPE OF MATERIAL AS CULVERT.
7. WHERE FLARED END - SECTIONS ARE TO BE USED WITH ASPHALT COATED AND PAVED METAL PIPE, END SECTIONS DO NOT NEED TO BE COATED OR PAVED.
8. * INDICATES PIPE ARCHES FOR WHICH DIMENSIONS FOR EITHER CORRUGATION MAY BE USED WITHIN FILL HEIGHT LIMITATIONS.

PIPE-ARCH DIMENSIONS											
3" x 1" and 5" x 1" CORRUGATIONS			2 2/3" x 1/2" CORRUGATIONS				DIMENSIONS				
SPAN	RISE	SHEET THICKNESS	SPAN	RISE	SHEET THICKNESS		1" TOL.	MAX.	1" TOL.	1 1/2" TOL.	2" TOL.
					STEEL	ALUM.					
			17"	13"	.064"	.060	4 1/2"	9"	6"	19"	30"
			21"	15"	.064"	.060	5 1/4"	10"	6"	23"	36"
			24"	18"	.064"	.060	6 1/4"	11 1/2"	6"	28"	42"
			28"	20"	.064"	.060	7"	14"	6"	31 1/2"	48"
			35"	24"	.064"	.075	8 3/4"	16"	6"	38 1/2"	60"
40"	31"	.079"	42"	29"	.064"	.105	10 3/4"	17 1/2"	7 5/8"	47"	75"
46"	36"	.079"	49"	33"	.109"	.105	12 1/4"	20"	9 1/8"	54"	85"
53"	41"	.079"	57"	38"	.109"	.105	14"	22"	10 5/8"	63"	96"
60"	46"	.079"	64"	43"	.109"	.105	15 3/4"	23"	10 5/8"	70"	112"
66"	51"	.079"	71"	47"	.138"	.135	17 1/4"	24"	12 1/8"	77"	128"



ROAD AND BRIDGE STANDARDS

SHEET 1 OF 1

REVISION DATE

102.04

FLARED END-SECTION

13" - 47" RISE METAL PIPE ARCHES

VIRGINIA DEPARTMENT OF TRANSPORTATION

SPECIFICATION REFERENCE

302

THIS PAGE INTENTIONALLY LEFT BLANK

SPECIFICATION
REFERENCE

VIRGINIA DEPARTMENT OF TRANSPORTATION



ROAD AND BRIDGE STANDARDS

REVISION DATE

SHEET 1 OF 1

102.05

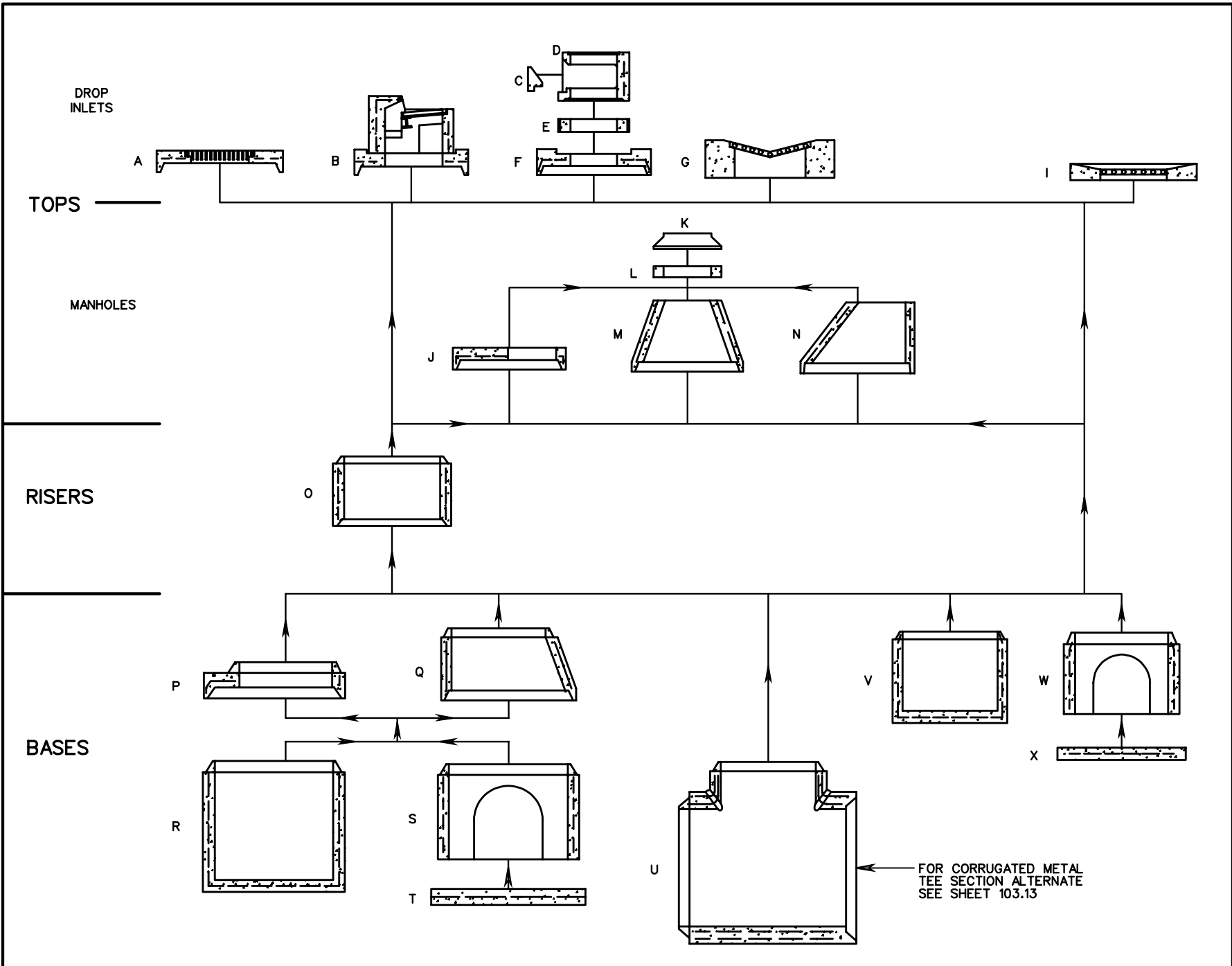

ROAD AND BRIDGE STANDARDS

PRECAST UNIT ASSEMBLY DIAGRAM

SPECIFICATION REFERENCE

SHEET 1 OF 1

REVISION DATE

VIRGINIA DEPARTMENT OF TRANSPORTATION

103.01

LEGEND

PAGE

A - FLAT SLAB TOP WITH FRAME AND GRATE (T-DI-1) _____ 103.03
 B - DROP INLET TOP UNIT (T-DI-2) _____ 103.04
 C - THROAT FACE BLOCK (T-DI-3,4) _____ 103.05, 103.06
 D - CURB DROP INLET THROAT SECTION (T-DI-3,4) _____ 103.05, 103.06
 E - SPACER UNIT (T-MH-2) _____ 103.09
 F - FLAT SLAB TOP WITH HOLE (T-MH-2) _____ 103.09
 G - DROP INLET TOP UNIT (T-DI-5) _____ 103.07
 I - DROP INLET TOP UNIT (T-DI-7) _____ 103.08
 J - FLAT SLAB TOP UNIT (T-MH-2) _____ 103.09
 K - MANHOLE FRAME AND COVER (T-MH-1) _____ 106.02 THRU 106.06
 L - SPACER UNIT (T-MH-2) _____ 103.09
 M - CONCENTRIC TAPER UNIT (T-MH-2) _____ 103.09
 N - ECCENTRIC TAPER UNIT (T-MH-2) _____ 103.09
 O - RISER UNIT (R-1) _____ 103.10
 P - FLAT SLAB REDUCER (R-2) _____ 103.10
 Q - TAPER REDUCER (R-3) _____ 103.10
 R - MONOLITHIC BASE UNIT - OVER 4' DIA. (B-1) _____ 103.11
 S - DOGHOUSE BASE UNIT - OVER 4' DIA. (B-2) _____ 103.11
 T - FOOTING (B-2) _____ 103.11
 U - TEE SECTION BASE UNIT (B-3) _____ 103.12
 V - MONOLITHIC BASE UNIT - OVER 4' DIA. (B-1) _____ 103.11
 W - DOGHOUSE BASE UNIT - OVER 4' DIA. (B-2) _____ 103.11
 X - FOOTING (B-2) _____ 103.11
 ALTERNATE JOINT DETAIL _____ 103.03

GENERAL NOTES - PRECAST

PRECAST STRUCTURES WILL CONFORM TO SECTION 302 OF THE SPECIFICATIONS. THE MANUFACTURER WILL HAVE THE OPTION OF SELECTING THE COMBINATION OF PRECAST UNITS TO COMPLETE A STRUCTURE UNLESS OTHERWISE NOTED ON THE PLANS.

THE "H" (LINEAR FEET FOR MANHOLES) DIMENSION SHOWN ON THE STANDARDS AND SPECIFIED ON THE PLANS WILL BE MEASURED FROM THE INVERT OF THE OUTFALL PIPE TO THE TOP OF THE MASONRY STRUCTURE. PLAN "H" DIMENSIONS ARE APPROXIMATE ONLY FOR ESTIMATING PURPOSES AND THE ACTUAL DIMENSIONS SHALL BE DETERMINED BY THE CONTRACTOR FROM FIELD CONDITIONS.

IN THE EVENT THE INVERT OF THE OUTFALL PIPE IS HIGHER THAN THE BOTTOM OF THE STRUCTURE, THE INVERT OF THE STRUCTURE SHALL BE SHAPED WITH CEMENT MORTAR TO PREVENT STANDING OR PONDING OF WATER IN THE STRUCTURE. THIS WILL APPLY TO ALL STRUCTURES MEETING THIS CONDITION AND IS NOT TO BE CONFUSED WITH STANDARD IS-1 THE COST FOR INVERT SHAPING SHALL BE INCLUDED IN THE PRICE BID FOR THE STRUCTURE.

WHEN SPECIFIED ON THE PLANS THE INVERT IS TO BE SHAPED IN ACCORDANCE WITH STANDARD IS-1. THE COST OF FURNISHING AND PLACING ALL MATERIALS INCIDENTAL TO THE SHAPING IS TO BE INCLUDED IN THE PRICE BID FOR THE STRUCTURE.

ALL PRECAST STRUCTURES TO BE CONSTRUCTED WITH 4000 PSI MINIMUM CONCRETE.

STEPS IN ACCORDANCE WITH STANDARD ST-1 ARE TO BE PROVIDED IN ALL MANHOLES AND IN ALL DROP INLETS WITH AN "H" DIMENSION OF 4'-0" OR GREATER.

3" DIAMETER WEEP HOLES WILL BE REQUIRED IN PRECAST STRUCTURE'S LOCATED ADJACENT TO THE PAVEMENT TO DRAIN THE SUBBASE. PLACEMENT OF WEEP HOLES IN THE PRECAST UNIT WILL BE DETERMINED BY THE PROXIMITY OF THE STRUCTURE TO THE SUBBASE. WEEP HOLES MAY ALSO BE REQUIRED IN OTHER STRUCTURES WHEN CALLED FOR ON THE PLANS OR DIRECTED BY THE ENGINEER.

WEEP HOLES WILL HAVE 12" X 12" PLASTIC HARDWARE CLOTH, 1/4" MESH OR GALVANIZED STEEL WIRE, MINIMUM WIRE DIAMETER 0.03", NUMBER 4 MESH HARDWARE CLOTH ANCHORED FIRMLY TO OUTSIDE OF STRUCTURE.

PRECAST UNITS LOCATED ADJACENT TO CAST-IN-PLACE CONCRETE ITEMS, SUCH AS FLUMES, DITCHES, GUTTERS, AND SIDEWALKS SHALL BE CONNECTED TO THE ADJACENT UNIT BY MEANS OF NO. 4 SMOOTH STEEL DOWELS SPACED ON APPROXIMATELY 12" CENTERS THROUGHOUT THE CONTACT LENGTH AND EXTENDING AT LEAST 4" INTO BOTH THE PRECAST UNIT TO RECEIVE THE DOWELS, THEY SHALL NOT EXCEED 5/8" DIAMETER.

THE STANDARD SAFETY SLAB (SL-1) IS TO BE USED ONLY WHEN SPECIFIED IN THE PLANS ON THE DRAINAGE SUMMARY SHEET AND/OR THE DRAINAGE DESCRIPTION. REFER TO STANDARD SL-1 FOR SAFETY SLAB INFORMATION.

3/4" CHAMFER MAY BE PROVIDED ON ALL EDGES AT MANUFACTURER'S OPTION.

SPECIFICATION REFERENCE

GENERAL NOTES - PRECAST

VIRGINIA DEPARTMENT OF TRANSPORTATION

 ROAD AND BRIDGE STANDARDS	
REVISION DATE	SHEET 1 OF 1
07/12	103.02

T-DI-1

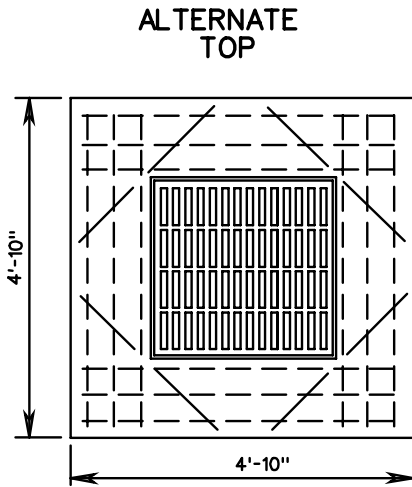
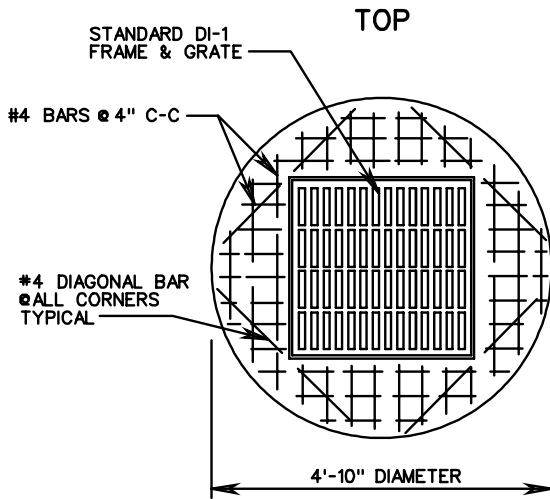

PIPE SIZE	H DIMENSION	
	CONCRETE	CORR. METAL
12"	2'-6"	2'-5"
15"	2'-9 ¹ / ₄ "	2'-8"
18"	3'-0 ¹ / ₂ "	2'-11"
21"	3'-3 ³ / ₄ "	3'-2"
24"	3'-7"	3'-5"

DI-1, 1A PC

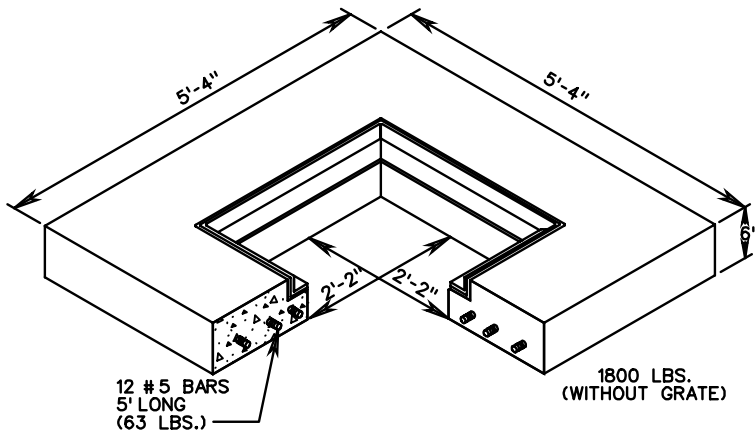

NOTES:

1. SEE GENERAL NOTES PRECAST FOR ADDITIONAL DETAILS.
2. CONCRETE TO BE 4000 PSIMINIMUM.
3. REINFORCING STEEL IN ACCORDANCE WITH ASTM C-478, ASTM A-497 (WIRE FABRIC) AND ASTM A-615 (REINFORCING BARS).
4. CONCRETE COVER AND GRATE ARE TO BE FURNISHED AS A SINGLE UNIT.
5. SEE STANDARD DI-1, 1A FOR DETAILS OF FRAME AND GRATE.
6. DIMENSIONS SHOWN ARE MINIMUM. ACTUAL DIMENSIONS MAY VARY WITH MANUFACTURER.

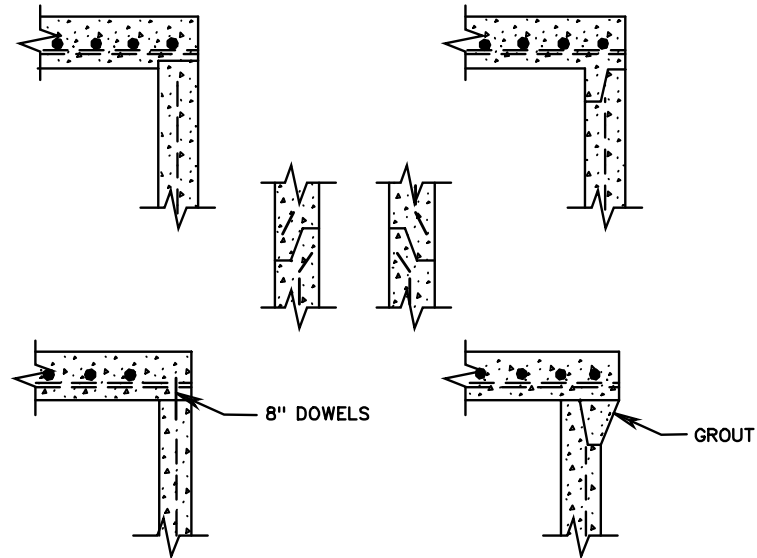

NOTES:

1. TONGUE AND GROOVE JOINT TO BE OF FABRICATOR'S DESIGN MEETING THE APPROVAL OF THE ENGINEER. JOINTS ARE TO BE SEALED WITH MORTAR, OR O-RING GASKETS OR BUTYL RUBBER.
2. ALTERNATE JOINT DETAILS APPLY TO ALL PRECAST UNITS.

ALTERNATE JOINT DETAILS



ROAD AND BRIDGE STANDARDS

SHEET 1 OF 1

REVISION DATE

103.03

STANDARD PRECAST TOP UNITS

VIRGINIA DEPARTMENT OF TRANSPORTATION

SPECIFICATION REFERENCE

105
233
302

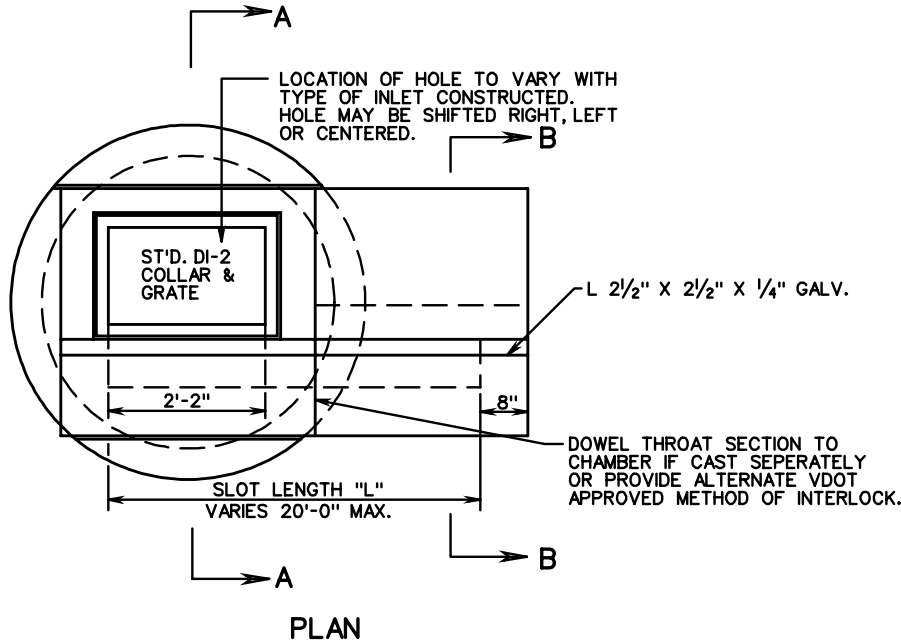

RECOMMENDED MINIMUM HEIGHT CHART	
PIPE SIZE	"H" DIMENSION (CONCRETE PIPE)
12"	4'-8"
15"	4'-11 1/4"
18"	5'-2 1/2"
21"	5'-5 3/4"
24"	5'-9"
27"	6'-0 1/4"
30"	6'-6 1/2"
33"	6'-9 3/4"
36"	7'-1"
42"	7'-7 1/2"
48"	8'-2"

NOTES

1. SEE GENERAL NOTES - PRECAST FOR ADDITIONAL DETAILS.
2. CONCRETE TO BE 4000 PSIMUMUM.
3. REINFORCING STEEL IN ACCORDANCE WITH ASTM-615.
4. DIMENSIONS SHOWN ARE MINIMUM. ACTUAL DIMENSIONS MAY VARY WITH MANUFACTURER.
5. FOR DETAILS OF FRAME AND GRATE SEE STANDARD DI-2A, B, C.
- * 6. VERTICAL REINFORCING BARS TO BE CONTINUOUS THROUGH JOINT.
7. STANDARD ST-1 STEPS NOT REQUIRED IN THIS TOP UNIT.

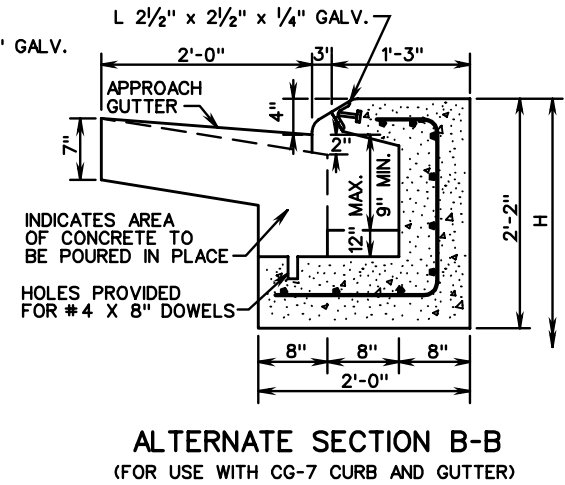
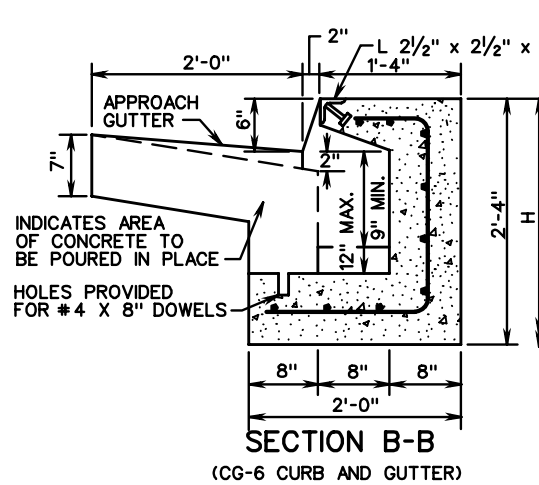
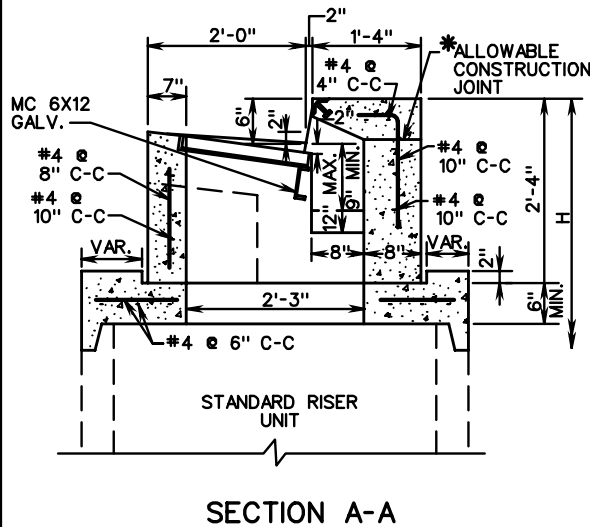

SPECIFICATION REFERENCE
105
233
302

STANDARD PRECAST TOP UNITS

VIRGINIA DEPARTMENT OF TRANSPORTATION

VDOT ROAD AND BRIDGE STANDARDS	
REVISION DATE	SHEET 1 OF 1
103.04	

CURB DROP INLET THROAT SECTION

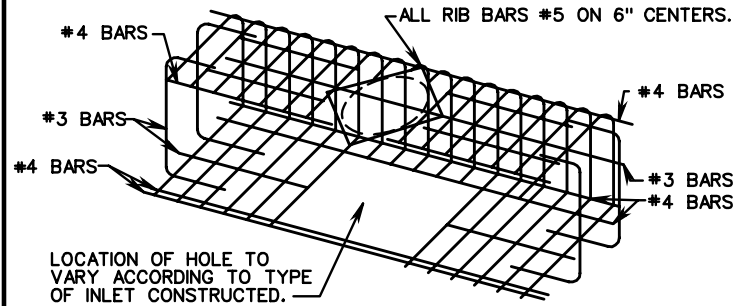
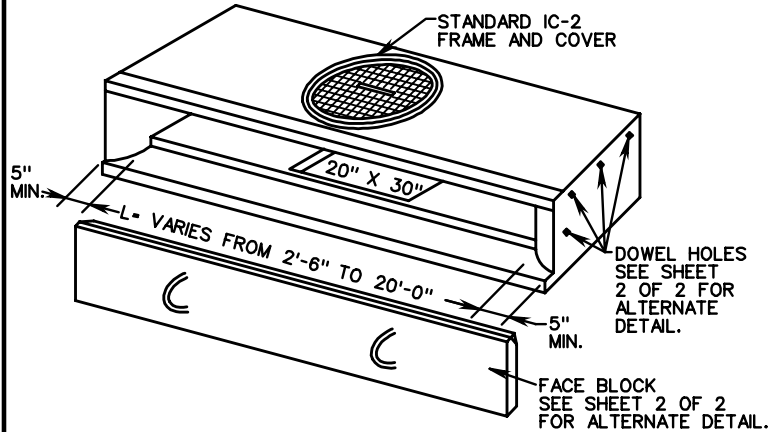

TYPICAL MINIMUM BAR REINFORCEMENT

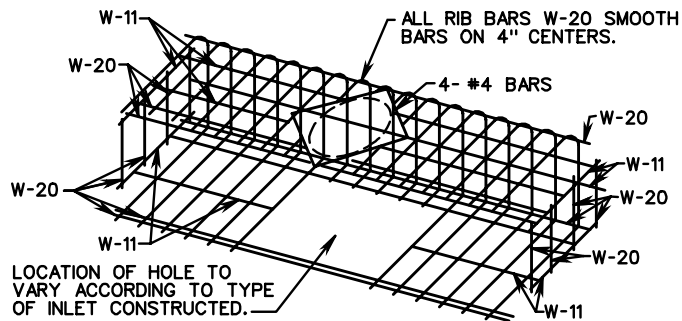

TYPICAL MINIMUM WELDED WIRE REINFORCEMENT

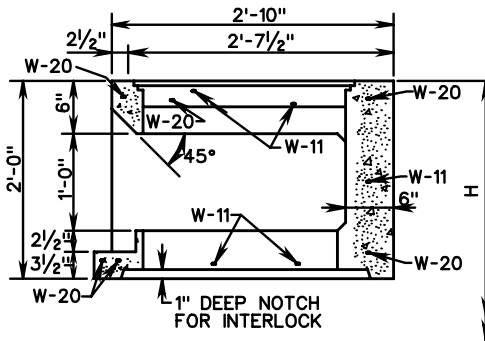
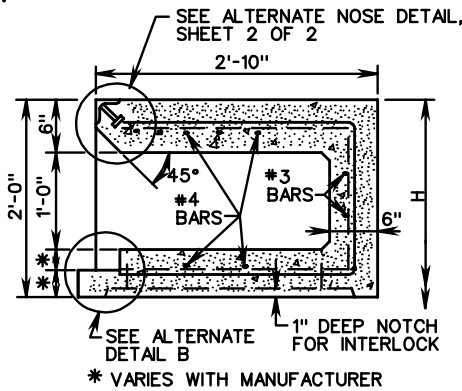

NOTES:

1. SEE GENERAL NOTES - PRECAST FOR ADDITIONAL DETAILS.
2. CONCRETE TO BE 4000 PSI MINIMUM COMPRESSIVE STRENGTH.
3. REINFORCING STEEL IN ACCORDANCE WITH ASTM A-615 FOR REINFORCING BARS.
4. REINFORCING IN ACCORDANCE WITH ASTM A-185 FOR WELDED WIRE MESH.
5. DIMENSIONS SHOWN ARE MINIMUM. ACTUAL DIMENSIONS MAY VARY WITH MANUFACTURER.
6. THIS UNIT MAY BE USED WITH ALL STANDARD DI-3 & DI-4 CURB DROP INLETS.
7. EACH FACE BLOCK SHALL HAVE 2 OR MORE LOOPS (#3 BARS) CAST IN FACE AS SHOWN. THESE LOOPS MAY BE USED FOR LIFT, AND FOR TIEING IN THE POURED IN PLACE GUTTER SECTION. FACE BLOCKS ARE TO BE SEALED WITH GROUT OR POLYSULFIDE SEALER.
8. STANDARD ST-1 STEPS NOT REQUIRED IN THIS TOP UNIT.

RECOMMENDED MINIMUM HEIGHT CHART

DI-3A,B,C, FOR 36" I.D. BASE UNIT	PIPE SIZE	H DIMENSION CONCRETE PIPE
	6"	2'-11"
8"	3'-1 1/4"	
10"	3'-3 3/4"	
12"	3'-6"	
15"	3'-9 1/4"	
18"	4'-0 1/2"	
21"	4'-3 3/4"	
DI-3A,B,C,D,E,&F FOR 48" I.D. BASE UNIT	6"	3'-9"
	8"	3'-11 1/4"
	10"	4'-1 1/4"
	12"	4'-4"
	15"	4'-7 1/4"
	18"	4'-10 1/2"
	21"	5'-1 3/4"
24"	5'-5"	
27"	5'-8 1/4"	
DI-3A,B,C,D,E,&F FOR 60" OR 72" I.D. BASE UNITS & DI-4A,B,C,D,E,&F	12"	4'-4"
	15"	4'-7 1/4"
	18"	4'-10 1/2"
	21"	5'-1 3/4"
	24"	5'-5"
	27"	5'-8 1/4"
	30"	6'-2 3/4"
	33"	6'-5 3/4"
	36"	6'-9"
	42"	7'-3 1/2"
48"	7'-10"	



ROAD AND BRIDGE STANDARDS

SHEET 1 OF 2

REVISION DATE

103.05

STANDARD PRECAST TOP UNITS

VIRGINIA DEPARTMENT OF TRANSPORTATION

SPECIFICATION
REFERENCE

105
233
302

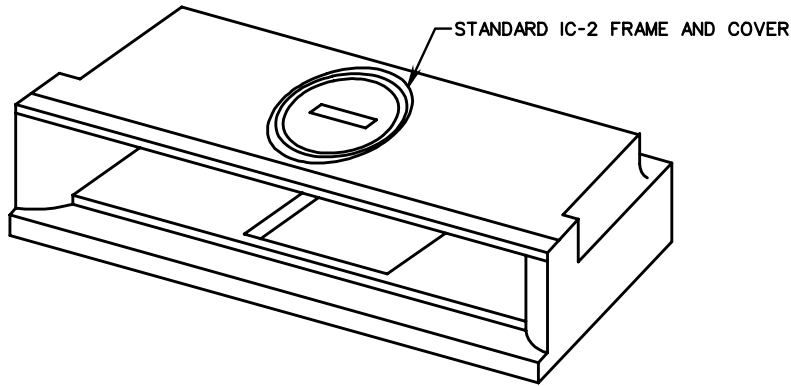

ISOMETRIC CURB DROP INLET THROAT SECTION ALTERNATE DESIGN

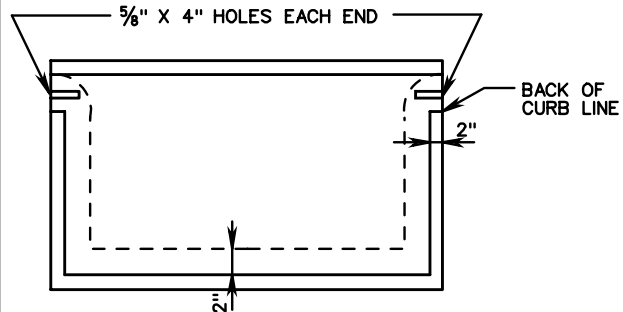

PLAN

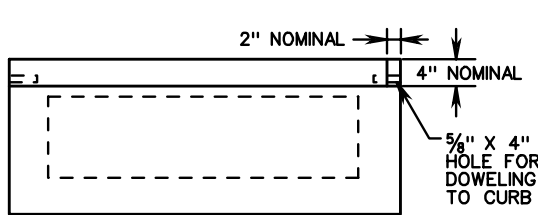

BACK VIEW

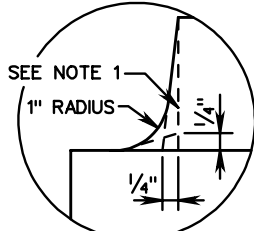

DETAIL A

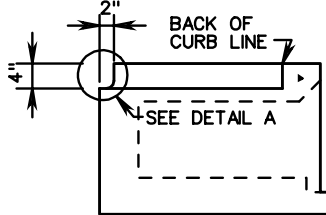

END VIEW

NOTES:

1. 2" x 4" NOTCH MAY BE FORMED WITH STRAIGHT SIDES, TAPERED SIDES OR TAPERED SIDES WITH RADIUS.
2. ALL DETAILS NOT SHOWN TO BE IN ACCORDANCE WITH SHEET 1 OF 2.

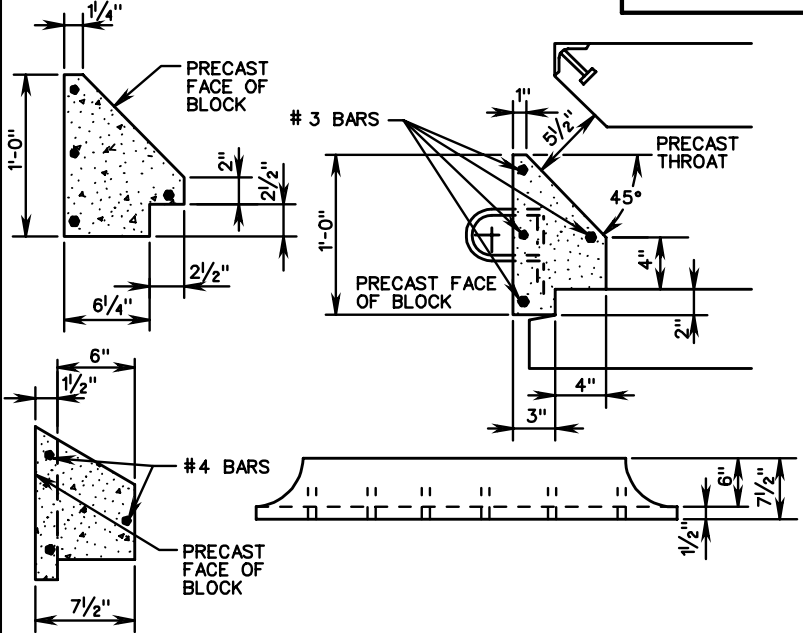

NOTE:

DOWEL HOLES PROVIDED TO PREVENT SETTLEMENT OF ADJACENT CONCRETE.

ALTERNATE DETAIL FOR FACE BLOCK (NOSE TYPE B)

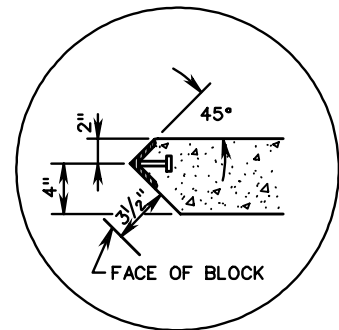

ALTERNATE NOSE DETAIL A

(FOR USE WITH MOUNTABLE CURB)

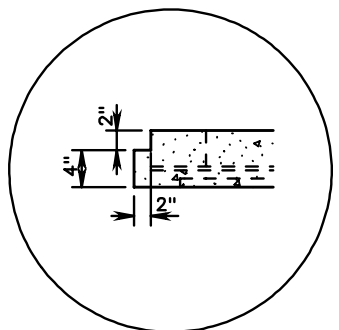

ALTERNATE DETAIL B

SPECIFICATION REFERENCE

- 105
- 233
- 302

STANDARD PRECAST TOP UNITS

VIRGINIA DEPARTMENT OF TRANSPORTATION



ROAD AND BRIDGE STANDARDS

REVISION DATE

SHEET 2 OF 2

103.06

T-DI-5

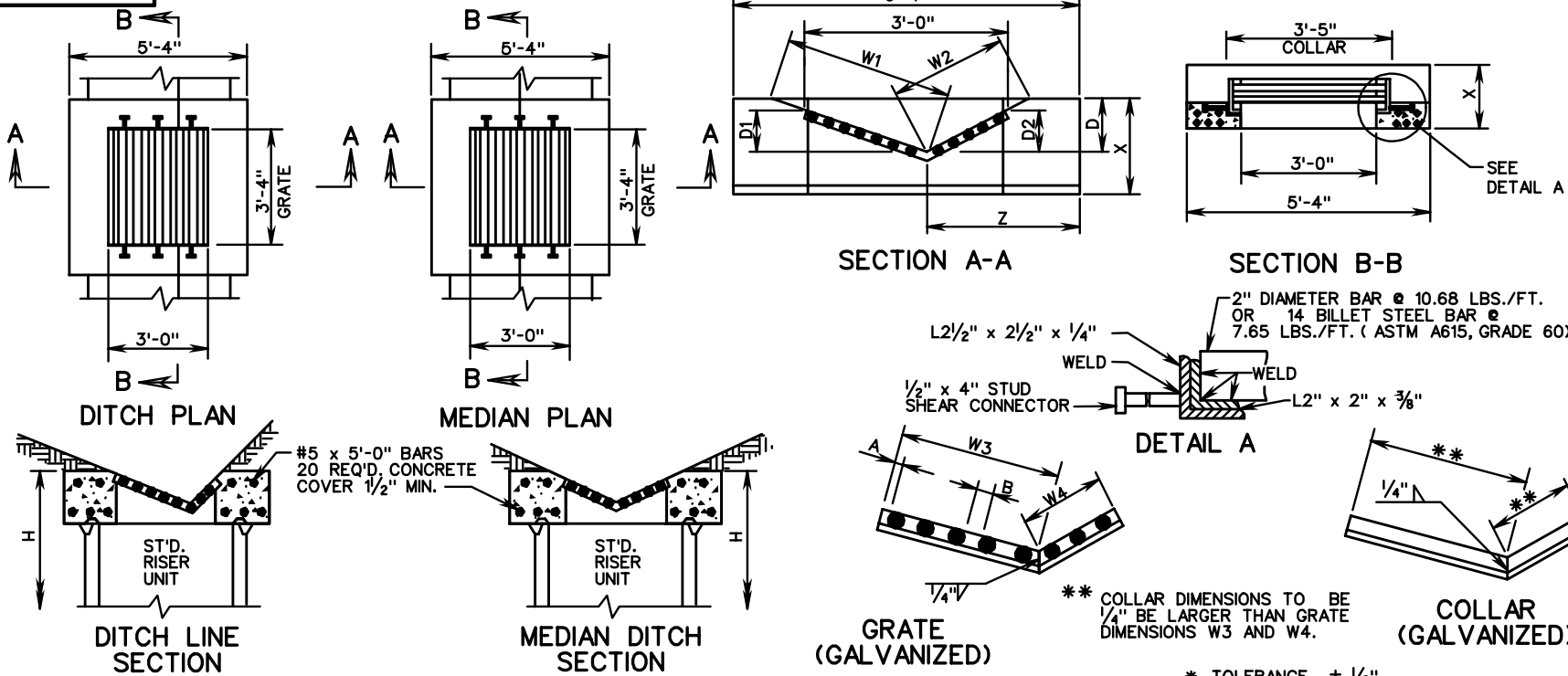

GRATE (GALVANIZED)

COLLAR (GALVANIZED)

* TOLERANCE $\pm 1/2"$

GRATE BAR SPACING CHART		
GRATE TYPE	MAXIMUM DIMENSION	
	a	b
A I	1 1/2"	3"
A III	1"	1"

ST'D PG-2 TYPE	COVER DIMENSIONS AND QUANTITIES								
	W1	W2	W3	W4	D*	D1	D2	X	Z
A1,A2,A3	3'-0 1/2"	2'-0 1/16"	2'-0 5/16"	1'-0 3/8"	6"	4"	3"	14"	2'-2"
B1,B2,B3,B4, C1,C2,C3	2'-9"	2'-9"	1'-6 7/16"	1'-6 1/16"	8"	4 1/2"	4 1/2"	16"	2'-8"
E	2'-3"	2'-3"	1'-8 1/16"	1'-8 1/16"	12"	9"	9"	19"	2'-8"

NOTES:

1. SEE GENERAL NOTES-PRECAST FOR ADDITIONAL DETAILS.
2. CONCRETE SHALL BE 4000 PSI MINIMUM.
3. REINFORCING STEEL SHALL BE IN ACCORDANCE WITH ASTM-A 615.
4. CONCRETE COVER AND GRATE ARE TO BE FURNISHED AS A SINGLE UNIT.
5. DIMENSIONS SHOWN ARE MINIMUM. ACTUAL DIMENSIONS MAY VARY WITH MANUFACTURER.
6. GRATE BARS ARE TO BE INSTALLED SO THEY WILL BE ALIGNED PARALLEL TO THE DITCH FLOW.
7. WHERE DITCH SLOPES DO NOT MATCH THOSE OF INLET COVER, THE AREA ADJACENT TO THE INLET IS TO BE GRADED TO PROVIDE A SMOOTH TRANSITION.
8. DI-5 IS TO BE UTILIZED IN LOCATIONS NOT NORMALLY SUBJECT TO TRAFFIC.

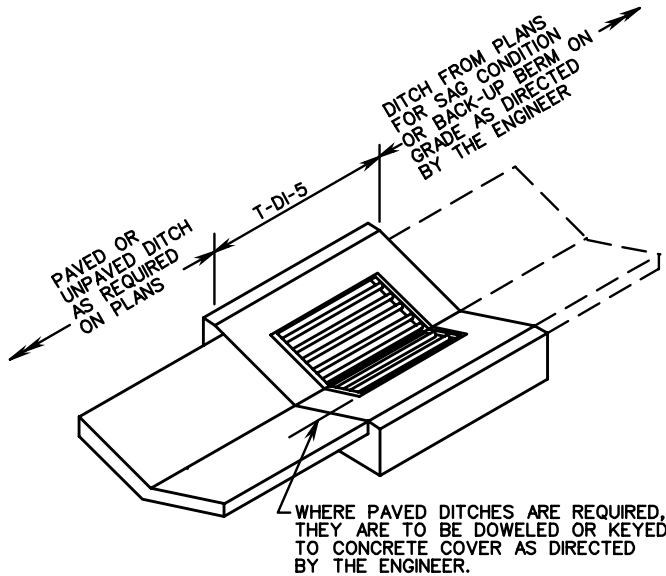

ROAD AND BRIDGE STANDARDS

SHEET 1 OF 1

REVISION DATE

103.07

STANDARD PRECAST TOP UNITS

VIRGINIA DEPARTMENT OF TRANSPORTATION

SPECIFICATION REFERENCE

105
233
302

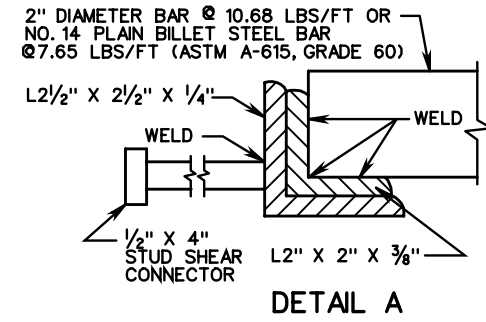
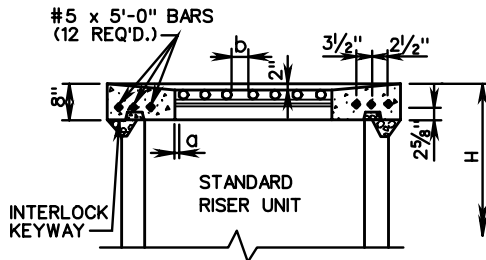
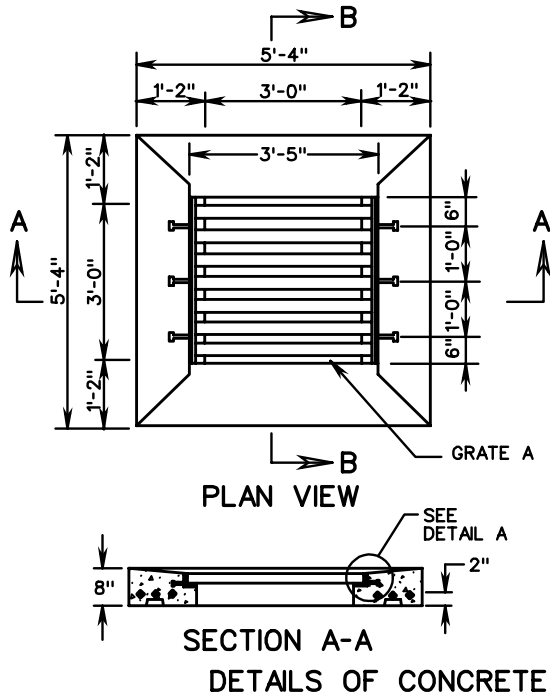

GRATE A BAR SPACING CHART		
GRATE TYPE	MAXIMUM DIMENSION	
	a	b
A I	1 1/2"	3"
A III	1"	1"

NOTES:

- SEE GENERAL NOTES-PRECAST FOR ADDITIONAL DETAILS.
- CONCRETE COVER AND GRATE ARE TO BE FURNISHED AS A SINGLE UNIT. OUTSIDE DIMENSIONS OF GRATE ARE TO BE 3'-4" X 2'-11 1/4" (GRATE A) OR 3'-4" X 2'-11 1/2" (GRATE B).
- DIMENSIONS SHOWN ARE MINIMUM. ACTUAL DIMENSIONS MAY VARY WITH MANUFACTURER.
- GRATE A IS TO BE UTILIZED IN LOCATIONS NOT NORMALLY SUBJECT TO TRAFFIC.
- GRATE B IS TO BE UTILIZED IN LOCATIONS NORMALLY SUBJECT TO TRAFFIC.
- ALTERNATE METHODS OF ANCHORING ANGLE IRON WILL BE ACCEPTABLE IF APPROVED BY THE ENGINEER.
- GRATE AND COLLAR ARE TO BE GALVANIZED AFTER FABRICATION.
- JOINTS BETWEEN CONCRETE COVER AND GUTTERS (WHEN REQUIRED) ARE TO BE DOWELED, KEYED, OR OTHER VDOT APPROVED METHODS.
- CONCRETE SHALL BE 4000 PSI MINIMUM.
- REINFORCING STEEL SHALL BE IN ACCORDANCE WITH ASTM A-615.
- GRATE BARS ARE TO BE INSTALLED SO THEY WILL BE ALIGNED PARALLEL TO THE DITCH FLOW.
- SEE STANDARD DI-7, 7A, 7B FOR DETAILS OF GUTTER, METHOD OF PLACEMENT, ALTERNATE METHODS OF CONSTRUCTION.

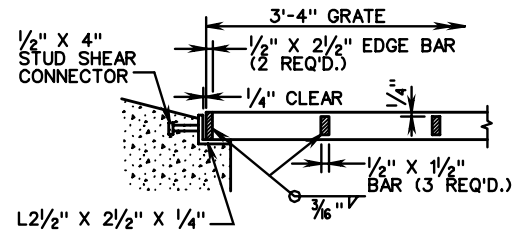
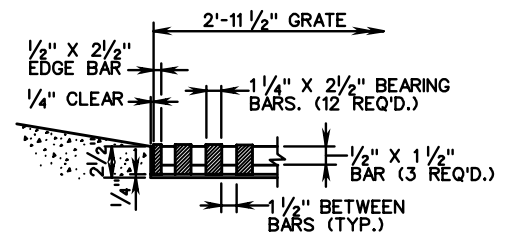
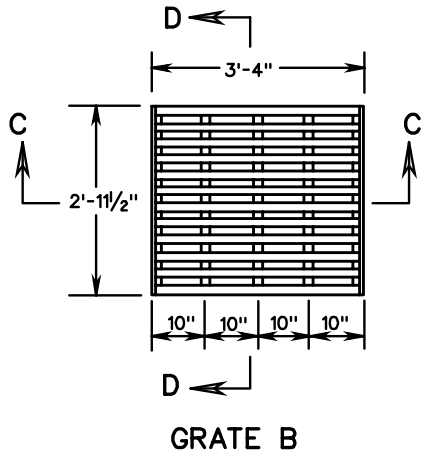

DETAILS OF LOAD CARRYING GRATE B

SPECIFICATION REFERENCE
105
233
302

STANDARD PRECAST TOP UNITS

VIRGINIA DEPARTMENT OF TRANSPORTATION

VDOT	
ROAD AND BRIDGE STANDARDS	
REVISION DATE	SHEET 1 OF 1
	103.08

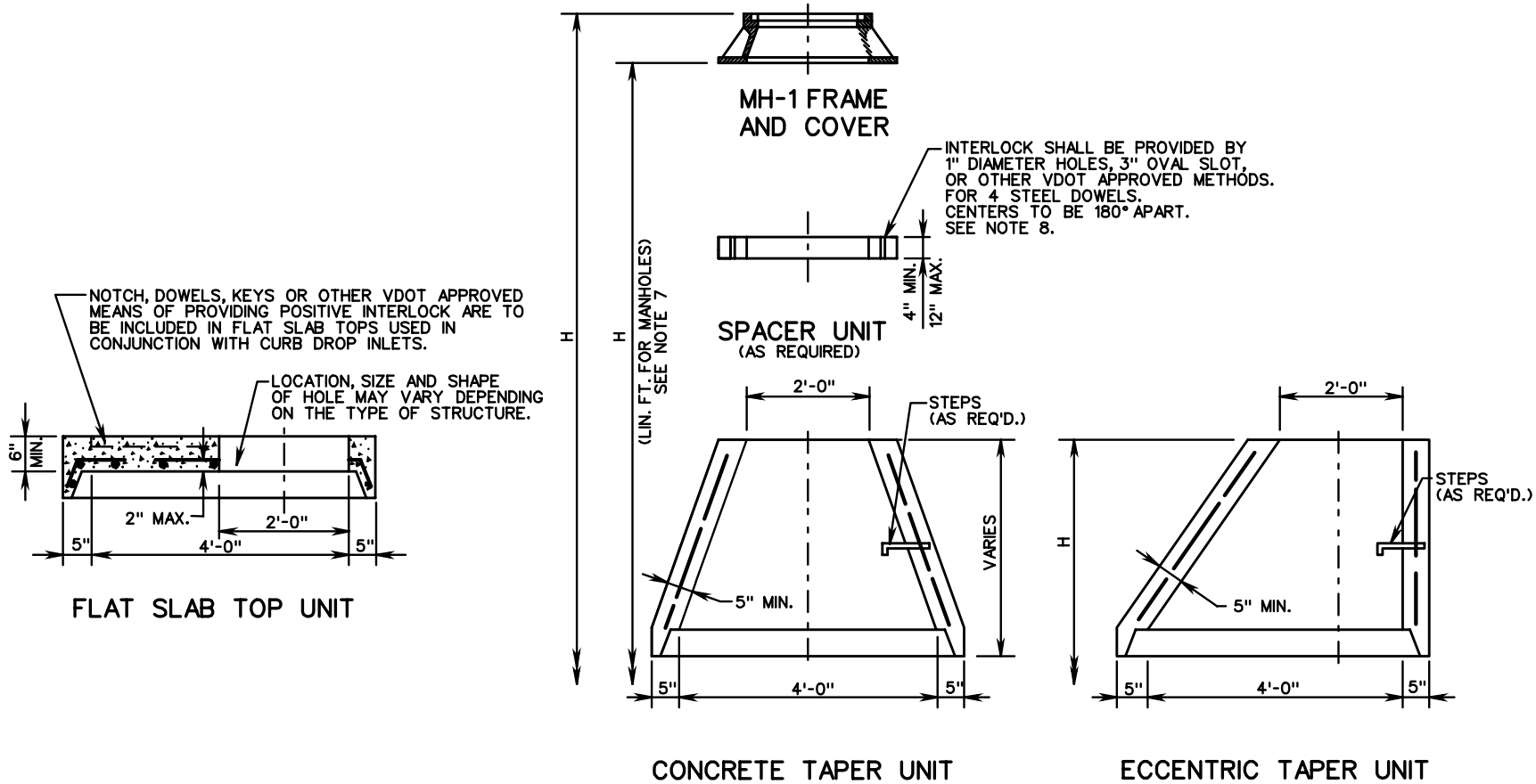

NOTES:

1. SEE GENERAL NOTES FOR ADDITIONAL INFORMATION ON WEEP HOLES, STEP REQUIREMENTS, "H" (LIN. FT. FOR MANHOLES) DIMENSION, ETC.
2. ALL SPACER UNITS, FLAT SLAB TOPS, AND TAPER UNITS ARE TO BE IN ACCORDANCE WITH THE REQUIREMENTS OF AASHTO M199.
3. CONCRETE SHALL BE 4000 PSI.
4. FOR STEP DETAILS SEE STANDARD ST-1.
5. DIMENSIONS SHOWN ARE MINIMUM. ACTUAL DIMENSIONS MAY VARY WITH MANUFACTURER.
6. SPACER UNITS SHOWN HEREON ARE ALSO KNOWN AS "GRADE RINGS" OR "ADJUSTMENT RINGS".
7. WHEN SPACER UNITS ARE REQUIRED, "H" IS TO BE MEASURED FROM THE TOP OF THE UPPERMOST SPACER.
8. SPACER UNIT IS TO BE DOWELED OR MORTARED TO TAPER UNIT OR FLAT SLAB TOP.



ROAD AND BRIDGE STANDARDS

STANDARD PRECAST MANHOLE TOP UNITS

SPECIFICATION REFERENCE

SHEET 1 OF 1

REVISION DATE

VIRGINIA DEPARTMENT OF TRANSPORTATION

103.09

105
302

DIMENSIONS	
D	MIN. X
60"	5"
72"	6"
84"	7"
96"	8"

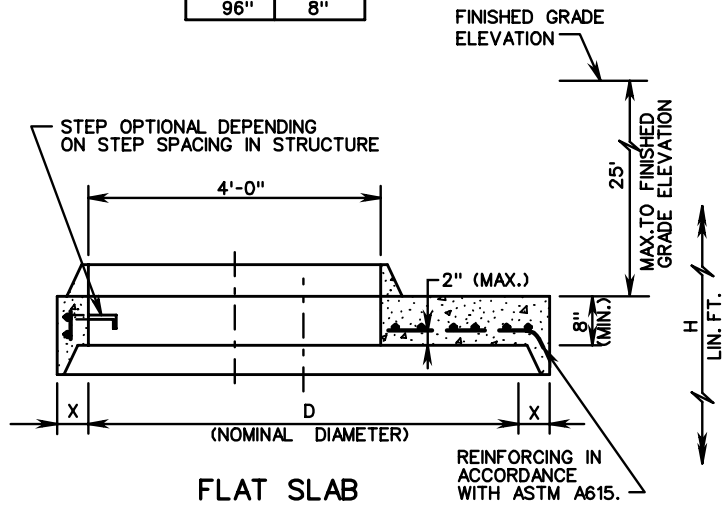

FLAT SLAB
R-2

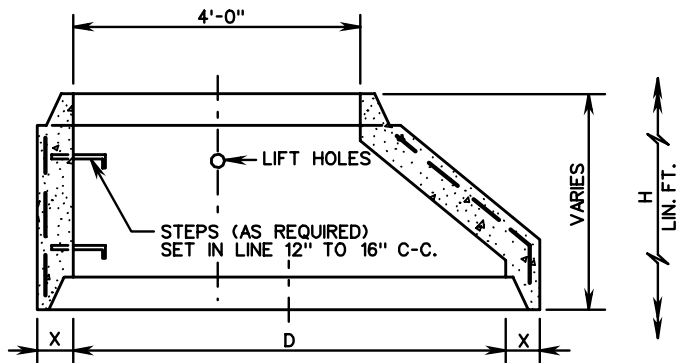

TAPER REDUCER
R-3

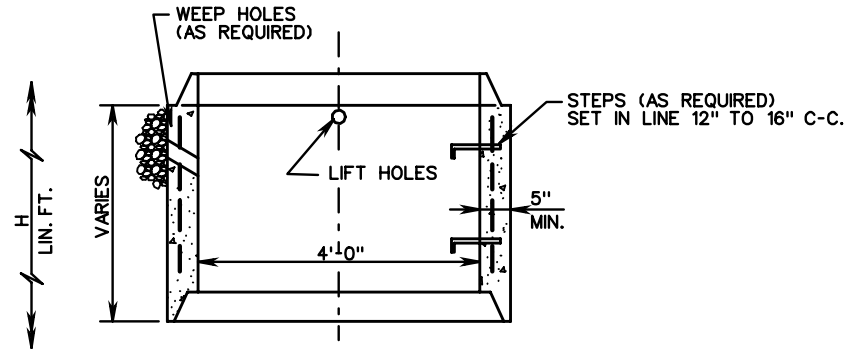

RISER
R-1

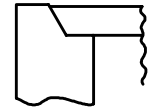

ALTERNATE JOINT DETAIL

NOTES:

1. SEE GENERAL NOTES FOR ADDITIONAL INFORMATION ON WEEP HOLES, STEP REQUIREMENTS, "H" (LIN. FT. FOR MANHOLES) DIMENSIONS, ETC.
2. ALL REDUCER AND RISER UNITS ARE TO BE IN ACCORDANCE WITH THE REQUIREMENTS OF AASHTO M199.
3. CONCRETE SHALL BE 4000 PSI.
4. WHERE OPENINGS ARE REQUIRED FOR PIPE, THEY SHALL BE FORMED, DRILLED, OR NEATLY CUT AS APPROVED BY THE ENGINEER. THE CONTRACTOR SHALL FURNISH THE FABRICATOR WITH THE ANGLES BETWEEN CENTER LINES, THE INVERT ELEVATIONS, AND THE SIZE OF ALL PIPES TO ENTER THE MANHOLE.
5. FOR STEP DETAILS SEE STANDARD ST-1.
6. DIMENSIONS SHOWN ARE MINIMUM. ACTUAL DIMENSIONS MAY VARY WITH MANUFACTURER.
7. "D" IS NOMINAL DIAMETER.
8. WHEN USING R-2 FLAT SLAB, HEIGHT OF STRUCTURE FROM THE SLAB UP TO THE FINISHED GRADE ELEVATION IS LIMITED TO A MAXIMUM OF 25'.
9. TONGUE AND GROOVE JOINT TO BE OF FABRICATOR'S DESIGN MEETING THE APPROVAL OF THE ENGINEER. JOINTS ARE TO BE SEALED WITH MORTAR, O-RING GASKETS, OR BUTYL RUBBER.

SPECIFICATION REFERENCE

105
302

STANDARD PRECAST REDUCER AND RISER UNITS

VIRGINIA DEPARTMENT OF TRANSPORTATION

VDOT

ROAD AND BRIDGE STANDARDS

REVISION DATE

SHEET 1 OF 1

103.10

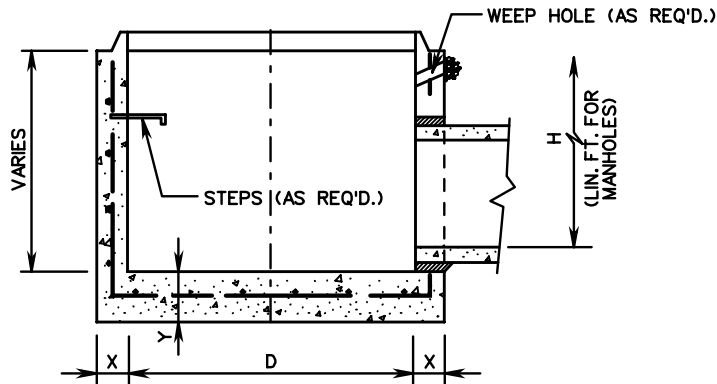

B-1
MONOLITHIC

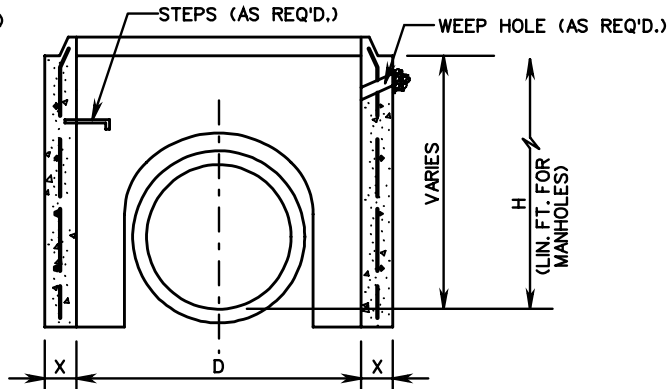

6" x 6" - W5.5 x W5.5 WELDED WIRE FABRIC OR EQUIVALENT AREA

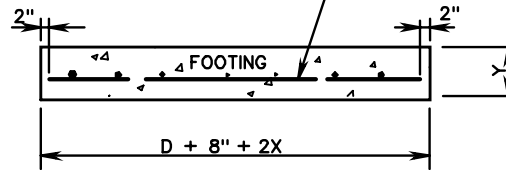

B-2
DOGHOUSE WITH FOOTING

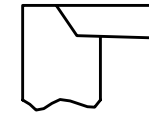

ALTERNATE JOINT
DETAIL

NOTES:

1. SEE GENERAL NOTES FOR ADDITIONAL INFORMATION ON WEEP HOLES, STEP REQUIREMENTS, "H" (LIN. FT. FOR MANHOLES) DIMENSIONS, ETC.
2. ALL BASE UNITS ARE TO BE IN ACCORDANCE WITH THE REQUIREMENTS OF AASHTO M199.
3. CONCRETE SHALL BE 4000 PSI.
4. WHERE OPENINGS ARE REQUIRED FOR PIPE, THEY SHALL BE FORMED, DRILLED, OR NEATLY CUT AS APPROVED BY THE ENGINEER. THE CONTRACTOR SHALL FURNISH THE FABRICATOR WITH THE ANGLES BETWEEN CENTER LINES, THE INVERT ELEVATIONS, AND THE SIZE OF ALL PIPES TO ENTER THE MANHOLE. HOLES ARE TO BE A MINIMUM OF 4" TO A MAXIMUM OF 8" LARGER THAN THE OUTSIDE DIAMETER OF THE PROPOSED PIPE.
5. DIMENSIONS SHOWN ARE MINIMUM. ACTUAL DIMENSIONS MAY VARY WITH MANUFACTURER.
6. "D" IS NOMINAL DIAMETER.
7. IN THE EVENT THE INVERT OF THE OUTFALL PIPE IS HIGHER THAN THE BOTTOM OF THE STRUCTURE, THE INVERT OF THE STRUCTURE SHALL BE SHAPED WITH CEMENT MORTAR TO PREVENT STANDING OR PONDING OF WATER IN THE STRUCTURE.
8. TONGUE AND GROOVE JOINT ARE TO BE OF FABRICATOR'S DESIGN MEETING VDOT APPROVAL. JOINTS ARE TO BE SEALED WITH MORTAR, O-RING GASKETS, OR BUTYL RUBBER.

DIMENSIONS				
D	X MINIMUM	Y MINIMUM	SUGGESTED MAX. PIPE SIZE	ABSOLUTE MAXIMUM ☆
* 36"	4"	6"	18"	21"
48"	5"	6"	24"	27"
60"	5"	8"	36"	42"
72"	6"	8"	48"	54"
84"	7"	8"	60"	66"
96"	8"	8"	66"	72"

* DEPTH "H" OF 36" DIAMETER BASE UNIT RESTRICTED TO 4'-0" MAXIMUM.

☆ ONE THROUGH PIPE ONLY. (ONE PIPE ENTERING AND ONE PIPE EXITING STRUCTURE)



ROAD AND BRIDGE STANDARDS

STANDARD PRECAST BASE UNITS

SPECIFICATION
REFERENCE

SHEET 1 OF 1

REVISION DATE

VIRGINIA DEPARTMENT OF TRANSPORTATION

103.11

105
302

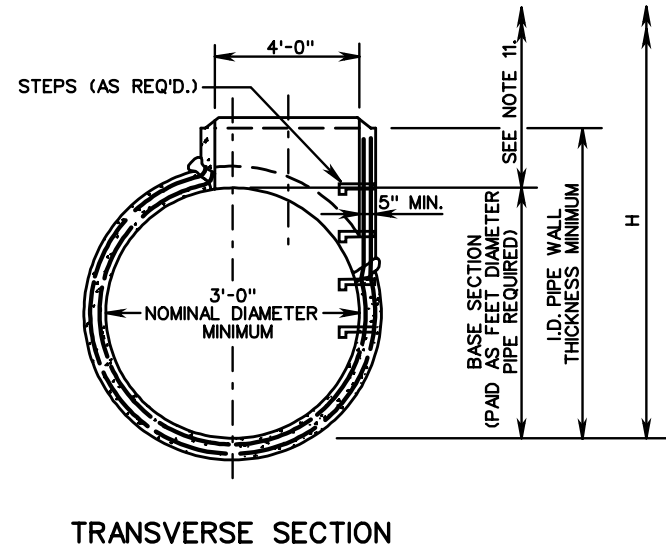
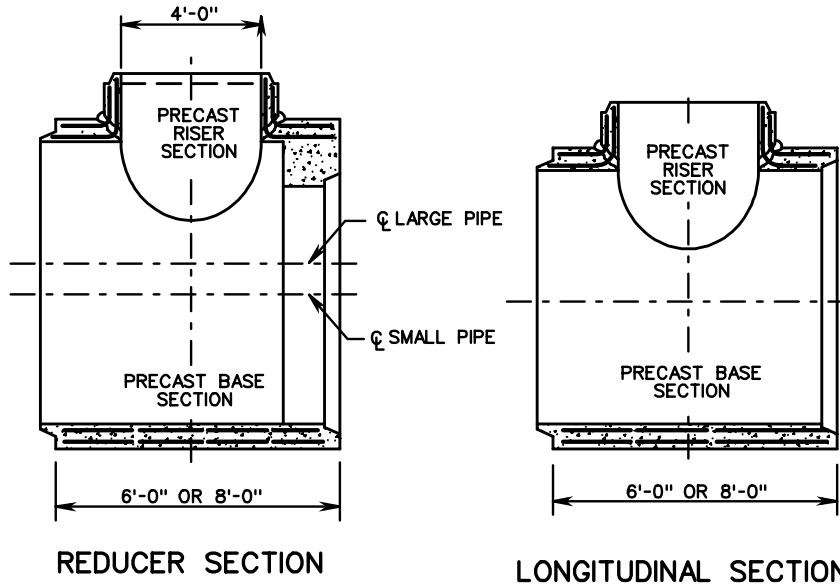

NOTES:

1. SEE GENERAL NOTES FOR ADDITIONAL INFORMATION ON WEEP HOLES, STEP REQUIREMENTS, "H" DIMENSION, ETC.
2. THE TEE UNIT IS TO BE PRECAST FOR DELIVERY TO THE CONSTRUCTION SITE AS A COMPLETE UNIT. ALTERNATE DESIGNS MEETING THE APPROVAL OF THE ENGINEER MAY BE SUBSTITUTED FOR THAT SHOWN HEREON.
3. THE PRECAST BASE SECTION IS TO CONFORM TO THE REQUIREMENTS OF AASHTO M170.
4. THE PRECAST RISER SECTION IS TO CONFORM TO THE REQUIREMENTS OF AASHTO M199, EXCEPT THAT MINIMUM WALL THICKNESS IS TO BE 5".
5. THE BASE SECTION IS TO BE THE SAME CLASS AND STRENGTH AS THE ADJOINING PIPE CULVERT AND THE TONGUE AND GROOVE JOINTS ARE TO BE OF AN IDENTICAL DESIGN.
6. CONCENTRIC RISER SECTION MAY BE SUBSTITUTED WHEN APPROVED BY THE ENGINEER.
7. OTHER MANUFACTURER'S DESIGNS FOR REDUCER SECTION MAY BE SUBSTITUTED WHEN APPROVED BY THE ENGINEER.
8. REDUCER SECTIONS WITH PIPE CROWNS OR CENTER LINES MATCHED ARE AVAILABLE IN ADDITION TO THE MATCHED INVERTS SHOWN HEREON.
9. WELD AND SPLICE LONGITUDINAL AND CIRCUMFERENTIAL STEEL OF RISER AND BASE SECTIONS TO MAINTAIN CONTINUITY OF REINFORCEMENT.
10. HAND OR PNEUMATICALLY PLACE MORTAR AND SHAPE INTO COLLAR.
11. RISER SECTION PAID AS STANDARD DROP INLET OR LIN. FT. MANHOLE DEPENDING ON USE OF STRUCTURE.

TEE SECTION

OPTIONAL VARIATIONS AVAILABLE WHEN SPECIFIED AS A MODIFIED B-3

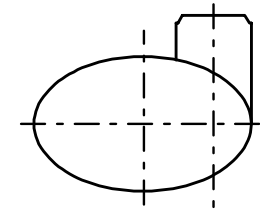

SECTION ELLIPTICAL TEE MANHOLE

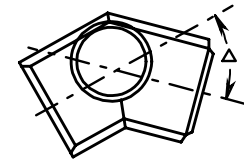

PLAN MANHOLE TEE BEND

SPECIFICATION REFERENCE
105 302

STANDARD PRECAST BASE UNITS
 MAX. DEPTH (H) 25'
 VIRGINIA DEPARTMENT OF TRANSPORTATION

VDOT ROAD AND BRIDGE STANDARDS	
REVISION DATE	SHEET 1 OF 1
	103.12

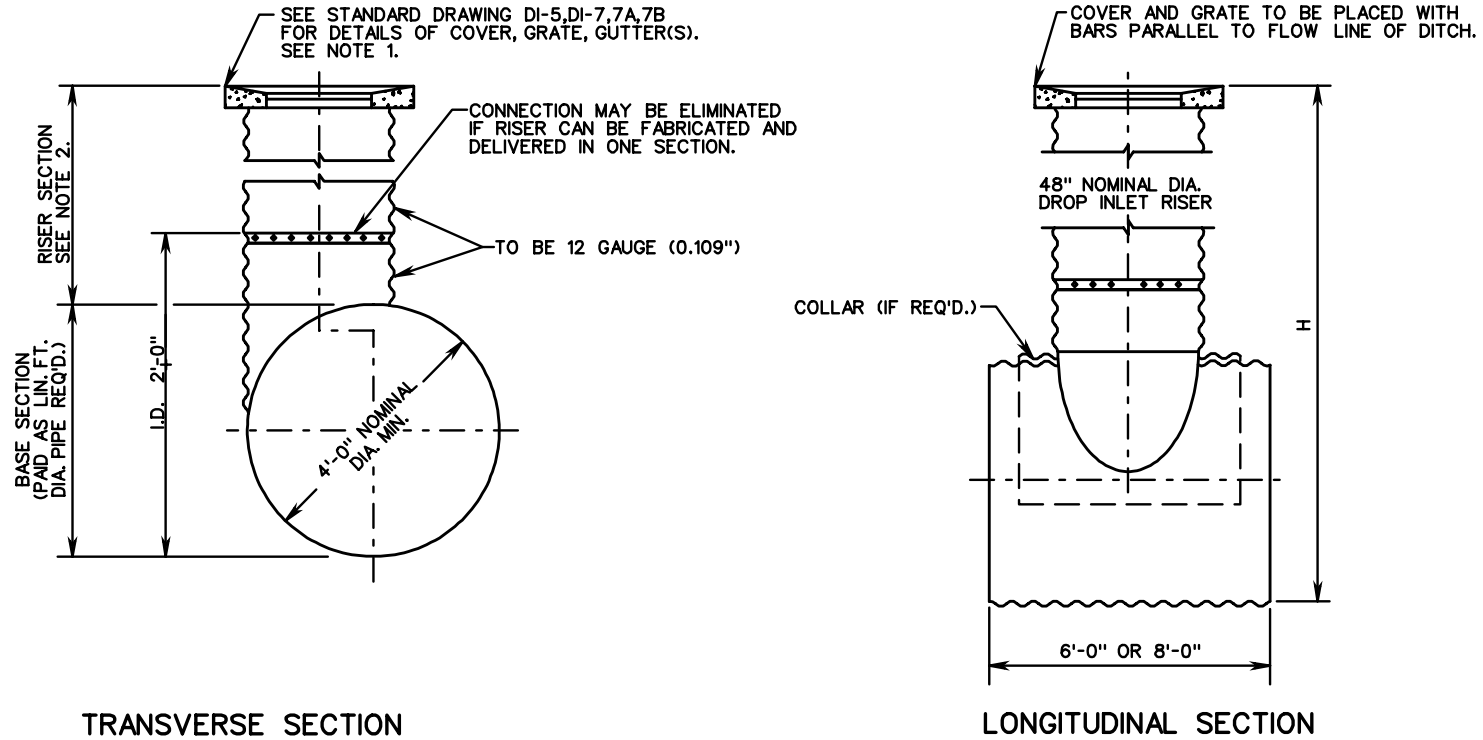

NOTES:

1. OTHER STANDARD GRATES OR DROP INLET THROAT SECTIONS MAY BE SUBSTITUTED WHEN SPECIFIED ON PLANS.
2. RISER SECTION PAID AS STANDARD DROP INLET OR LIN. FT. OF MANHOLE DEPENDING ON USE OF STRUCTURE.
3. THE TEE UNIT IS TO BE FABRICATED FOR DELIVERY TO THE CONSTRUCTION SITE AS A COMPLETE UNIT. ACTUAL DESIGN DETAILS AND METHODS OF CONSTRUCTION WILL BE AT THE OPTION OF THE FABRICATOR AND MEETING THE APPROVAL OF THE ENGINEER, EXCEPT THE SHEET THICKNESS CORRUGATION, AND SPECIFICATIONS TO BE MET WILL BE THE SAME AS THOSE REQUIRED FOR THE ADJOINING PIPE CULVERT. IF ASPHALT COATING IS SPECIFIED FOR THE CULVERT, THE TEE UNIT SHALL ALSO BE COATED.
4. WHEN REQUIRED, CONNECTION BETWEEN DROP INLET RISER AND TEE UNIT MAY BE BOLTED OR RIVETED.

VDOT ROAD AND BRIDGE STANDARDS	
SHEET 1 OF 1	REVISION DATE
103.13	

CORRUGATED METAL TEE SECTION
MAX. DEPTH (H) 25'
VIRGINIA DEPARTMENT OF TRANSPORTATION

SPECIFICATION REFERENCE
302

THIS PAGE INTENTIONALLY LEFT BLANK

SPECIFICATION
REFERENCE

VIRGINIA DEPARTMENT OF TRANSPORTATION



ROAD AND BRIDGE STANDARDS

REVISION DATE

SHEET 1 OF 1

103.14

DI-1

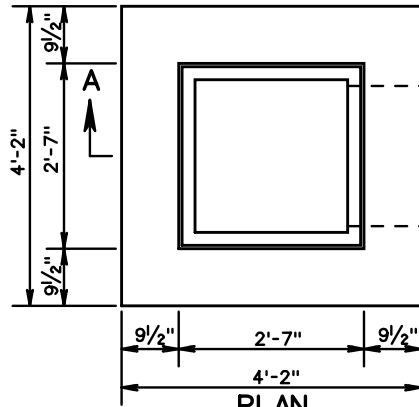

PLAN (GRATE REMOVED)

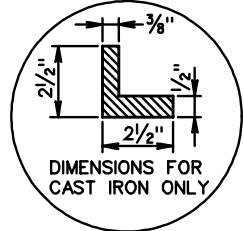

DETAIL A

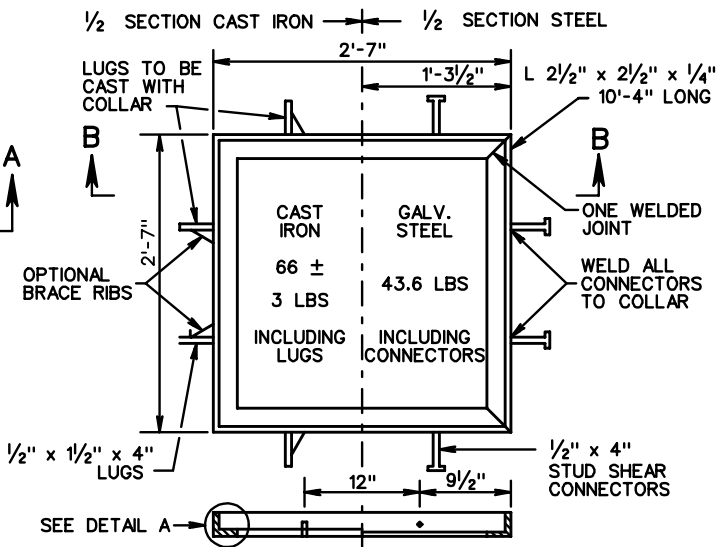

SECTION B-B COLLAR DETAIL

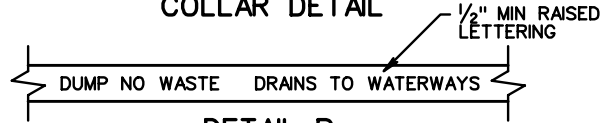

DETAIL B

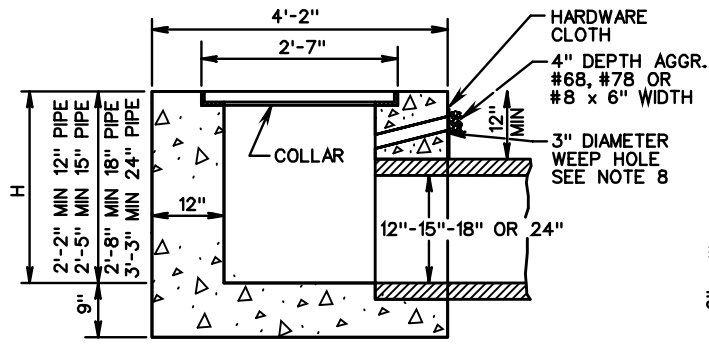

SECTION A-A

CONCRETE QUANTITIES FOR MIN. DEPTH

- 12" CONCRETE PIPE - 1.440 CU. YD. CONCRETE
- 15" CONCRETE PIPE - 1.528 CU. YD. CONCRETE
- 18" CONCRETE PIPE - 1.620 CU. YD. CONCRETE
- 24" CONCRETE PIPE - 1.817 CU. YD. CONCRETE

ADD 0.469 CU. YD. PER ADDITIONAL FOOT OF DEPTH.

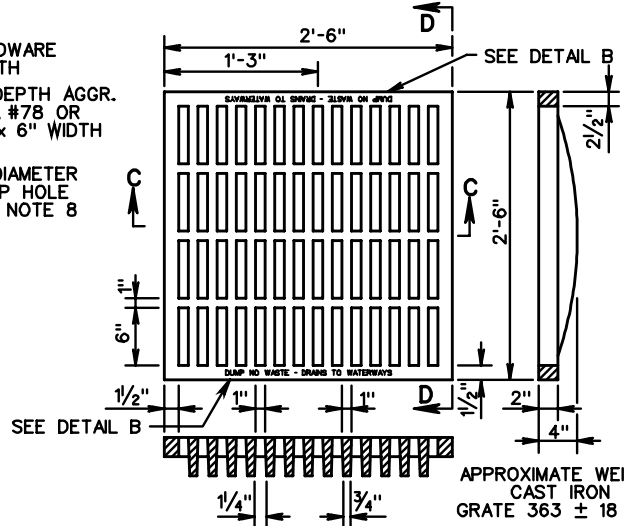

SECTION C-C SECTION D-D GRATE DETAIL

NOTES

1. DEPTH OF INLET (H) TO BE SHOWN ON PLANS. FOR DEPTH GREATER THAN 10' USE STANDARD DI-1A
2. THE "H" DIMENSION SHOWN ON THE STANDARDS AND SPECIFIED ON THE PLANS WILL BE MEASURED FROM THE INVERT OF THE OUTFALL PIPE TO THE TOP OF THE STRUCTURE. PLAN "H" DIMENSIONS ARE APPROXIMATE ONLY FOR ESTIMATING PURPOSES AND THE ACTUAL DIMENSIONS SHALL BE DETERMINED BY THE CONTRACTOR FROM FIELD CONDITIONS.
3. WHEN SPECIFIED ON THE PLANS THE INVERT IS TO BE SHAPED IN ACCORDANCE WITH STANDARD IS-1. THE COST OF FURNISHING AND PLACING ALL MATERIALS INCIDENTAL TO THE SHAPING IS TO BE INCLUDED IN THE BID PRICE FOR THE STRUCTURE.
4. IN THE EVENT THE INVERT OF THE OUTFALL PIPE IS HIGHER THAN THE BOTTOM OF THE STRUCTURE, THE INVERT OF THE STRUCTURE SHALL BE SHAPED WITH CEMENT MORTAR TO PREVENT STANDING OR PONDING OF WATER IN THE STRUCTURE. THE COST OF FURNISHING AND PLACING ALL MATERIALS INCIDENTAL TO INLET SHAPING IS TO BE INCLUDED IN THE BID PRICE FOR THE STRUCTURE.
5. STEPS ARE TO BE PROVIDED WHEN H IS 4'-0" OR GREATER. FOR DETAILS SEE STANDARD ST-1.
6. THIS ITEM MAY BE PRECAST OR CAST-IN-PLACE.
7. #4 X 8" SMOOTH DOWELS AT APPROXIMATELY 12" C-C TO BE PLACED IN ALL AREAS ADJACENT TO ABUTTING CONCRETE TO PREVENT SETTLEMENT. IN LIEU OF DOWELS A 2"X4" NOTCH MAY BE PROVIDED. SEE STANDARD T-DI-3, 4 FOR ALTERNATE DESIGN.
8. 3" DIAMETER WEEP HOLE WITH 12"X12" PLASTIC HARDWARE CLOTH 1/4" MESH OR GALVANIZED STEEL WIRE, MINIMUM WIRE DIAMETER 0.03", NUMBER 4 MESH HARDWARE CLOTH ANCHORED FIRMLY TO THE OUTSIDE OF THE STRUCTURE.
9. CAST IN PLACE CONCRETE IS TO BE CLASS A3 (3000 PSI). PRECAST CONCRETE IS TO BE 4000 PSI.
10. ANY ALTERNATE METHODS OF ANCHORAGE MEETING THE APPROVAL OF THE ENGINEER MAY BE SUBSTITUTED FOR THE CAST IRON LUGS AS SHOWN HEREON.
11. DUMP NO WASTE DRAINS TO WATERWAY LETTERING IS REQUIRED ON ALL DI-1 GRATES. LOCATION OF LETTERING MAY VARY BY MANUFACTURER.



ROAD AND BRIDGE STANDARDS

SHEET 1 OF 1

REVISION DATE

104.01

STANDARD DROP INLET

12" - 24" PIPE: MAXIMUM DEPTH (H) - 10'

VIRGINIA DEPARTMENT OF TRANSPORTATION

SPECIFICATION REFERENCE

233
302

NOTES

1. DEPTH OF INLET (H) TO BE SHOWN ON PLANS. MAXIMUM DEPTH (H) TO BE 20'. FOR DEPTHS LESS THAN 10' USE STANDARD DI-1.
2. THE "H" DIMENSION SHOWN ON THE STANDARDS AND SPECIFIED ON THE PLANS WILL BE MEASURED FROM THE INVERT OF THE OUTFALL PIPE TO THE TOP OF THE STRUCTURE. PLAN "H" DIMENSIONS ARE APPROXIMATE ONLY FOR ESTIMATING PURPOSES AND THE ACTUAL DIMENSIONS SHALL BE DETERMINED BY THE CONTRACTOR FROM FIELD CONDITIONS.
3. WHEN SPECIFIED ON THE PLANS THE INVERT IS TO BE SHAPED IN ACCORDANCE WITH STANDARD IS-1. THE COST OF FURNISHING AND PLACING ALL MATERIALS INCIDENTAL TO THE SHAPING IS TO BE INCLUDED IN THE BID PRICE FOR THE STRUCTURE.
4. IN THE EVENT THE INVERT OF THE OUTFALL PIPE IS HIGHER THAN THE BOTTOM OF THE STRUCTURE, THE INVERT OF THE STRUCTURE SHALL BE SHAPED WITH CEMENT MORTAR TO PREVENT STANDING OR PONDING OF WATER IN THE STRUCTURE. THE COST OF FURNISHING AND PLACING ALL MATERIALS INCIDENTAL TO THE SHAPING IS TO BE INCLUDED IN THE BID PRICE FOR THE STRUCTURE.
5. STEPS ARE REQUIRED. FOR DETAILS SEE ST'D. ST-1.
6. THIS ITEM MAY BE PRECAST OR CAST-IN-PLACE.
7. # 4 X 8" SMOOTH DOWELS AT APPROXIMATELY 12" C-C TO BE PLACED IN ALL AREAS ADJACENT TO ABUTTING CONCRETE TO PREVENT SETTLEMENT. IN LIEU OF DOWELS A 2" X 4" NOTCH MAY BE PROVIDED. SEE STANDARD T-DI-3, 4 FOR ALTERNATE DESIGN.
8. 3" DIAMETER WEEP HOLE WITH 12"X12" PLASTIC HARDWARE CLOTH 1/4" MESH OR GALVANIZED STEEL WIRE, MINIMUM WIRE DIAMETER 0.03", NUMBER 4 MESH HARDWARE CLOTH ANCHORED FIRMLY TO THE OUTSIDE OF THE STRUCTURE.
9. ALL REINFORCING STEEL SHALL HAVE A MIN. COVER OF 2".
10. ALL REINFORCING STEEL TO BE CUT CLEAR OF ALL OPENINGS BY 2".
11. CAST-IN PLACE CONCRETE IS TO BE CLASS A3 (3000 PSI). PRECAST CONCRETE IS TO BE 4000 PSI.
12. ALL SPLICES IN BARS V TO BE A MINIMUM OF 40 DIAMETERS (20").
13. IF OPTIONAL CONSTRUCTION JOINT IS USED, IT IS TO BE KEYS.
14. FOR DETAILS AND DIMENSIONS, ETC. OF GRATE AND STEEL OR CAST IRON COLLAR SEE STANDARD DI-1.

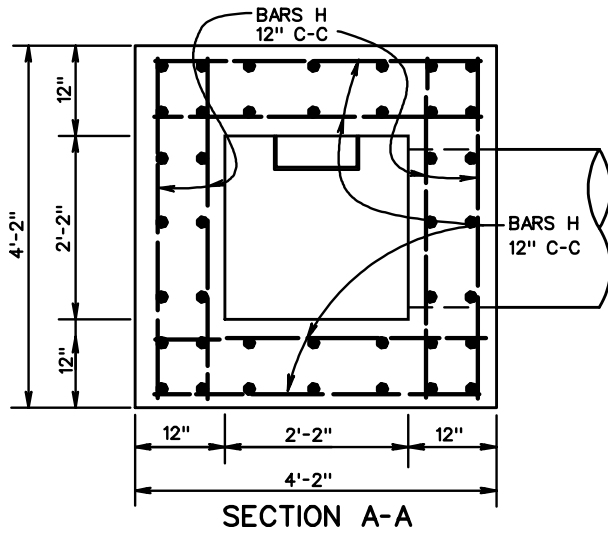

SECTION A-A

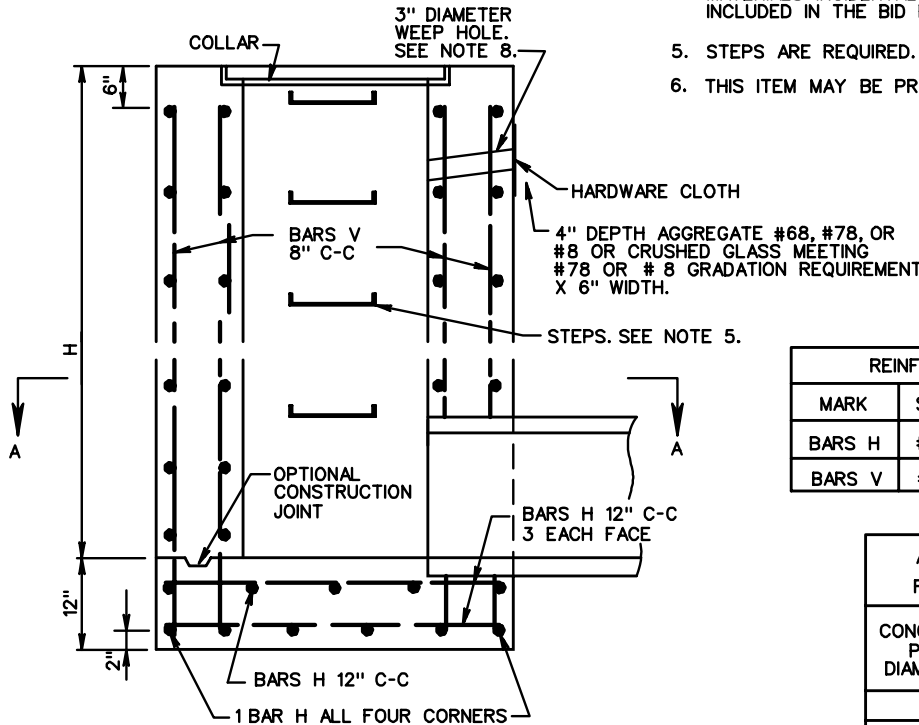

SECTION THROUGH ELEVATION

REINFORCING STEEL SCHEDULE			
MARK	SIZE	NO REQ'D	LENGTH
BARS H	#5	8x(H + 2)	3'-10"
BARS V	#4	40	H + 4"

APPROXIMATE QUANTITIES FOR MINIMUM (10') DEPTH		
CONCRETE PIPE DIAMETER	CONCRETE	REINF. STEEL
	CU. YDS.	Lbs.
12"	5.218	655
15"	5.193	651
18"	5.163	647
24"	5.089	639

INCREMENTS TO BE ADDED FOR EACH ADDITIONAL FOOT OF DEPTH (H):
 0.465 CU. YDS. OF CONCRETE
 58.7 LBS. OF REINFORCING STEEL

SPECIFICATION REFERENCE

233
302

STANDARD DROP INLET
 12" - 24" PIPE: DEPTH (H) 10' TO 20'
 VIRGINIA DEPARTMENT OF TRANSPORTATION



ROAD AND BRIDGE STANDARDS

REVISION DATE SHEET 1 OF 1

104.02

TABLE OF QUANTITIES

DI-2A, 2B, 2C

TYPE	L	REINFORCING STEEL														WEIGHT		
		CONCRETE		BARS A		BARS A-1		BARS B		BARS B-1		BARS C		BARS E			BARS F	
		Ft.	Cu. Yds.	No.	Lin. Ft.*	No.	Lin. Ft.*	No.	Lin. Ft.*	No.	Lin. Ft.*	No.	Lin. Ft.*	No.	Lin. Ft.*		No.	Lin. Ft.*
DI-2A	2'-2"	1.71	4	3'-2"	5	3'-2"	4	3'-6"	-	-	5	2'-0"	-	-	-	1'-6"	55	
	4'	1.95	4	3'-2"	5	5'-0"	4	3'-6"	3	4'-3" to 4'-6"	5	2'-0"	3	2'-0"	3	1'-6"	84	
DI-2B	6'	2.23	4	3'-2"	5	7'-0"	4	3'-6"	7	4'-3" to 4'-6"	5	2'-0"	3	4'-0"	3	1'-6"	119	
	8'	2.51	4	3'-2"	5	9'-0"	4	3'-6"	11	4'-3" to 4'-6"	5	2'-0"	3	6'-0"	3	1'-6"	154	
	10'	2.79	4	3'-2"	5	11'-0"	4	3'-6"	15	4'-3" to 4'-6"	5	2'-0"	3	8'-0"	3	1'-6"	189	
	12'	3.05	4	3'-2"	5	13'-0"	4	3'-6"	19	4'-3" to 4'-6"	5	2'-0"	3	10'-0"	3	1'-6"	224	
	14'	3.34	4	3'-2"	5	15'-0"	4	3'-6"	23	4'-3" to 4'-6"	5	2'-0"	3	12'-0"	3	1'-6"	259	
	16'	3.61	4	3'-2"	5	17'-0"	4	3'-6"	27	4'-3" to 4'-6"	5	2'-0"	3	14'-0"	3	1'-6"	294	
	18'	3.89	4	3'-2"	5	19'-0"	4	3'-6"	31	4'-3" to 4'-6"	5	2'-0"	3	16'-0"	3	1'-6"	329	
	20'	4.17	4	3'-2"	5	21'-0"	4	3'-6"	35	4'-3" to 4'-6"	5	2'-0"	3	18'-0"	3	1'-6"	364	
DI-2C	6'	2.24	4	3'-2"	5	7'-0"	4	3'-6"	6	4'-3" to 4'-6"	5	2'-0"	6	2'-1"	6	1'-6"	115	
	8'	2.55	4	3'-2"	5	9'-0"	4	3'-6"	10	4'-3" to 4'-6"	5	2'-0"	6	3'-1"	6	1'-6"	150	
	10'	2.82	4	3'-2"	5	11'-0"	4	3'-6"	14	4'-3" to 4'-6"	5	2'-0"	6	4'-1"	6	1'-6"	185	
	12'	3.09	4	3'-2"	5	13'-0"	4	3'-6"	18	4'-3" to 4'-6"	5	2'-0"	6	5'-1"	6	1'-6"	220	
	14'	3.37	4	3'-2"	5	15'-0"	4	3'-6"	22	4'-3" to 4'-6"	5	2'-0"	6	6'-1"	6	1'-6"	255	
	16'	3.65	4	3'-2"	5	17'-0"	4	3'-6"	26	4'-3" to 4'-6"	5	2'-0"	6	7'-1"	6	1'-6"	290	
	18'	3.93	4	3'-2"	5	19'-0"	4	3'-6"	30	4'-3" to 4'-6"	5	2'-0"	6	8'-1"	6	1'-6"	325	
	20'	4.20	4	3'-2"	5	21'-0"	4	3'-6"	34	4'-3" to 4'-6"	5	2'-0"	6	9'-1"	6	1'-6"	360	

NOTES

- DEPTH OF INLET (H) TO BE SHOWN ON PLANS.
- THE "H" DIMENSION SHOWN ON THE STANDARDS AND SPECIFIED ON THE PLANS WILL BE MEASURED FROM THE INVERT OF THE OUTFALL PIPE TO THE TOP OF THE STRUCTURE. PLAN "H" DIMENSIONS ARE APPROXIMATE ONLY FOR ESTIMATING PURPOSES AND THE ACTUAL DIMENSIONS SHALL BE DETERMINED BY THE CONTRACTOR FROM FIELD CONDITIONS.
- WHEN SPECIFIED ON THE PLANS THE INVERT IS TO BE SHAPED IN ACCORDANCE WITH STANDARD IS-1. THE COST OF FURNISHING AND PLACING ALL MATERIALS INCIDENTAL TO THE SHAPING IS TO BE INCLUDED IN THE BID PRICE FOR THE STRUCTURE.
- IN THE EVENT THE INVERT OF THE OUTFALL PIPE IS HIGHER THAN THE BOTTOM OF THE STRUCTURE, THE INVERT OF THE STRUCTURE SHALL BE SHAPED WITH CEMENT MORTAR TO PREVENT STANDING OR PONDING OF WATER IN THE STRUCTURE. THE COST OF FURNISHING AND PLACING ALL MATERIALS INCIDENTAL TO THE SHAPING IS TO BE INCLUDED IN THE BID PRICE FOR THE STRUCTURE.
- STEPS ARE TO BE PROVIDED WHEN H IS 4'-0" OR GREATER. FOR DETAILS SEE STANDARD ST-1.
- THIS ITEM MAY BE PRECAST OR CAST-IN-PLACE.
- # 4 X 8" SMOOTH DOWELS AT APPROXIMATELY 12" C-C TO BE PLACED IN ALL AREAS ADJACENT TO ABUTTING CONCRETE TO PREVENT SETTLEMENT.
- 3" DIAMETER WEEP HOLE TO BE LOCATED TO DRAIN SUBBASE MATERIAL. WEEP HOLE WITH 12"X12" PLASTIC HARDWARE CLOTH 1/4" MESH OR GALVANIZED STEEL WIRE, MINIMUM WIRE DIAMETER 0.03", NUMBER 4 MESH HARDWARE CLOTH ANCHORED FIRMLY TO THE OUTSIDE OF THE STRUCTURE.
- ALL REINFORCING STEEL SHALL HAVE A MINIMUM COVER OF 2".
- ALL REINFORCING STEEL TO BE CUT CLEAR OF ALL OPENINGS BY 2".
- CAST-IN PLACE CONCRETE IS TO BE CLASS A3 (3000 PSI). PRECAST CONCRETE IS TO BE 4000 PSI.
- LENGTH OF SLOT (L) WILL, IN EVERY CASE, BE SHOWN ON PLANS.
- THIS STANDARD IS INTENDED FOR USE IN CURB AND GUTTER SITUATIONS ONLY.
- STANDARD INLETS MAY BE CONSTRUCTED WITH CONCRETE BLOCKS IN ACCORDANCE WITH THE DETAILS SHOWN ON STANDARD DRAWING DI-MB.
- THIS AREA MAY BE EARTHEN, IN WHICH CASE THE EXPANSION JOINTS WILL APPLY ONLY TO CURB AND GUTTER.
- CONCRETE QUANTITIES SHOWN ARE FOR DEPTH (H) OF 5'-2" WITHOUT PIPES. THE AMOUNT DISPLACED BY PIPES MUST BE DEDUCTED TO OBTAIN TRU QUANTITIES. FOR INLETS OF DIFFERENT DEPTHS ADD OR SUBTRACT 0.28 CUBIC YARDS OF CONCRETE FOR EACH FOOT.
- LENGTH OF ANGLE IRON AS SHOWN ON SHEET 1 OF 2 IS TO BE L 16" AT 4.10 LBS./FT.
- * DENOTES LENGTH OF ONE (1) BAR.
- ALL REINFORCING BARS TO BE #5.
- GRATE TO BE INSTALLED SO SLOTS WILL DIRECT WATER TOWARD THE INLET THROAT.
- MINIMUM HEIGHT = PIPE DIA. + 2'-6" WHEN PIPES ARE LOCATED UNDER EXTENDED SLOT OF INLET.
- DUMP NO WASTE DRAINS TO WATERWAYS LETTERING IS REQUIRED ON ALL DI-2 GRATES. LOCATION OF LETTERING MAY VARY BY MANUFACTURER.

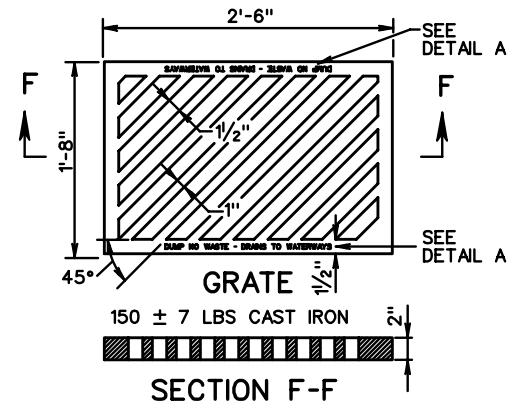
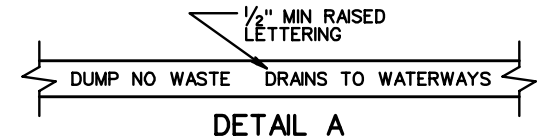

SPECIFICATION REFERENCE

233
302

STANDARD CURB DROP INLET

12" - 24" PIPE: MAXIMUM DEPTH (H)-9'

VIRGINIA DEPARTMENT OF TRANSPORTATION

VDOT

ROAD AND BRIDGE STANDARDS

REVISION DATE

SHEET 2 OF 2

104.04

NOTES

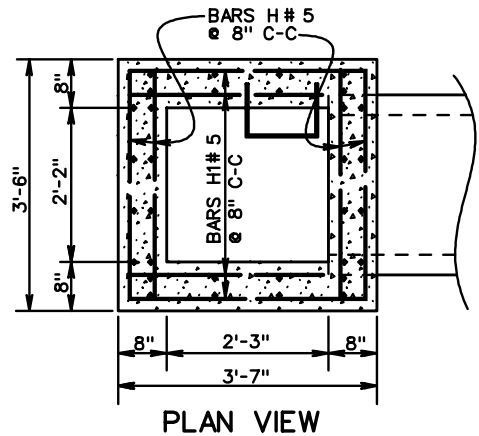

1. DEPTH OF INLET (H) TO BE SHOWN ON PLANS. MAXIMUM DEPTH (H) TO BE 20'. FOR DEPTHS LESS THAN 9' USE STANDARD DI-2A, 2B OR 2C.
2. THE "H" DIMENSION SHOWN ON THE STANDARDS AND SPECIFIED ON THE PLANS WILL BE MEASURED FROM THE INVERT OF THE OUTFALL PIPE TO THE TOP OF THE STRUCTURE. PLAN "H" DIMENSIONS ARE APPROXIMATE ONLY FOR ESTIMATING PURPOSES AND THE ACTUAL DIMENSIONS SHALL BE DETERMINED BY THE CONTRACTOR FROM FIELD CONDITIONS.
3. WHEN SPECIFIED ON THE PLANS THE INVERT IS TO BE SHAPED IN ACCORDANCE WITH STANDARD IS-1. THE COST OF FURNISHING AND PLACING ALL MATERIALS INCIDENTAL TO THE SHAPING IS TO BE INCLUDED IN THE BID PRICE FOR THE STRUCTURE.
4. IN THE EVENT THE INVERT OF THE OUTFALL PIPE IS HIGHER THAN THE BOTTOM OF THE STRUCTURE, THE INVERT OF THE STRUCTURE SHALL BE SHAPED WITH CEMENT MORTAR TO PREVENT STANDING OR PONDING OF WATER IN THE STRUCTURE. THE COST OF FURNISHING AND PLACING ALL MATERIALS INCIDENTAL TO THE SHAPING IS TO BE INCLUDED IN THE BID PRICE FOR THE STRUCTURE.
5. STEPS ARE TO BE PROVIDED. FOR DETAILS SEE STANDARD ST-1.
6. THIS ITEM MAY BE PRECAST OR CAST-IN-PLACE.
7. #4 X 8" SMOOTH DOWELS AT APPROXIMATELY 12" C-C TO BE PLACED IN ALL AREAS ADJACENT TO ABUTTING CONCRETE TO PREVENT SETTLEMENT. IN LIEU OF DOWELS A 2" X 4" NOTCH MAY BE PROVIDED. SEE STANDARD T-DI-3, 4 FOR ALTERNATE DESIGN.
8. 3" DIAMETER WEEP HOLE IS TO BE LOCATED TO DRAIN SUBBASE MATERIAL. WEEP HOLE WITH 12" X 12" PLASTIC HARDWARE CLOTH 1/4" MESH OR GALVANIZED STEEL WIRE, MINIMUM WIRE DIAMETER 0.03", NUMBER 4 MESH HARDWARE CLOTH ANCHORED FIRMLY TO THE OUTSIDE OF THE STRUCTURE.
9. ALL REINFORCING STEEL SHALL HAVE A MIN. COVER OF 2".
10. ALL REINFORCING STEEL TO BE CUT CLEAR OF ALL OPENINGS BY 2".
11. CAST-IN- PLACE CONCRETE IS TO BE CLASS A3 (3000 PSI). PRECAST CONCRETE IS TO BE 4000 PSI.
12. LENGTH OF SLOT (L) WILL, IN EVERY CASE, BE SHOWN ON PLANS.
13. THIS STANDARD IS INTENDED FOR USE IN CURB AND GUTTER SITUATIONS ONLY.
14. IF OPTIONAL CONSTRUCTION JOINT IS USED IT IS TO BE KEYS. ALL SPLICES IN BARS V TO BE A MINIMUM OF 40 DIAMETERS (20").
15. FOR PLAN VIEW OF INLET SEE STANDARD DI-2A, 2B, 2C.
16. FOR DESCRIPTION AND LOCATION OF DIMENSION L SEE SHEET 104.03.
17. FOR NUMBER OF BARS A-F REQUIRED AND LENGTHS SEE SHEET 104.04.
18. QUANTITIES SHOWN ARE FOR MINIMUM INLETS OF EACH TYPE. FOR INLETS OF GREATER DEPTHS (H) OR LONGER SLOTS (L) INCREMENTS SHOWN PER FOOT MUST BE ADDED. THE AMOUNT OF CONCRETE AND STEEL DISPLACED BY PIPES MUST BE DEDUCTED TO OBTAIN TRUE QUANTITIES.
19. FOR DETAILS AND DIMENSIONS OF CURB, SLOT, BEAM, COLLAR AND GRATE, DROPPED GUTTER LINE, AND REINFORCING AND STRUCTURAL STEEL NOT DETAILED SEE STANDARD DI-2A.

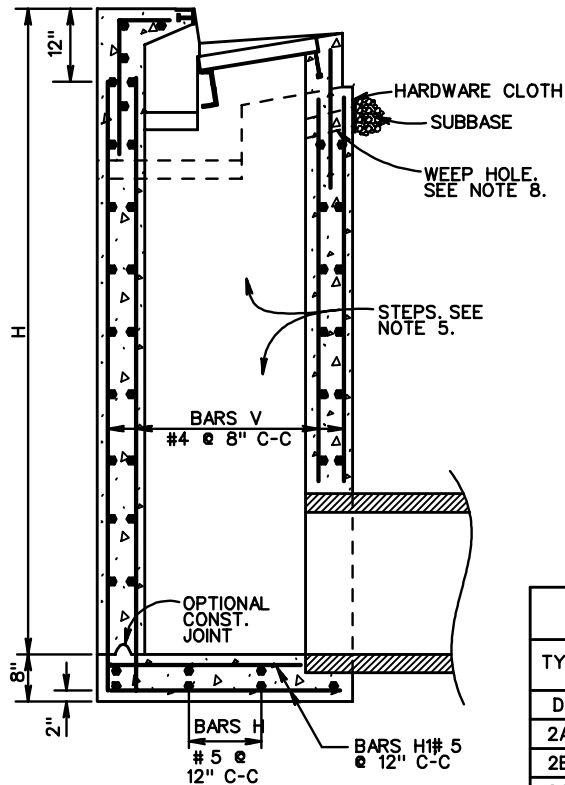

SECTION THROUGH ELEVATION

APPROXIMATE QUANTITIES FOR MINIMUM 9" DEPTH INLET			
TYPE	DIMENSION L SEE NOTE 16	REINFORCING STEEL	CONCRETE
	Lin. Ft.	Lbs.	Cu. Yds.
DI-	2'-2"	609	2.77
2AA	4'-0"	647	3.06
2CC	6'-0"	685	3.38

INCREMENTS TO BE ADDED FOR EACH ADDITIONAL FEET OF DEPTH (H) AND, OR SLOT LENGTH (L)			
H		L	
CONCRETE	STEEL	CONCRETE	STEEL
Cu. Yds.	Lbs.	Cu. Yds.	Lbs.
0.28	64	-	-
0.28	64	0.16	17
0.28	64	0.16	17

SCHEDULE OF REINFORCING STEEL SEE NOTE 17					
BARS H		BARS H1		BARS V	
NO REQ'D.	LENGTH	NO REQ'D.	LENGTH	NO REQ'D.	LENGTH
4(1.5H + 1) + 8	3'-2"	4(1.5H + 1) + 8	3'-3"	36	H - (1'-4")

VDOT
ROAD AND BRIDGE STANDARDS

SHEET 1 OF 1 REVISION DATE

104.05

STANDARD CURB DROP INLET
12" - 24" PIPE: DEPTH (H) - 9' TO 20'
VIRGINIA DEPARTMENT OF TRANSPORTATION

SPECIFICATION REFERENCE
233 302

TABLE OF QUANTITIES

TYPE	L	CONCRETE		REINFORCING STEEL														WEIGHT						
				BARS A		BARS A-1		BARS B		BARS B-1		BARS D		BARS D-1		BARS E			BARS F		BARS L		BARS M	
		Ft.	Cu. Yds.	No.	Lin. Ft.*	No.	Lin. Ft.*	No.	Lin. Ft.*	No.	Lin. Ft. *	No.	Lin. Ft. *	No.	Lin. Ft.*	No.	Lin. Ft.*		No.	Lin. Ft.*	No.	Lin. Ft.*	No.	Lin. Ft.*
DI-2D	4'-8"	4.52	1	5'-8"	5	5'-8"	7	3'-2"	-	-	13	6'-8"	13	5'-8"	-	-	-	-	12	5'-8"	13	1'-0"	328	
DI-2E	6'-0"	4.73	1	5'-8"	5	7'-0"	7	3'-2"	3	4'-3" to 4'-6"	13	6'-8"	13	5'-8"	3	1'-0"	3	1'-6"	12	5'-8"	13	1'-0"	350	
	8'-0"	5.05	1	5'-8"	5	9'-0"	7	3'-2"	7	4'-3" to 4'-6"	13	6'-8"	13	5'-8"	3	3'-0"	3	1'-6"	12	5'-8"	13	1'-0"	371	
	10'-0"	5.36	1	5'-8"	5	11'-0"	7	3'-2"	10	4'-3" to 4'-6"	13	6'-8"	13	5'-8"	3	5'-0"	3	1'-6"	12	5'-8"	13	1'-0"	406	
	12'-0"	5.68	1	5'-8"	5	13'-0"	7	3'-2"	15	4'-3" to 4'-6"	13	6'-8"	13	5'-8"	3	7'-0"	3	1'-6"	12	5'-8"	13	1'-0"	441	
	14'-0"	6.00	1	5'-8"	5	15'-0"	7	3'-2"	19	4'-3" to 4'-6"	13	6'-8"	13	5'-8"	3	9'-0"	3	1'-6"	12	5'-8"	13	1'-0"	476	
	16'-0"	6.31	1	5'-8"	5	17'-0"	7	3'-2"	23	4'-3" to 4'-6"	13	6'-8"	13	5'-8"	3	11'-0"	3	1'-6"	12	5'-8"	13	1'-0"	511	
	18'-0"	6.62	1	5'-8"	5	19'-0"	7	3'-2"	27	4'-3" to 4'-6"	13	6'-8"	13	5'-8"	3	13'-0"	3	1'-6"	12	5'-8"	13	1'-0"	546	
	20'-0"	6.94	1	5'-8"	5	21'-0"	7	3'-2"	31	4'-3" to 4'-6"	13	6'-8"	13	5'-8"	3	15'-0"	3	1'-6"	12	5'-8"	13	1'-0"	581	
	DI-2F	6'-0"	4.73	1	5'-8"	5	7'-0"	7	3'-2"	2	4'-3" to 4'-6"	13	6'-8"	13	5'-8"	6	1'-0"	6	1'-6"	12	5'-8"	13	1'-0"	353
		8'-0"	5.05	1	5'-8"	5	9'-0"	7	3'-2"	6	4'-3" to 4'-6"	13	6'-8"	13	5'-8"	6	2'-0"	6	1'-6"	12	5'-8"	13	1'-0"	388
10'-0"		5.36	1	5'-8"	5	11'-0"	7	3'-2"	10	4'-3" to 4'-6"	13	6'-8"	13	5'-8"	6	3'-0"	6	1'-6"	12	5'-8"	13	1'-0"	423	
12'-0"		5.68	1	5'-8"	5	13'-0"	7	3'-2"	14	4'-3" to 4'-6"	13	6'-8"	13	5'-8"	6	4'-0"	6	1'-6"	12	5'-8"	13	1'-0"	458	
14'-0"		6.00	1	5'-8"	5	15'-0"	7	3'-2"	18	4'-3" to 4'-6"	13	6'-8"	13	5'-8"	6	5'-0"	6	1'-6"	12	5'-8"	13	1'-0"	493	
16'-0"		6.31	1	5'-8"	5	17'-0"	7	3'-2"	22	4'-3" to 4'-6"	13	6'-8"	13	5'-8"	6	6'-0"	6	1'-6"	12	5'-8"	13	1'-0"	528	
18'-0"		6.62	1	5'-8"	5	19'-0"	7	3'-2"	26	4'-3" to 4'-6"	13	6'-8"	13	5'-8"	6	7'-0"	6	1'-6"	12	5'-8"	13	1'-0"	563	
20'-0"		6.94	1	5'-8"	5	21'-0"	7	3'-2"	30	4'-3" to 4'-6"	13	6'-8"	13	5'-8"	6	8'-0"	6	1'-6"	12	5'-8"	13	1'-0"	598	

NOTES

- DEPTH OF INLET (H) TO BE SHOWN ON PLANS.
- THE "H" DIMENSION SHOWN ON THE STANDARDS AND SPECIFIED ON THE PLANS WILL BE MEASURED FROM THE INVERT OF THE OUTFALL PIPE TO THE TOP OF THE STRUCTURE. PLAN "H" DIMENSIONS ARE APPROXIMATE ONLY FOR ESTIMATING PURPOSES AND THE ACTUAL DIMENSIONS SHALL BE DETERMINED BY THE CONTRACTOR FROM FIELD CONDITIONS.
- WHEN SPECIFIED ON THE PLANS THE INVERT IS TO BE SHAPED IN ACCORDANCE WITH STANDARD IS-1. THE COST OF FURNISHING AND PLACING ALL MATERIALS INCIDENTAL TO THE SHAPING IS TO BE INCLUDED IN THE BID PRICE FOR THE STRUCTURE.
- IN THE EVENT THE INVERT OF THE OUTFALL PIPE IS HIGHER THAN THE BOTTOM OF THE STRUCTURE, THE INVERT OF THE STRUCTURE SHALL BE SHAPED WITH CEMENT MORTAR TO PREVENT STANDING OR PONDING OF WATER IN THE STRUCTURE. THE COST OF FURNISHING AND PLACING ALL MATERIALS INCIDENTAL TO THE SHAPING IS TO BE INCLUDED IN THE BID PRICE FOR THE STRUCTURE.
- STEPS ARE TO BE PROVIDED WHEN H IS 4'-0" OR GREATER. FOR DETAILS SEE STANDARD ST-1.
- THIS ITEM MAY BE PRECAST OR CAST-IN-PLACE.
- #4 X 8" SMOOTH DOWELS AT APPROXIMATELY 12" C-C TO BE PLACED IN ALL AREAS ADJACENT TO ABUTTING CONCRETE TO PREVENT SETTLEMENT. IN LIEU OF DOWELS A 2" X 4" NOTCH MAY BE PROVIDED. SEE STANDARD T-DI-3, 4 FOR ALTERNATE DESIGN.
- 3" DIAMETER WEEP HOLE TO BE LOCATED TO DRAIN SUBBASE MATERIAL. WEEP HOLE WITH 12"X12" PLASTIC HARDWARE CLOTH 1/4" MESH OR GALVANIZED STEEL WIRE, MINIMUM WIRE DIAMETER 0.03", NUMBER 4 MESH HARDWARE CLOTH ANCHORED FIRMLY TO THE OUTSIDE OF THE STRUCTURE.
- ALL REINFORCING STEEL SHALL HAVE A MIN. COVER OF 2".
- ALL REINFORCING STEEL TO BE CUT CLEAR OF ALL OPENINGS BY 2".
- CAST-IN PLACE CONCRETE IS TO BE CLASS A3 (3000 PSI). PRECAST CONCRETE IS TO BE 4000 PSI.
- LENGTH OF SLOT (L) WILL, IN EVERY CASE, BE SHOWN ON PLANS.
- THIS STANDARD IS INTENDED FOR USE IN CURB AND GUTTER SITUATIONS ONLY.
- STANDARD INLETS MAY BE CONSTRUCTED WITH CONCRETE BLOCKS IN ACCORDANCE WITH THE DETAILS SHOWN ON STANDARD DRAWING DI-MB.
- THIS AREA MAY BE EARTHEN, IN WHICH CASE THE EXPANSION JOINTS WILL APPLY ONLY TO CURB AND GUTTER.
- CONCRETE QUANTITIES SHOWN ARE FOR DEPTH (H) OF 5'-0" WITHOUT PIPES. THE AMOUNT DISPLACED BY PIPES MUST BE DEDUCTED TO OBTAIN TRUE QUANTITIES. FOR INLETS OF DIFFERENT DEPTHS ADD OR SUBTRACT 0.63 CUBIC YARDS OF CONCRETE FOR EACH FOOT OF DEPTH.
- LENGTH OF ANGLE IRON AS SHOWN ON SHEET 1 OF 2 IS TO BE L + 16" AT 4.10 LBS./FT..
- *DENOTES LENGTH OF ONE (1) BAR.
- ALL REINFORCING BARS TO BE #5.
- GRATE TO BE INSTALLED SO SLOTS WILL DIRECT WATER TOWARD THE INLET THROAT. GRATE MUST BE REVERSIBLE (RIGHT HAND GRATE IS SHOWN).
- MINIMUM HEIGHT WHEN PIPES ARE LOCATED UNDER EXTENDED SLOT OF INLET.
- INLET MAY BE USED WITH LARGER LONGITUDINAL PIPES (72" MAXIMUM) PROVIDED HORIZONTAL CLEARANCE BETWEEN ADJACENT PIPES IS ADEQUATE AND MINIMUM HEIGHT (H) EQUALS PIPE DIAMETER PLUS 2'-10".



ROAD AND BRIDGE STANDARDS

SHEET 2 OF 2

REVISION DATE

104.07

STANDARD CURB DROP INLET

30" - 48" PIPE: MAXIMUM DEPTH (H) - 9'

VIRGINIA DEPARTMENT OF TRANSPORTATION

SPECIFICATION
REFERENCE233
302

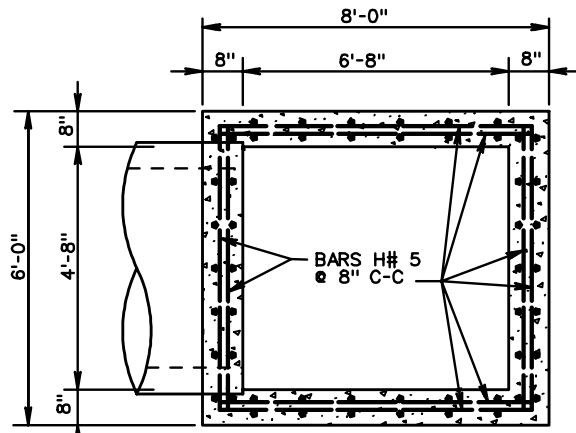

SECTION A-A

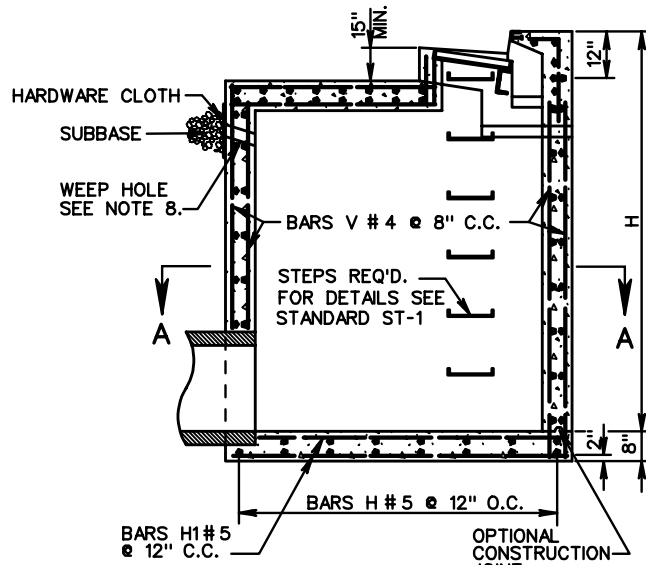

SECTION THROUGH ELEVATION

SCHEDULE OF REINFORCING STEEL		
BARS MARK	NO. REQUIRED	LENGTH
H	4(1.5H+1)+16	5'-8"
H1	4(1.5H+1)+12	7'-8"
V	76	H-1'-2"

- NOTES**
- DEPTH OF INLET (H) TO BE SHOWN ON PLANS.
 - THE "H" DIMENSION SHOWN ON THE STANDARDS AND SPECIFIED ON THE PLANS WILL BE MEASURED FROM THE INVERT OF THE OUTFALL PIPE TO THE TOP OF THE STRUCTURE. PLAN "H" DIMENSIONS ARE APPROXIMATE ONLY FOR ESTIMATING PURPOSES AND THE ACTUAL DIMENSIONS SHALL BE DETERMINED BY THE CONTRACTOR FROM FIELD CONDITIONS.
 - WHEN SPECIFIED ON THE PLANS THE INVERT IS TO BE SHAPED IN ACCORDANCE WITH STANDARD IS-1. THE COST OF FURNISHING AND PLACING ALL MATERIALS INCIDENTAL TO THE SHAPING IS TO BE INCLUDED IN THE BID PRICE FOR THE STRUCTURE.
 - IN THE EVENT THE INVERT OF THE OUTFALL PIPE IS HIGHER THAN THE BOTTOM OF THE STRUCTURE, THE INVERT OF THE STRUCTURE SHALL BE SHAPED WITH CEMENT MORTAR TO PREVENT STANDING OR PONDING OF WATER IN THE STRUCTURE. THE COST OF FURNISHING AND PLACING ALL MATERIALS INCIDENTAL TO THE SHAPING IS TO BE INCLUDED IN THE BID PRICE FOR THE STRUCTURE.
 - STEPS ARE TO BE PROVIDED WHEN H IS 4'-0" OR GREATER. FOR DETAILS SEE STANDARD ST-1.
 - THIS ITEM MAY BE PRECAST OR CAST-IN-PLACE.
 - # 4 X 8" SMOOTH DOWELS AT APPROXIMATELY 12" C-C TO BE PLACED IN ALL AREAS ADJACENT TO ABUTTING CONCRETE TO PREVENT SETTLEMENT. IN LIEU OF DOWELS A 2" X 4" NOTCH MAY BE PROVIDED. SEE STANDARD T-DI-3, 4 FOR ALTERNATE DESIGN.
 - 3" DIAMETER WEEP HOLE TO BE LOCATED TO DRAIN SUBBASE MATERIAL. WEEP HOLE WITH 12"X12" PLASTIC HARDWARE CLOTH 1/4" MESH OR GALVANIZED STEEL WIRE, MINIMUM WIRE DIAMETER 0.03", NUMBER 4 MESH HARDWARE CLOTH ANCHORED FIRMLY TO THE OUTSIDE OF THE STRUCTURE.
 - ALL REINFORCING STEEL SHALL HAVE A MIN. COVER OF 2".
 - ALL REINFORCING STEEL TO BE CUT CLEAR OF ALL OPENINGS BY 2".
 - CAST-IN PLACE CONCRETE IS TO BE CLASS A3 (3000 PSI). PRECAST CONCRETE IS TO BE 4000 PSI.
 - LENGTH OF SLOT (L) WILL, IN EVERY CASE, BE SHOWN ON PLANS.
 - THIS STANDARD IS INTENDED FOR USE IN CURB AND GUTTER SITUATIONS ONLY.
 - IF OPTIONAL CONSTRUCTION JOINT IS USED IT IS TO BE KEYS. ALL SPLICES IN BARS V TO BE A MINIMUM OF 40D (20").
 - FOR PLAN VIEW OF INLET SEE STANDARD DI-2D, 2E, 2F.
 - PROVIDE SAFETY SLABS WHEN SPECIFIED ON THE PLANS.
 - FOR DESCRIPTION AND LOCATION OF DIMENSION L SEE SHEET 104.06.
 - FOR NUMBER OF BARS A-M REQUIRED AND LENGTHS SEE SHEET 104.07.
 - QUANTITIES SHOWN ARE FOR MIN. INLETS OF EACH TYPE. FOR INLETS OF GREATER DEPTH (H) OR LARGER SLOTS (L), INCREMENTS SHOWN PER FOOT MUST BE ADDED. THE AMOUNT OF CONCRETE AND STEEL DISPLACED MUST BE DEDUCTED TO OBTAIN TRUE QUANTITIES.
 - FOR DETAILS AND DIMENSIONS OF CURB, SLOT, BEAM, COLLAR AND GRATE, DROPPED GUTTER LINE, AND REINFORCING AND STRUCTURAL STEEL NOT DETAILED SEE STANDARD DI-2D.
 - INLET MAY BE USED WITH LARGER LONGITUDINAL PIPE (72" MAXIMUM) PROVIDED HORIZONTAL CLEARANCE BETWEEN ADJACENT PIPES IS ADEQUATE.

APPROXIMATE QUANTITIES FOR MINIMUM 9' DEPTH INLET			
DI-TYPE	DIMENSION L SEE NOTE 17 Lin. Ft.	REINFORCING STEEL Lbs.	CONCRETE Cu. Yds.
2DD	4'-8"	1,683	6.93
2EE	6'-0"	1,714	7.20
2FF	6'-0"	1,733	7.25

INCREMENTS TO BE ADDED FOR EACH ADDITIONAL FOOT OF DEPTH (H) AND OR SLOT LENGTH (L)				
DI-TYPE	H		L	
	CONCRETE	STEEL	CONCRETE	STEEL
	Cu. Yds.	Lbs.	Cu. Yds.	Lbs.
2DD	0.63	191	—	—
2EE	0.63	191	0.16	17
2FF	0.63	191	0.16	17

SPECIFICATION REFERENCE
233
302

STANDARD CURB DROP INLET
30" - 48" PIPE: DEPTH (H) = 9' TO 20'
VIRGINIA DEPARTMENT OF TRANSPORTATION

VDOT ROAD AND BRIDGE STANDARDS	
REVISION DATE	SHEET 1 OF 1
104.08	

DI-3A, 3B, 3C

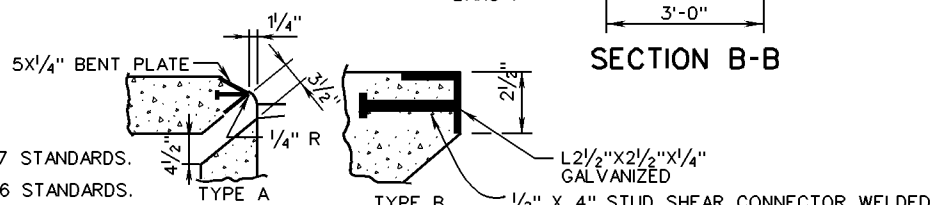
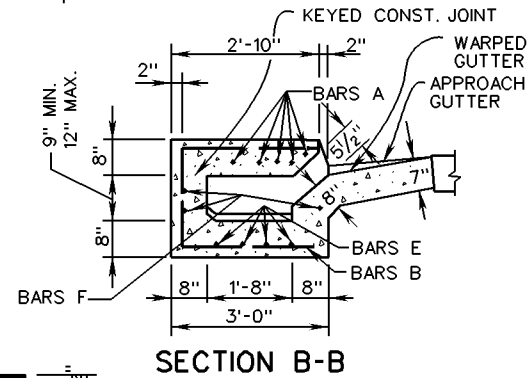
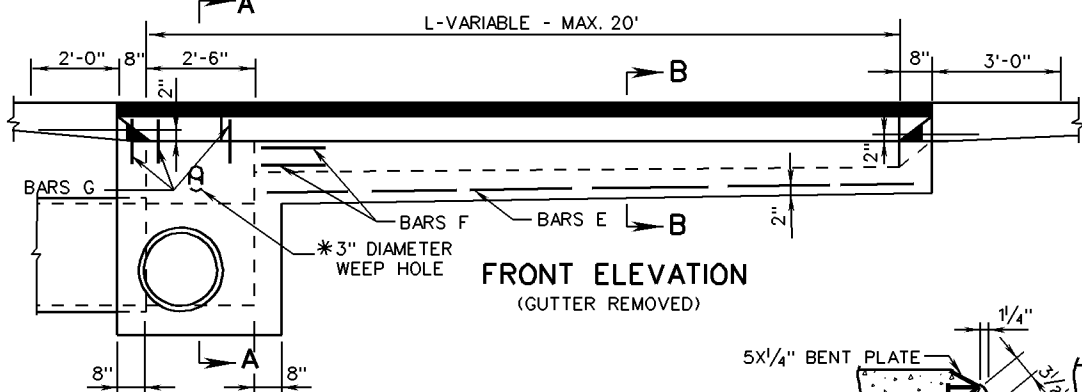
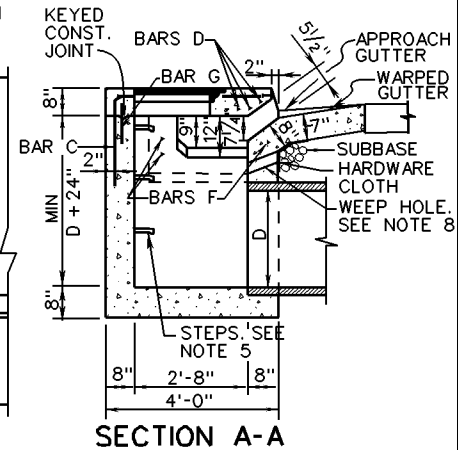
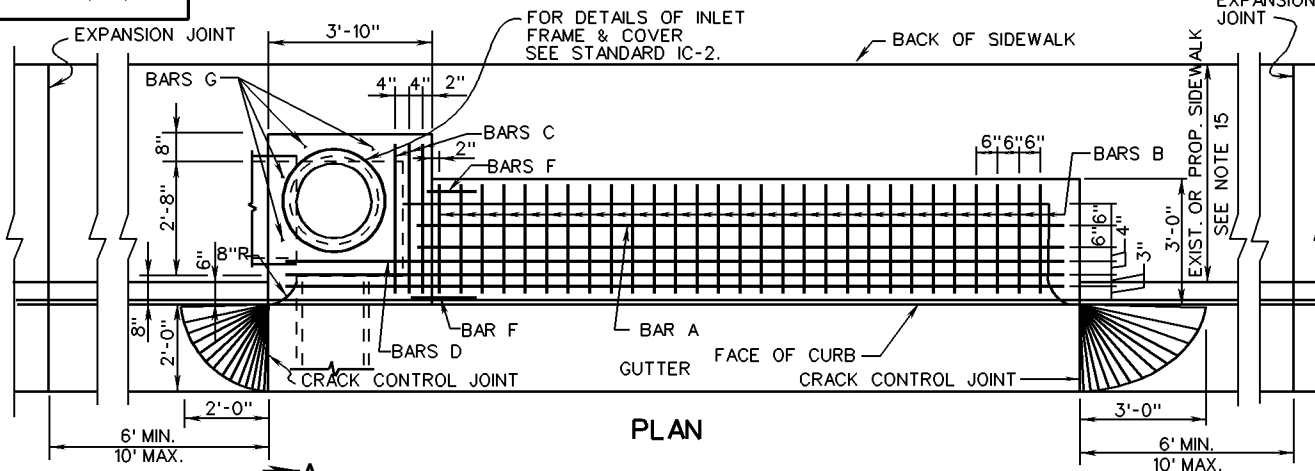

TYPE A NOSE DETAIL SHALL BE USED WITH CG-3 & CG-7 STANDARDS.
 TYPE B NOSE DETAIL SHALL BE USED WITH CG-2 & CG-6 STANDARDS.
 GALVANIZED PLATE FOR TYPE A TO BE BENT ON AN ANGLE OF 68° 30' CONNECTORS AND IS TO BE ANCHORED WITH 1/2" X 4" STUD SHEAR WELDED TO BENT PLATE AT 2' C-C.

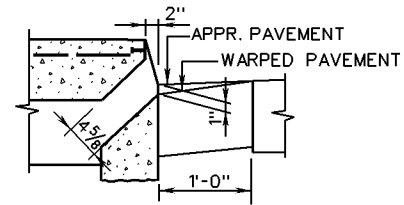
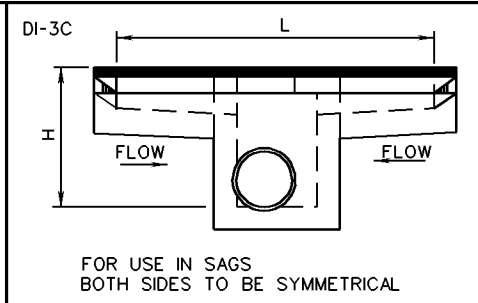
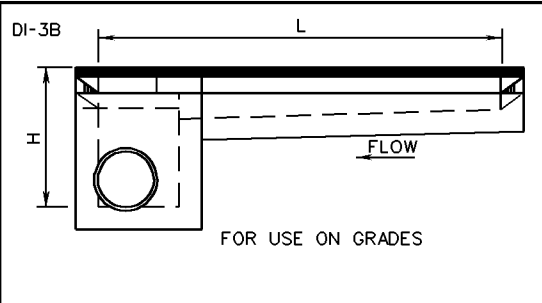
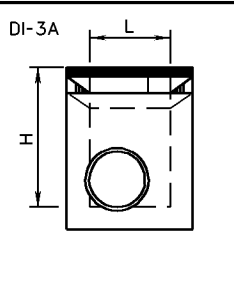

DETAIL WHEN USED ADJACENT TO CURB WITHOUT GUTTER

VDOT	
ROAD AND BRIDGE STANDARDS	
SHEET 1 OF 2	REVISION DATE
104.09	08/10

STANDARD CURB DROP INLET

12" - 30" PIPE: MAXIMUM DEPTH (H) - 8'

VIRGINIA DEPARTMENT OF TRANSPORTATION

SPECIFICATION REFERENCE
233 302

TABLE OF QUANTITIES

DI-3A, 3B, 3C

TYPE	L	AREA OF SLOT		REINFORCING STEEL														WEIGHT	
		Ft.	Sq. Ft.	Concrete	BARS A		BARS B		BARS C		BARS D		BARS E		BARS F		BARS G		
				Cu. Yds.	No.	Lin. Ft. *	No.	Lin. Ft. *	No.	Lin. Ft. *	No.	Lin. Ft.*	No.	Lin. Ft.*	No.	Lin. Ft.*	No.		Lin. Ft.*
DI-3A	2'-6"	1.15	2.26	-	-	-	-	1	5'-7"	3	3'-2"	-	-	-	-	6	1'-0"	22	
DI-3B	4'	1.83	2.59	5	1'-6"	2	6'-7" to 6'-10"	3	5'-7"	3	3'-2"	4	1'-6"	3	1'-6"	4	1'-0"	64	
	6'	2.75	3.02	5	3'-6"	6	6'-7" to 6'-10"	3	5'-7"	3	3'-2"	4	3'-6"	3	1'-6"	4	1'-0"	111	
	8'	3.67	3.46	5	5'-6"	10	6'-7" to 6'-10"	3	5'-7"	3	3'-2"	4	5'-6"	3	1'-6"	4	1'-0"	158	
	10'	4.58	3.90	5	7'-6"	14	6'-7" to 6'-10"	3	5'-7"	3	3'-2"	4	7'-6"	3	1'-6"	4	1'-0"	204	
	12'	5.50	4.34	5	9'-6"	18	6'-7" to 6'-10"	3	5'-7"	3	3'-2"	4	9'-6"	3	1'-6"	4	1'-0"	251	
	14'	6.42	4.78	5	11'-6"	22	6'-7" to 6'-10"	3	5'-7"	3	3'-2"	4	11'-6"	3	1'-6"	4	1'-0"	298	
	16'	7.33	5.22	5	13'-6"	26	6'-7" to 6'-10"	3	5'-7"	3	3'-2"	4	13'-6"	3	1'-6"	4	1'-0"	345	
	18'	8.25	5.66	5	15'-6"	30	6'-7" to 6'-10"	3	5'-7"	3	3'-2"	4	15'-6"	3	1'-6"	4	1'-0"	391	
	20'	9.17	6.09	5	17'-6"	34	6'-7" to 6'-10"	3	5'-7"	3	3'-2"	4	17'-6"	3	1'-6"	4	1'-0"	438	
	DI-3C	6'	2.75	3.01	10	1'-9"	4	6'-7" to 6'-10"	5	5'-7"	3	3'-2"	8	1'-9"	6	1'-6"	2	1'-0"	111
8'		3.67	3.45	10	2'-9"	8	6'-7" to 6'-10"	5	5'-7"	3	3'-2"	8	2'-9"	6	1'-6"	2	1'-0"	158	
10'		4.58	3.89	10	3'-9"	12	6'-7" to 6'-10"	5	5'-7"	3	3'-2"	8	3'-9"	6	1'-6"	2	1'-0"	205	
12'		5.50	4.33	10	4'-9"	16	6'-7" to 6'-10"	5	5'-7"	3	3'-2"	8	4'-9"	6	1'-6"	2	1'-0"	252	
14'		6.42	4.77	10	5'-9"	20	6'-7" to 6'-10"	5	5'-7"	3	3'-2"	8	5'-9"	6	1'-6"	2	1'-0"	298	
16'		7.33	5.21	10	6'-9"	24	6'-7" to 6'-10"	5	5'-7"	3	3'-2"	8	6'-9"	6	1'-6"	2	1'-0"	345	
18'		8.25	5.65	10	7'-9"	28	6'-7" to 6'-10"	5	5'-7"	3	3'-2"	8	7'-9"	6	1'-6"	2	1'-0"	392	
20'		9.17	6.09	10	8'-9"	32	6'-7" to 6'-10"	5	5'-7"	3	3'-2"	8	8'-9"	6	1'-6"	2	1'-0"	439	

NOTES

1. DEPTH OF INLET (H) TO BE SHOWN ON PLANS.
2. THE "H" DIMENSION SHOWN ON THE STANDARDS AND SPECIFIED ON THE PLANS WILL BE MEASURED FROM THE INVERT OF THE OUTFALL PIPE TO THE TOP OF THE STRUCTURE. PLAN "H" DIMENSIONS ARE APPROXIMATE ONLY FOR ESTIMATING PURPOSES AND THE ACTUAL DIMENSIONS SHALL BE DETERMINED BY THE CONTRACTOR FROM FIELD CONDITIONS.
3. WHEN SPECIFIED ON THE PLANS THE INVERT IS TO BE SHAPED IN ACCORDANCE WITH STANDARD IS-1. THE COST OF FURNISHING AND PLACING ALL MATERIALS INCIDENTAL TO THE SHAPING IS TO BE INCLUDED IN THE BID PRICE FOR THE STRUCTURE.
4. IN THE EVENT THE INVERT OF THE OUTFALL PIPE IS HIGHER THAN THE BOTTOM OF THE STRUCTURE, THE INVERT OF THE STRUCTURE SHALL BE SHAPED WITH CEMENT MORTAR TO PREVENT STANDING OR PONDING OF WATER IN THE STRUCTURE. THE COST OF FURNISHING AND PLACING ALL MATERIALS INCIDENTAL TO THE SHAPING IS TO BE INCLUDED IN THE BID PRICE FOR THE STRUCTURE.
5. STEPS ARE TO BE PROVIDED WHEN H IS 4'-0" OR GREATER. FOR DETAILS SEE STANDARD ST-1.
6. THIS ITEM MAY BE PRECAST OR CAST-IN-PLACE.
7. #4 X 8" SMOOTH DOWELS AT APPROXIMATELY 12" C-C TO BE PLACED IN ALL AREAS ADJACENT TO BUTTING CONCRETE TO PREVENT SETTLEMENT.
8. 3" DIAMETER WEEP HOLE TO BE LOCATED TO DRAIN SUBBASE MATERIAL. WEEP HOLE WITH 12"X12" PLASTIC HARDWARE CLOTH 1/4" MESH OR GALVANIZED STEEL WIRE, MINIMUM WIRE DIAMETER 0.03", NUMBER 4 MESH HARDWARE CLOTH ANCHORED FIRMLY TO THE OUTSIDE OF THE STRUCTURE.
9. ALL REINFORCING STEEL SHALL HAVE A MIN. COVER OF 2".
10. ALL REINFORCING STEEL TO BE CUT CLEAR OF ALL OPENINGS BY 2".
11. CAST-IN PLACE CONCRETE IS TO BE CLASS A3 (3000 PSI). PRECAST CONCRETE IS TO BE 4000 PSI.
12. LENGTH OF SLOT (L) WILL, IN EVERY CASE, BE SHOWN ON PLANS.
13. IF INLET IS CONSTRUCTED IN MEDIAN CURB OR WITH INTEGRAL CURB, GUTTER IS TO BE OMITTED (SEE DETAIL).
14. STANDARD INLETS MAY BE CONSTRUCTED WITH CONCRETE BLOCKS IN ACCORDANCE WITH THE DETAILS SHOWN ON STANDARD DRAWING DI-MB.
15. THIS AREA MAY BE EARTHEN, IN WHICH CASE THE EXPANSION JOINTS WILL APPLY ONLY TO CURB AND GUTTER.
16. CONCRETE QUANTITIES SHOWN ARE FOR DEPTH (H) OF 5'-2" WITHOUT PIPES. THE AMOUNT DISPLACED BY PIPES MUST BE DEDUCTED TO OBTAIN TRUE QUANTITIES. FOR INLETS OF DIFFERENT DEPTHS ADD OR SUBTRACT 0.32 CUBIC YARDS OF CONCRETE FOR EACH FOOT OF DEPTH.
17. LENGTH OF ANGLE IRON AS SHOWN ON SHEET 1 OF 2 IS TO BE L +16" AT 4.10 LBS./FT..
18. * DENOTES LENGTH OF ONE (1) BAR.
19. ALL REINFORCING BARS TO BE #5.
20. WHEN INLET IS USED IN 4'-0" MEDIAN, BACK OF INLET IS TO BE SHAPED TO CONFORM TO PROPOSED CURB.

SPECIFICATION REFERENCE

233
302

STANDARD CURB DROP INLET

12" - 30" PIPE: MAXIMUM DEPTH (H) = 8'

VIRGINIA DEPARTMENT OF TRANSPORTATION

VDOT

ROAD AND BRIDGE STANDARDS

REVISION DATE

SHEET 2 OF 2

104.10

NOTES

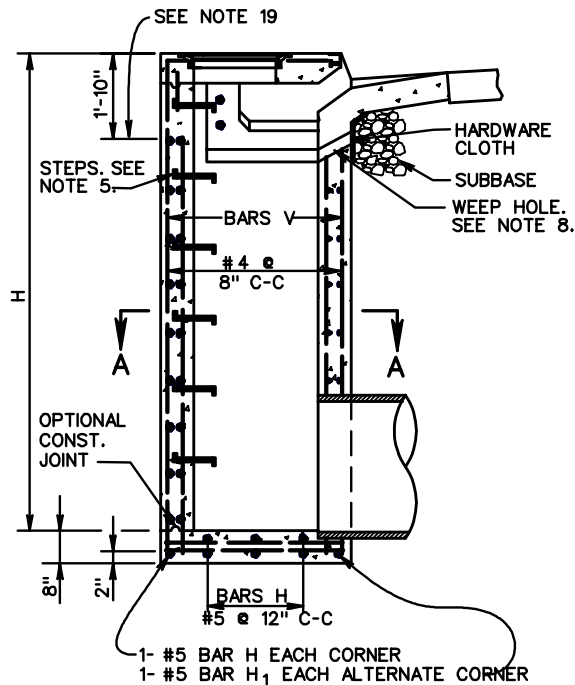
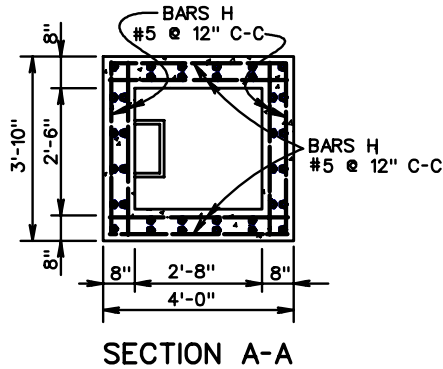

- DEPTH OF INLET (H) TO BE SHOWN ON PLANS. MINIMUM DEPTH (H) TO BE 8'-0". MAXIMUM DEPTH TO BE 20'-0". FOR INLETS LESS THAN 8' USE STANDARD DI-3A, 3B, 3C.
- THE "H" DIMENSION SHOWN ON THE STANDARDS AND SPECIFIED ON THE PLANS WILL BE MEASURED FROM THE INVERT OF THE OUTFALL PIPE TO THE TOP OF THE STRUCTURE. PLAN "H" DIMENSIONS ARE APPROXIMATE ONLY FOR ESTIMATING PURPOSES AND THE ACTUAL DIMENSIONS SHALL BE DETERMINED BY THE CONTRACTOR FROM FIELD CONDITIONS.
- WHEN SPECIFIED ON THE PLANS THE INVERT IS TO BE SHAPED IN ACCORDANCE WITH STANDARD IS-1. THE COST OF FURNISHING AND PLACING ALL MATERIALS INCIDENTAL TO THE SHAPING IS TO BE INCLUDED IN THE BID PRICE FOR THE STRUCTURE.
- IN THE EVENT THE INVERT OF THE OUTFALL PIPE IS HIGHER THAN THE BOTTOM OF THE STRUCTURE, THE INVERT OF THE STRUCTURE SHALL BE SHAPED WITH CEMENT MORTAR TO PREVENT STANDING OR PONDING OF WATER IN THE STRUCTURE. THE COST OF FURNISHING AND PLACING ALL MATERIALS INCIDENTAL TO THE SHAPING IS TO BE INCLUDED IN THE BID PRICE FOR THE STRUCTURE.
- STEPS ARE REQUIRED. FOR DETAILS SEE STANDARD ST-1.
- THIS ITEM MAY BE PRECAST OR CAST-IN-PLACE.
- # 4 X 8" SMOOTH DOWELS AT APPROXIMATELY 12" C-C TO BE PLACED IN ALL AREAS ADJACENT TO ABUTTING CONCRETE TO PREVENT SETTLEMENT. IN LIEU OF DOWELS A 2" X 4" NOTCH MAY BE PROVIDED. SEE STANDARD T-DI-3, 4 FOR ALTERNATE DESIGN.
- 3" DIAMETER WEEP HOLE TO BE LOCATED TO DRAIN SUBBASE MATERIAL. WEEP HOLE WITH 12"X12" PLASTIC HARDWARE CLOTH 1/4" MESH OR GALVANIZED STEEL WIRE, MINIMUM WIRE DIAMETER 0.03", NUMBER 4 MESH HARDWARE CLOTH ANCHORED FIRMLY TO THE OUTSIDE OF THE STRUCTURE.
- ALL REINFORCING STEEL SHALL HAVE A MIN. COVER OF 2".
- ALL REINFORCING STEEL TO BE CUT CLEAR OF ALL OPENINGS BY 2".
- CAST-IN PLACE CONCRETE IS TO BE CLASS A3 (3000 PSI). PRECAST CONCRETE IS TO BE 4000 PSI.
- LENGTH OF SLOT (L) WILL, IN EVERY CASE, BE SHOWN ON PLANS.
- WHEN INLET IS USED IN 4' MEDIAN BACK OF INLET IS TO BE SHAPED TO CONFORM WITH PROPOSED CURB.
- IF OPTIONAL CONSTRUCTION JOINT IS USED IT IS TO BE KEYPED. ALL SPLICES IN BARS V TO BE A MINIMUM OF 40 DIAMETERS (20").
- FOR PLAN VIEW OF INLET SEE STANDARD DI-3A, 3B, 3C.
- QUANTITIES SHOWN ARE FOR MINIMUM INLETS OF EACH TYPE. FOR INLETS OF GREATER DEPTH (H) OR LONGER SLOT (L) INCREMENTS SHOWN PER FOOT MUST BE ADDED. THE AMOUNT OF CONCRETE AND STEEL DISPLACED BY PIPES MUST BE DEDUCTED TO OBTAIN TRUE QUANTITIES.
- FOR NUMBER OF BARS A-G REQUIRED AND LENGTHS SEE SHEET 104.10.
- FOR DESCRIPTION AND LOCATION OF DIMENSION L SEE SHEET 104.09.
- FOR ALL DETAILS, DIMENSIONS, AND REINFORCING STEEL ABOVE THIS LINE SEE STANDARD DI-3A, 3B, 3C.

SCHEDULE OF REINFORCING STEEL					
BARS H		BARS H ₁		BARS V	
NO. REQ'D.	LENGTH	NO. REQ'D.	LENGTH	NO. REQ'D.	LENGTH
4x(H+1)	3'-6"	4x(H+1)	3'-8"	36	H-1'-4"

APPROXIMATE QUANTITIES FOR MINIMUM 8' DEPTH INLET			
TYPE	DIMENSION L SEE NOTE 18	REINFORCING STEEL	CONCRETE
	Lin. Ft.	Lbs.	Cu. Yds.
3AA	2'-6"	452	3.14
3BB	4'-0"	494	3.47
3CC	6'-0"	541	3.89

INCREMENTS TO BE ADDED FOR EACH ADDITIONAL FOOT OF DEPTH (H) AND/OR SLOT LENGTH (L)			
H		L	
CONCRETE	STEEL	CONCRETE	STEEL
Cu. Yds.	Lbs.	Cu. Yds.	Lbs.
0.317	54	-	-
0.317	54	0.22	23.5
0.317	54	0.22	23.5

SECTION THROUGH ELEVATION



ROAD AND BRIDGE STANDARDS

SHEET 1 OF 1

REVISION DATE

104.11

STANDARD CURB DROP INLET

12" - 30" PIPE: DEPTH (H) 8' TO 20'

VIRGINIA DEPARTMENT OF TRANSPORTATION

SPECIFICATION REFERENCE

233
302

TABLE OF QUANTITIES

TYPE	L	AREA OF SLOT	REINFORCING STEEL												WEIGHT					
			CONCRETE	BARS A		BARS B		BARS C		BARS D		BARS E		BARS F		BARS G		BARS H		
			Cu. Yds.	No.	Lin. Ft.*	No.	Lin. Ft.*	No.	Lin. Ft.*	No.	Lin. Ft.*	No.	Lin. Ft.*	No.		Lin. Ft.*	No.	Lin. Ft.*	No.	Lin. Ft.*
DI-3D	2'-6"	1.15	3.21	5	3'-2"	-	-	1	8'-0"	3	3'-2"	-	-	-	-	10	1'-0"	4	3'-1"	58
DI-3E	4'	1.83	3.54	5	4'-8"	2	6'-7" to 6'-10"	3	8'-0"	3	3'-2"	4	1'-6"	3	1'-6"	8	1'-0"	4	3'-1"	106
	6'	2.75	3.97	5	6'-8"	6	6'-7" to 6'-10"	3	8'-0"	3	3'-2"	4	3'-6"	3	1'-6"	8	1'-0"	4	3'-1"	153
	8'	3.67	4.41	5	8'-8"	10	6'-7" to 6'-10"	3	8'-0"	3	3'-2"	4	5'-6"	3	1'-6"	8	1'-0"	4	3'-1"	199
	10'	4.58	4.85	5	10'-8"	14	6'-7" to 6'-10"	3	8'-0"	3	3'-2"	4	7'-6"	3	1'-6"	8	1'-0"	4	3'-1"	246
	12'	5.50	5.29	5	12'-8"	18	6'-7" to 6'-10"	3	8'-0"	3	3'-2"	4	9'-6"	3	1'-6"	8	1'-0"	4	3'-1"	293
	14'	6.42	5.73	5	14'-8"	22	6'-7" to 6'-10"	3	8'-0"	3	3'-2"	4	11'-6"	3	1'-6"	8	1'-0"	4	3'-1"	340
	16'	7.33	6.17	5	16'-8"	26	6'-7" to 6'-10"	3	8'-0"	3	3'-2"	4	13'-6"	3	1'-6"	8	1'-0"	4	3'-1"	386
	18'	8.25	6.61	5	18'-8"	30	6'-7" to 6'-10"	3	8'-0"	3	3'-2"	4	15'-6"	3	1'-6"	8	1'-0"	4	3'-1"	433
	20'	9.17	7.04	5	20'-8"	34	6'-7" to 6'-10"	3	8'-0"	3	3'-2"	4	17'-6"	3	1'-6"	8	1'-0"	4	3'-1"	480
DI-3F	6'	2.75	3.96	5	6'-8"	4	6'-7" to 6'-10"	5	8'-0"	3	3'-2"	8	1'-9"	6	1'-6"	6	1'-0"	4	3'-1"	158
	8'	3.67	4.40	5	8'-8"	8	6'-7" to 6'-10"	5	8'-0"	3	3'-2"	8	2'-9"	6	1'-6"	6	1'-0"	4	3'-1"	205
	10'	4.58	4.84	5	10'-8"	12	6'-7" to 6'-10"	5	8'-0"	3	3'-2"	8	3'-9"	6	1'-6"	6	1'-0"	4	3'-1"	251
	12'	5.50	5.28	5	12'-8"	16	6'-7" to 6'-10"	5	8'-0"	3	3'-2"	8	4'-9"	6	1'-6"	6	1'-0"	4	3'-1"	298
	14'	6.42	5.72	5	14'-8"	20	6'-7" to 6'-10"	5	8'-0"	3	3'-2"	8	5'-9"	6	1'-6"	6	1'-0"	4	3'-1"	345
	16'	7.33	6.16	5	16'-8"	24	6'-7" to 6'-10"	5	8'-0"	3	3'-2"	8	6'-9"	6	1'-6"	6	1'-0"	4	3'-1"	392
	18'	8.25	6.60	5	18'-8"	28	6'-7" to 6'-10"	5	8'-0"	3	3'-2"	8	7'-9"	6	1'-6"	6	1'-0"	4	3'-1"	438
		20'	9.17	7.04	5	20'-8"	32	6'-7" to 6'-10"	5	8'-0"	3	3'-2"	8	8'-9"	6	1'-6"	6	1'-0"	4	3'-1"

NOTES

1. DEPTH OF INLET (H) TO BE SHOWN ON PLANS.
2. THE "H" DIMENSION SHOWN ON THE STANDARDS AND SPECIFIED ON THE PLANS WILL BE MEASURED FROM THE INVERT OF THE OUTFALL PIPE TO THE TOP OF THE STRUCTURE. PLAN "H" DIMENSIONS ARE APPROXIMATE ONLY FOR ESTIMATING PURPOSES AND THE ACTUAL DIMENSIONS SHALL BE DETERMINED BY THE CONTRACTOR FROM FIELD CONDITIONS.
3. WHEN SPECIFIED ON THE PLANS THE INVERT IS TO BE SHAPED IN ACCORDANCE WITH STANDARD IS-1. THE COST OF FURNISHING AND PLACING ALL MATERIALS INCIDENTAL TO THE SHAPING IS TO BE INCLUDED IN THE BID PRICE FOR THE STRUCTURE.
4. IN THE EVENT THE INVERT OF THE OUTFALL PIPE IS HIGHER THAN THE BOTTOM OF THE STRUCTURE, THE INVERT OF THE STRUCTURE SHALL BE SHAPED WITH CEMENT MORTAR TO PREVENT STANDING OR PONDING OF WATER IN THE STRUCTURE. THE COST OF FURNISHING AND PLACING ALL MATERIALS INCIDENTAL TO THE SHAPING IS TO BE INCLUDED IN THE BID PRICE FOR THE STRUCTURE.
5. STEPS ARE TO BE PROVIDED WHEN H IS 4'-0" OR GREATER. FOR DETAILS SEE STANDARD ST-1.
6. THIS ITEM MAY BE PRECAST OR CAST-IN-PLACE.
7. # 4 X 8" SMOOTH DOWELS AT APPROXIMATELY 12" C-C TO BE PLACED IN ALL AREAS ADJACENT TO ABUTTING CONCRETE TO PREVENT SETTLEMENT.
8. 3" DIAMETER WEEP HOLE TO BE LOCATED TO DRAIN SUBBASE MATERIAL. WEEP HOLE WITH 12"X12" PLASTIC HARDWARE CLOTH 1/4" MESH OR GALVANIZED STEEL WIRE, MINIMUM WIRE DIAMETER 0.03", NUMBER 4 MESH HARDWARE CLOTH ANCHORED FIRMLY TO THE OUTSIDE OF THE STRUCTURE.
9. ALL REINFORCING STEEL SHALL HAVE A MIN. COVER OF 2".
10. ALL REINFORCING STEEL TO BE CUT CLEAR OF ALL OPENINGS BY 2".
11. CAST-IN PLACE CONCRETE IS TO BE CLASS A3 (3000 PSI). PRECAST CONCRETE IS TO BE 4000 PSI.
12. LENGTH OF SLOT (L) WILL, IN EVERY CASE, BE SHOWN ON PLANS.
13. IF INLET IS CONSTRUCTED IN MEDIAN CURB OR WITH INTEGRAL CURB, GUTTER IS TO BE OMITTED (SEE DETAIL).
14. STANDARD INLETS MAY BE CONSTRUCTED WITH CONCRETE BLOCKS IN ACCORDANCE WITH THE DETAILS SHOWN ON STANDARD DRAWING DI-MB.
15. THIS AREA MAY BE EARTHEN, IN WHICH CASE THE EXPANSION JOINTS WILL APPLY ONLY TO CURB AND GUTTER.
16. CONCRETE QUANTITIES SHOWN ARE FOR DEPTH (H) OF 5'-2" WITHOUT PIPES. THE AMOUNT DISPLACED BY PIPES MUST BE DEDUCTED TO OBTAIN TRUE QUANTITIES. FOR INLETS OF DIFFERENT DEPTHS ADD OR SUBTRACT 0.44 CUBIC YARDS OF CONCRETE FOR EACH FOOT OF DEPTH.
17. LENGTH OF ANGLE IRON AS SHOWN ON SHEET 1 OF 2 IS TO BE L+16" AT 4.10 LBS./FT..
18. * DENOTES LENGTH OF ONE (1) BAR.
19. ALL REINFORCING BARS TO BE #5.



ROAD AND BRIDGE STANDARDS

STANDARD CURB DROP INLET (WITH UTILITY SPACE)

SPECIFICATION REFERENCE

SHEET 2 OF 2

REVISION DATE

12" - 30" PIPE: MAXIMUM DEPTH (H) - 8'

233
302

104.13

VIRGINIA DEPARTMENT OF TRANSPORTATION

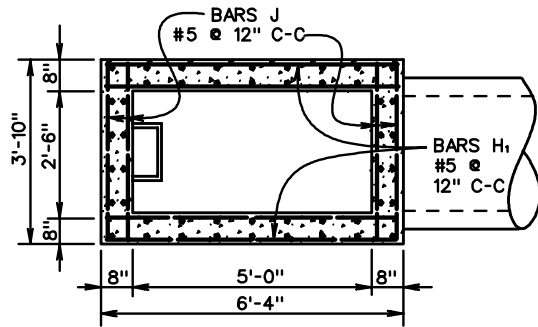

SECTION A-A

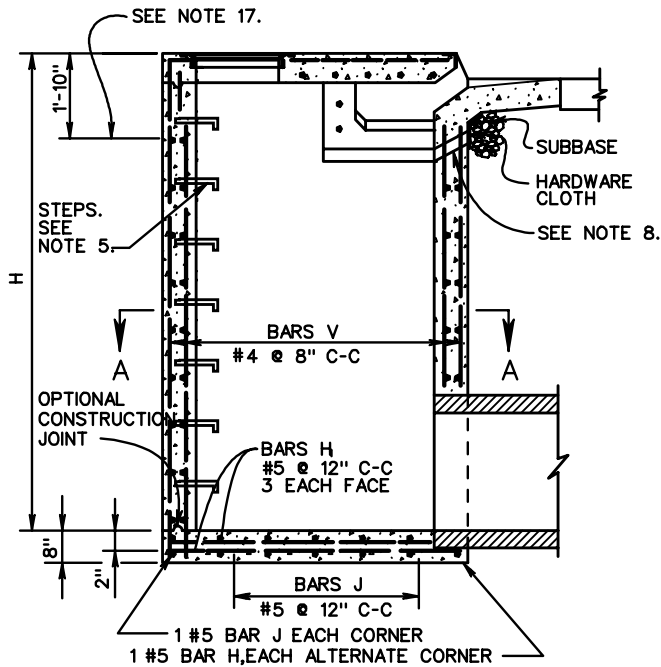

SECTION THROUGH ELEVATION

SCHEDULE OF REINFORCING STEEL					
BARS J		BARS H ₁		BARS V	
NO. REQ'D.	LENGTH	NO. REQ'D.	LENGTH	NO. REQ'D.	LENGTH
4X(H + 2)	3'-6"	4X(H + 1)	6'-0"	52	H - 1'-4"

- ### NOTES
- DEPTH OF INLET (H) TO BE SHOWN ON PLANS. MINIMUM DEPTH (H) TO BE 8'-0", MAXIMUM DEPTH TO BE 20'-0". FOR INLETS LESS THAN 8' USE STANDARD DI-3D, 3E, 3F.
 - THE "H" DIMENSION SHOWN ON THE STANDARDS AND SPECIFIED ON THE PLANS WILL BE MEASURED FROM THE INVERT OF THE OUTFALL PIPE TO THE TOP OF THE STRUCTURE. PLAN "H" DIMENSIONS ARE APPROXIMATE ONLY FOR ESTIMATING PURPOSES AND THE ACTUAL DIMENSIONS SHALL BE DETERMINED BY THE CONTRACTOR FROM FIELD CONDITIONS.
 - WHEN SPECIFIED ON THE PLANS THE INVERT IS TO BE SHAPED IN ACCORDANCE WITH STANDARD IS-1. THE COST OF FURNISHING AND PLACING ALL MATERIALS INCIDENTAL TO THE SHAPING IS TO BE INCLUDED IN THE BID PRICE FOR THE STRUCTURE.
 - IN THE EVENT THE INVERT OF THE OUTFALL PIPE IS HIGHER THAN THE BOTTOM OF THE STRUCTURE, THE INVERT OF THE STRUCTURE SHALL BE SHAPED WITH CEMENT MORTAR TO PREVENT STANDING OR PONDING OF WATER IN THE STRUCTURE. THE COST OF FURNISHING AND PLACING ALL MATERIALS INCIDENTAL TO THE SHAPING IS TO BE INCLUDED IN THE BID PRICE FOR THE STRUCTURE.
 - STEPS ARE REQUIRED. FOR DETAILS SEE STANDARD ST-1.
 - THIS ITEM MAY BE PRECAST OR CAST-IN-PLACE.
 - # 4 X 8" SMOOTH DOWELS AT APPROXIMATELY 12" C-C TO BE PLACED IN ALL AREAS ADJACENT TO ABUTTING CONCRETE TO PREVENT SETTLEMENT. IN LIEU OF DOWELS A 2" X 4" NOTCH MAY BE PROVIDED. SEE STANDARD T-DI-3, 4 FOR ALTERNATE DESIGN.
 - 3" DIAMETER WEEP HOLE TO BE LOCATED TO DRAIN SUBBASE MATERIAL. WEEP HOLE WITH 12"X12" PLASTIC HARDWARE CLOTH 1/4" MESH OR GALVANIZED STEEL WIRE, MINIMUM WIRE DIAMETER 0.03", NUMBER 4 MESH HARDWARE CLOTH ANCHORED FIRMLY TO THE OUTSIDE OF THE STRUCTURE.
 - ALL REINFORCING STEEL SHALL HAVE A MIN. COVER OF 2".
 - ALL REINFORCING STEEL TO BE CUT CLEAR OF ALL OPENINGS BY 2".
 - CAST-IN PLACE CONCRETE IS TO BE CLASS A3 (3000 PSI). PRECAST CONCRETE IS TO BE 4000 PSI.
 - LENGTH OF SLOT (L) WILL, IN EVERY CASE, BE SHOWN ON PLANS.
 - THIS STANDARD IS INTENDED FOR USE IN CURB AND GUTTER SITUATIONS ONLY.
 - IF OPTIONAL CONSTRUCTION JOINT IS USED IT IS TO BE KEYED. ALL SPLICES IN BARS V TO BE A MINIMUM OF 40 DIAMETER (20").
 - FOR PLAN VIEW OF INLET SEE STANDARD DI-3D, 3E, 3F.
 - CONCRETE QUANTITIES SHOWN ARE FOR MINIMUM INLETS OF EACH TYPE. FOR INLETS OF GREATER DEPTH (H) OR LONGER SLOTS (L) INCREMENTS SHOWN PER FOOT MUST BE ADDED. THE AMOUNT DISPLACED BY PIPES MUST BE DEDUCTED TO OBTAIN TRUE QUANTITIES.
 - FOR ALL DETAILS, DIMENSIONS, AND REINFORCING STEEL ABOVE THIS LINE SEE STANDARD DI-3D, 3E, 3F.
 - PROVIDE SAFETY SLABS WHEN SPECIFIED ON THE PLANS.
 - FOR DESCRIPTION AND LOCATION OF DIMENSION L SEE SHEET 104.12.
 - FOR NUMBER OF BARS A-H REQUIRED AND LENGTHS SEE SHEET 104.13.

APPROXIMATE QUANTITIES FOR MINIMUM 8' DEPTH INLET

TYPE	DIMENSION L SEE NOTE 19	REINFORCING STEEL	CONCRETE
	LIN. FT.	LBS.	CU. YDS.
3DD	2'-6"	661	4.38
3EE	4'-0"	709	4.71
3FF	6'-0"	761	5.13

INCREMENTS TO BE ADDED FOR EACH ADDITIONAL FOOT OF DEPTH (H) AND/OR SLOT LENGTH (L)

H		L	
CU. YDS. CONCRETE	LBS. STEEL	CU. YDS. CONCRETE	LBS. STEEL
0.431	75	-	-
0.431	75	0.22	23.5
0.431	75	0.22	23.5

SPECIFICATION REFERENCE

233

302

STANDARD CURB DROP INLET (WITH UTILITY SPACE)

12" - 30" PIPE: DEPTH (H) = 8' TO 20'

VIRGINIA DEPARTMENT OF TRANSPORTATION

VDOT

ROAD AND BRIDGE STANDARDS

REVISION DATE

SHEET 1 OF 1

104.14

DI-4A, 4B, 4C

FOR DETAILS OF INLET FRAME & COVER SEE STANDARD IC-2.

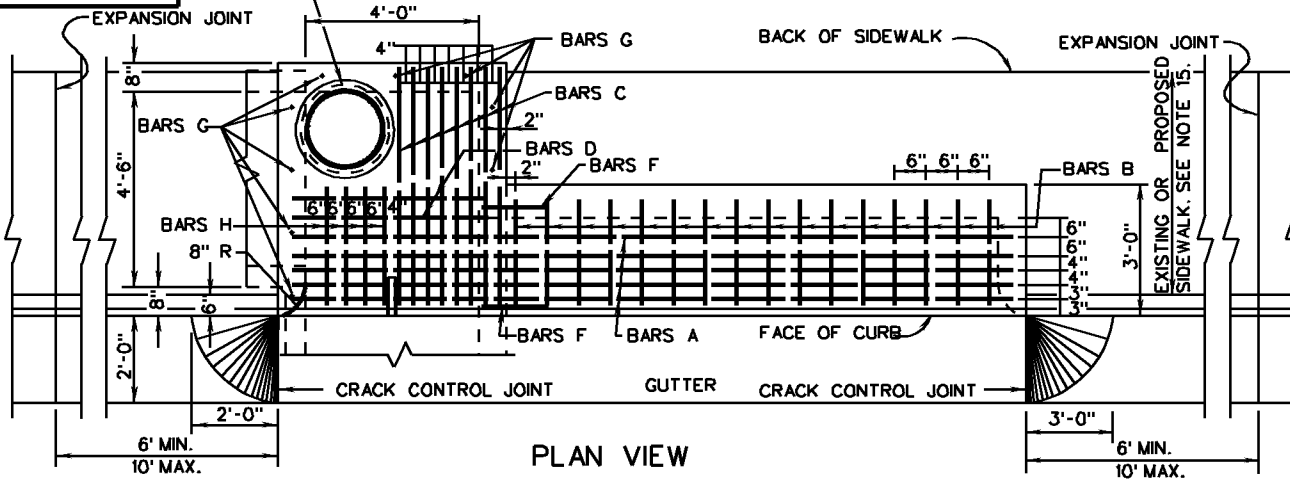

GALVANIZED PLATE TO BE BENT ON AN ANGLE OF 68°30' AND IS TO BE ANCHORED WITH 1/2" X 4" STUD SHEAR CONNECTORS WELDED TO BENT PLATE AT 2'-0" C-C.

TYPE A NOSE DETAIL SHALL BE USED WITH CG-3 AND CG-7 STANDARDS. TYPE B NOSE DETAIL SHALL BE USED WITH CG-2 AND CG-6 STANDARDS.

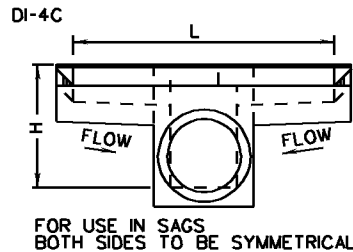
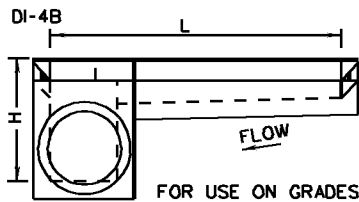
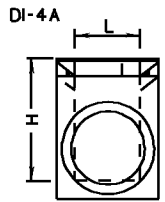
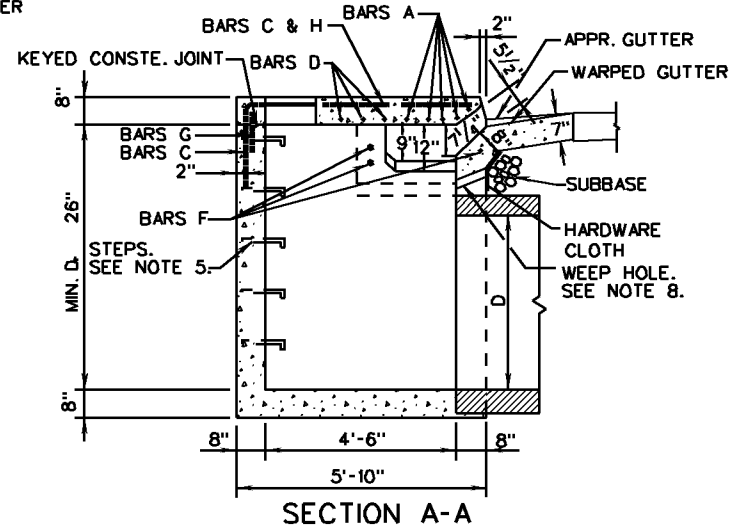
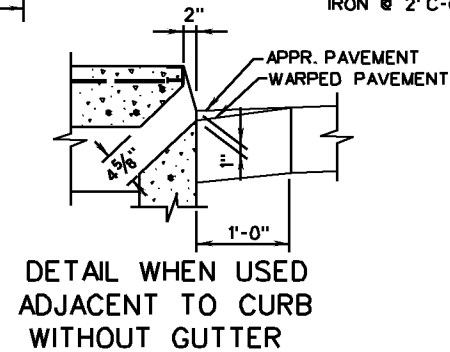
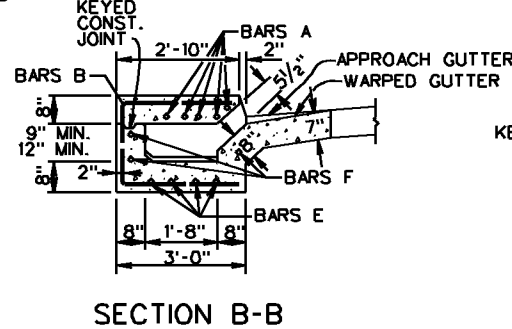
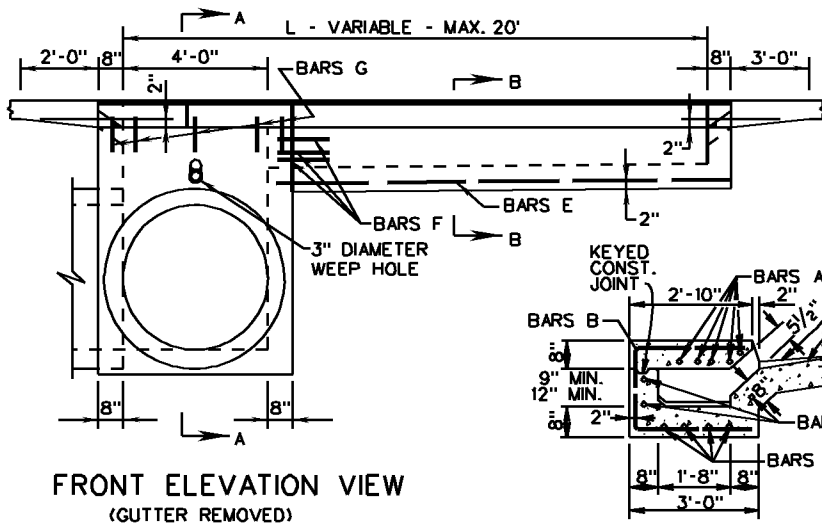
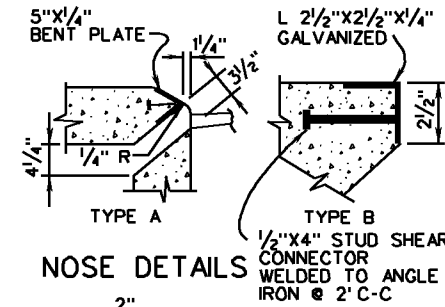

VDOT

ROAD AND BRIDGE STANDARDS

SHEET 1 OF 2

REVISION DATE

104.15

10/09

STANDARD CURB DROP INLET

36" - 48" PIPE: MAXIMUM DEPTH (H) = 8'

VIRGINIA DEPARTMENT OF TRANSPORTATION

SPECIFICATION
REFERENCE

233
302

TABLE OF QUANTITIES

DI-4A, 4B, 4C

TYPE	L Ft.	AREA OF SLOT Sq. Ft.	Concrete Cu. Yds.	REINFORCING STEEL												WEIGHT Lbs.				
				BARS A		BARS B		BARS C		BARS D		BARS E		BARS F			BARS G		BARS H	
				No.	Lin. Ft. *	No.	Lin. Ft. *	No.	Lin. Ft. *	No.	Lin. Ft. *	No.	Lin. Ft. *	No.	Lin. Ft. *		No.	Lin. Ft. *	No.	Lin. Ft. *
DI-4A	4'	1.83	4.65	5	4'-8"	-	-	6	7'-6"	2	4'-8"	-	-	-	-	11	1'-0"	4	2'-8"	104
DI-4B	6'	2.75	5.07	5	6'-8"	3	6'-7" to 6'-10"	8	7'-6"	2	4'-8"	4	2'-0"	3	1'-6"	9	1'-0"	4	2'-8"	162
	8'	3.67	5.51	5	8'-8"	7	6'-7" to 6'-10"	8	7'-6"	2	4'-8"	4	4'-0"	3	1'-6"	9	1'-0"	4	2'-8"	209
	10'	4.58	5.96	5	10'-8"	11	6'-7" to 6'-10"	8	7'-6"	2	4'-8"	4	6'-0"	3	1'-6"	9	1'-0"	4	2'-8"	256
	12'	5.50	6.40	5	12'-8"	15	6'-7" to 6'-10"	8	7'-6"	2	4'-8"	4	8'-0"	3	1'-6"	9	1'-0"	4	2'-8"	302
	14'	6.42	6.85	5	14'-8"	19	6'-7" to 6'-10"	8	7'-6"	2	4'-8"	4	10'-0"	3	1'-6"	9	1'-0"	4	2'-8"	349
	16'	7.33	7.30	5	16'-8"	23	6'-7" to 6'-10"	8	7'-6"	2	4'-8"	4	12'-0"	3	1'-6"	9	1'-0"	4	2'-8"	396
	18'	8.25	7.74	5	18'-8"	27	6'-7" to 6'-10"	8	7'-6"	2	4'-8"	4	14'-0"	3	1'-6"	9	1'-0"	4	2'-8"	443
DI-4C	20'	9.17	8.19	5	20'-8"	31	6'-7" to 6'-10"	8	7'-6"	2	4'-8"	4	16'-0"	3	1'-6"	9	1'-0"	4	2'-8"	489
	8'	3.67	5.48	5	8'-8"	6	6'-7" to 6'-10"	10	7'-6"	2	4'-8"	8	2'-0"	6	1'-6"	7	1'-0"	4	2'-8"	220
	10'	4.58	5.92	5	10'-8"	10	6'-7" to 6'-10"	10	7'-6"	2	4'-8"	8	3'-0"	6	1'-6"	7	1'-0"	4	2'-8"	267
	12'	5.50	6.37	5	12'-8"	14	6'-7" to 6'-10"	10	7'-6"	2	4'-8"	8	4'-0"	6	1'-6"	7	1'-0"	4	2'-8"	314
	14'	6.42	6.81	5	14'-8"	18	6'-7" to 6'-10"	10	7'-6"	2	4'-8"	8	5'-0"	6	1'-6"	7	1'-0"	4	2'-8"	360
	16'	7.33	7.26	5	16'-8"	22	6'-7" to 6'-10"	10	7'-6"	2	4'-8"	8	6'-0"	6	1'-6"	7	1'-0"	4	2'-8"	407
	18'	8.25	7.70	5	18'-8"	26	6'-7" to 6'-10"	10	7'-6"	2	4'-8"	8	7'-0"	6	1'-6"	7	1'-0"	4	2'-8"	454
	20'	9.17	8.15	5	20'-8"	30	6'-7" to 6'-10"	10	7'-6"	2	4'-8"	8	8'-0"	6	1'-6"	7	1'-0"	4	2'-8"	501

NOTES

1. DEPTH OF INLET (H) TO BE SHOWN ON PLANS.
2. THE "H" DIMENSION SHOWN ON THE STANDARDS AND SPECIFIED ON THE PLANS WILL BE MEASURED FROM THE INVERT OF THE OUTFALL PIPE TO THE TOP OF THE STRUCTURE. PLAN "H" DIMENSIONS ARE APPROXIMATE ONLY FOR ESTIMATING PURPOSES AND THE ACTUAL DIMENSIONS SHALL BE DETERMINED BY THE CONTRACTOR FROM FIELD CONDITIONS.
3. WHEN SPECIFIED ON THE PLANS THE INVERT IS TO BE SHAPED IN ACCORDANCE WITH STANDARD IS-1. THE COST OF FURNISHING AND PLACING ALL MATERIALS INCIDENTAL TO THE SHAPING IS TO BE INCLUDED IN THE BID PRICE FOR THE STRUCTURE.
4. IN THE EVENT THE INVERT OF THE OUTFALL PIPE IS HIGHER THAN THE BOTTOM OF THE STRUCTURE, THE INVERT OF THE STRUCTURE SHALL BE SHAPED WITH CEMENT MORTAR TO PREVENT STANDING OR PONDING OF WATER IN THE STRUCTURE. THE COST OF FURNISHING AND PLACING ALL MATERIALS INCIDENTAL TO THE SHAPING IS TO BE INCLUDED IN THE BID PRICE FOR THE STRUCTURE.
5. STEPS ARE TO BE PROVIDED WHEN H IS 4'-0" OR GREATER. FOR DETAILS SEE STANDARD ST-1.
6. THIS ITEM MAY BE PRECAST OR CAST-IN-PLACE.
7. # 4 X 8" SMOOTH DOWELS AT APPROXIMATELY 12" C-C TO BE PLACED IN ALL AREAS ADJACENT TO ABUTTING CONCRETE TO PREVENT SETTLEMENT.
8. 3" DIAMETER WEEP HOLE TO BE LOCATED TO DRAIN SUBBASE MATERIAL. WEEP HOLE WITH 12"X12" PLASTIC HARDWARE CLOTH 1/4" MESH OR GALVANIZED STEEL WIRE, MINIMUM WIRE DIAMETER 0.03", NUMBER 4 MESH HARDWARE CLOTH ANCHORED FIRMLY TO THE OUTSIDE OF THE STRUCTURE.
9. ALL REINFORCING STEEL SHALL HAVE A MIN. COVER OF 2".
10. ALL REINFORCING STEEL TO BE CUT CLEAR OF ALL OPENINGS BY 2".
11. CAST-IN PLACE CONCRETE IS TO BE CLASS A3 (3000 PSI). PRECAST CONCRETE IS TO BE 4000 PSI.
12. LENGTH OF SLOT (L) WILL IN EVERY CASE, BE SHOWN ON PLANS.
13. IF INLET IS CONSTRUCTED IN MEDIAN CURB OR WITH INTEGRAL CURB, GUTTER IS TO BE OMITTED (SEE DETAIL).
14. STANDARD INLETS MAY BE CONSTRUCTED WITH CONCRETE BLOCKS IN ACCORDANCE WITH THE DETAILS SHOWN ON STANDARD DRAWING DI-MB.
15. THIS AREA MAY BE EARTHEN, IN WHICH CASE THE EXPANSION JOINTS WILL APPLY ONLY TO CURB AND GUTTER.
16. CONCRETE QUANTITIES SHOWN ARE FOR DEPTH (H) OF 6'-10" WITHOUT PIPES. THE AMOUNT DISPLACED BY PIPES MUST BE DEDUCTED TO OBTAIN TRUE QUANTITIES. FOR INLETS OF DIFFERENT DEPTHS ADD OR SUBTRACT 0.49 CUBIC YARDS OF CONCRETE FOR EACH FOOT OF DEPTH.
17. LENGTH OF ANGLE IRON AS SHOWN ON SHEET 1 OF 2 IS TO BE L +16" AT 4.10 LBS./FT..
18. * DENOTES LENGTH OF ONE (1) BAR.
19. ALL REINFORCING BARS TO BE #5.

SPECIFICATION
REFERENCE

233
302

STANDARD CURB DROP INLET

36" - 48" PIPE: MAXIMUM DEPTH (H) - 8'

VIRGINIA DEPARTMENT OF TRANSPORTATION

VDOT

ROAD AND BRIDGE STANDARDS

REVISION DATE

SHEET 2 OF 2

104.16

DI-4AA, 4BB, 4CC

NOTES

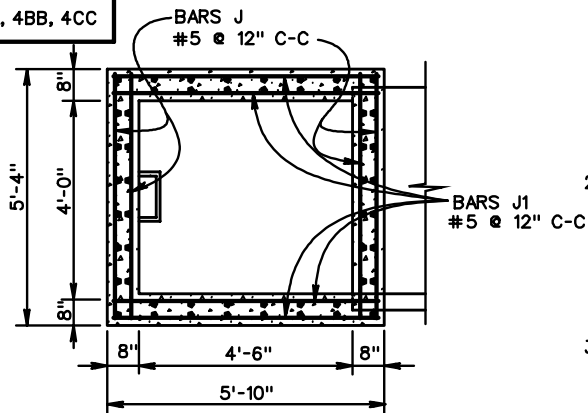

SECTION A-A

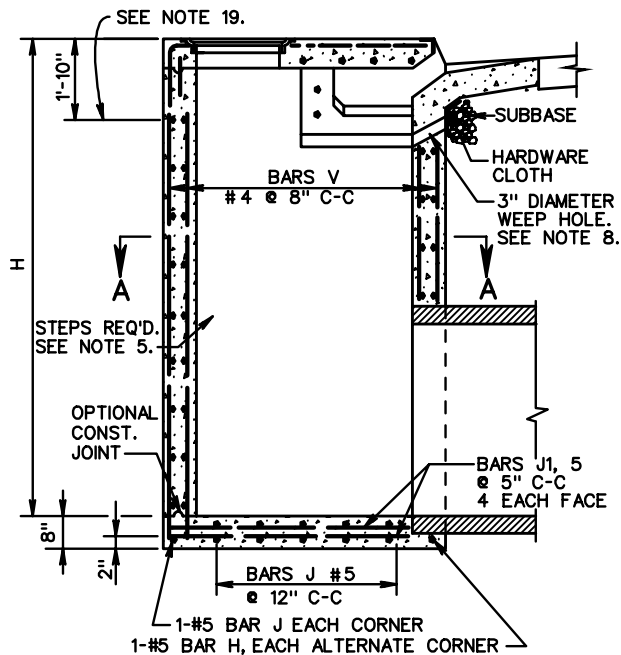

SECTION THROUGH ELEVATION

SCHEDULE OF REINFORCING STEEL SEE NOTE 17.					
BARS J		BARS J1		BARS V	
NO. REQUIRED	LENGTH	NO. REQUIRED	LENGTH	NO. REQUIRED	LENGTH
4X(H + 2)	5'-0"	4H+6	5'-6"	60	H-1'-4"

APPROXIMATE QUANTITIES FOR MINIMUM 8' DEPTH INLET			
TYPE	DIMENSION L SEE NOTE 18	REINFORCING STEEL	CONCRETE
	LIN. FT.	LBS.	CU. YDS.
4AA	4'-0"	798	5.14
4BB	6'-0"	856	5.56
4CC	8'-0"	914	5.97

INCREMENTS TO BE ADDED FOR EACH ADDITIONAL FOOT OF DEPTH (H) AND/OR SLOT LENGTH (L)			
H		L	
CONCRETE CU. YDS.	STEEL LBS.	CONCRETE CU. YDS.	STEEL LBS.
0.479	84	-	-
0.479	84	0.22	23.5
0.479	84	0.22	23.5

- DEPTH OF INLET (H) TO BE SHOWN ON PLANS. MINIMUM DEPTH (H) TO BE 8'-0". MAXIMUM DEPTH TO BE 20'-0". FOR INLETS LESS THAN 8' USE STANDARD DI-4A, 4B, AND 4C.
- THE "H" DIMENSION SHOWN ON THE STANDARDS AND SPECIFIED ON THE PLANS WILL BE MEASURED FROM THE INVERT OF THE OUTFALL PIPE TO THE TOP OF THE STRUCTURE. PLAN "H" DIMENSIONS ARE APPROXIMATE ONLY FOR ESTIMATING PURPOSES AND THE ACTUAL DIMENSIONS SHALL BE DETERMINED BY THE CONTRACTOR FROM FIELD CONDITIONS.
- WHEN SPECIFIED ON THE PLANS THE INVERT IS TO BE SHAPED IN ACCORDANCE WITH STANDARD IS-1. THE COST OF FURNISHING AND PLACING ALL MATERIALS INCIDENTAL TO THE SHAPING IS TO BE INCLUDED IN THE BID PRICE FOR THE STRUCTURE.
- IN THE EVENT THE INVERT OF THE OUTFALL PIPE IS HIGHER THAN THE BOTTOM OF THE STRUCTURE, THE INVERT OF THE STRUCTURE SHALL BE SHAPED WITH CEMENT MORTAR TO PREVENT STANDING OR PONDING OF WATER IN THE STRUCTURE. THE COST OF FURNISHING AND PLACING ALL MATERIALS INCIDENTAL TO THE SHAPING IS TO BE INCLUDED IN THE BID PRICE FOR THE STRUCTURE.
- STEPS ARE TO BE PROVIDED. FOR DETAILS SEE STANDARD ST-1.
- THIS ITEM MAY BE PRECAST OR CAST-IN-PLACE.
- #4 X 8" SMOOTH DOWELS AT APPROXIMATELY 12" C-C TO BE PLACED IN ALL AREAS ADJACENT TO ABUTTING CONCRETE TO PREVENT SETTLEMENT. IN LIEU OF DOWELS A 2" X 4" NOTCH MAY BE PROVIDED. SEE STANDARD T-DI-3, 4 FOR ALTERNATE DESIGN.
- 3" DIAMETER WEEP HOLE TO BE LOCATED TO DRAIN SUBBASE MATERIAL. WEEP HOLE WITH 12"X12" PLASTIC HARDWARE CLOTH 1/4" MESH OR GALVANIZED STEEL WIRE, MINIMUM WIRE DIAMETER 0.03", NUMBER 4 MESH HARDWARE CLOTH ANCHORED FIRMLY TO THE OUTSIDE OF THE STRUCTURE.
- ALL REINFORCING STEEL SHALL HAVE A MIN. COVER OF 2".
- ALL REINFORCING STEEL TO BE CUT CLEAR OF ALL OPENINGS BY 2".
- CAST-IN PLACE CONCRETE IS TO BE CLASS A3 (3000 PSI). PRECAST CONCRETE IS TO BE 4000 PSI.
- LENGTH OF SLOT (L) WILL, IN EVERY CASE, BE SHOWN ON PLANS.
- IF INLET IS CONSTRUCTED IN MEDIAN CURB OR WITH INTEGRAL CURB, GUTTER IS TO BE OMITTED (SEE DETAIL WITH STANDARD DI-4A, 4B, 4C).
- IF OPTIONAL CONSTRUCTION JOINT IS USED IT IS TO BE KEYPED. ALL SPLICES IN BARS V TO BE A MINIMUM OF 40 DIAMETERS (20").
- FOR PLAN VIEW OF INLET SEE STANDARD DI-4A, 4B, 4C.
- QUANTITIES SHOWN ARE FOR MINIMUM INLETS OF EACH TYPE. FOR INLETS OF GREATER DEPTH (H) OR LONGER SLOT (L) INCREMENTS SHOWN PER FOOT MUST BE ADDED. THE AMOUNT OF CONCRETE AND STEEL DISPLACED BY PIPES MUST BE DEDUCTED TO OBTAIN TRUE QUANTITIES.
- FOR NUMBER OF BARS A-H REQUIRED AND LENGTH SEE TABLE OF QUANTITIES FOR STANDARD DI-4A, 4B, 4C.
- FOR DESCRIPTION AND LOCATION OF DIMENSION L SEE SHEET STANDARD DI-4A, 4B, 4C.
- FOR ALL DETAILS, DIMENSIONS AND REINFORCING STEEL ABOVE THIS LINE, SEE STANDARD DI-4A, 4B, AND 4C.
- PROVIDE SAFETY SLABS WHEN SPECIFIED ON THE PLANS.



ROAD AND BRIDGE STANDARDS

STANDARD CURB DROP INLET

36" - 48" PIPE: DEPTH (H) 8' TO 20'

VIRGINIA DEPARTMENT OF TRANSPORTATION

SPECIFICATION
REFERENCE

233
302

SHEET 1 OF 1

REVISION DATE

104.17

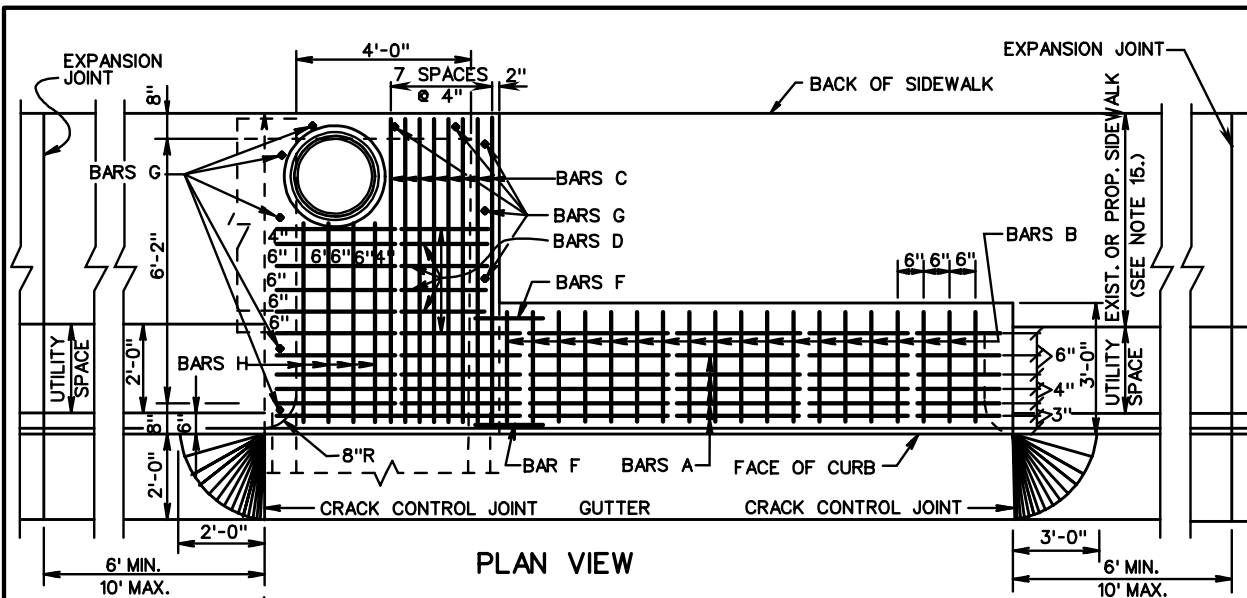

GALVANIZED PLATE TO BE BENT ON AN ANGLE OF 68° 30' & IS TO BE ANCHORED WITH 1/2" X 4" STUD SHEAR CONN. WELDED TO BENT PLATE AT 2' C-C.

TYPE A NOSE DETAIL SHALL BE USED WITH CG-3 AND CG-7 STANDARDS. TYPE B NOSE DETAIL SHALL BE USED WITH CG-2 AND CG-6 STANDARDS.

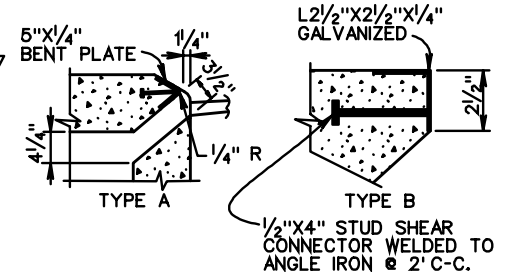

NOSE DETAILS

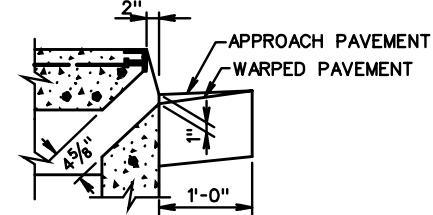

DETAIL WHEN USED ADJACENT TO CURB WITHOUT GUTTER

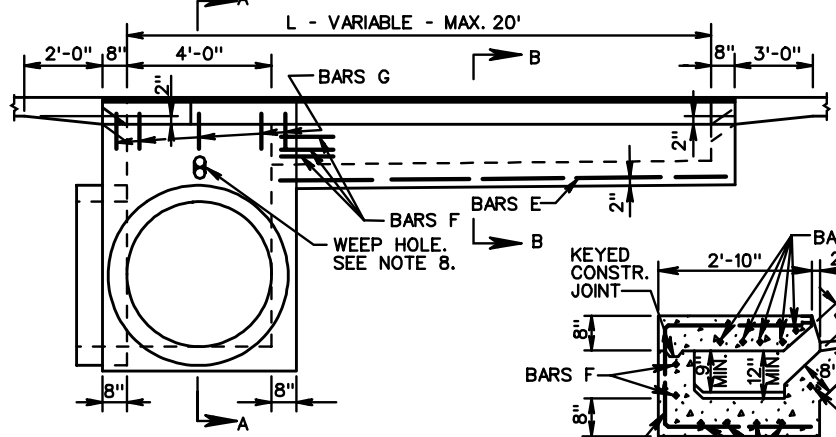

FRONT ELEVATION VIEW (GUTTER REMOVED)

SECTION B-B

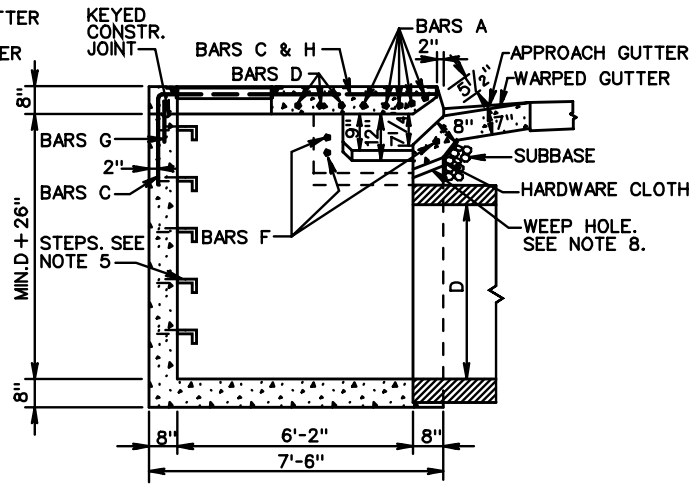

SECTION A-A

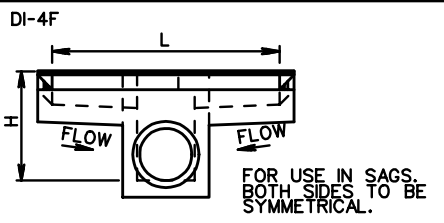
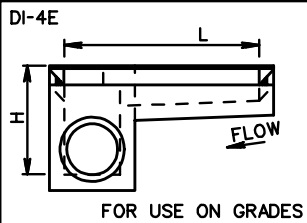
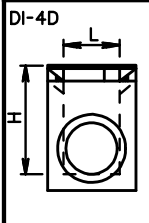

SPECIFICATION REFERENCE
233 302

STANDARD CURB DROP INLET

36" - 48" PIPE: MAXIMUM DEPTH (H) = 8' (WITH UTILITY SPACE)
 54" - 60" MAX. PIPE: MAX. (H) = 8' (WITHOUT UTILITY SPACE)
 VIRGINIA DEPARTMENT OF TRANSPORTATION

VDOT	
ROAD AND BRIDGE STANDARDS	
REVISION DATE	SHEET 1 OF 2
	104.18

TABLE OF QUANTITIES

TYPE	L	AREA OF SLOT	Concrete	REINFORCING STEEL																
				BARS A		BARS B		BARS C		BARS D		BARS E		BARS F		BARS G		BARS H		WEIGHT
				No.	Lin. Ft. ✕	No.	Lin. Ft. ✕	No.	Lin. Ft. ✕	No.	Lin. Ft. ✕	No.	Lin. Ft. ✕	No.	Lin. Ft. ✕	No.	Lin. Ft. ✕	No.	Lin. Ft. ✕	
DI-4D	4'	1.83	5.60	5	4'-8"	-	-	6	9'-2"	6	4'-8"	-	-	-	-	13	1'-0"	4	4'-6"	144
DI-4E	6'	2.75	6.02	5	6'-8"	3	6'-7" to 6'-10"	8	9'-2"	6	4'-8"	4	2'-0"	3	1'-6"	11	1'-0"	4	4'-6"	205
	8'	3.67	6.46	5	8'-8"	7	6'-7" to 6'-10"	8	9'-2"	6	4'-8"	4	4'-0"	3	1'-6"	11	1'-0"	4	4'-6"	252
	10'	4.58	6.91	5	10'-8"	11	6'-7" to 6'-10"	8	9'-2"	6	4'-8"	4	6'-0"	3	1'-6"	11	1'-0"	4	4'-6"	299
	12'	5.50	7.35	5	12'-8"	15	6'-7" to 6'-10"	8	9'-2"	6	4'-8"	4	8'-0"	3	1'-6"	11	1'-0"	4	4'-6"	345
	14'	6.42	7.80	5	14'-8"	19	6'-7" to 6'-10"	8	9'-2"	6	4'-8"	4	12'-0"	3	1'-6"	11	1'-0"	4	4'-6"	392
	16'	7.33	8.25	5	16'-8"	23	6'-7" to 6'-10"	8	9'-2"	6	4'-8"	4	10'-0"	3	1'-6"	11	1'-0"	4	4'-6"	439
	18'	8.25	8.69	5	18'-8"	27	6'-7" to 6'-10"	8	9'-2"	6	4'-8"	4	14'-0"	3	1'-6"	11	1'-0"	4	4'-6"	486
	20'	9.17	9.14	5	20'-8"	31	6'-7" to 6'-10"	8	9'-2"	6	4'-8"	4	16'-0"	3	1'-6"	11	1'-0"	4	4'-6"	532
DI-4F	8'	3.67	6.43	5	8'-8"	6	6'-7" to 6'-10"	10	9'-2"	6	4'-8"	8	2'-0"	6	1'-6"	9	1'-0"	4	4'-6"	267
	10'	4.58	6.87	5	10'-8"	10	6'-7" to 6'-10"	10	9'-2"	6	4'-8"	8	3'-0"	6	1'-6"	9	1'-0"	4	4'-6"	313
	12'	5.50	7.32	5	12'-8"	14	6'-7" to 6'-10"	10	9'-2"	6	4'-8"	8	4'-0"	6	1'-6"	9	1'-0"	4	4'-6"	360
	14'	6.42	7.76	5	14'-8"	18	6'-7" to 6'-10"	10	9'-2"	6	4'-8"	8	5'-0"	6	1'-6"	9	1'-0"	4	4'-6"	407
	16'	7.33	8.21	5	16'-8"	22	6'-7" to 6'-10"	10	9'-2"	6	4'-8"	8	6'-0"	6	1'-6"	9	1'-0"	4	4'-6"	454
	18'	8.25	8.65	5	18'-8"	26	6'-7" to 6'-10"	10	9'-2"	6	4'-8"	8	7'-0"	6	1'-6"	9	1'-0"	4	4'-6"	500
	20'	9.17	9.10	5	20'-8"	30	6'-7" to 6'-10"	10	9'-2"	6	4'-8"	8	8'-0"	6	1'-6"	9	1'-0"	4	4'-6"	547

NOTES

- DEPTH OF INLET (H) TO BE SHOWN ON PLANS.
- THE "H" DIMENSION SHOWN ON THE STANDARDS AND SPECIFIED ON THE PLANS WILL BE MEASURED FROM THE INVERT OF THE OUTFALL PIPE TO THE TOP OF THE STRUCTURE. PLAN "H" DIMENSIONS ARE APPROXIMATE ONLY FOR ESTIMATING PURPOSES AND THE ACTUAL DIMENSIONS SHALL BE DETERMINED BY THE CONTRACTOR FROM FIELD CONDITIONS.
- WHEN SPECIFIED ON THE PLANS THE INVERT IS TO BE SHAPED IN ACCORDANCE WITH STANDARD IS-1. THE COST OF FURNISHING AND PLACING ALL BE MATERIALS INCIDENTAL TO THE SHAPING IS TO INCLUDED IN THE BID PRICE FOR THE STRUCTURE.
- IN THE EVENT THE INVERT OF THE OUTFALL PIPE IS HIGHER THAN THE BOTTOM OF THE STRUCTURE, THE INVERT OF THE STRUCTURE SHALL BE SHAPED WITH CEMENT MORTAR TO PREVENT STANDING OR PONDING OF WATER IN THE STRUCTURE. THE COST OF FURNISHING AND PLACING ALL MATERIALS INCIDENTAL TO THE SHAPING IS TO BE INCLUDED IN THE BID PRICE FOR THE STRUCTURE.
- STEPS ARE TO BE PROVIDED WHEN H IS 4'-0" OR GREATER. FOR DETAILS SEE STANDARD ST-1.
- THIS ITEM MAY BE PRECAST OR CAST-IN-PLACE.
- # 4 X 8" SMOOTH DOWELS AT APPROXIMATELY 12" C-C TO BE PLACED IN ALL AREAS ADJACENT TO ABUTTING CONCRETE TO PREVENT SETTLEMENT. IN LIEU OF DOWELS A 2" X 4" NOTCH MAY BE PROVIDED. SEE STANDARD T-DI-3, 4 FOR ALTERNATE DESIGN.
- 3" DIAMETER WEEP HOLE TO BE LOCATED TO DRAIN SUBBASE MATERIAL. WEEP HOLE WITH 12"X12" PLASTIC HARDWARE CLOTH 1/4" MESH OR GALVANIZED STEEL WIRE, MINIMUM WIRE DIAMETER 0.03", NUMBER 4 MESH HARDWARE CLOTH ANCHORED FIRMLY TO THE OUTSIDE OF THE STRUCTURE.
- ALL REINFORCING STEEL SHALL HAVE A MIN. COVER OF 2".
- ALL REINFORCING STEEL TO BE CUT CLEAR OF ALL OPENINGS BY 2".
- CAST-IN PLACE CONCRETE IS TO BE CLASS A3 (3000 PSI). PRECAST CONCRETE IS TO BE 4000 PSI.
- THIS STANDARD IS INTENDED FOR USE IN CURB AND GUTTER SITUATIONS ONLY.
- IF INLET IS CONSTRUCTED IN MEDIAN CURB OR WITH INTEGRAL CURB, GUTTER IS TO BE OMITTED (SEE DETAIL).
- STANDARD INLETS MAY BE CONSTRUCTED WITH CONCRETE BLOCKS IN ACCORDANCE WITH THE DETAILS SHOWN ON STANDARD DRAWING DI-MB.
- THIS AREA MAY BE EARTHEN, IN WHICH CASE THE EXPANSION JOINTS WILL APPLY ONLY TO CURB AND GUTTER.
- CONCRETE QUANTITIES SHOWN ARE FOR DEPTH (H) OF 5'-2" WITHOUT PIPES. THE AMOUNT DISPLACED BY PIPES MUST BE DEDUCTED TO OBTAIN TRUE QUANTITIES. FOR INLETS OF DIFFERENT DEPTHS ADD OR SUBTRACT 0.28 CUBIC YARDS OF CONCRETE FOR EACH FOOT OF DEPTH.
- LENGTH OF ANGLE IRON AS SHOWN ON SHEET 1 OF 2 IS TO BE L+16" AT 4.10 LBS./FT..
- X DENOTES LENGTH OF ONE (1) BAR.
- ALL REINFORCING BARS TO BE #5.
- INLET MAY BE USED WITH LARGER LONGITUDINAL PIPES (60" MAXIMUM) PROVIDED UTILITY SPACE CLEARANCE IS NOT NEEDED, HORIZONTAL CLEARANCE BETWEEN ADJACENT PIPES IS ADEQUATE AND MINIMUM HEIGHT (H) EQUALS PIPE DIAMETER PLUS 3 FEET.



ROAD AND BRIDGE STANDARDS

STANDARD CURB DROP INLET (WITH UTILITY SPACE)

SPECIFICATION
REFERENCE

SHEET 2 OF 2

REVISION DATE

36" - 48" PIPE: MAXIMUM DEPTH (H) - 8'

233
302

104.19

VIRGINIA DEPARTMENT OF TRANSPORTATION

NOTES

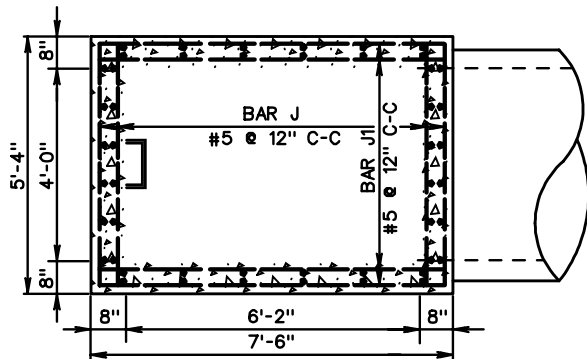

SECTION A-A

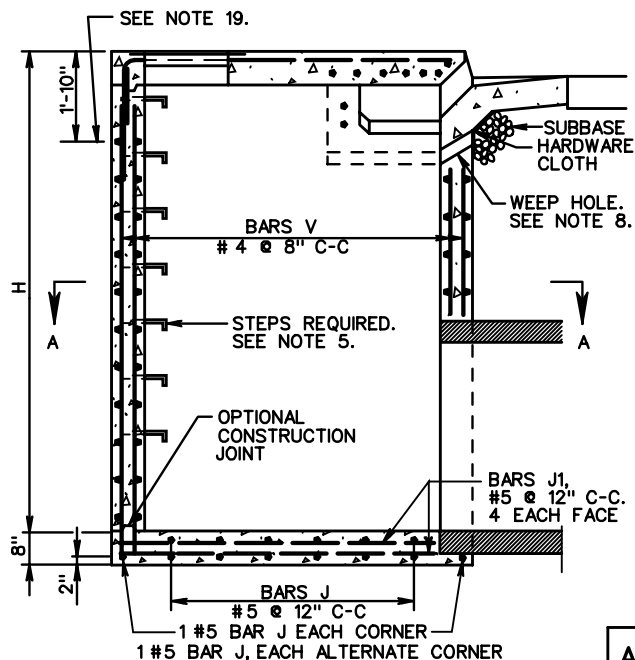

SECTION THROUGH ELEVATION

SCHEDULE OF REINFORCING STEEL (SEE NOTE 17)					
BARS J		BARS J1		BARS V	
NO. REQ'D.	LENGTH	NO. REQ'D.	LENGTH	NO. REQ'D.	LENGTH
4H + 10	5'-0"	4H + 6	7'-2"	72	H-1'-4"

APPROXIMATE QUANTITIES FOR MINIMUM 8' DEPTH INLET			
TYPE	DIMENSION L SEE NOTE 18	REINFORCING STEEL	CONC.
DI-	LIN. FT.	LBS.	CU. YDS.
4DD	4'-0"	968	6.19
4EE	6'-0"	1029	6.61
4FF	8'-0"	1091	7.02

INCREMENTS TO BE ADDED FOR EACH ADDITIONAL FOOT OF DEPTH (H) AND/OR SLOT LENGTH (L)			
H		L	
CONC. CU. YDS.	STEEL LBS.	CONC. CU. YDS.	STEEL LBS.
0.560	99	—	—
0.560	99	0.22	23.5
0.560	99	0.22	23.5

- DEPTH OF INLET (H) TO BE SHOWN ON PLANS. MINIMUM DEPTH (H) TO BE 8'-0". MAXIMUM DEPTH TO BE 16'-0". FOR INLETS LESS THAN 8' USE STANDARD DI-4D, 4E, AND 4F.
- THE "H" DIMENSION SHOWN ON THE STANDARDS AND SPECIFIED ON THE PLANS WILL BE MEASURED FROM THE INVERT OF THE OUTFALL PIPE TO THE TOP OF THE STRUCTURE. PLAN "H" DIMENSIONS ARE APPROXIMATE ONLY FOR ESTIMATING PURPOSES AND THE ACTUAL DIMENSIONS SHALL BE DETERMINED BY THE CONTRACTOR FROM FIELD CONDITIONS.
- WHEN SPECIFIED ON THE PLANS THE INVERT IS TO BE SHAPED IN ACCORDANCE WITH STANDARD IS-1. THE COST OF FURNISHING AND PLACING ALL MATERIALS INCIDENTAL TO THE SHAPING IS TO BE INCLUDED IN THE BID PRICE FOR THE STRUCTURE.
- IN THE EVENT THE INVERT OF THE OUTFALL PIPE IS HIGHER THAN THE BOTTOM OF THE STRUCTURE, THE INVERT OF THE STRUCTURE SHALL BE SHAPED WITH CEMENT MORTAR TO PREVENT STANDING OR PONDING OF WATER IN THE STRUCTURE. THE COST OF FURNISHING AND PLACING ALL MATERIALS INCIDENTAL TO THE SHAPING IS TO BE INCLUDED IN THE BID PRICE FOR THE STRUCTURE.
- STEPS ARE TO BE PROVIDED. FOR DETAILS SEE STANDARD ST-1.
- THIS ITEM MAY BE PRECAST OR CAST-IN-PLACE.
- #4 X 8" SMOOTH DOWELS AT APPROXIMATELY 12" C-C TO BE PLACED IN ALL AREAS ADJACENT TO ABUTTING CONCRETE TO PREVENT SETTLEMENT. IN LIEU OF DOWELS A 2" X 4" NOTCH MAY BE PROVIDED. SEE STANDARD T-DI-3, 4 FOR ALTERNATE DESIGN.
- 3" DIAMETER WEEP HOLE TO BE LOCATED TO DRAIN SUBBASE MATERIAL. WEEP HOLE WITH 12"X12" PLASTIC HARDWARE CLOTH 1/4" MESH OR GALVANIZED STEEL WIRE, MINIMUM WIRE DIAMETER 0.03", NUMBER 4 MESH HARDWARE CLOTH ANCHORED FIRMLY TO THE OUTSIDE OF THE STRUCTURE.
- ALL REINFORCING STEEL SHALL HAVE A MIN. COVER OF 2".
- ALL REINFORCING STEEL TO BE CUT CLEAR OF ALL OPENINGS BY 2".
- CAST-IN PLACE CONCRETE IS TO BE CLASS A3 (3000 PSI). PRECAST CONCRETE IS TO BE 4000 PSI.
- LENGTH OF SLOT (L) WILL, IN EVERY CASE, BE SHOWN ON PLANS.
- IF INLET IS CONSTRUCTED IN MEDIAN CURB OR WITH INTEGRAL CURB, GUTTER IS TO BE OMITTED (SEE DETAIL WITH STANDARD DI-4D, 4E, 4F).
- IF OPTIONAL CONSTRUCTION JOINT IS USED IT IS TO BE KEYS. ALL SPLICES IN BARS V TO BE A MINIMUM OF 40 DIAMETER (20").
- FOR PLAN VIEW OF INLET SEE STANDARD DI-4D, 4E, 4F.
- CONCRETE QUANTITIES SHOWN ARE FOR DEPTH (H) OF 5'-2" WITHOUT PIPES. THE AMOUNT DISPLACED BY PIPES MUST BE DEDUCTED TO OBTAIN TRUE QUANTITIES. FOR INLETS OF DIFFERENT DEPTHS ADD OR SUBTRACT 0.28 CUBIC YARDS OF CONCRETE FOR EACH FOOT OF DEPTH.
- FOR NUMBER OF BARS A-H REQUIRED AND LENGTH SEE TABLE OF QUANTITIES FOR STANDARD DI-4D, 4E, 4F.
- FOR DESCRIPTION AND LOCATION OF DIMENSION L SEE SHEET STANDARD DI-4D, 4E, 4F.
- FOR ALL DETAILS, DIMENSIONS AND REINFORCING STEEL ABOVE THIS LINE, SEE STANDARD DI-4D, 4E, AND 4F.
- INLET MAY BE USED WITH LARGER LONGITUDINAL PIPE (72" MAXIMUM), PROVIDED UTILITY SPACE CLEARANCE IS NOT NEEDED, HORIZONTAL CLEARANCE BETWEEN ADJACENT PIPES IS ADEQUATE AND MINIMUM HEIGHT (H) EQUALS PIPE DIAMETER PLUS 3 FEET.
- PROVIDE SAFETY SLABS WHEN SPECIFIED ON THE PLANS.

SPECIFICATION REFERENCE

233
302

STANDARD CURB DROP INLET (WITH UTILITY SPACE)

36" - 48" PIPE: DEPTH (H) 8' TO 16'

VIRGINIA DEPARTMENT OF TRANSPORTATION



ROAD AND BRIDGE STANDARDS

REVISION DATE

SHEET 1 OF 1

104.20

DI-5

NOTES

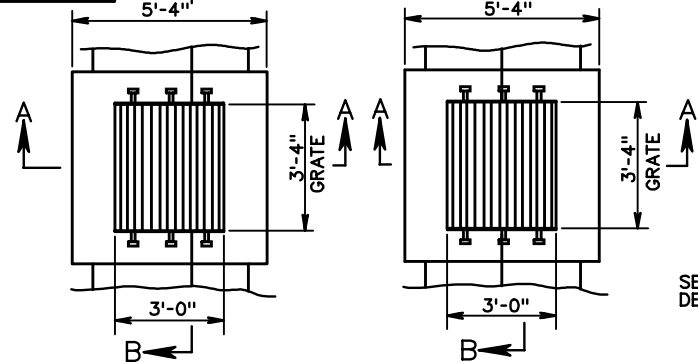

DITCH PLAN

MEDIAN PLAN

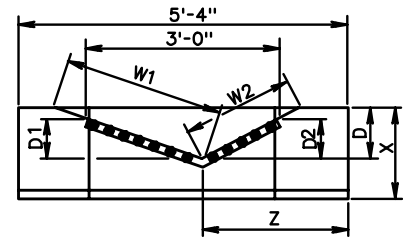

SECTION A-A

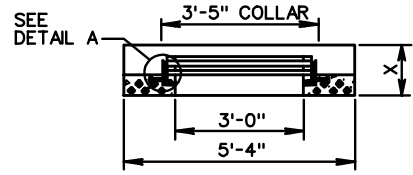

SECTION B-B

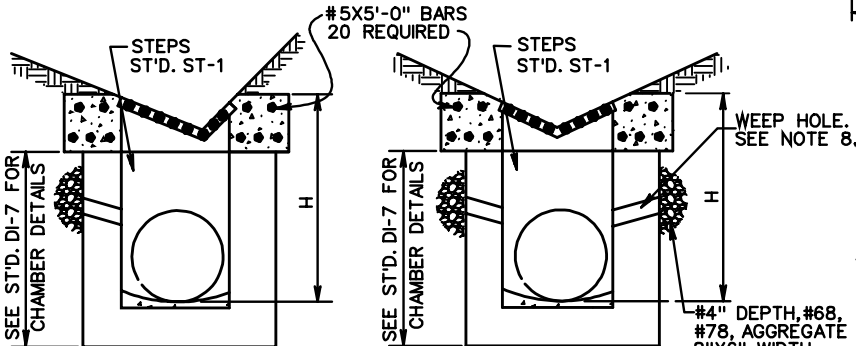

DITCH LINE SECTION

MEDIAN DITCH SECTION

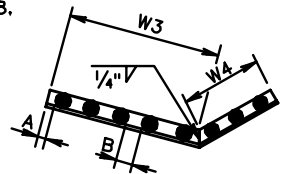

GRATE (GALVANIZED)

COLLAR DIMENSIONS TO BE 1/4" LARGER THAN GRATE DIMENSIONS W3 AND W4.

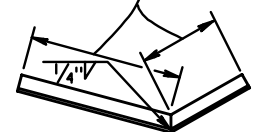

COLLAR (GALVANIZED)

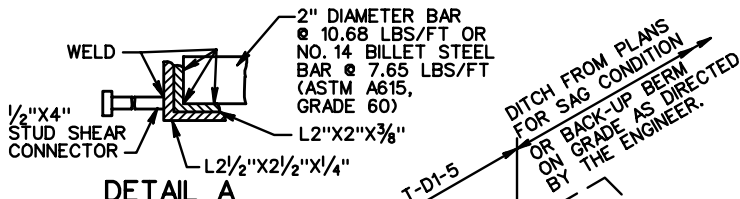

DETAIL A

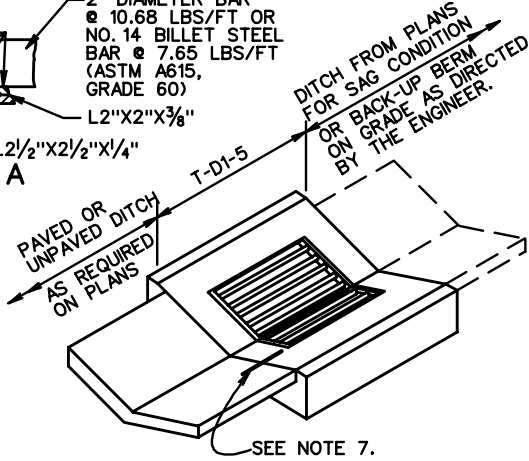

SEE NOTE 7.

1. DEPTH OF INLET (H) TO BE SHOWN ON PLANS.
2. THE "H" DIMENSION SHOWN ON THE STANDARDS AND SPECIFIED ON THE PLANS WILL BE MEASURED FROM THE INVERT OF THE OUTFALL PIPE TO THE TOP OF THE STRUCTURE. PLAN "H" DIMENSIONS ARE APPROX. ONLY FOR ESTIMATING PURPOSES AND THE ACTUAL DIMENSIONS SHALL BE DETERMINED BY THE CONTRACTOR FROM FIELD CONDITIONS.
3. WHEN SPECIFIED ON THE PLANS THE INVERT IS TO BE SHAPED IN ACCORDANCE WITH STANDARD IS-1. THE COST OF FURNISHING AND PLACING ALL MATERIALS INCIDENTAL TO THE SHAPING IS TO BE INCLUDED IN THE BID PRICE FOR THE STRUCTURE.
4. IN THE EVENT THE INVERT OF THE OUTFALL PIPE IS HIGHER THAN THE BOTTOM OF THE STRUCTURE, THE INVERT OF THE STRUCTURE SHALL BE SHAPED WITH CEMENT MORTAR TO PREVENT STANDING OR PONDING OF WATER IN THE STRUCTURE. THE COST OF FURNISHING AND PLACING ALL MATERIALS INCIDENTAL TO THE SHAPING IS TO BE INCLUDED IN THE BID PRICE FOR THE STRUCTURE.
5. STEPS ARE TO BE PROVIDED WHEN H IS 4'-0" OR GREATER. FOR DETAILS SEE STANDARD ST-1.
6. CHAMBER MAY BE CAST IN PLACE, PRECAST, BRICK OR CONCRETE BLOCK. SEE DI-7 FOR DETAILS.
7. WHERE PAVED DITCHES ARE REQUIRED, JOINTS ARE TO BE DOWELED WITH #4 X 8" SMOOTH RODS AT APPROXIMATELY 12" C-C IN ALL AREAS ADJACENT TO ABUTTING CONCRETE TO PREVENT SETTLEMENT. IN LIEU OF DOWELS A 2" X 4" NOTCH MAY BE PROVIDED. SEE ST'D T-DI-3, 4 FOR ALTERNATE DESIGN.
8. 3" DIAMETER WEEP HOLE TO BE LOCATED TO DRAIN SUBBASE MATERIAL. WEEP HOLE WITH 12"X12" PLASTIC HARDWARE CLOTH 1/4" MESH OR GALVANIZED STEEL WIRE, MINIMUM WIRE DIAMETER 0.03", NUMBER 4 MESH HARDWARE CLOTH ANCHORED FIRMLY TO THE OUTSIDE OF THE STRUCTURE.
9. ALL REINFORCING STEEL SHALL HAVE A MINIMUM COVER OF 2" AND BE CUT CLEAR OF ALL OPENINGS BY 2".
10. CAST-IN PLACE CONCRETE IS TO BE CLASS A3 (3000 PSI). PRECAST CONCRETE IS TO BE 4000 PSI.
11. PROVIDED SAFETY SLABS WHEN SPECIFIED ON THE PLANS.
12. DI-5 IS TO BE UTILIZED IN LOCATIONS NOT NORMALLY SUBJECT TO TRAFFIC.

MINIMUM H	
PIPE SIZE	H
12"	2'-9"
15"	3'-0"
18"	3'-4"
24"	3'-10"
30"	4'-5"
36"	5'-0"
42"	5'-6"

GRATE BAR SPACING CHART		
GRATE TYPE	MAXIMUM DIMENSION	
	A	B
A I	1 1/2"	3"
A III	1"	1"

ST'D PG-2A TYPE	COVER DIMENSIONS AND QUANTITIES								
	W1	W2	W3	W4	*D	D1	D2	X	Z
A1,A2,A3	3'-0 1/2"	2'-0 3/4"	2'-0 5/8"	1'-0 3/8"	6"	4"	3"	14"	2'-2"
B1,B2,B3,B4 C1,C2,C3	2'-9"	2'-9"	1'-6 9/16"	1'-6 9/16"	8"	4 1/2"	4 1/2"	16"	2'-8"
E	2'-3"	2'-3"	1'-8 1/16"	1'-8 1/16"	12"	9"	9"	19"	2'-8"

* TOLERANCE ± 1/2"



ROAD AND BRIDGE STANDARDS

STANDARD DITCH DROP INLET

SPECIFICATION REFERENCE

SHEET 1 OF 1

REVISION DATE

VIRGINIA DEPARTMENT OF TRANSPORTATION

233
302

104.21

DETAILS OF CONCRETE COVER AND GRATE

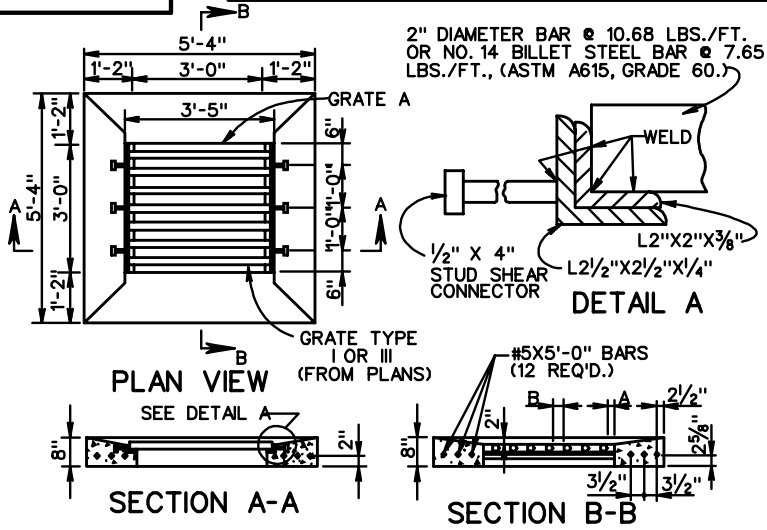

2" DIAMETER BAR @ 10.68 LBS./FT.
OR NO. 14 BILLET STEEL BAR @ 7.65
LBS./FT., (ASTM A615, GRADE 60.)

NOTES

1. GRATE A IS TO BE UTILIZED IN LOCATIONS NOT NORMALLY SUBJECT TO TRAFFIC.
2. GRATE B IS TO BE UTILIZED IN LOCATIONS NORMALLY SUBJECT TO TRAFFIC.
3. FOR DETAILS OF LOAD CARRYING GRATE (GRATE B), SEE T-DI-7, SHEET 103.0B.
4. CONCRETE COVER AND GRATE ARE TO BE FURNISHED AS A SINGLE UNIT. OUTSIDE DIMENSIONS OF GRATE TO BE 3'-4" X 2'-11 1/2" (GRATE A) OR 3'-4" X 2'-11 1/2" (GRATE B).
5. ALTERNATE METHODS OF ANCHORING ANGLE IRON WILL BE ACCEPTABLE IF APPROVED BY THE ENGINEER.
6. GRATE AND COLLAR ARE TO BE GALVANIZED.
7. CONCRETE COVER MAY BE PRECAST OR CAST IN PLACE.
8. CONCRETE TO BE CLASS A3 IF CAST IN PLACE. 4000 PSI IF PRECAST.
9. GRATE BARS TO BE PARALLEL TO DITCH FLOW.

APPROXIMATE QUANTITIES	
CONCRETE CLASS A3	REINFORCING STEEL
0.423 C. Y.	63 LBS.

GRATE TYPE	BAR SPACING CHART	
	A	B
I	1 1/2"	3"
III	1"	1"

DETAILS OF GUTTER AND METHOD OF PLACEMENT

NOTES

1. DI-7 NO GUTTERS.
DI-7A NO GUTTER IN ONE DIRECTION.
DI-7B GUTTER IN BOTH DIRECTIONS.
2. JOINTS BETWEEN GUTTERS AND CONCRETE COVER ARE TO BE DOWELED WITH #4 X 8" SMOOTH RODS @ APPROX. 12" C-C TO PREVENT SETTLEMENT. IN LIEU OF DOWELS A 2" X 4" NOTCH MAY BE PROVIDED.
SEE STANDARD T-DI-3, 4 ALTERNATE DESIGN.
3. VARIABLE 2:1 OR FLATTER.
4. DITCH GRADE MUST BE ADJUSTED TO MEET DIFFERENCE IN ELEVATION. SEE LONGITUDINAL SECTION.
5. IF DEPTH (D) BECOMES LESS THEN 4", LENGTH OF WINGS ARE TO BE EXTENDED AS DIRECTED BY THE ENGINEER.
6. CURTAIN WALL TO BE LOCATED AT THE END OF THE PAVED DITCH SECTIONS OF THE DI-7A & DI-7B THAT ARE NOT ABUTTED BY OTHER DRAINAGE.
7. IF NORMAL DITCH GRADE IS TOO FLAT TO ALLOW FOR ADJUSTED GRADE TO INLET, A SPECIAL GUTTER DETAIL WILL BE REQUIRED ON PLANS.

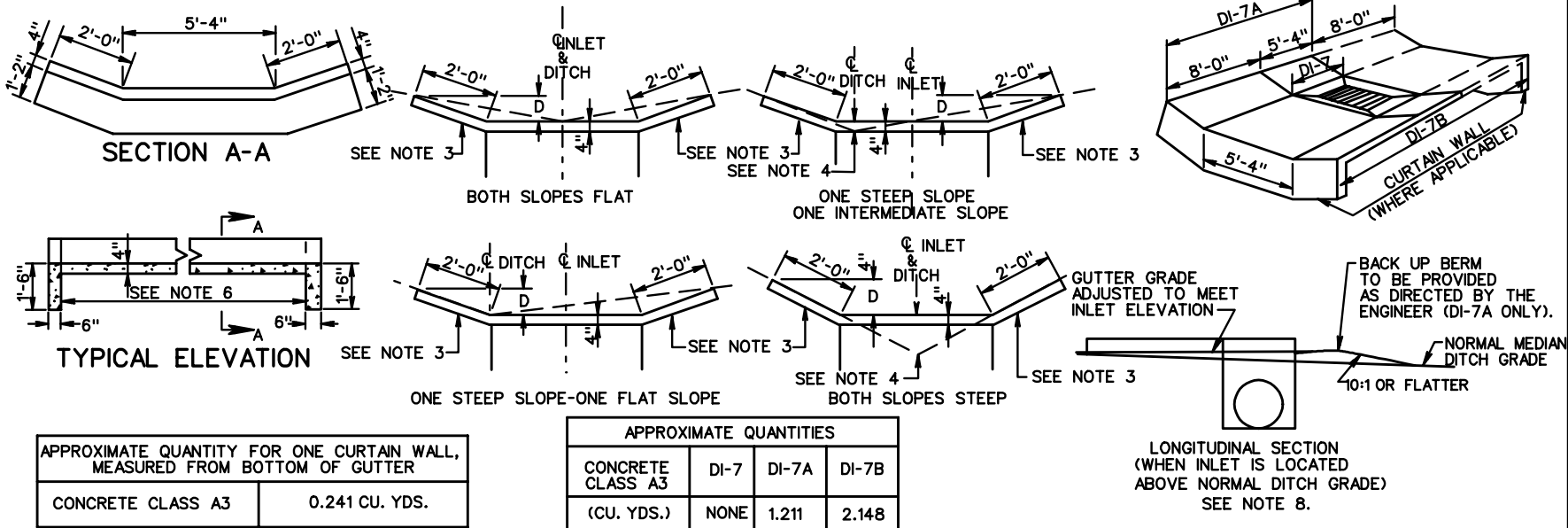

APPROXIMATE QUANTITY FOR ONE CURTAIN WALL, MEASURED FROM BOTTOM OF GUTTER	
CONCRETE CLASS A3	0.241 CU. YDS.

APPROXIMATE QUANTITIES			
CONCRETE CLASS A3 (CU. YDS.)	DI-7	DI-7A	DI-7B
	NONE	1.211	2.148

LONGITUDINAL SECTION (WHEN INLET IS LOCATED ABOVE NORMAL DITCH GRADE) SEE NOTE 8.



ROAD AND BRIDGE STANDARDS

STANDARD MEDIAN DROP INLET

SPECIFICATION REFERENCE

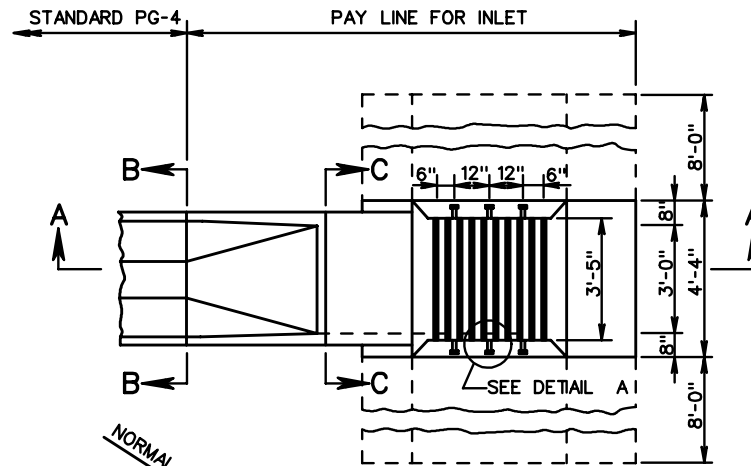

NOTES

1. APRON IS TO BE CONSTRUCTED TO A DEPTH OF 1'-0" ON BACK SLOPE SIDE OF INLET (DI-7). ON ROADWAY SIDE, THE DEPTH IS TO BE 1'-0" OR TO THE SHOULDER ELEVATION, WHICHEVER IS LESSER.
2. ALTERNATE METHODS OF ANCHORING ANGLE IRON WILL BE ACCEPTABLE IF APPROVED BY THE ENGINEER.
3. COLLAR AND GRATE ARE TO BE GALVANIZED IN ACCORDANCE WITH THE SPECIFICATIONS.
4. OUTSIDE DIMENSIONS OF GRATE ARE TO BE 3'-4" X 2'-11 3/4".
5. ALL CONCRETE IS TO BE CLASS A3.
6. NORMAL DITCH IS TO BE TRANSITIONED TO TIE SMOOTHLY INTO GUTTER. DITCH GRADE IS TO BE ADJUSTED AS NECESSARY TO MEET GRADE ELEVATION.
7. QUANTITIES SHOWN ARE BASED ON DEPTH H = 5'-0".
8. THE AMOUNT OF CONCRETE DISPLACED BY PIPES MUST BE DEDUCTED TO OBTAIN TRUE QUANTITIES. FOR EACH FOOT OF DIFFERENCE IN DEPTH H ADD OR SUBTRACT INCREMENT AS SHOWN.
9. SEE STANDARD DI-7, DI-7A AND DI-7B FOR DETAILS AND DIMENSIONS NOT SHOWN HEREON.
10. GRATE BARS ARE TO BE INSTALLED SO THEY WILL BE ALIGNED PARALLEL TO THE DITCH FLOW.

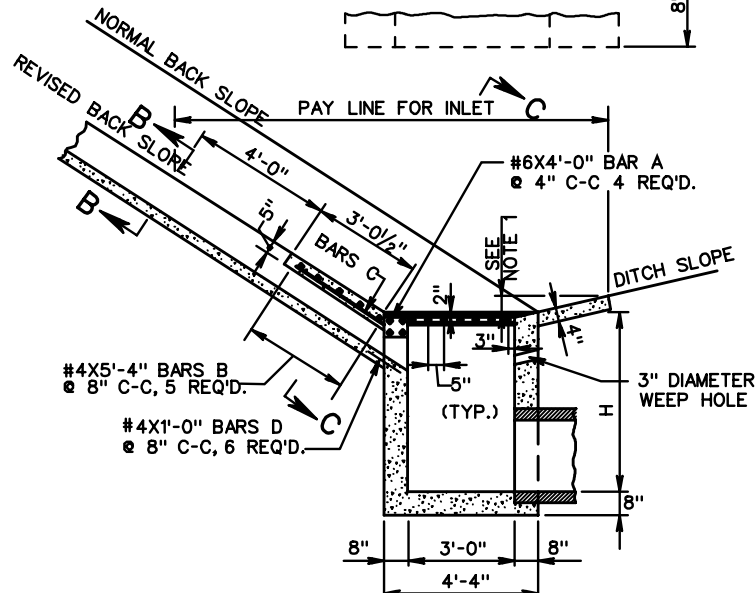

APPROXIMATE QUANTITIES	
CLASS A3 CONCRETE	REINFORCING STEEL
CU. YDS.	LBS.
4.091	60

INCREMENT PER FOOT OF DEPTH (H) = 0.362 CU. YDS.
 CONCRETE TO BE ADDED WHEN DOUBLE GUTTER IS REQ'D. = 1.112 CU. YDS.

SECTION A-A

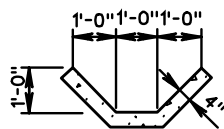

SECTION B-B

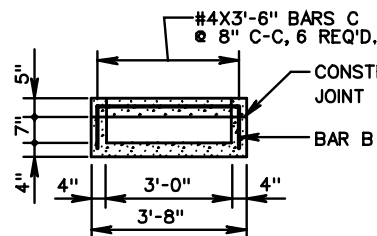

SECTION C-C

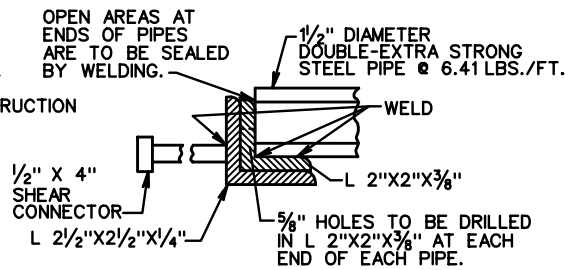

DETAIL A

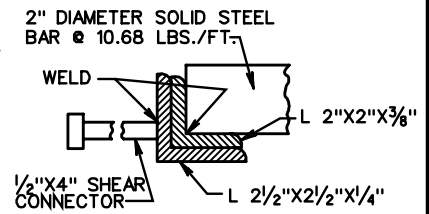

ALTERNATE DETAIL A

SPECIFICATION REFERENCE

502

STANDARD DI-7, 7A OR 7B WITH FLUME CONNECTION
 12" TO 36" PIPE

VIRGINIA DEPARTMENT OF TRANSPORTATION

VDOT

ROAD AND BRIDGE STANDARDS

REVISION DATE

SHEET 3 OF 3

104.24

NOTES

1. PRECAST PIPE PLUG SHALL BE SET IN FRESH MORTAR.
2. PRECAST PLUG SHALL CONFORM TO PIPE MANUFACTURER'S JOINT DESIGN AND SHALL HAVE A MINIMUM THICKNESS NOT LESS THAN PIPE WALL THICKNESS.
3. THIS INLET IS TO BE USED ONLY IN LOCATIONS NOT SUBJECT TO TRAFFIC.
4. FRAME IS TO BE SECURELY MORTARED TO TEE SECTION.
5. FRAME AND GRATE SHALL BE GRAY IRON, ASTM A48, CLASS 30S.
6. THE PRECAST TEE UNIT IS TO COMFORM TO THE REQUIREMENTS OF AASHTO M170 FOR 15" CLASS III REINFORCED CONCRETE PIPE.
7. IF A PRECAST PLUG IS NEEDED, THE COST OF THE PRECAST PLUG SHALL BE INCLUDED IN THE PRICE BID FOR DI-9.

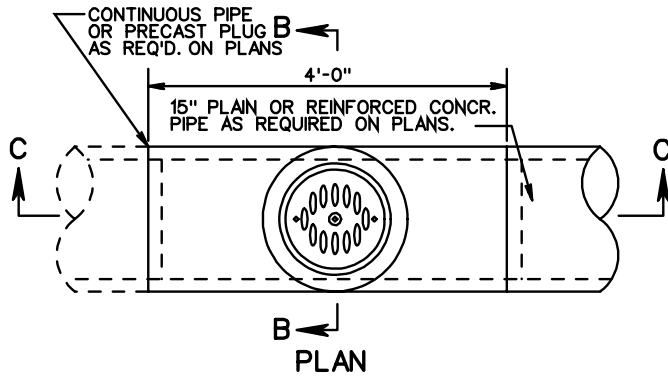

SECTION B-B

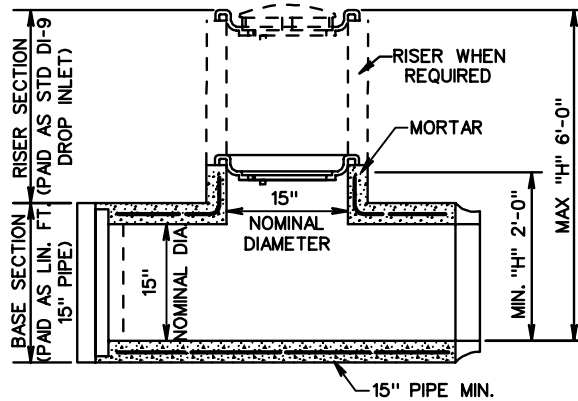
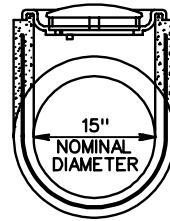

SECTION C-C

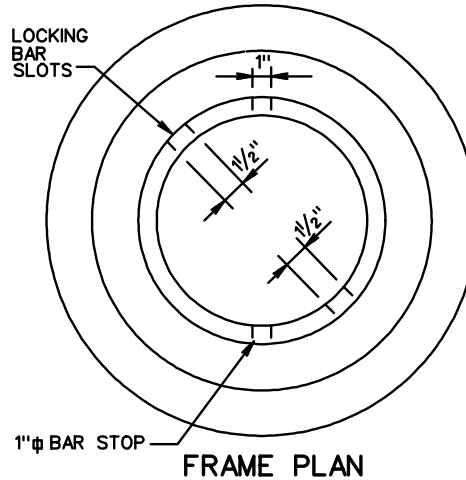

FRAME PLAN

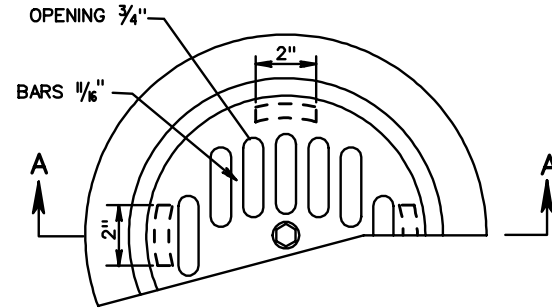

PART PLAN FRAME & GRATE

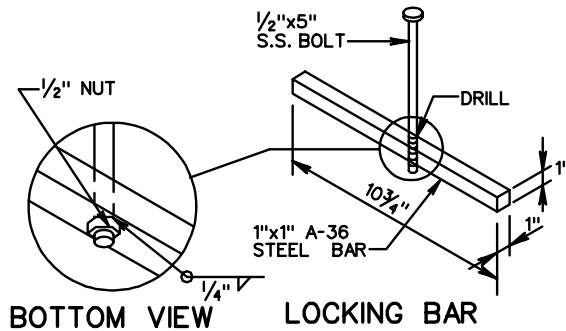

BOTTOM VIEW LOCKING BAR

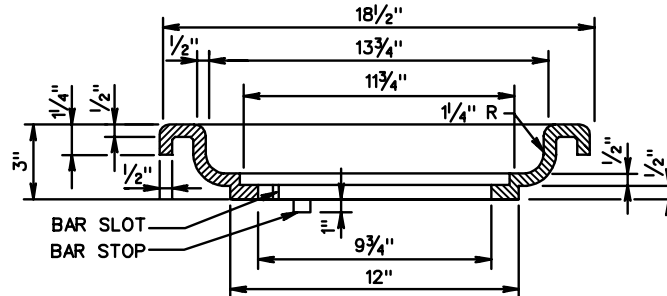

SECTION A-A FRAME

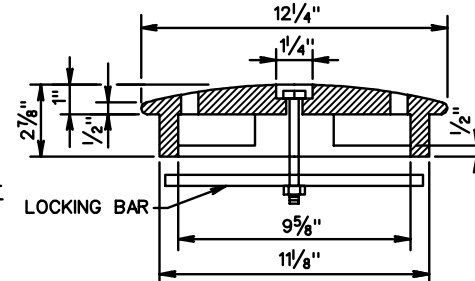

SECTION A-A GRATE



ROAD AND BRIDGE STANDARDS

15" PIPE TEE SECTION DROP INLET

SPECIFICATION REFERENCE

SHEET 1 OF 1

REVISION DATE

VIRGINIA DEPARTMENT OF TRANSPORTATION

104.25

233
302

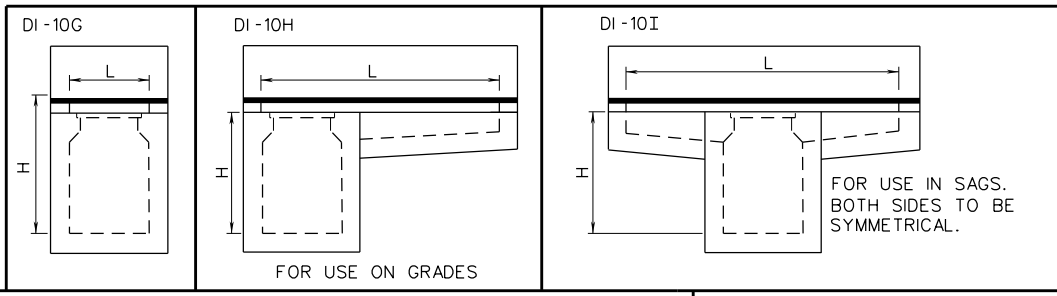
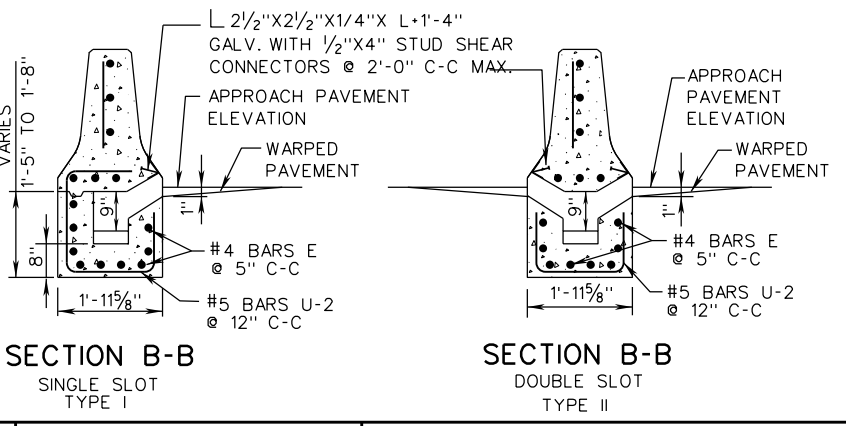
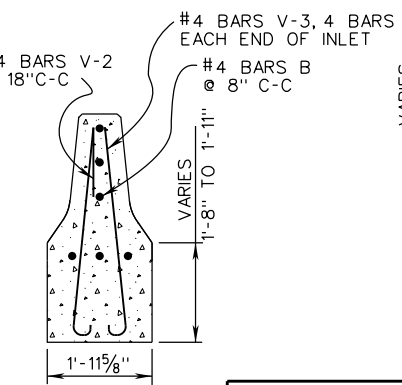
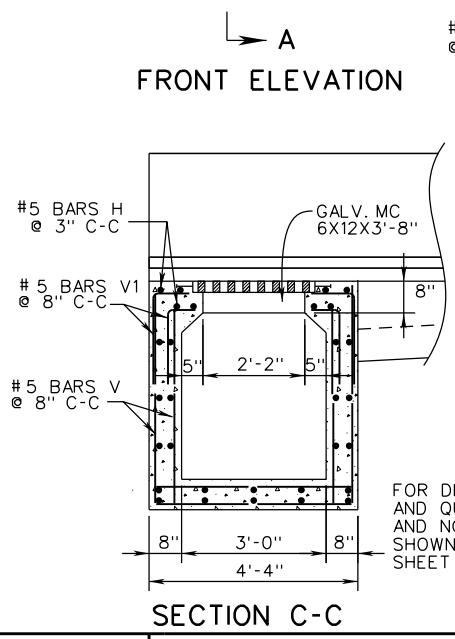
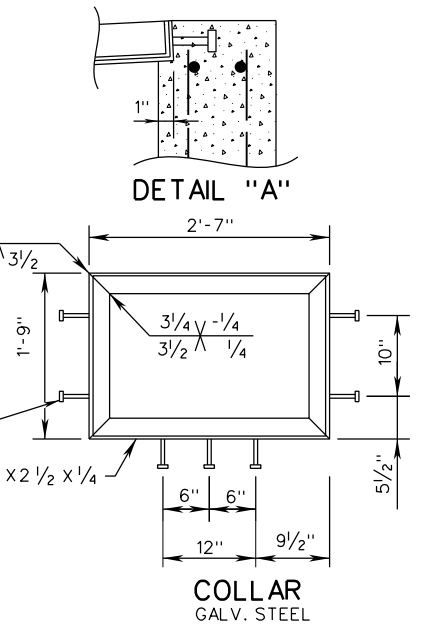
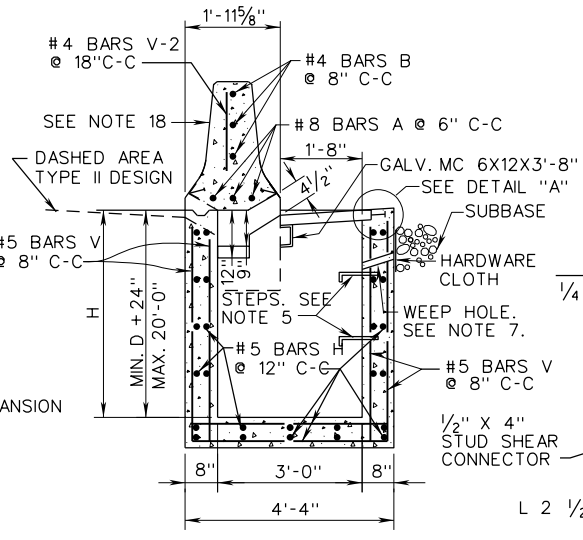
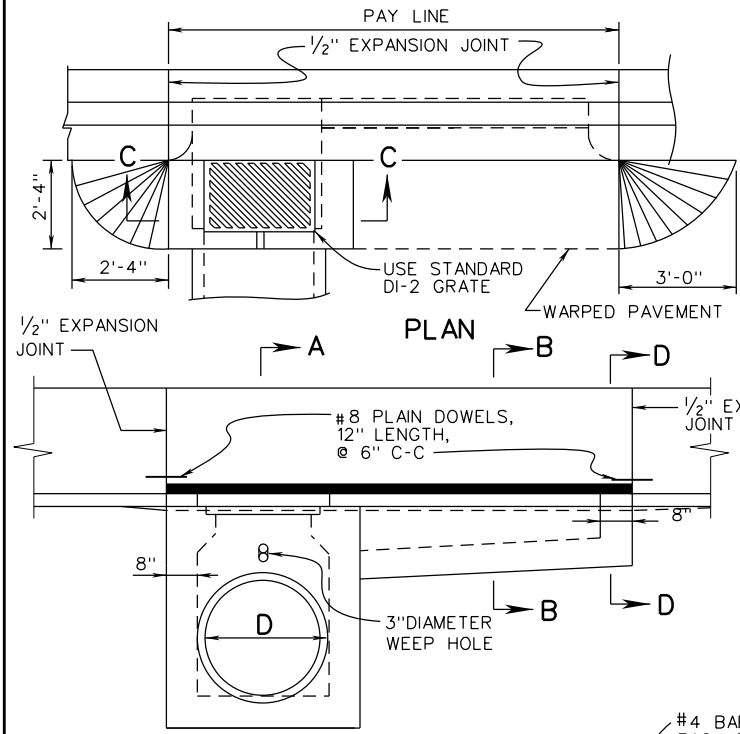

SPECIFICATION REFERENCE
233 302

CONCRETE MEDIAN BARRIER DROP INLET (WITH MB-7D)
 12" - 36" PIPE: DEPTH (H)=20'-0" MAX.
 VIRGINIA DEPARTMENT OF TRANSPORTATION

VDOT ROAD AND BRIDGE STANDARDS	
REVISION DATE 01/13	SHEET 1 OF 2 104.26

TABLE OF QUANTITIES

REINFORCING STEEL

TYPE	L	CONCRETE		BARS A	BARS B	BARS E	BARS H	BARS U-1	BARS U-2	BARS V	BARS V-1	BARS V-2	BARS V-3	TYPE I	TYPE II										
		TYPE I	TYPE II																						
		Ft.	Cu. Yd.													Cu. Yd.	No.	Ln.*Ft.	No.	Ln.*Ft.	No.	Ln.*Ft.	No.	Ln.*Ft.	No.
DI-10G	3'	2.08	2.05	3	4'-0"	3	4'-0"	-	-	38	4'-0"	-	-	-	-	48	3'-4"	12	2'-6"	3	2'-4"	8	4'-5"	426	426
	4'	2.26	2.25	3	5'-0"	3	5'-0"	8	1'-4"	38	4'-0"	2	5'-2" to 5'-8"	2	3'-1" to 3'-7"	48	3'-4"	12	2'-6"	4	2'-4"	8	4'-5"	456	451
	6'	2.65	2.63	3	7'-0"	3	7'-0"	8	3'-4"	38	4'-0"	4	5'-2" to 5'-8"	4	3'-1" to 3'-7"	48	3'-4"	12	2'-6"	5	2'-4"	8	4'-5"	499	490
	8'	3.04	3.02	3	9'-0"	3	9'-0"	8	5'-4"	38	4'-0"	6	5'-2" to 5'-8"	6	3'-1" to 3'-7"	48	3'-4"	12	2'-6"	7	2'-4"	8	4'-5"	544	531
	10'	3.43	3.40	3	11'-0"	3	11'-0"	8	7'-4"	38	4'-0"	8	5'-2" to 5'-8"	8	3'-1" to 3'-7"	48	3'-4"	12	2'-6"	8	2'-4"	8	4'-5"	588	571
DI-10H	12'	3.82	3.78	3	13'-0"	3	13'-0"	8	9'-4"	38	4'-0"	10	5'-2" to 5'-8"	10	3'-1" to 3'-7"	48	3'-4"	12	2'-6"	9	2'-4"	8	4'-5"	631	610
	14'	4.21	4.16	3	15'-0"	3	15'-0"	8	11'-4"	38	4'-0"	12	5'-2" to 5'-8"	12	3'-1" to 3'-7"	48	3'-4"	12	2'-6"	11	2'-4"	8	4'-5"	677	650
	16'	4.60	4.54	3	17'-0"	3	17'-0"	8	13'-4"	38	4'-0"	14	5'-2" to 5'-8"	14	3'-1" to 3'-7"	48	3'-4"	12	2'-6"	12	2'-4"	8	4'-5"	720	690
	18'	5.00	4.94	3	19'-0"	3	19'-0"	8	15'-4"	38	4'-0"	16	5'-2" to 5'-8"	16	3'-1" to 3'-7"	48	3'-4"	12	2'-6"	13	2'-4"	8	4'-5"	764	729
	20'	5.39	5.32	3	21'-0"	3	21'-0"	8	17'-4"	38	4'-0"	18	5'-2" to 5'-8"	18	3'-1" to 3'-7"	48	3'-4"	12	2'-6"	15	2'-4"	8	4'-5"	809	770
	6'	2.65	2.63	3	7'-0"	3	7'-0"	16	2'-0"	38	4'-0"	6	5'-2" to 5'-8"	6	3'-1" to 3'-7"	48	3'-4"	12	2'-6"	5	2'-4"	8	4'-5"	514	501
	8'	3.04	3.02	3	9'-0"	3	9'-0"	16	3'-0"	38	4'-0"	8	5'-2" to 5'-8"	8	3'-1" to 3'-7"	48	3'-4"	12	2'-6"	7	2'-4"	8	4'-5"	559	542
DI-10 I	10'	3.43	3.40	3	11'-0"	3	11'-0"	16	4'-0"	38	4'-0"	10	5'-2" to 5'-8"	10	3'-1" to 3'-7"	48	3'-4"	12	2'-6"	8	2'-4"	8	4'-5"	603	581
	12'	3.82	3.78	3	13'-0"	3	13'-0"	16	5'-0"	38	4'-0"	12	5'-2" to 5'-8"	12	3'-1" to 3'-7"	48	3'-4"	12	2'-6"	9	2'-4"	8	4'-5"	646	620
	14'	4.21	4.16	3	15'-0"	3	15'-0"	16	6'-0"	38	4'-0"	14	5'-2" to 5'-8"	14	3'-1" to 3'-7"	48	3'-4"	12	2'-6"	11	2'-4"	8	4'-5"	691	661
	16'	4.60	4.54	3	17'-0"	3	17'-0"	16	7'-0"	38	4'-0"	16	5'-2" to 5'-8"	16	3'-1" to 3'-7"	48	3'-4"	12	2'-6"	12	2'-4"	8	4'-5"	735	700
	18'	5.00	4.94	3	19'-0"	3	19'-0"	16	8'-0"	38	4'-0"	18	5'-2" to 5'-8"	18	3'-1" to 3'-7"	48	3'-4"	12	2'-6"	13	2'-4"	8	4'-5"	778	739
	20'	5.39	5.32	3	21'-0"	3	21'-0"	16	9'-0"	38	4'-0"	20	5'-2" to 5'-8"	20	3'-1" to 3'-7"	48	3'-4"	12	2'-6"	15	2'-4"	8	4'-5"	824	780

NOTES

1. DEPTH OF INLET (H) TO BE SHOWN ON PLANS.
2. THE "H" DIMENSION SHOWN ON THE STANDARDS AND SPECIFIED ON THE PLANS WILL BE MEASURED FROM THE INVERT OF THE OUTFALL PIPE TO THE TOP OF THE STRUCTURE. PLAN "H" DIMENSIONS ARE APPROXIMATE ONLY FOR ESTIMATING PURPOSES AND THE ACTUAL DIMENSIONS SHALL BE DETERMINED BY THE CONTRACTOR FROM FIELD CONDITIONS.
3. WHEN SPECIFIED ON THE PLANS THE INVERT IS TO BE SHAPED IN ACCORDANCE WITH STANDARD IS-1. THE COST OF FURNISHING AND PLACING ALL MATERIALS INCIDENTAL TO THE SHAPING IS TO BE INCLUDED IN THE BID PRICE FOR STRUCTURE.
4. IN THE EVENT THE INVERT OF THE OUTFALL PIPE IS HIGHER THAN THE BOTTOM OF THE STRUCTURE, THE INVERT OF THE STRUCTURE SHALL BE SHAPED WITH CEMENT MORTAR TO PREVENT STANDING OR PONDING OF WATER IN THE STRUCTURE. THE COST OF FURNISHING AND PLACING ALL MATERIALS INCIDENTAL TO THE SHAPING IS TO BE INCLUDED IN THE BID PRICE FOR THE STRUCTURE.
5. STEPS ARE TO BE PROVIDED WHEN H IS 4'-0" OR GREATER. FOR DETAILS SEE STANDARD ST-1.
6. THIS ITEM MAY BE PRECAST OR CAST-IN-PLACE.
7. 3" DIAMETER WEEP HOLE TO BE LOCATED TO DRAIN SUBBASE MATERIAL. WEEP HOLE WITH 12"X12" PLASTIC HARDWARE CLOTH 1/4" MESH OR GALVANIZED STEEL WIRE, MINIMUM WIRE DIAMETER 0.03", NUMBER 4 MESH HARDWARE CLOTH ANCHORED FIRMLY TO THE OUTSIDE OF THE STRUCTURE.
8. ALL REINFORCING STEEL SHALL HAVE A MIN. COVER OF 2".
9. ALL REINFORCING STEEL TO BE CUT CLEAR OF ALL OPENINGS BY 2".
10. CAST-IN PLACE CONCRETE IS TO BE CLASS A3 (3000 PSI). PRECAST CONCRETE IS TO BE 4000 PSI.
11. LENGTH OF SLOT (L) WILL, IN EVERY CASE, BE SHOWN ON PLANS.
12. CONCRETE QUANTITIES SHOWN ARE FOR DEPTH (H) OF 3'-0" WITHOUT PIPES. THE AMOUNT DISPLACED BY PIPES MUST BE DEDUCTED TO OBTAIN TRUE QUANTITIES. FOR INLETS OF DIFFERENT DEPTHS ADD OR SUBTRACT 0.36 CUBIC YARDS OF CONCRETE FOR EACH FOOT OF DEPTH. AND 84 LBS. OF REINFORCING STEEL.
13. LENGTH OF ANGLE IRON AS SHOWN ON SHEET 1 OF 2 IS TO BE L +16" AT 4.10 LBS./FT..
14. * DENOTES LENGTH OF ONE (1) BAR.
15. GRATE TO BE INSTALLED SO SLOTS WILL DIRECT WATER TOWARD THE INLET THROAT. GRATE MUST BE REVERSIBLE (RIGHT HAND GRATE IS SHOWN).
16. PROVIDE SAFETY SLABS WHEN SPECIFIED ON PLANS.
17. FOR DETAILS AND DIMENSIONS NOT SHOWN FOR MEDIAN BARRIER SEE STANDARD MB-7D.
18. QUANTITIES INCLUDE MB-7D.



ROAD AND BRIDGE STANDARDS

CONCRETE MEDIAN BARRIER DROP INLET (WITH MB-7D)

SPECIFICATION
REFERENCE

SHEET 2 OF 2

REVISION DATE

12" - 36" PIPE: DEPTH (H)-20'-0" MAX.

233
302

104.27

VIRGINIA DEPARTMENT OF TRANSPORTATION

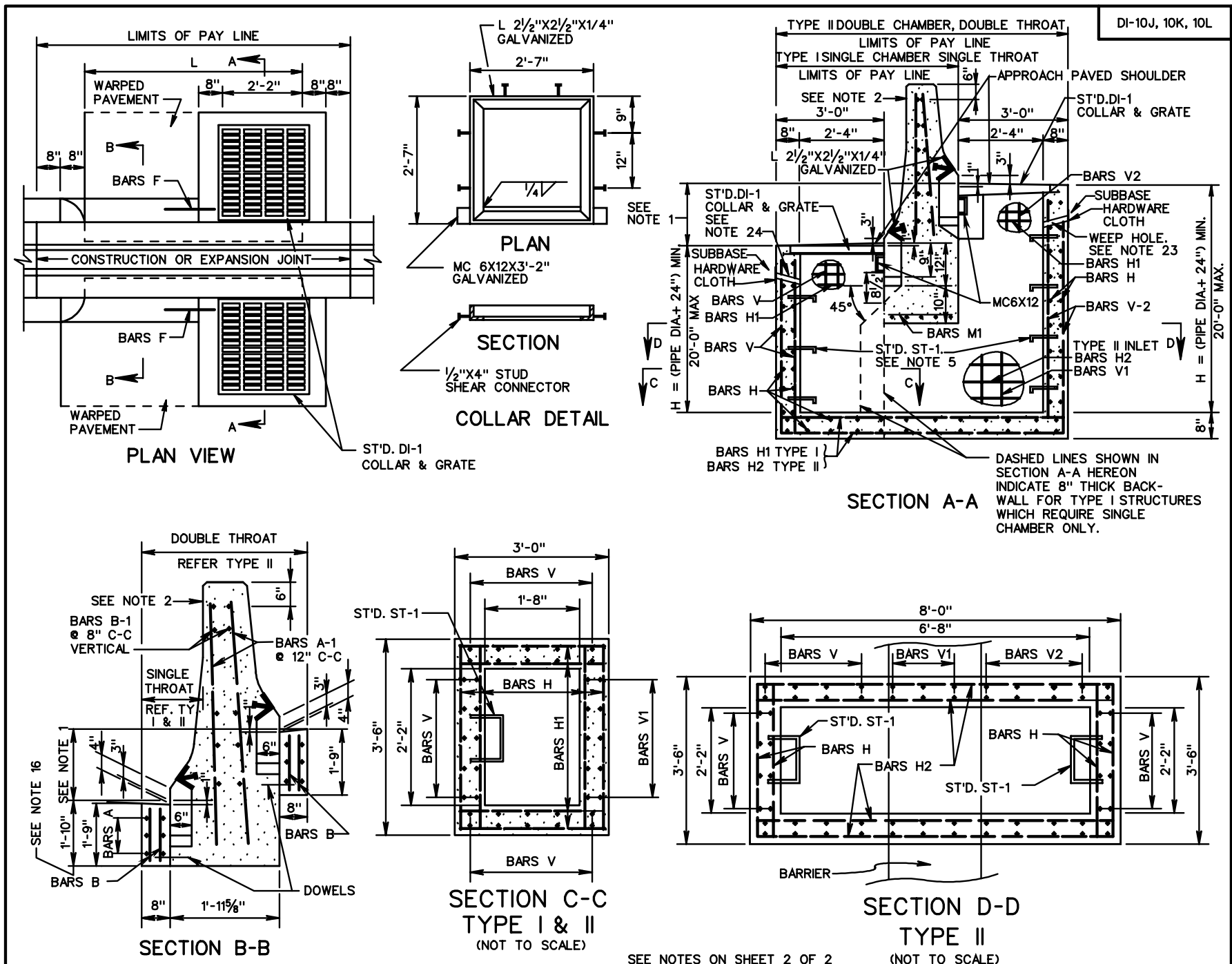

DI-10J, 10K, 10L

SECTION A-A
 DASHED LINES SHOWN IN SECTION A-A HEREON INDICATE 8" THICK BACKWALL FOR TYPE I STRUCTURES WHICH REQUIRE SINGLE CHAMBER ONLY.

SEE NOTES ON SHEET 2 OF 2 (NOT TO SCALE)

SPECIFICATION REFERENCE 233 302	<h2 style="margin: 0;">CONCRETE MEDIAN BARRIER DROP INLET (WITH MB-8A)</h2> <p style="margin: 0;">12" - 24" PIPE: DEPTH (H) - 20' MAX</p> <p style="margin: 0;">VIRGINIA DEPARTMENT OF TRANSPORTATION</p>	VDOT ROAD AND BRIDGE STANDARDS REVISION DATE SHEET 1 OF 2 104.28
---	---	---

TYPE I & III INLET

REINFORCING STEEL				
MARK	SIZE	NO.	LENGTH	SPACE
A SEE NOTE 9	#4	6 SEE NOTE 7	L - 2'-6" SEE NOTE 8	AS SHOWN
A-1 SEE NOTE 11	#4	(2xL)+2	4'-0"	12
B SEE NOTE 9	#3	2x(L-4)	1'-1"	12
B-1 SEE NOTE 11	#4	9	L + (2'-4")	8
DOWELS	#4	SEE NOTE 6	1'-0"	6
F SEE NOTE 9	#5	3 SEE NOTE 10	1'-6"	6
H	#5	(4xH) + 10	3'-2"	12
H1	#5	(4xH) + 8	2'-8"	10

TYPE - II INLET

REINFORCING STEEL				
MARK	SIZE	NO.	LENGTH	SPA.
A-1	#4	(2xL) 2	4'-0"	12"
B-1	#4	9	L+(2'-4")	8"
H-2	#5	16 SEE NOTE 12	7'-8"	10"
V-1	#4	12	H - (1'-2")	8"
V-2	#4	30	LENGTH = H	8"
A SEE NOTE 15	#4	12 SEE NOTE 14	L - (2'-6") SEE NOTE 8	AS SHOWN
B SEE NOTE 15	#3	4(L-4)	1'-1"	12"
DOWELS	#4	DOUBLE NO. SHOWN FOR TYPE I	1'-0"	6"
F SEE NOTE 15	#5	6 SEE NOTE 13	1-6"	6"
H	#5	(4 + H) + 8	3'-2"	12"
H-1	#5	(4 + H) + 16	2'-8"	10"
V	#4	30	LENGTH = H	8"
M-1	#5	5	3'-2"	5"
M	#4	4	1'-8"	12"

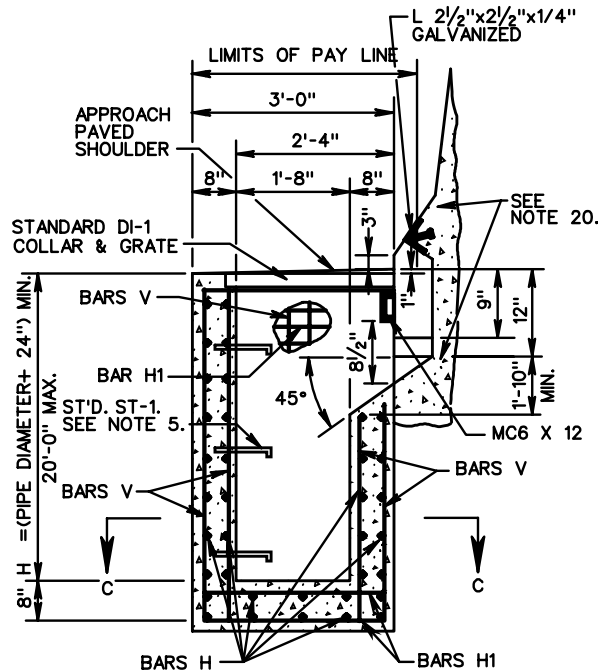

FOR USE ADJACENT TO WALL OR BARRIER WITH SAFETY SHAPE (TYPE III)

- TYPE I DENOTES INLET WITH SINGLE THROAT AND CHAMBER
TYPE II DENOTES INLET WITH DOUBLE THROAT AND CHAMBER.
TYPE III DENOTES INLET WITH SINGLE THROAT AND CHAMBER ADJACENT TO WALL OR BARRIER.
- MAXIMUM PIPE SIZE IS 24" DIAMETER.
- 3" DIAMETER WEEP HOLE TO BE LOCATED TO DRAIN SUBBASE MATERIAL. WEEP HOLE WITH 12" X 12" PLASTIC HARDWARE CLOTH 1/4" MESH OR GALV. STEEL WIRE, MIN. WIRE DIAMETER 0.03", #4 MESH HARDWARE CLOTH ANCHORED FIRMLY TO OUTSIDE OF THE STRUCTURE.
- PROVIDE SAFETY SLABS WHEN SPECIFIED ON THE PLANS.
- WHEN SPECIFIED ON THE PLANS, THE INVERT IS TO BE SHAPED IN ACCORDANCE WITH THE STANDARD IS-1. THE COST OF FURNISHING AND PLACING ALL MATERIALS INCIDENTAL TO THE SHAPING IS TO BE INCLUDED IN THE BID PRICE FOR THE STRUCTURE.

NOTES

- VARIABLES GREATER THAN:
0' TO 18" MAX. TYPE II CHAMBER.
4" TO 3' MAX. TYPE I CHAMBER.
- FOR DETAILS AND DIMENSIONS NOT SHOWN FOR MEDIAN BARRIER, SEE STANDARD MB-8A.
- GALVANIZED MC-6 X 12 IS TO BE WELDED UNDER THE COLLAR AND EXTENDED INTO SIDEWALLS TO WITHIN 2" OF OUTSIDE FACE.
- ALL REINFORCING BARS ARE TO BE GRADE 60 STEEL WITH MIN. OF 1/2" CONCRETE COVER. ANY BAR IN CONFLICT WITH PIPE SHELL AND/OR TOP SLAB OPENING ARE TO BE FIELD CUT TO PROVIDE THE REQUIRED COVER.
- DO NOT LOCATE STANDARD ST-1 STEPS ON CHAMBER WALLS THAT HAVE PIPES WHEN POSSIBLE.
- 8 DOWELS REQUIRED FOR DI-10L, MIN. L = 7'-0". ADD 2 DOWELS FOR EACH ADDITIONAL FOOT.
4 DOWELS REQUIRED FOR DI-10K, MIN. L = 4'-0". ADD 2 DOWELS FOR EACH ADDITIONAL FOOT.
- 12 BARS A REQUIRED FOR DI-10L.
- LENGTH OF BARS A, DI-10L = $\frac{L - (2'-6")}{2}$
- DO NOT USE WITH DI-10J.
- USE 6 BARS F FOR DI-10L TYPE I
- DO NOT USE WITH TYPE III.
- ADD 4 ADDITIONAL BARS FOR EACH EXTRA FOOT OF DEPTH.
- USE 12 BARS F FOR DI-10L TYPE II.
- 24 BARS A ARE REQUIRED FOR DI-10L.
- DO NOT USE WITH DI-10J.
- A MINIMUM 22" FOOTING DEPTH IS REQUIRED FOR FORMING THE INLET SLOT. SEE PLANS FOR LENGTH "L".
- REFER TO PLANS FOR STRUCTURE LOCATIONS, DATA AND DIMENSIONS.
- REFER TO PLANS FOR LOCATIONS OF PIPES AND INVERTS.
- FOR TYPE III, COST OF ACCOMMODATION OF INLET THROAT IS TO BE INCLUDED IN COST OF WALL BARRIER.
- FOR TYPE III, SEE WALL PLANS FOR WALL FOOTING DETAILS.

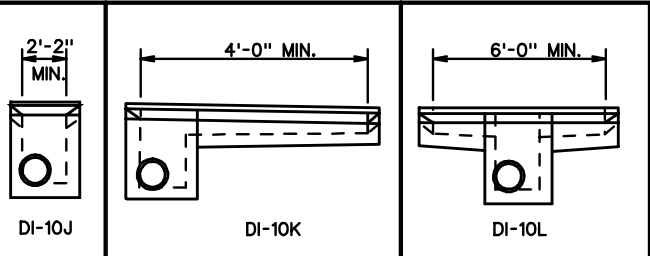

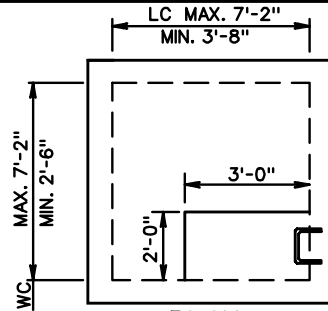

PLAN
(SLOT REMOVED)

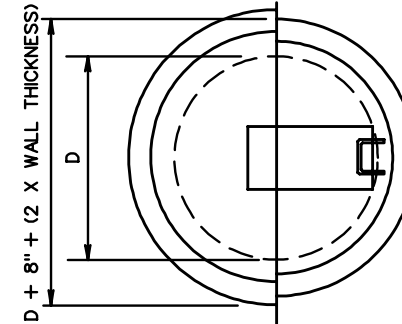

PLAN
(SLOT REMOVED)

X DIM.	DEPTH
8"	0' TO 10'
12"	10' TO 16'
16"	16' TO 25'

Y DIM.	DEPTH
5"	0' TO 12'
10"	12' TO 25'

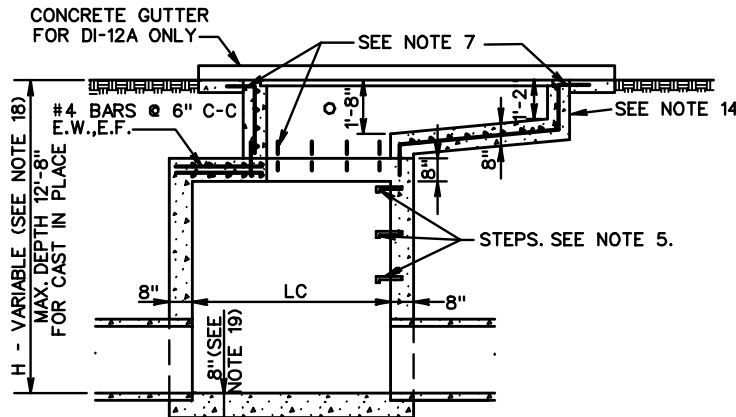

SECTION
(CAST IN PLACE)

MAXIMUM DEPTH: UNLIMITED, 60" MINIMUM DIAMETER.

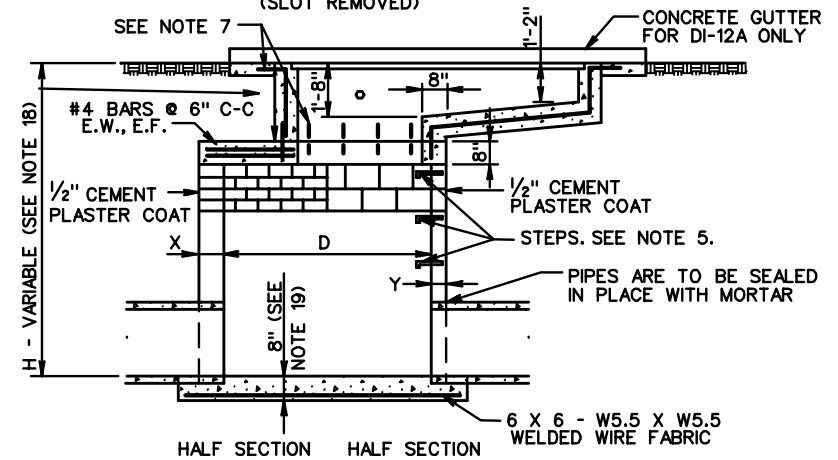

BRICK CONCRETE BLOCK

NOTES

- USE OF INLET RESTRICTED TO NON-VEHICULAR LOCATIONS.
- DEPTH OF INLET (H) AND LENGTH (L) TO BE SHOWN ON PLANS.
- THE "H" DIMENSION SHOWN ON THE STANDARDS AND SPECIFIED ON THE PLANS WILL BE MEASURED FROM THE INVERT OF THE OUTFALL PIPE TO THE TOP OF THE STRUCTURE.
- WHEN SPECIFIED ON THE PLANS THE INVERT IS TO BE SHAPED IN ACCORDANCE WITH STANDARD IS-1. THE COST OF FURNISHING AND PLACING ALL MATERIALS INCIDENTAL TO THE SHAPING IS TO BE INCLUDED IN THE BID PRICE FOR THE STRUCTURE.
- IN THE EVENT THE INVERT OF THE OUTFALL PIPE IS HIGHER THAN THE BOTTOM OF THE STRUCTURE, THE INVERT OF THE STRUCTURE SHALL BE SHAPED WITH CEMENT MORTAR TO PREVENT STANDING OR PONDING OF WATER IN THE STRUCTURE. THE COST OF FURNISHING AND PLACING ALL MATERIALS INCIDENTAL TO THE SHAPING IS TO BE INCLUDED IN THE BID PRICE FOR THE STRUCTURE.
- STEPS ARE TO BE PROVIDED WHEN H IS 4'-0" OR GREATER. FOR DETAILS SEE STANDARD ST-1.
- CHAMBER MAY BE PRECAST. SEE STANDARD 103.10 FOR DETAILS.
- # 4 DOWELS 12" LONG SPACED AT 12" C-C ALL SIDES.
- FOOTING MAY BE ROUND OR SQUARE IN SHAPE. KEY IS TO BE 1" DEEP X WALL THICKNESS + 1".
- ALL REINFORCING STEEL SHALL HAVE A MIN. COVER OF 2".
- ALL REINFORCING STEEL TO BE CUT CLEAR OF ALL OPENINGS BY 2".
- CAST-IN PLACE CONCRETE IS TO BE CLASS A3 (3000 PSI). PRECAST CONCRETE IS TO BE 4000 PSI.
- ALL REINFORCING BARS TO BE #4.
- GRATE BARS TO BE INSTALLED SO THEY WILL BE ALIGNED PARALLEL TO DITCH FLOW.
- FOR DETAILS OF CONCRETE SLOT, COLLAR AND GRATE, AND METHOD OF PLACING APPROACH GUTTER SEE SHEET 2 OF 3.
- PAVED DITCHES ARE TO BE TRANSITIONED TO MEET INLET GUTTER AS SHOWN IN ST'D. PG-2A.
- QUANTITIES SHOWN ARE FOR INLETS WITHOUT PIPES. PIPE DISPLACEMENTS MUST BE DEDUCTED TO OBTAIN TRUE QUANTITIES. SEE SHEET 3 OF 3 FOR QUANTITIES.
- PROVIDE SAFETY SLABS WHEN SPECIFIED ON THE PLANS.
- SEE TABULATION CHART ON SHEET 3 OF 3 FOR MINIMUM DEPTH (H).
- 10" THICK SLAB FOR PIPE SIZES 60" TO 72" IN DIAMETER.
- THE TYPE OF INLET DETAILED HEREON TO BE CONSTRUCTED WILL BE AT THE OPTION OF THE CONTRACTOR.
- DI-12 NO GUTTER.
DI-12A PERIPHERAL GUTTER.

SPECIFICATION REFERENCE

233
302

**MULTIGRATE DROP INLET
FOR PIPE SIZES 12" TO 72"**

VIRGINIA DEPARTMENT OF TRANSPORTATION



ROAD AND BRIDGE STANDARDS

REVISION DATE

SHEET 1 OF 3

104.30

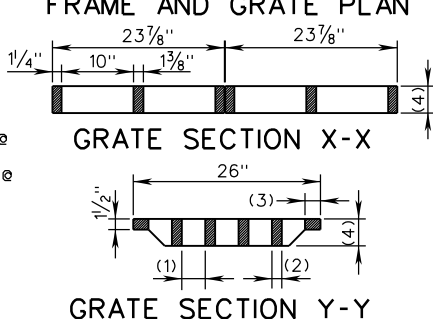
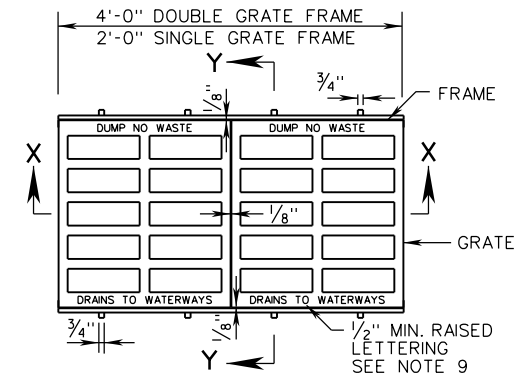
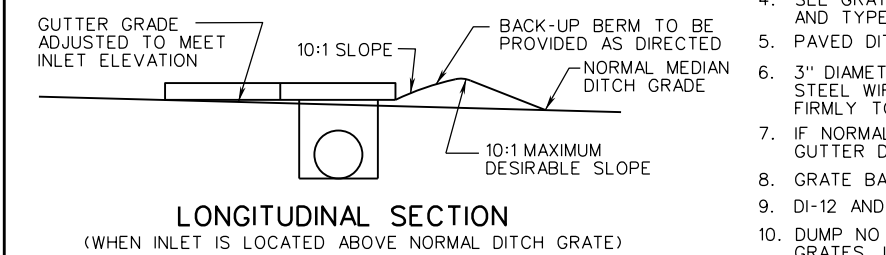
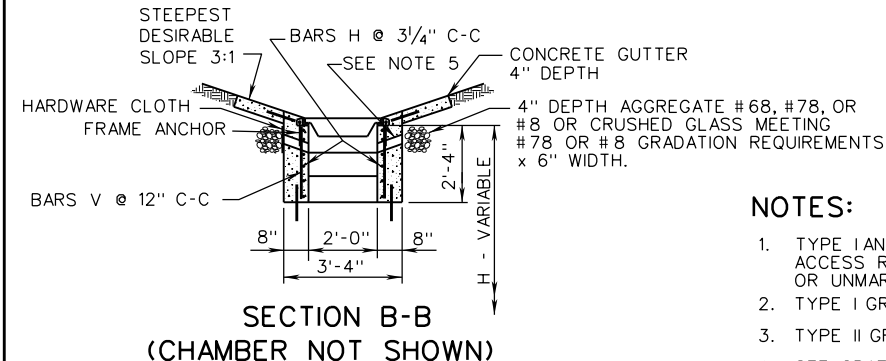
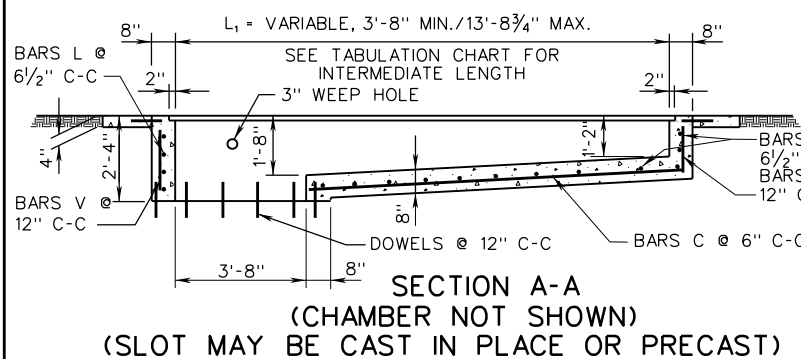
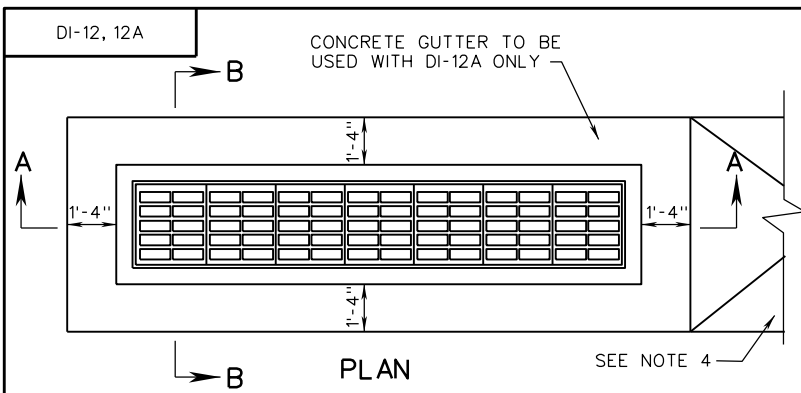

NOTE: SEE GRATE DIMENSION TABLE FOR GRATE TYPE I & II DIMENSIONS

GRATE TYPE	GRATE DIMENSIONS			
	OPENING WIDTH (1)	BAR THICKNESS (2)	END SECTION WIDTH (3)	GRATE THICKNESS (4)
TYPE I	3/4"	1 3/8"	2 1/8"	3 3/4"
TYPE II	1 1/2"	1 3/8"	2 3/16"	3 3/4"

NOTES:

1. TYPE I AND TYPE II GRATES SHALL NOT BE LOCATED WITHIN THE LIMITS OF ANY PEDESTRIAN ACCESS ROUTE, SUCH AS A SIDEWALK, SHARED USE PATH, OR PEDESTRIAN CROSSING (MARKED OR UNMARKED).
2. TYPE I GRATE: LIMITED ACCESS AND RURAL UNLIMITED ACCESS
3. TYPE II GRATE: URBAN AREAS
4. SEE GRATE DIMENSION TABLE FOR SIZE AND NUMBER OF GRATE OPENINGS REQUIRED FOR TYPE I AND TYPE II GRATE.
5. PAVED DITCHES ARE TO BE TRANSITIONED TO MEET INLET GUTTER AS SHOWN IN STANDARD PG-2A.
6. 3" DIAMETER WEEP HOLE WITH 12" X 12" PLASTIC HARDWARE CLOTH 1/4" MESH OR GALVANIZED STEEL WIRE, MINIMUM WIRE DIAMETER 0.03", NUMBER 4 MESH HARDWARE CLOTH ANCHORED FIRMLY TO OUTSIDE OF STRUCTURE.
7. IF NORMAL DITCH GRADE IS TOO FLAT TO ALLOW FOR ADJUSTED GRADE TO INLET, A SPECIAL GUTTER DETAIL WILL BE REQUIRED ON PLANS.
8. GRATE BARS TO BE PARALLEL TO DITCH FLOW.
9. DI-12 AND DI-12A ARE NOT TO BE UTILIZED IN LOCATIONS NORMALLY SUBJECT TO TRAFFIC.
10. DUMP NO WASTE DRAINS TO WATERWAYS LETTERING IS REQUIRED ON ALL DI-12 GRATES. LOCATION OF LETTERING MAY VARY BY MANUFACTURER.

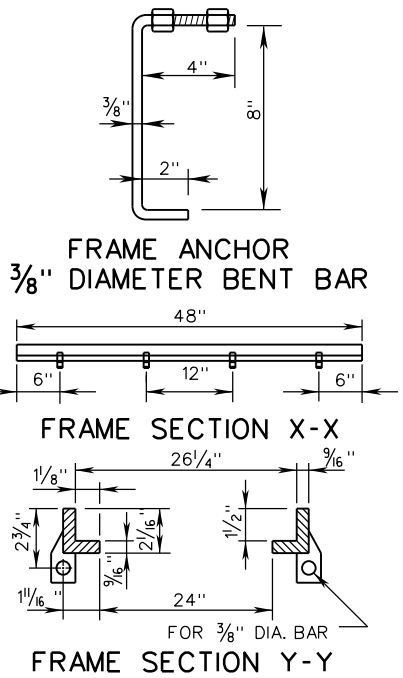

TABULATION CHARTS

APPROXIMATE QUANTITIES (SEE NOTE 2)						
CAST IN PLACE CHAMBER						
PIPE SIZES	MINIMUM DEPTH H (SEE NOTE 3)	REINFORCING STEEL LBS.	CONCRETE CU. YDS.	CHAMBER DIMENSIONS		CONCRETE CHAMBER INCREMENTS PER FOOT (SEE NOTE 1)
				W _C	L _C	CU. YDS.
12" TO 24"	4'-2"	20.5	1.20	2'-6"	3'-8"	.37
27" TO 36"	5'-6 1/4 "	30.33	2.14	3'-8"	3'-8"	.43
42" TO 54"	6'-10 1/2 "	129.80	4.39	5'-5"	5'-5"	.53
60" TO 72"	8'-6"	277.32	7.65	7'-2"	7'-2"	.69

NOTES

1. FOR EACH ADDITIONAL FOOT IN DEPTH THE INCREMENT SHOWN MUST BE MULTIPLIED BY THE ADDITIONAL DEPTH IN FEET AND ADDED TO THE CONCRETE TOTAL.
2. APPROXIMATE QUANTITIES ARE SHOWN FOR BIDDING PURPOSES ONLY: ITEMS ARE NOT TO BE BID SEPARATELY. TO OBTAIN THE TOTAL APPROXIMATE CONCRETE QUANTITIES FOR EACH INLET, THE CHAMBER, SLOT AND GUTTER (GUTTER TO BE USED WITH DI-12A ONLY) QUANTITIES MUST BE ADDED TOGETHER.
3. MINIMUM DEPTHS SHOWN ARE FOR THE SMALLEST PIPE SIZE IN EACH SERIES. MINIMUM DEPTH H = PIPE DIAMETER + PIPE WALL THICKNESS + 3'.
4. FOR APPROXIMATE QUANTITIES FOR DI-12A ADD 0.36 CU. YDS. OF CLASS A3 CONCRETE TO DI-12 QUANTITIES FOR CONCRETE GUTTER. QUANTITY SHOWN IS FOR A MINIMUM SLOT LENGTH OF 3'-8". FOR OTHER CONCRETE LENGTHS SEE CONCRETE GUTTER INCREMENTS IN THIS TABLE.
5. DI-12A CONCRETE GUTTER INCREMENT: ADD 0.07 CU. YDS. CLASS A3 CONCRETE FOR EACH ADDITIONAL FOOT OF SLOT LENGTH GREATER THAN MINIMUM 3'-8".
6. DOWELS ARE TO BE PROVIDED FOR THE JOINT BETWEEN THE CONCRETE GUTTER AND SLOT. THE COST OF DOWELS ARE TO BE INCLUDED IN THE CUBIC YARD COST FOR CONCRETE.
7. SLOT MAY BE PRECAST OR CAST IN PLACE.
8. L = LENGTH ROUNDED FOR PLAN USE.

APPROXIMATE QUANTITIES						
BRICK AND BLOCK CHAMBER						
PIPE SIZES	CHAMBER DIMENSIONS "D"	REINFORCING STEEL LBS.	CONCRETE CU. YDS.	BRICK		BLOCK
				MIN. DEPTH H	NO.	NO.
12" TO 24"	4'-0"	102.68	1.25	4'-2"	688	42
27" TO 36"	4'-0"	102.68	1.25	5'-6 1/4"	911	55
42" TO 54"	5'-6"	200.81	2.01	7'-10 1/2"	1300	111
60" TO 72"	8'-0"	404.74	3.65	9'-6"	1568	190

BRICK CHAMBER INCREMENTS PER FT.

X DIM.	DEPTH	4' DIAMETER APPROX. NO. BRICKS/FT.	5'-6" DIAMETER APPROX. NO. BRICKS/FT.	8'-0" DIAMETER APPROX. NO. BRICKS/FT.
8"	0' - 10'	165	227	330
12"	10' - 16'	250	341	495
16"	16' - 25'	330	454	660

BLOCK CHAMBER INCREMENTS PER FT.

Y DIM.	DEPTH	4' DIAMETER APPROX. NO. BRICKS/FT.	5'-6" DIAMETER APPROX. NO. BRICKS/FT.	8'-0" DIAMETER APPROX. NO. BRICKS/FT.
5"	0' - 12'	10	14	20
10"	12' - 25'	20	28	40

APPROXIMATE QUANTITIES - DI - 12 ONLY

(SEE NOTE 4)

SLOT 4' TO 14'

(SEE NOTE 8)

L (SEE NOTE 8)	L ₁	CONCRETE CU. YDS.	REINFORCING STEEL LBS.	GRATES NO.
4	3'-8"	0.81	81.27	2
6	5'-8 3/4"	1.10	122.81	3
8	7'-8"	1.30	161.90	4
10	9'-8 3/4"	1.61	203.37	5
12	11'-8"	1.91	242.45	6
14	13'-8 3/4"	2.22	283.93	7

SPECIFICATION REFERENCE

233
302

MULTIGRATE DROP INLET

FOR PIPE SIZES 12" TO 72"

VIRGINIA DEPARTMENT OF TRANSPORTATION



ROAD AND BRIDGE STANDARDS

REVISION DATE

SHEET 3 OF 3

104.32

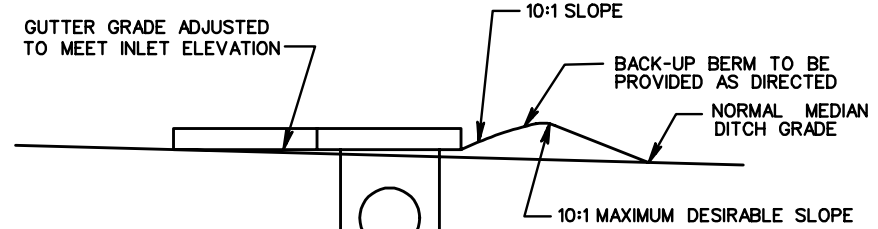
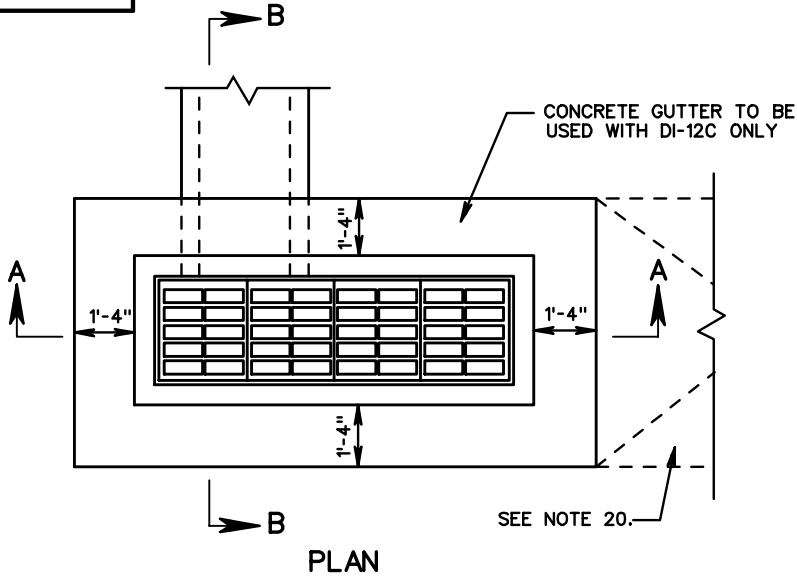

LONGITUDINAL SECTION
(WHEN INLET IS LOCATED ABOVE NORMAL DITCH GRADE)
SEE NOTE 16.

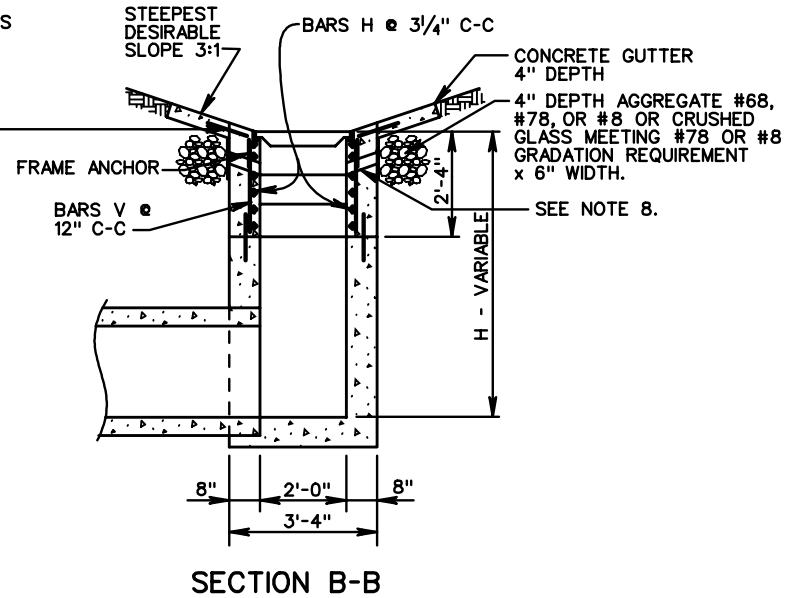
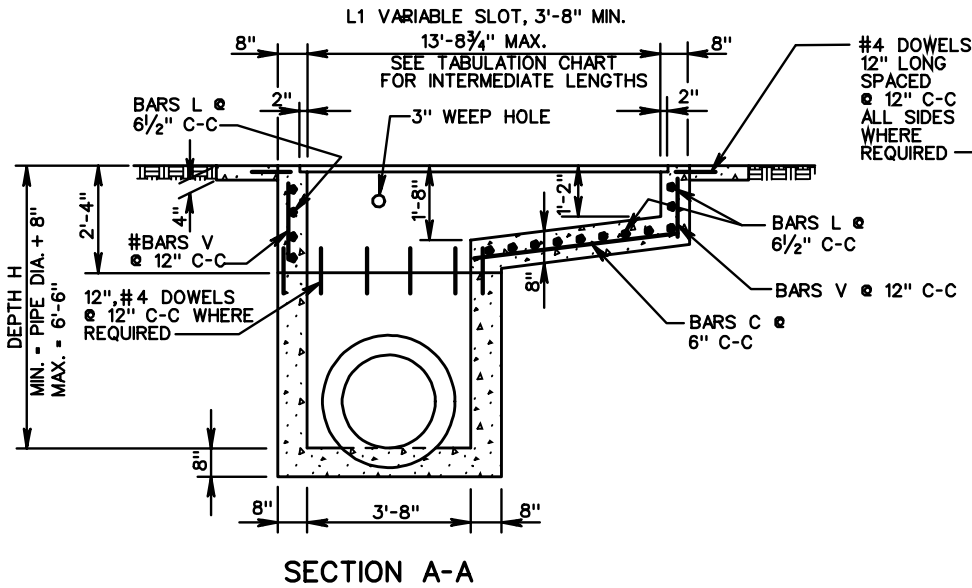

ROAD AND BRIDGE STANDARDS

MULTIGRATE DROP INLET
FOR PIPE SIZES 12" TO 36"
VIRGINIA DEPARTMENT OF TRANSPORTATION

SPECIFICATION REFERENCE

SHEET 1 OF 2

REVISION DATE

241
503

104.33

NOTES

- DEPTH OF INLET (H) TO BE SHOWN ON PLANS. FOR DEPTH GREATER THAN 6'-6", USE ST'D. DI-12, DI-12A.
- LENGTH OF SLOT (L) WILL IN EVERY CASE, BE SHOWN ON PLANS.
- ALL REINFORCING BARS TO BE #4
- DI-12C CONCRETE GUTTER INCREMENT: ADD 0.07 CU. YDS CLASS A3 CONCRETE FOR EACH ADDITIONAL FOOT OF SLOT LENGTH GREATER THAN MINIMUM 3'-8".
- GRATE BARS TO BE INSTALLED SO THEY WILL BE ALIGNED PARALLEL TO THE DITCH FLOW.
- IF NORMAL DITCH GRADE IS TOO FLAT TO ALLOW FOR ADJUSTED GRADE TO INLET A SPECIAL GUTTER DETAIL WILL BE REQUIRED ON PLANS.
- DI-12B-----NO GUTTER
DI-12C-----PERIPHERAL GUTTER
- PAVED DITCHES ARE TO BE TRANSITIONED TO MEET INLET GUTTER AS SHOWN IN STANDARD PG-2A.
- QUANTITIES SHOWN ARE FOR INLETS WITHOUT PIPES. PIPE DISPLACEMENTS MUST BE DEDUCTED TO OBTAIN TRUE QUANTITIES.
- PAVED TRANSITION WHERE REQUIRED ON PLANS. TRANSITION IS TO BE SHAPED TO CONFORM TO ROUNDED CONCRETE GUTTER OF DI-12C.
- TYPE I GRATE: LIMITED ACCESS AND RURAL UNLIMITED ACCESS
- TYPE II GRATE: URBAN AREAS
- L = LENGTH ROUNDED FOR PLAN USE.
- DI-12C: FOR APPROX. QUANTITIES FOR DI-12C, ADD 0.36 CU. YDS. OF CLASS A3 CONCRETE TO DI-12B QUANTITIES FOR CONCRETE GUTTER. QUANTITY SHOWN IS FOR A MINIMUM SLOT LENGTH OF 3'-8". FOR OTHER LENGTHS SEE CONCRETE GUTTER INCREMENT BELOW.
- DI-12B AND DI-12C ARE NOT TO BE UTILIZED IN LOCATIONS NORMALLY SUBJECT TO TRAFFIC.
- DUMP NO WASTE DRAINS TO WATERWAYS LETTERING IS REQUIRED ON ALL DI-12 GRATES. LOCATION OF LETTERING MAY VARY BY MANUFACTURER.
- TYPE I AND TYPE II GRATES SHALL NOT BE LOCATED WITHIN THE LIMITS OF ANY PEDESTRIAN ACCESS ROUTE, SUCH AS A SIDEWALK, SHARED USE PATH, OR PEDESTRIAN CROSSING (MARKED OR UNMARKED).

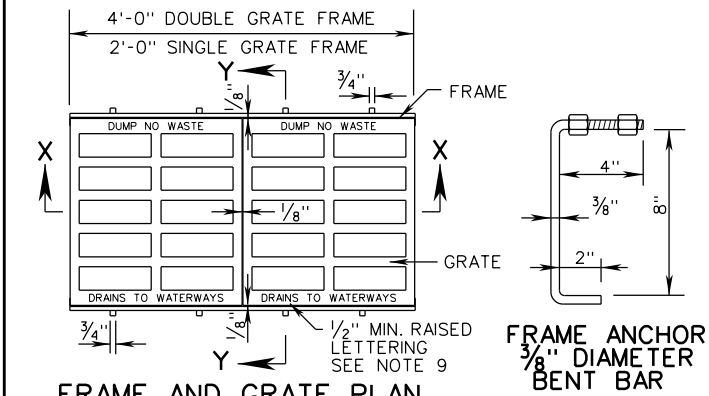

FRAME AND GRATE PLAN

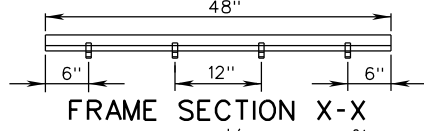

FRAME SECTION X-X

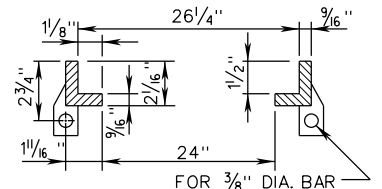

FRAME SECTION Y-Y

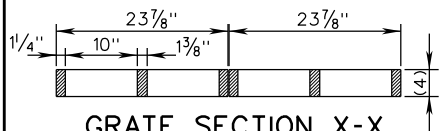

GRATE SECTION X-X

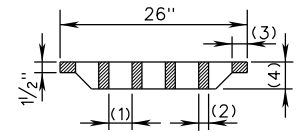

GRATE SECTION Y-Y

NOTE: SEE GRATE DIMENSION TABLE FOR GRATE TYPE I & II DIMENSIONS

GRATE DIMENSIONS				
GRATE TYPE	OPENING WIDTH (1)	BAR THICKNESS (2)	END SECTION WIDTH (3)	GRATE THICKNESS (4)
TYPE I	3 1/4"	1 3/8"	2 1/8"	3 3/4"
	5 OPENINGS	4 BARS		
TYPE II	1 1/2"	1 3/8"	2 3/8"	3 3/4"
	8 OPENINGS	7 BARS		

TABULATION CHARTS

APPROXIMATE QUANTITIES DI-12B ONLY (SEE NOTES 19 & 24)					
(MINIMUM HEIGHT) SLOT 4' TO 14' (SEE NOTE 23)					
L (SEE NOTE 23)	L1	CONCRETE CU. YDS.	REINFORCING STEEL LBS.	NUMBER GRATES	CONCRETE CHAMBER INCREMENTS PER FOOT CU. YDS.
4	3'-8"	0.99	81.27	2	.35
6	5'-8 3/4"	1.28	122.81	3	
8	7'-8"	1.48	161.90	4	
10	9'-8 3/4"	1.79	203.37	5	
12	11'-8"	2.09	242.45	6	
14	13'-8 3/4"	2.40	283.93	7	

SPECIFICATION REFERENCE
241 503

MULTIGRATE DROP INLET
FOR PIPE SIZES 12" TO 36"
VIRGINIA DEPARTMENT OF TRANSPORTATION

VDOT ROAD AND BRIDGE STANDARDS	
REVISION DATE 08/14	SHEET 2 OF 2 104.34

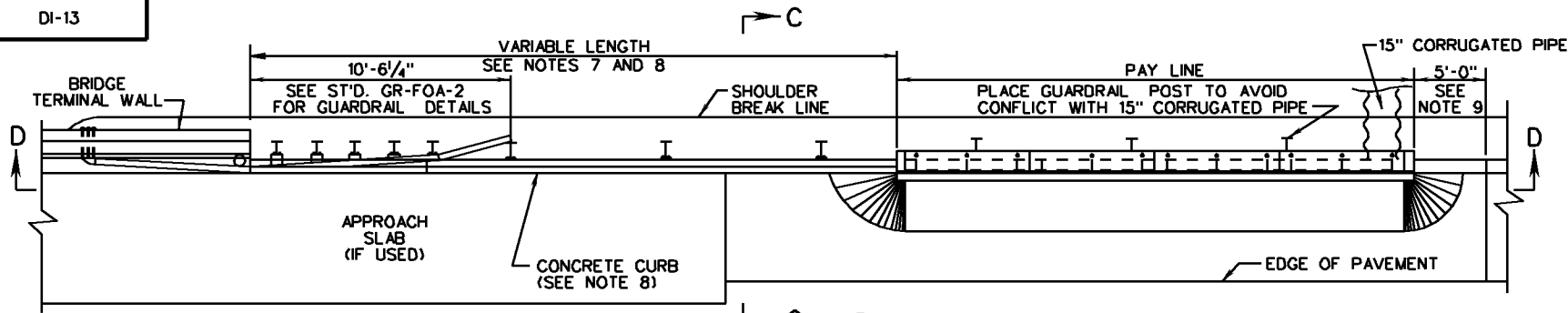

PLAN
(BRIDGE RUN ON & RUN OFF LOCATION)

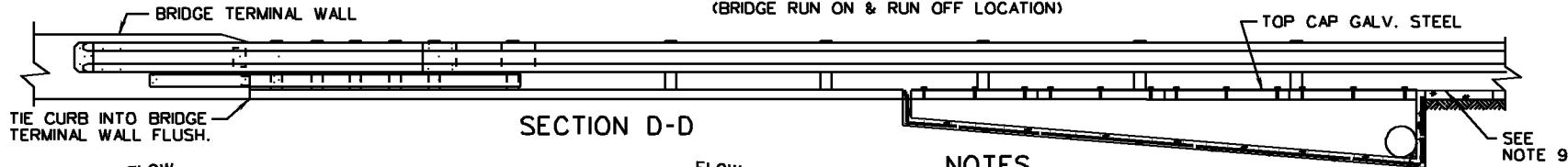

SECTION D-D

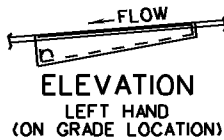

ELEVATION
LEFT HAND
(ON GRADE LOCATION)

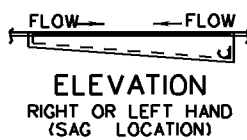

ELEVATION
RIGHT OR LEFT HAND
(SAG LOCATION)

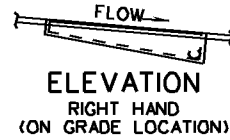

ELEVATION
RIGHT HAND
(ON GRADE LOCATION)

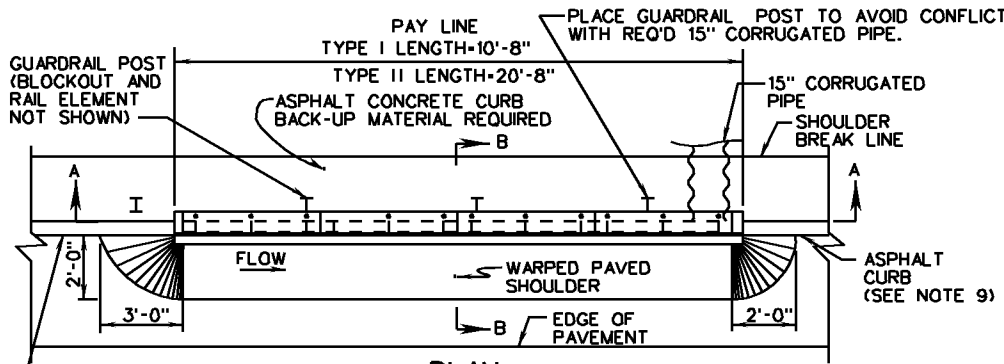

PLAN
(ROADWAY LOCATION)

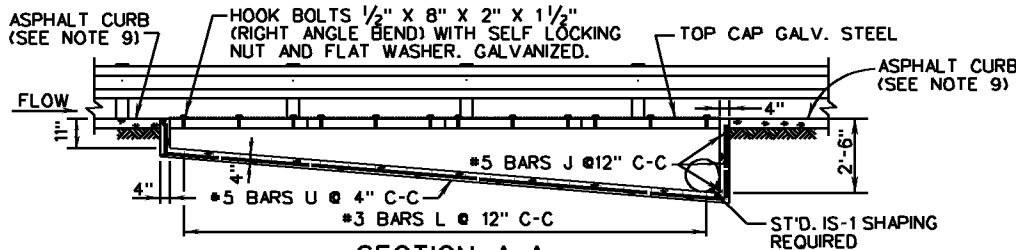

SECTION A-A

NOTES

1. THIS UNIT MAY BE PRECAST OR CAST IN PLACE. CAST IN PLACE CONCRETE IS TO BE CLASS A3 (3000 PSI). PRECAST CONCRETE IS TO BE 4000 PSI.
2. ALL REINFORCING STEEL IS TO BE GRADE 60.
3. PIPES ARE TO BE PLACED ON THE DOWN GRADE OR LOWER END OF INLET.
4. PRECAST UNITS MUST BE FURNISHED WITH PIPES PLACED TO THE RIGHT OR LEFT ACCORDING TO THE FLOW DOWN GRADE, WHEN FACING THE INLET FROM THE CENTER OF THE ROAD.
5. WHEN THIS INLET IS USED IN A SAG LOCATION EITHER A RIGHT HAND OR A LEFT HAND UNIT MAY BE USED.
6. BACKFILL TO BE PLACED AND COMPACTED IN ACCORDANCE WITH SECTION 303.09 OF THE ROAD AND BRIDGE SPECIFICATIONS.
7. DI-13 STRUCTURE SHALL BE LOCATED A MINIMUM OF 11 FEET FROM THE END OF THE BRIDGE TERMINAL WALL. IN LOCATIONS THAT INCLUDE AN APPROACH SLAB EXTENDING BEYOND THE END OF THE BRIDGE TERMINAL WALL, THE DI13 STRUCTURE SHALL BE PLACED A MINIMUM OF 5 FEET BEYOND THE END OF THE APPROACH SLAB.
8. STANDARD CG-3 CONCRETE CURB SHALL BE PLACED FROM THE END OF THE INLET TO THE BEGINNING OF THE BRIDGE TERMINAL WALL. ASPHALT CONCRETE CURB BACK UP MATERIAL SHALL BE PLACED BEHIND CG-3 AS SHOWN IN SECTION C-C. THE COST OF CG-3 CURB AND ASPHALT CONCRETE CURB BACK UP MATERIAL SHALL BE PAID FOR SEPERATELY FROM THE DI-13 STRUCTURE.
9. STANDARD MC-3B ASPHALT CURB SHALL BE EXTENDED 5 FEET PAST THE END OF THE INLET AND TRANSITION DOWN TO GRADE LEVEL. LONGER LENGTHS OF CURB MAY BE NEEDED BEYOND THIS LIMIT AND THEN TRANSITIONED DOWN IN 5 FEET. SEE THE ROADWAY PLANS FOR THE REQUIRED LENGTH OF CURB. THE COST OF MC-3B CURB AND ASPHALT CONCRETE CURB BACKUP MATERIAL SHALL BE PAID FOR SEPERATELY FROM THE DI-13 STRUCTURE.
10. FOR DETAILS OF SLOT INLET AND PIPE INSTALLATION, SEE SECTION B-B ON SHEET 2 OF 2.



ROAD AND BRIDGE STANDARDS

SHEET 1 OF 2

REVISION DATE

104.35

10/09

SHOULDER SLOT INLET

VIRGINIA DEPARTMENT OF TRANSPORTATION

SPECIFICATION
REFERENCE

233
302

NOTES

1. SEE SHEET 1 OF 2 (104.35) OF ROAD AND BRIDGE STANDARDS FOR ADDITIONAL DESIGN AND PLACING INFORMATION.
2. TOP CAP IS TO BE FABRICATED FROM A-36 STEEL PLATE 1/4" THICK. ALL JOINTS ARE TO BE WELDED USING 1/4" FILLET WELDS AND THE COMPLETE UNIT IS TO BE GALVANIZED.
3. GUARDRAIL MUST BE FLUSH WITH THE FACE OF CURB.

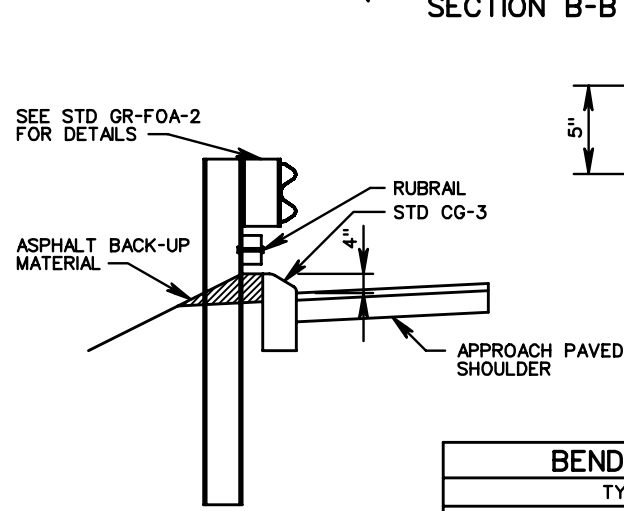
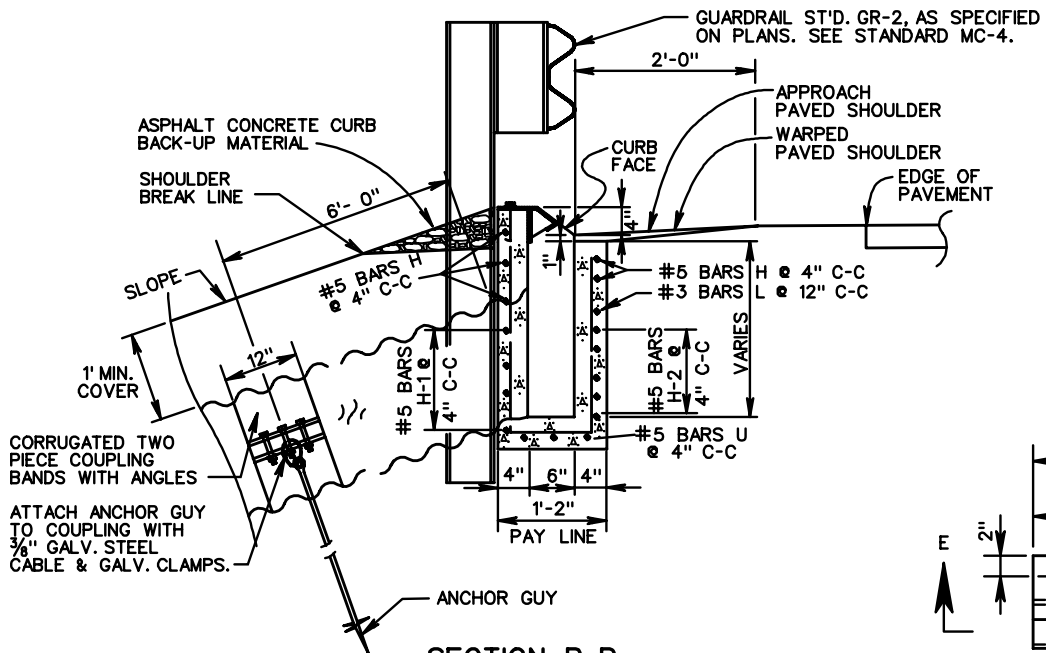

TYPE I		TYPE II	
MARK	X	MARK	X
U	10'-5 1/2"	U	20'-4 3/4"

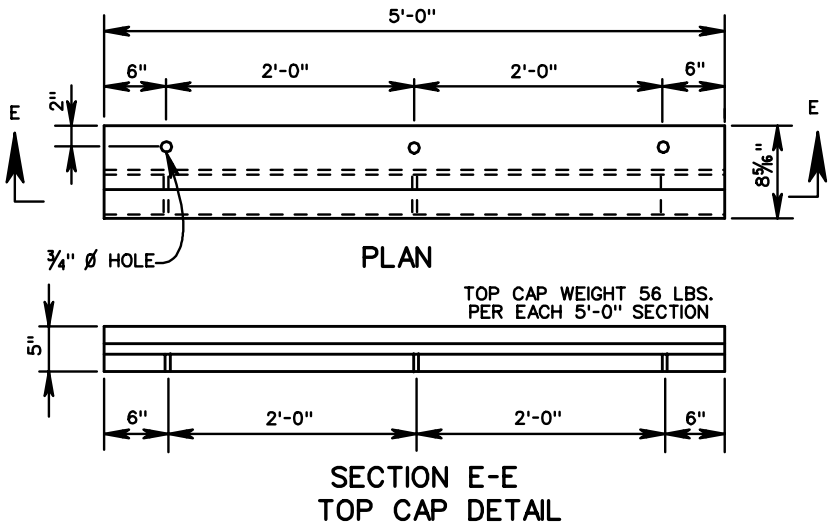
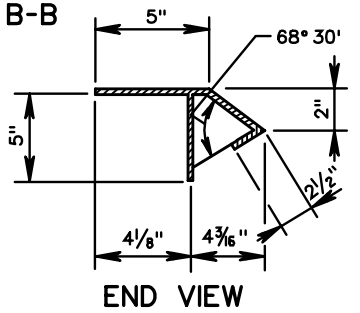

TYPICAL METHOD OF INSTALLATION FOR PIPE ON FILL SLOPE

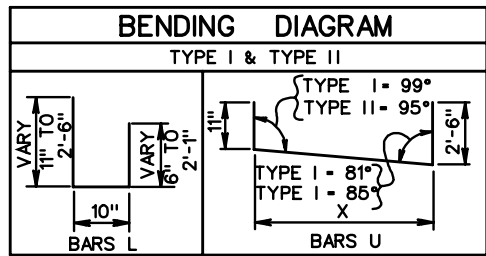

REINFORCING STEEL SCHEDULE									
TYPE I					TYPE II				
MARK	SIZE	NO.	SPA.	LENGTH	MARK	SIZE	NO.	SPA.	LENGTH
H	#5	6	4"	10'-4"	H	#5	6	4"	20'-4"
H-1	#5	4	4"	8'-11" TO 2'-8"	H-1	#5	4	4"	12'-8" TO 2'-8"
H-2	#5	4	4"	8'-11" TO 2'-8"	H-2	#5	4	4"	12'-8" TO 2'-8"
J	#5	5	12"	0'-10"	J	#5	5	12"	0'-10"
L	#5	11	12"	5'-5" TO 2'-3"	L	#5	21	12"	5'-5" TO 2'-3"
U	#5	3	4"	13'-10"	U	#5	3	4"	23'-10"

SPECIFICATION REFERENCE
233
302

SHOULDER SLOT INLET

VIRGINIA DEPARTMENT OF TRANSPORTATION

VDOT	
ROAD AND BRIDGE STANDARDS	
REVISION DATE	SHEET 2 OF 2
104.36	

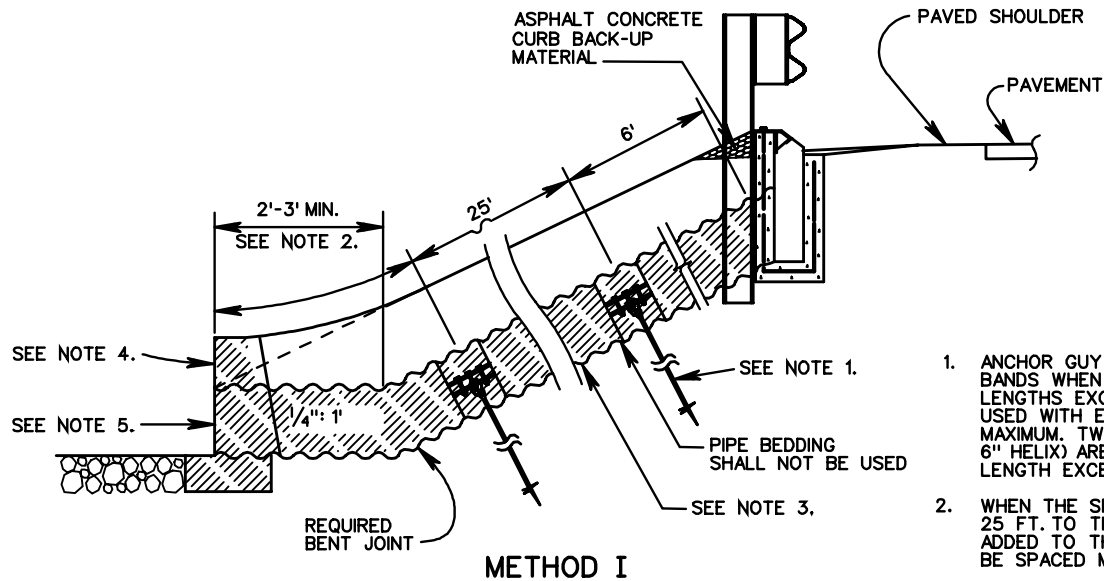

METHOD I

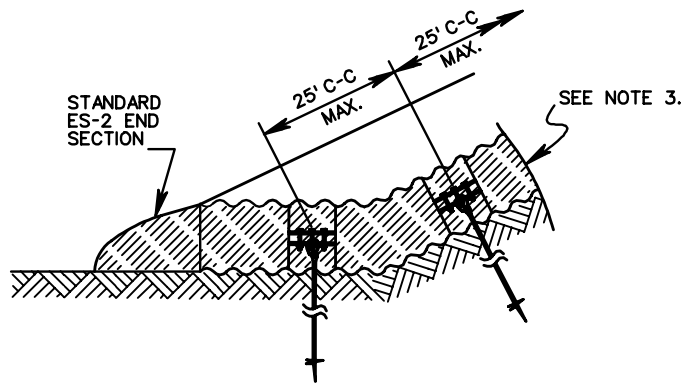

METHOD II

NOTES

1. ANCHOR GUY SCREWS ARE NOT TO BE USED WITH THE COUPLING BANDS WHEN THE PIPE LENGTHS ARE LESS THAN 50 FT. WHEN PIPE LENGTHS EXCEED 50 FT. TWO (2) ANCHOR GUY SCREWS ARE TO BE USED WITH EACH COUPLING BAND SPACED AT 25 FT. C-C MAXIMUM. TWO (2) ANCHOR GUY SCREWS, (1/2" DIAMETER X 5'-6", 6" HELIX) ARE TO BE USED WITH EACH COUPLING BAND, WHEN PIPE LENGTH EXCEEDS 50 FT.
2. WHEN THE SPACING OF THE LOWER COUPLING FALLS CLOSER THAN 25 FT. TO THE STORM SYSTEM STRUCTURE THE DISTANCE IS TO BE ADDED TO THE LAST FULL 12'-6" SPACE AND THE COUPLING IS TO BE SPACED MID-WAY OF THE TOTAL DISTANCE.
3. REQUIRED 15" CORRUGATED PIPE. SEE PLAN FOR LIN. FT. QUANTITIES. THE LIN. FT. COST FOR THE PIPE IS TO INCLUDE FURNISHING AND PLACING COUPLINGS AND ANCHOR GUYS. CORRUGATED POLY-ETHYLENE PIPE LENGTHS GREATER THAN 50 FT. MAY BE USED AS AN ALTERNATE PROVIDED THE COUPLING BAND ANCHORAGE DESIGN IS SUBMITTED BY THE MANUFACTURER FOR THE ENGINEER'S REVIEW AND APPROVAL.
4. REQUIRED 15" CORRUGATED PIPE MUST BE TERMINATED AT THE TOE OF FILL SLOPE WITH AN APPROPRIATE END TREATMENT. FOR 3:1 SLOPES AND FLATTER THE PIPE MAY BE TERMINATED WITH A STANDARD ES-2 END SECTION OR TIED INTO ANOTHER DRAINAGE STRUCTURE. FOR SLOPES 3:1 AND STEEPER (MAX. 1/2:1) THE 15" PIPE MUST HAVE ONE OF THE FOLLOWING END TREATMENTS (SEE PLANS FOR REQUIRED TYPE OF STRUCTURE):
 - METHOD I: TERMINATE PIPE WITH A STANDARD END WALL OR OTHER DRAINAGE STRUCTURE, TO BE APPROVED BY THE ENGINEER. FOR PIPE LENGTHS LONGER THAN 50 FT., COUPLING BANDS WITH ANCHOR GUYS ARE TO BE USED AT 12'-6" C-C MAXIMUM SPACING.
 - METHOD II: TERMINATE PIPE WITH A STANDARD ES-2 END SECTION ANCHORED WITH COUPLING BAND AND ANCHOR GUYS. ADDITIONAL COUPLING BANDS AND ANCHOR GUYS ARE TO BE PLACED AT 12'-6" C-C MAXIMUM FOR THE REMAINING LENGTH OF PIPE.
5. MORTAR REQUIRED CORRUGATED PIPE INTO THE WALL IF PRECAST STRUCTURE IS USED.



ROAD AND BRIDGE STANDARDS

METHOD OF OUTLET PIPE INSTALLATION FOR DI-13

SPECIFICATION REFERENCE

SHEET 1 OF 1

REVISION DATE

VIRGINIA DEPARTMENT OF TRANSPORTATION

104.37

232
302

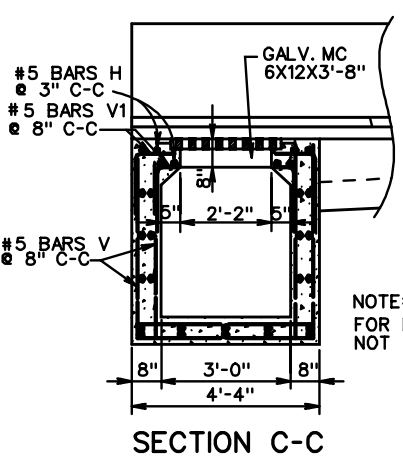
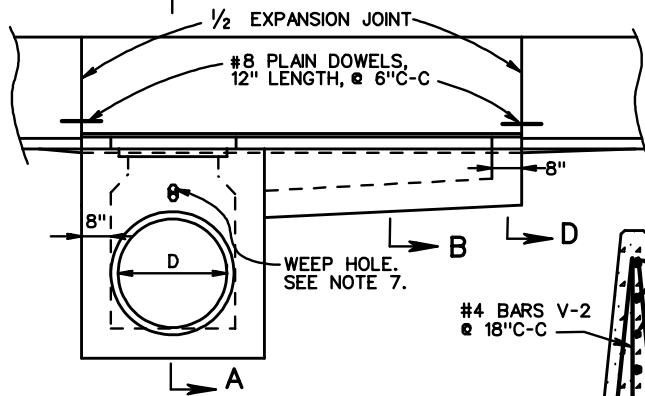
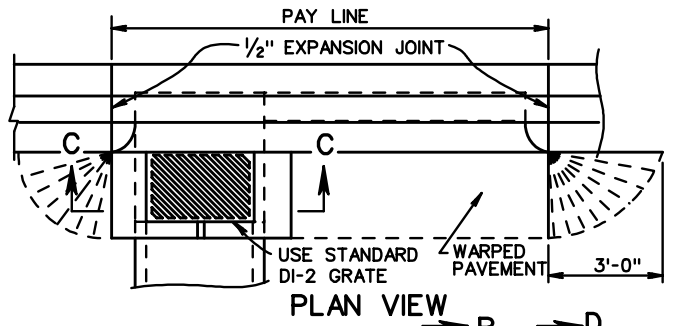

NOTE:
FOR DIMENSIONS, QUANTITIES AND NOTES
NOT SHOWN SEE SHEET 2 OF 2.

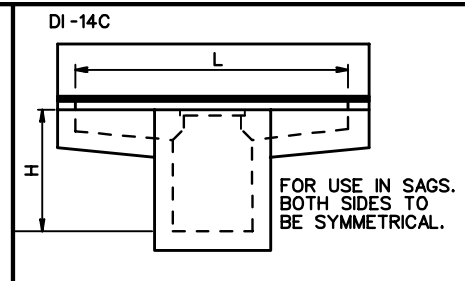
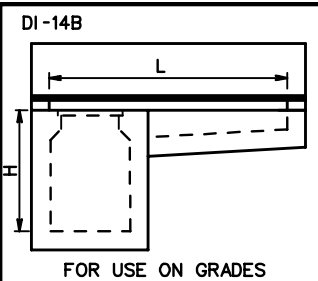
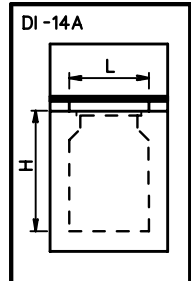
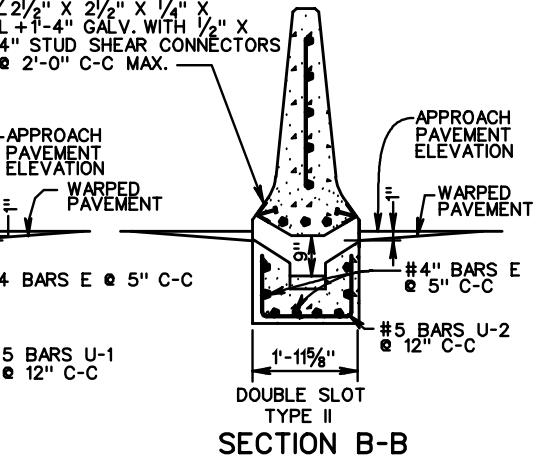
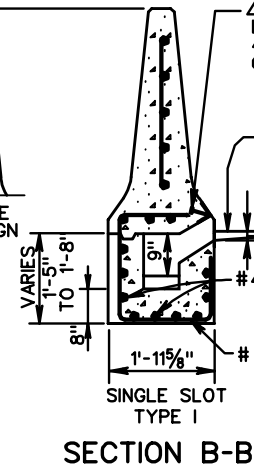
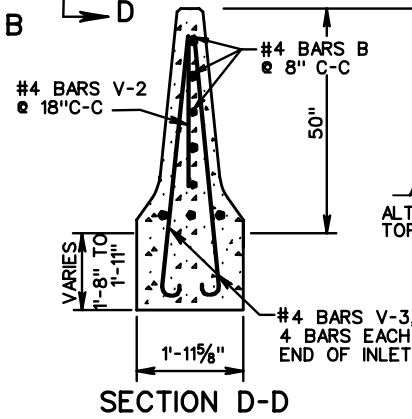
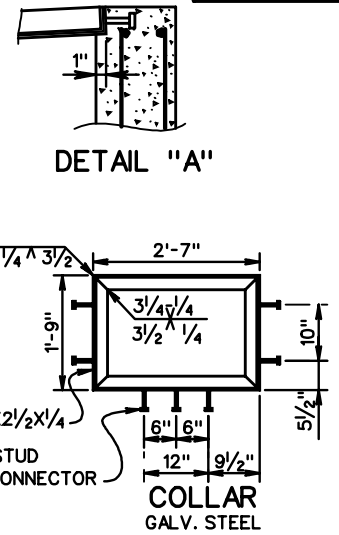
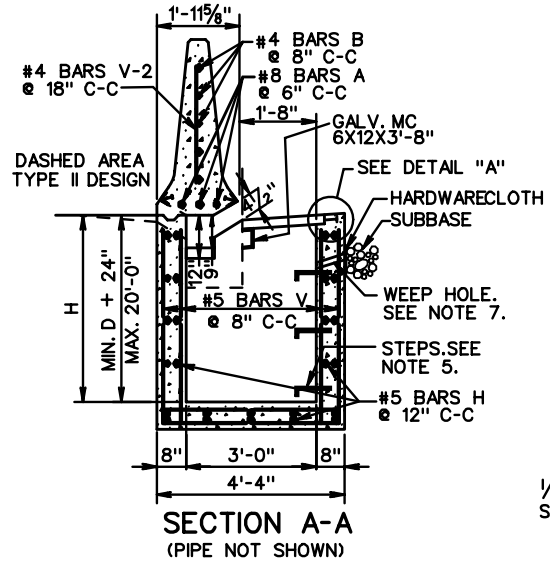

FOR USE ON GRADES

FOR USE IN SAGS.
BOTH SIDES TO
BE SYMMETRICAL.

SPECIFICATION REFERENCE
233
302

CONCRETE MEDIAN BARRIER DROP INLET
12"-36" PIPE: DEPTH (H)-20'-0" MAX.
VIRGINIA DEPARTMENT OF TRANSPORTATION

VDOT	
ROAD AND BRIDGE STANDARDS	
REVISION DATE	SHEET 1 OF 2
104.38	

TABLE OF QUANTITIES

TYPE	L	CONCRETE				REINFORCING STEEL																					
		TYPE I		TYPE II		BARS A		BARS B		BARS E		BARS H		BARS U-1		BARS U-2		BARS V		BARS V-1		BARS V-2		BARS V-3		TYPE I	TYPE II
		FT.	CU. YD.	CU. YD.	NO.	LN.*FT.	NO.	LN.*FT.	NO.	LN.*FT.	NO.	LN.*FT.	NO.	LN.*FT.	NO.	LN.*FT.	NO.	LN.*FT.	NO.	LN.*FT.	NO.	LN.*FT.	NO.	LN.*FT.	NO.	LN.*FT.	Lbs.
DI-14A	3'	2.23	2.20	3	4'-0"	5	4'-0"	-	-	38	4'-0"	-	-	-	-	48	3'-4"	12	2'-6"	3	3'-8"	8	5'-9"	455	455		
DI-14B	4'	2.45	2.44	3	5'-0"	5	5'-0"	8	1'-4"	38	4'-0"	2	5'-2" TO 5'-8"	2	3'-1" TO 3'-7"	48	3'-4"	12	2'-6"	4	3'-8"	8	5'-9"	485	480		
	6'	2.91	2.89	3	7'-0"	5	7'-0"	8	3'-4"	38	4'-0"	4	5'-2" TO 5'-8"	4	3'-1" TO 3'-7"	48	3'-4"	12	2'-6"	5	3'-8"	8	5'-9"	528	519		
	8'	3.36	3.34	3	9'-0"	5	9'-0"	8	5'-4"	38	4'-0"	6	5'-2" TO 5'-8"	6	3'-1" TO 3'-7"	48	3'-4"	12	2'-6"	7	3'-8"	8	5'-9"	573	560		
	10'	3.82	3.78	3	11'-0"	5	11'-0"	8	7'-4"	38	4'-0"	8	5'-2" TO 5'-8"	8	3'-1" TO 3'-7"	48	3'-4"	12	2'-6"	8	3'-8"	8	5'-9"	617	600		
	12'	4.28	4.24	3	13'-0"	5	13'-0"	8	9'-4"	38	4'-0"	10	5'-2" TO 5'-8"	10	3'-1" TO 3'-7"	48	3'-4"	12	2'-6"	9	3'-8"	8	5'-9"	660	639		
	14'	4.74	4.69	3	15'-0"	5	15'-0"	8	11'-4"	38	4'-0"	12	5'-2" TO 5'-8"	12	3'-1" TO 3'-7"	48	3'-4"	12	2'-6"	11	3'-8"	8	5'-9"	706	679		
	16'	5.20	5.14	3	17'-0"	5	17'-0"	8	13'-4"	38	4'-0"	14	5'-2" TO 5'-8"	14	3'-1" TO 3'-7"	48	3'-4"	12	2'-6"	12	3'-8"	8	5'-9"	749	719		
	18'	5.67	5.61	3	19'-0"	5	19'-0"	8	15'-4"	38	4'-0"	16	5'-2" TO 5'-8"	16	3'-1" TO 3'-7"	48	3'-4"	12	2'-6"	13	3'-8"	8	5'-9"	793	758		
	20'	6.13	6.06	3	21'-0"	5	21'-0"	8	17'-4"	38	4'-0"	18	5'-2" TO 5'-8"	18	3'-1" TO 3'-7"	48	3'-4"	12	2'-6"	15	3'-8"	8	5'-9"	838	799		
DI-14C	6'	2.91	2.89	3	7'-0"	5	7'-0"	16	2'-0"	38	4'-0"	6	5'-2" TO 5'-8"	6	3'-1" TO 3'-7"	48	3'-4"	12	2'-6"	5	3'-8"	8	5'-9"	543	530		
	8'	3.36	3.34	3	9'-0"	5	9'-0"	16	3'-0"	38	4'-0"	8	5'-2" TO 5'-8"	8	3'-1" TO 3'-7"	48	3'-4"	12	2'-6"	7	3'-8"	8	5'-9"	588	571		
	10'	3.82	3.79	3	11'-0"	5	11'-0"	16	4'-0"	38	4'-0"	10	5'-2" TO 5'-8"	10	3'-1" TO 3'-7"	48	3'-4"	12	2'-6"	8	3'-8"	8	5'-9"	632	610		
	12'	4.28	4.24	3	13'-0"	5	13'-0"	16	5'-0"	38	4'-0"	12	5'-2" TO 5'-8"	12	3'-1" TO 3'-7"	48	3'-4"	12	2'-6"	9	3'-8"	8	5'-9"	675	646		
	14'	4.74	4.69	3	15'-0"	5	15'-0"	16	6'-0"	38	4'-0"	14	5'-2" TO 5'-8"	14	3'-1" TO 3'-7"	48	3'-4"	12	2'-6"	11	3'-8"	8	5'-9"	720	690		
	16'	5.20	5.14	3	17'-0"	5	17'-0"	16	7'-0"	38	4'-0"	16	5'-2" TO 5'-8"	16	3'-1" TO 3'-7"	48	3'-4"	12	2'-6"	12	3'-8"	8	5'-9"	764	729		
	18'	5.67	5.61	3	19'-0"	5	19'-0"	16	8'-0"	38	4'-0"	18	5'-2" TO 5'-8"	18	3'-1" TO 3'-7"	48	3'-4"	12	2'-6"	13	3'-8"	8	5'-9"	807	768		
	20'	6.13	6.06	3	21'-0"	5	21'-0"	16	9'-0"	38	4'-0"	20	5'-2" TO 5'-8"	20	3'-1" TO 3'-7"	48	3'-4"	12	2'-6"	15	3'-8"	8	5'-9"	853	809		

NOTES

- DEPTH OF INLET (H) TO BE SHOWN ON PLANS.
- THE "H" DIMENSION SHOWN ON THE STANDARDS AND SPECIFIED ON THE PLANS WILL BE MEASURED FROM THE INVERT OF THE OUTFALL PIPE TO THE TOP OF THE STRUCTURE. PLAN "H" DIMENSIONS ARE APPROXIMATE ONLY FOR ESTIMATING PURPOSES AND THE ACTUAL DIMENSIONS SHALL BE DETERMINED BY THE CONTRACTOR FROM FIELD CONDITIONS.
- WHEN SPECIFIED ON THE PLANS THE INVERT IS TO BE SHAPED IN ACCORDANCE WITH STANDARD IS-1. THE COST OF FURNISHING AND PLACING ALL MATERIALS INCIDENTAL TO THE SHAPING IS TO BE INCLUDED IN THE BID PRICE FOR THE STRUCTURE.
- IN THE EVENT THE INVERT OF THE OUTFALL PIPE IS HIGHER THAN THE BOTTOM OF THE STRUCTURE, THE INVERT OF THE STRUCTURE SHALL BE SHAPED WITH CEMENT MORTAR TO PREVENT STANDING OR PONDING OF WATER IN THE STRUCTURE. THE COST OF FURNISHING AND PLACING ALL MATERIALS INCIDENTAL TO THE SHAPING IS TO BE INCLUDED IN THE BID PRICE FOR THE STRUCTURE.
- STEPS ARE TO BE PROVIDED WHEN H IS 4'-0" OR GREATER. FOR DETAILS SEE STANDARD ST-1.
- THIS ITEM MAY BE PRECAST OR CAST-IN-PLACE.
- 3" DIAMETER WEEP HOLE TO BE LOCATED TO DRAIN SUBBASE MATERIAL. WEEP HOLE WITH 12"X12" PLASTIC HARDWARE CLOTH 1/4" MESH OR GALVANIZED STEEL WIRE, MINIMUM WIRE DIAMETER 0.03", NUMBER 4 MESH HARDWARE CLOTH ANCHORED FIRMLY TO THE OUTSIDE OF THE STRUCTURE.
- ALL REINFORCING STEEL SHALL HAVE A MIN. COVER OF 2".
- ALL REINFORCING STEEL TO BE CUT CLEAR OF ALL OPENINGS BY 2".
- CAST-IN PLACE CONCRETE IS TO BE CLASS A3 (3000 PSI). PRECAST CONCRETE IS TO BE 4000 PSI.
- LENGTH OF SLOT (L) WILL, IN EVERY CASE, BE SHOWN ON PLANS.
- CONCRETE QUANTITIES SHOWN ARE FOR DEPTH (H) OF 3'-0" WITHOUT PIPES. THE AMOUNT DISPLACED BY PIPES MUST BE DEDUCTED TO OBTAIN TRUE QUANTITIES. FOR INLETS OF DIFFERENT DEPTHS ADD OR SUBTRACT 0.36 CUBIC YARDS OF CONCRETE FOR EACH FOOT OF DEPTH. AND 84 LBS. OF REINFORCING STEEL.
- LENGTH OF ANGLE IRON AS SHOWN ON SHEET 1 OF 2 IS TO BE L + 16" AT 4.10 LBS./FT..
- * DENOTES LENGTH OF ONE (1) BAR.
- GRATE TO BE INSTALLED SO SLOTS WILL DIRECT WATER TOWARD THE INLET THROAT. GRATE MUST BE REVERSIBLE (RIGHT HAND GRATE IS SHOWN).
- PROVIDE SAFETY SLABS WHEN SPECIFIED ON THE PLANS.
- FOR DETAILS AND DIMENSIONS NOT SHOWN FOR MEDIAN BARRIER SEE STANDARD MB-12.
- QUANTITIES INCLUDE MB-12.



ROAD AND BRIDGE STANDARDS

SHEET 2 OF 2

REVISION DATE

104.39

CONCRETE MEDIAN BARRIER DROP INLET

12"-36" PIPE: DEPTH (H) = 20'-0" MAX.

VIRGINIA DEPARTMENT OF TRANSPORTATION

SPECIFICATION
REFERENCE233
302

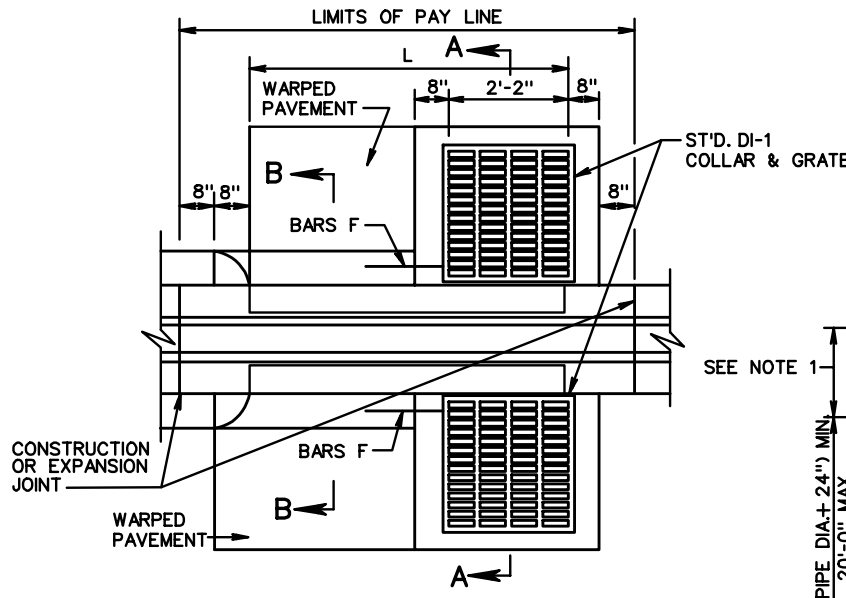

PLAN VIEW

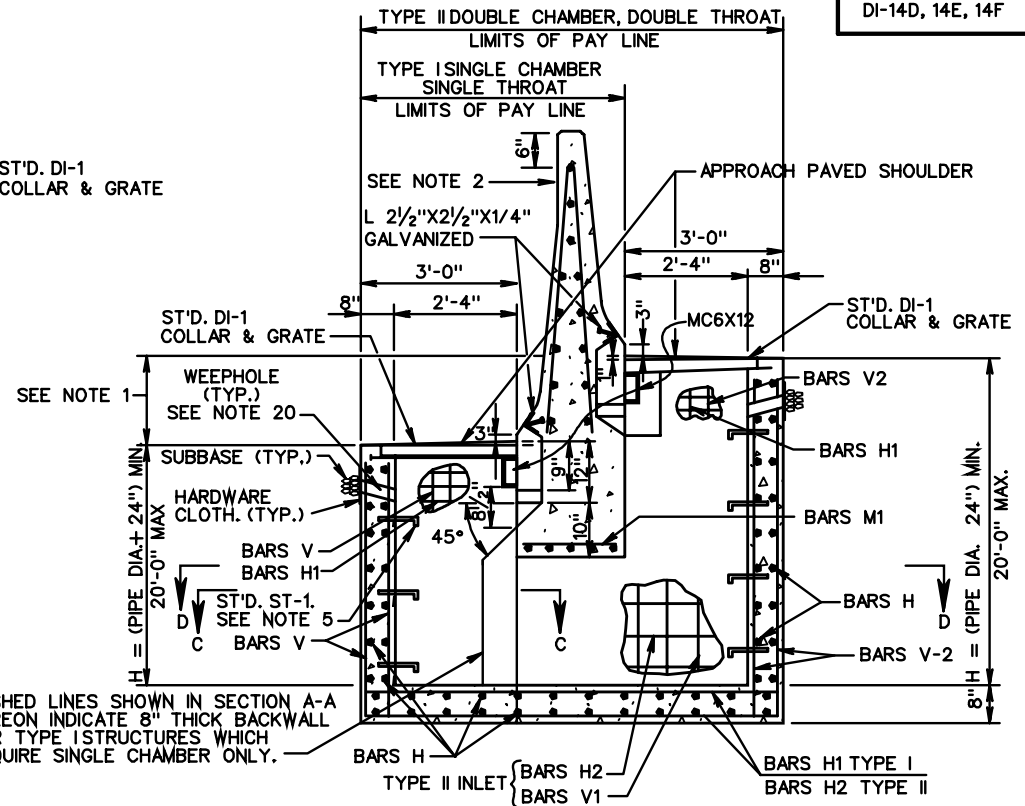

SECTION A-A

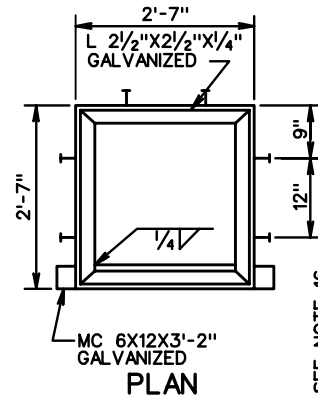

PLAN

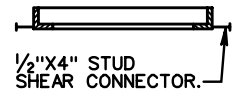

SECTION COLLAR DETAIL

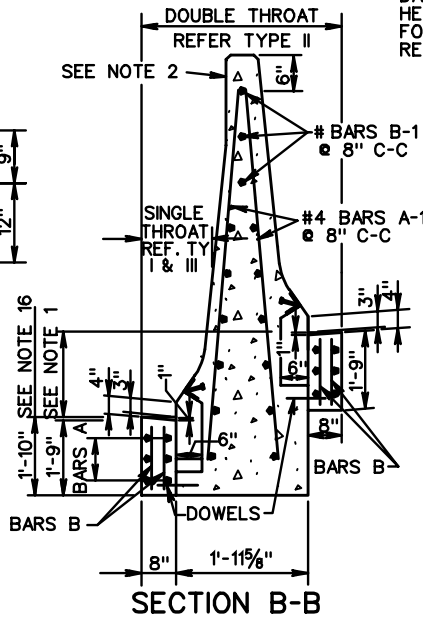

SECTION B-B

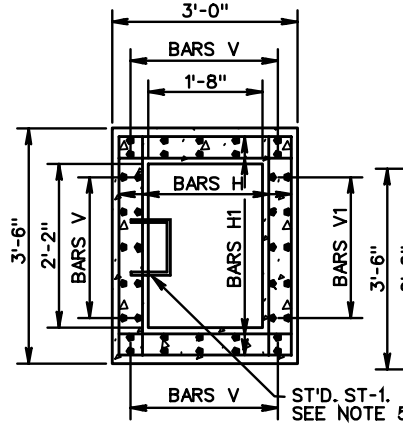

SECTION C-C TYPE I & III

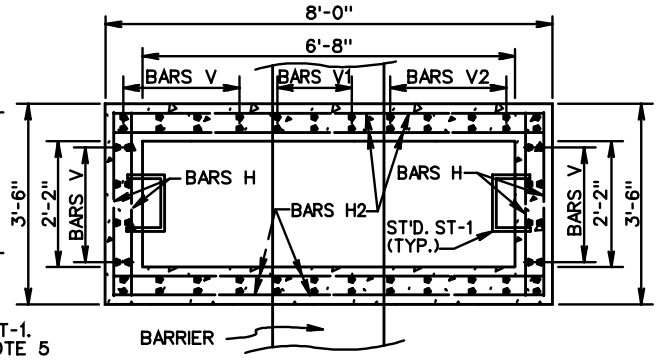

SECTION D-D TYPE II (NOT TO SCALE)

SEE NOTES ON SHEET 2 OF 2.

SPECIFICATION REFERENCE
233 302

CONCRETE MEDIAN BARRIER DROP INLET

12"-24" PIPE: DEPTH (H) - 20' MAX.

VIRGINIA DEPARTMENT OF TRANSPORTATION

VDOT	
ROAD AND BRIDGE STANDARDS	
REVISION DATE	SHEET 1 OF 2
104.40	

NOTES

- VARIES GREATER THAN: 0' TO 18" MAX. TYPE I CHAMBER. 4" TO 3' MAX. TYPE I CHAMBER.
- FOR DETAILS AND DIMENSIONS NOT SHOWN FOR MEDIAN BARRIER, SEE STANDARD MB-13.
- GALVANIZED MC-6 X 12 IS TO BE WELDED UNDER THE COLLAR AND EXTENDED INTO SIDEWALLS TO WITHIN 2" OF OUTSIDE FACE.
- ALL REINFORCING BARS ARE TO BE GRADE 60 STEEL WITH MIN. OF 1/2" CONCRETE COVER. ANY BARS IN CONFLICT WITH PIPE SHELL AND/OR TOP SLAB OPENING ARE TO BE FIELD CUT TO PROVIDE THE REQUIRED COVER.
- DO NOT LOCATE STANDARD ST-1 STEPS ON CHAMBER WALLS THAT HAVE PIPES WHEN POSSIBLE.
- 8 DOWELS REQUIRED FOR DI-14F, MIN. L = 7'-0". ADD 2 DOWELS FOR EACH ADDITIONAL FOOT. 4 DOWELS REQUIRED FOR DI-14E, MIN. L = 4'-0". ADD 2 DOWELS FOR EACH ADDITIONAL FOOT.
- 12 BARS A REQUIRED FOR DI-14F.
- LENGTH OF BARS A, DI-14F = $\frac{L - (2' - 6")}{2}$
- DO NOT USE WITH DI-14D.
- USE 6 BARS F FOR DI-14F TYPE I.
- DO NOT USE WITH TYPE III
- ADD 4 ADDITIONAL BARS FOR EACH EXTRA FOOT OF DEPTH.
- USE 12 BARS F FOR DI-14F TYPE II
- 24 BARS A ARE REQUIRED FOR DI-14F.
- A MINIMUM 22" FOOTING DEPTH IS REQUIRED FOR FORMING THE INLET SLOT. SEE PLANS FOR LENGTH "L".
- REFER TO PLANS FOR STRUCTURE LOCATIONS, DATA AND DIMENSIONS.
- REFER TO PLANS FOR LOCATIONS OF PIPES AND INVERTS.
- FOR TYPE III, COST OF ACCOMMODATION OF INLET THROAT IS TO BE INCLUDED IN COST OF WALL BARRIER.
- FOR TYPE III, SEE WALL PLANS FOR WALL FOOTING DETAILS.
- 3" DIAMETER WEEP HOLE WITH 12"X12" PLASTIC HARDWARE CLOTH, 1/4" MESH OR GALV. STEEL WIRE, MIN. WIRE DIA. 0.03", NO. 4 MESH HARDWARE CLOTH ANCHORED FIRMLY TO THE OUTSIDE OF THE STRUCTURE.
- TYPE I DENOTES INLET WITH SINGLE THROAT AND CHAMBER. TYPE II DENOTES INLET WITH DOUBLE THROAT AND CHAMBER. TYPE III DENOTES INLET WITH SINGLE THROAT AND CHAMBER ADJACENT TO WALL OR BARRIER.
- MAXIMUM PIPE SIZE IS 24" DIAMETER.
- CONCRETE MEDIAN BARRIER (TALL WALL) SHALL HAVE DELINEATORS INSTALLED ON BARRIER WALL ORIENTED TOWARDS ONCOMING TRAFFIC AT APPROXIMATELY 25" ABOVE THE ROADWAY.
- PROVIDE SAFETY SLABS WHEN SPECIFIED ON THE PLANS.
- WHEN SPECIFIED ON THE PLANS, THE INVERT IS TO BE SHAPED IN ACCORDANCE WITH STANDARD IS-1. THE COST OF FURNISHING AND PLACING ALL MATERIALS INCIDENTAL TO THE SHAPING IS TO BE INCLUDED IN THE BID PRICE FOR THE STRUCTURE.

TYPE I & III INLET

REINFORCING STEEL

MARK	SIZE	NO.	LENGTH	SPACE
A SEE NOTE 9	#4	6 SEE NOTE 7	L - 2'-6" SEE NOTE 8	AS SHOWN
A-1 SEE NOTE 11	#4	(2XL)+2	5'-6"	12"
B SEE NOTE 9	#3	2X(L-4)	1'-1"	12"
B-1 SEE NOTE 11	#4	11	L + (2'-4")	8"
DOWELS	#4	SEE NOTE 6	1'-0"	6"
F SEE NOTE 9	#5	3 SEE NOTE 10	1'-6"	6"
H	#5	(4XH)+10	3'-2"	12"
H1	#5	(4XH)+8	2'-8"	10"

TYPE - II INLET

A-1	#4	(2XL)+2	5'-6"	12"
B-1	#4	11	L + (2'-4")	8"
H-2	#3	16 SEE NOTE 12	7'-8"	10"
V-1	#5	12	H - (1'-2")	8"
V-2	#4	30	LENGTH = H	8"
A SEE NOTE 15	#4	12 SEE NOTE 14	L - (2'-6") SEE NOTE 8	AS SHOWN
B SEE NOTE 15	#4	4(L-4)	1'-1"	12"
DOWELS	#3	DOUBLE NO. SHOWN FOR TYPE I	1'-0"	6"
F SEE NOTE 15	#5	6 SEE NOTE 13	1'-6"	6"
H	#5	(4 + H)+8	3'-2"	12"
H-1	#5	(4 + H)+16	2'-8"	10"
V	#4	30	LENGTH = H	8"
M-1	#5	5	3'-2"	5"
M	#4	4	1'-8"	12"

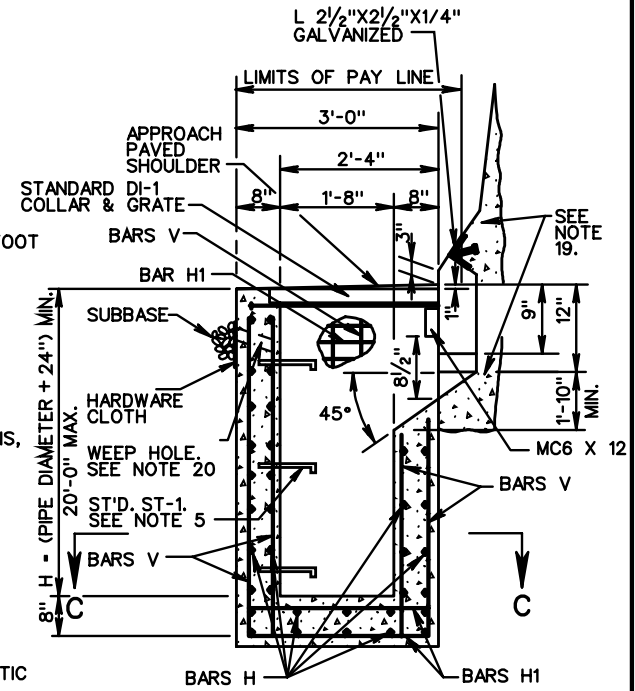
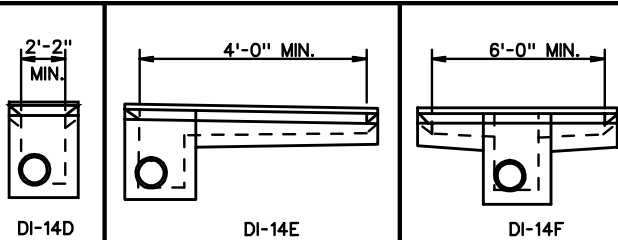

FOR USE ADJACENT TO WALL OR BARRIER WITH SAFETY SHAPE (TYPE III)



ROAD AND BRIDGE STANDARDS

SHEET 2 OF 2

REVISION DATE

104.41

CONCRETE MEDIAN BARRIER DROP INLET

12"-24" PIPE: DEPTH (H)=20' MAX.

VIRGINIA DEPARTMENT OF TRANSPORTATION

SPECIFICATION REFERENCE

233
302

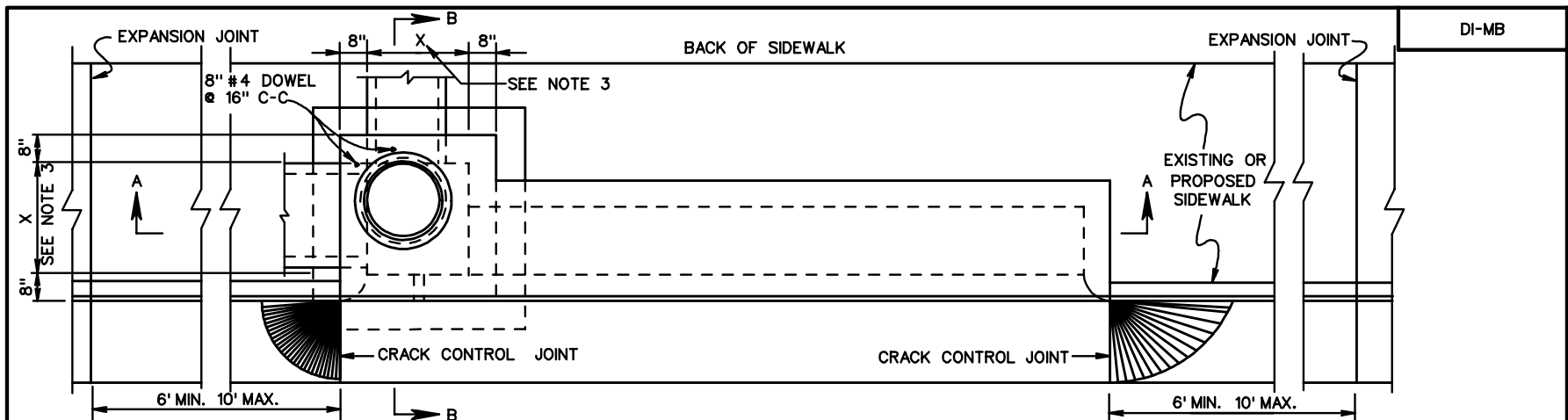

PLAN

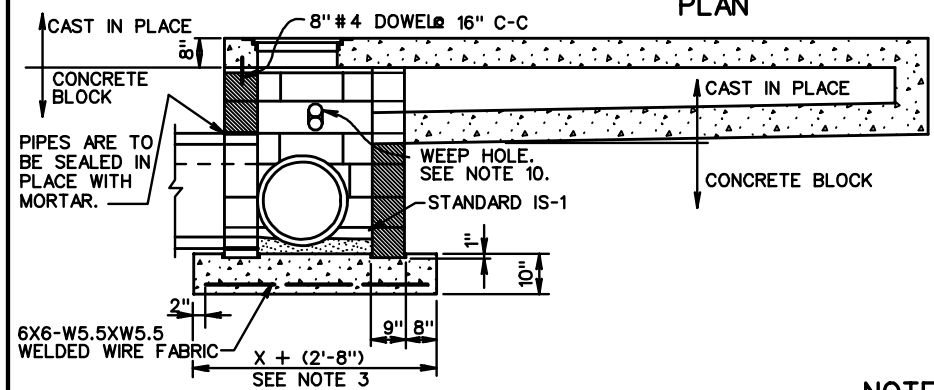

SECTION A-A

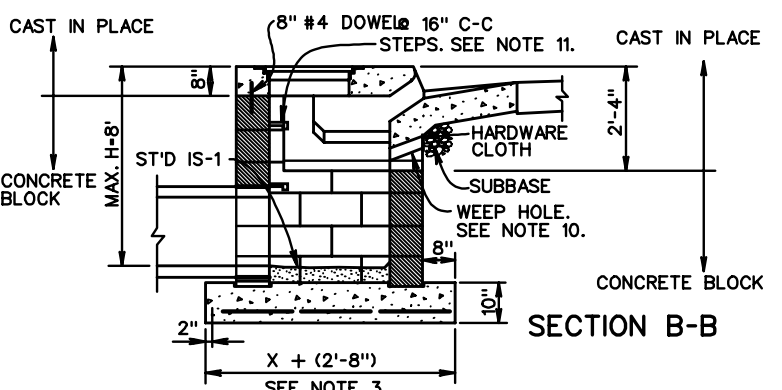

SECTION B-B

NOTES

1. CONCRETE BLOCK IS TO BE EITHER 8" X 8" X 16" OR 8" X 8" X 12" (NOMINAL DIMENSION) SOLID CONCRETE MASONRY BLOCK MEETING THE REQUIREMENTS OF ASTM C-139.
2. DETAILS ABOVE APPLY TO STANDARD DRAWINGS 3A THROUGH 3F AND 4A THROUGH 4F.
3. X EQUALS INTERIOR DIMENSION OF STANDARD DROP INLET SPECIFIED ON PLANS.
4. PARTIAL BLOCK, BRICK OR MORTAR MAY BE USED TO ADJUST TOP TO CURB ELEVATION.
5. REINFORCED CONCRETE FOOTING MAY BE PRECAST OR CAST IN PLACE. LIFTING HOOKS OF FABRICATORS DESIGN ARE TO BE PROVIDED IN PRECAST FOOTING.
6. MAXIMUM DEPTH ALLOWABLE FOR CONCRETE BLOCK CONSTRUCTION IS TO BE 8 FEET.
7. MORTAR JOINTS ON INTERIOR SURFACES ARE TO BE FINISHED FLUSH AND MAY BE LEFT EXTRUDED ON EXTERIOR FACES.
8. THE "H" DIMENSION SHOWN ON THE ST'D'S AND SPECIFIED ON THE PLANS WILL MEASURED FROM THE INVERT OF THE OUTFALL PIPE TO THE TOP OF THE STRUCTURE. PLAN "H" DIMENSIONS ARE APPROXIMATE ONLY FOR ESTIMATING PURPOSES AND THE ACTUAL DIMENSIONS SHALL BE DETERMINED BY THE CONTRACTOR BY FIELD CONDITIONS.
9. WHEN SPECIFIED ON THE PLANS THE INVERT IS TO BE SHAPED IN ACCORDANCE WITH STANDARD PLAN IS-1. THE COST OF FURNISHING AND PLACING ALL MATERIALS INCIDENTAL TO THE SHAPING IS TO BE INCLUDED IN THE BID PRICE FOR THE STRUCTURE.
10. 3" DIAMETER WEEP HOLE SHALL BE LOCATED TO DRAIN SUBBASE MATERIAL. WEEP HOLE WITH 12" X 12" PLASTIC HARDWARE CLOTH 1/4" MESH OR GALVANIZED STEEL WIRE, MINIMUM WIRE DIAMETER 0.03", NUMBER 4 MESH HARDWARE CLOTH ANCHORED FIRMLY TO THE OUTSIDE OF THE STRUCTURE.
11. ALL DETAILS AND DIMENSIONS OF THE PORTION OF THE INLET DESIGNATED "CAST-IN-PLACE" ARE TO BE IN STRICT ACCORDANCE WITH THE ST'D. DRAWING SPECIFIED ON THE PLANS. THIS WILL INCLUDE ALL NOTES, DETAILS OF FRAME AND COVER, GUTTER, AND ANGLE IRON. ALL REINF. STEEL WILL REMAIN AS DETAILED WITH THE FOLLOWING EXCEPTIONS:
 - A) THE VERTICAL LEG OF BARS C WILL BE ELIMINATED.
 - B) BARS G WILL BE ELIMINATED AND REPLACED WITH DOWELS SHOWN HEREON.
12. IN THE EVENT THE INVERT OF THE OUTFALL PIPE IS HIGHER THAN THE BOTTOM OF THE STRUCTURE, THE INVERT OF THE STRUCTURE SHALL BE SHAPED WITH CEMENT MORTAR TO PREVENT STANDING OR PONDING OF WATER IN THE STRUCTURE. THE COST OF FURNISHING AND PLACING ALL MATERIALS INCIDENTALS TO THE SHAPING IS TO BE INCLUDED IN THE BID PRICE FOR THE STRUCTURE.
13. STEPS ARE TO BE PROVIDED WHEN H IS 4'-0" OR GREATER. FOR DETAILS SEE STANDARD ST-1.

SPECIFICATION REFERENCE
302

CONSTRUCTION METHOD FOR CONCRETE MASONRY BLOCK CURB DROP INLET

VIRGINIA DEPARTMENT OF TRANSPORTATION

VDOT	
ROAD AND BRIDGE STANDARDS	
REVISION DATE	SHEET 1 OF 1
104.42	

THIS PAGE INTENTIONALLY LEFT BLANK



ROAD AND BRIDGE STANDARDS

SHEET 1 OF 1

REVISION DATE

104.43

VIRGINIA DEPARTMENT OF TRANSPORTATION

SPECIFICATION
REFERENCE

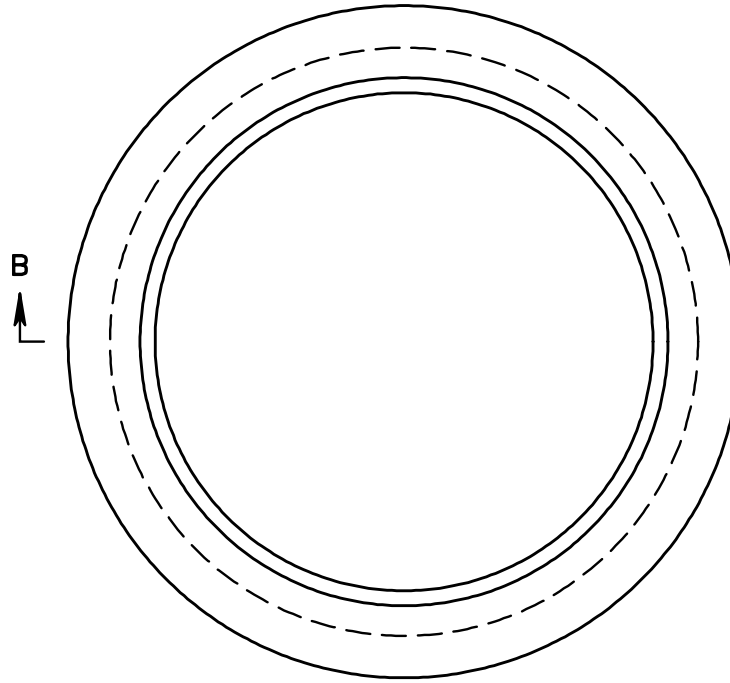

FRAME

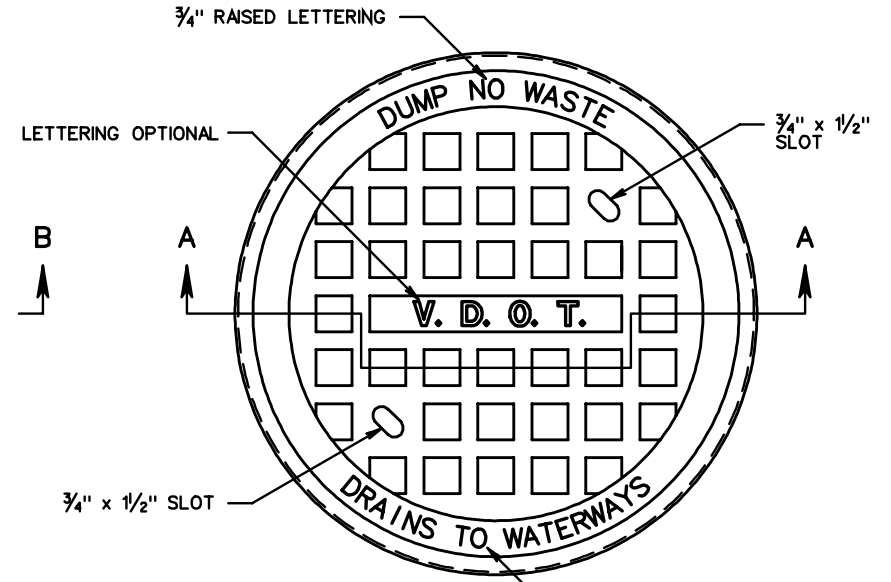

COVER

APPROXIMATE WEIGHT
CAST IRON
FRAME 86 ± 4 LBS.
COVER 83 ± 4 LBS.

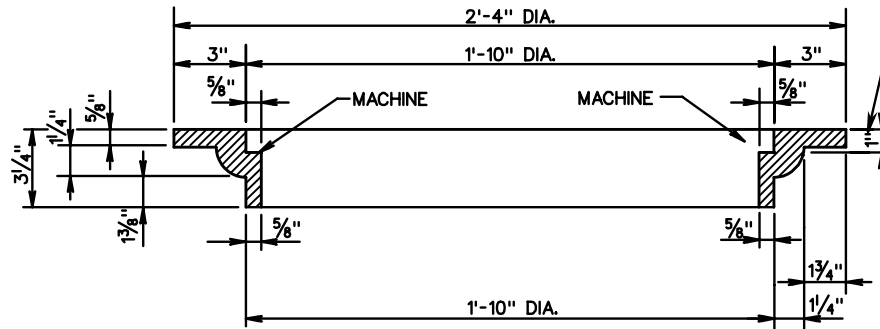

SECTION B-B

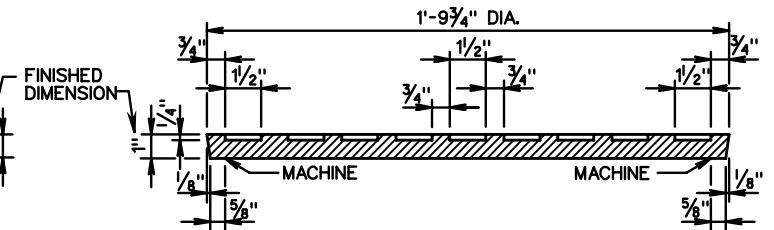

SECTION A-A

NOTES

1. THE LETTERS V.D.O.T. ARE OPTIONAL, IF USED THE LETTERS ARE TO BE CAST IN THE DEPRESSION IN TOP OF THE COVER 1" WIDE AND RAISED 1/4" HIGH AS SHOWN.
2. THE DUMP NO WASTE DRAINS TO WATERWAYS LETTERING IS REQUIRED ON ALL IC-2 COVERS. LOCATION OF LETTERING MAY VARY BY MANUFACTURER.

SPECIFICATION
REFERENCE

224
302

STANDARD INLET AND FRAME COVER

VIRGINIA DEPARTMENT OF TRANSPORTATION

VDOT

ROAD AND BRIDGE STANDARDS

REVISION DATE

SHEET 1 OF 3

105.01

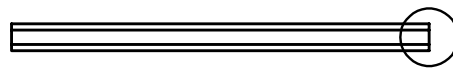
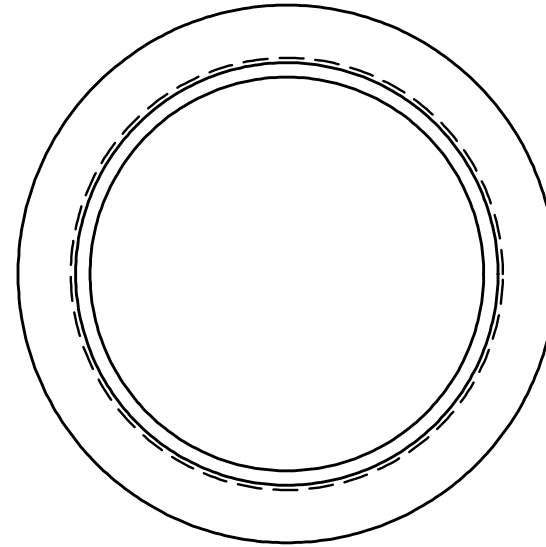
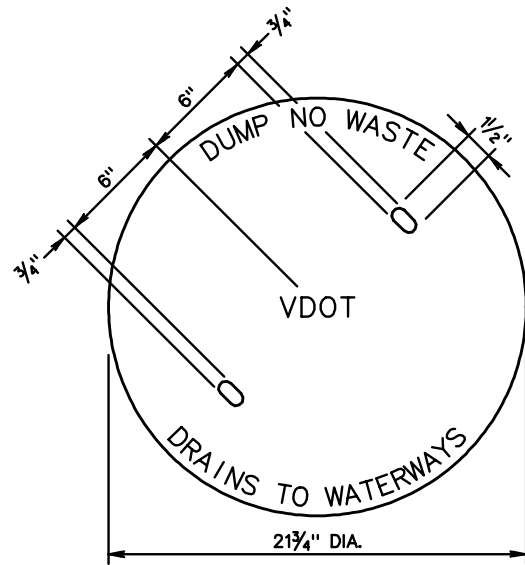

INLET COVER

SEE
DETAIL A

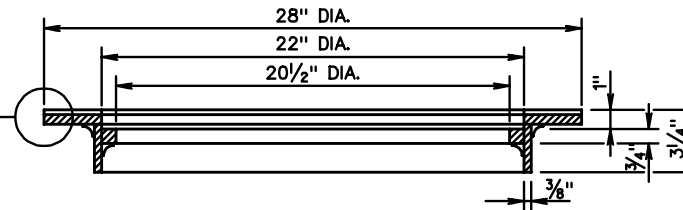

SECTION ϕ
INLET FRAME

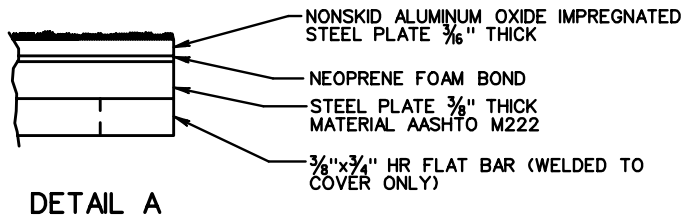

DETAIL A

NOTES

1. STRUCTURAL COMPONENTS SHALL CONFORM TO AASHTO M222.
2. FRAME AND COVER SHALL HAVE A CONTINUOUS FLASH FIT.
3. DUMP NO WASTE DRAINS TO WATERWAYS LETTERING IS REQUIRED ON ALL IC-2 COVERS. LOCATION OF LETTERING MAY VARY BY MANUFACTURER.



ROAD AND BRIDGE STANDARDS

SHEET 2 OF 3

REVISION DATE

105.02

STANDARD INLET FRAME AND COVER

VIRGINIA DEPARTMENT OF TRANSPORTATION

SPECIFICATION
REFERENCE

302

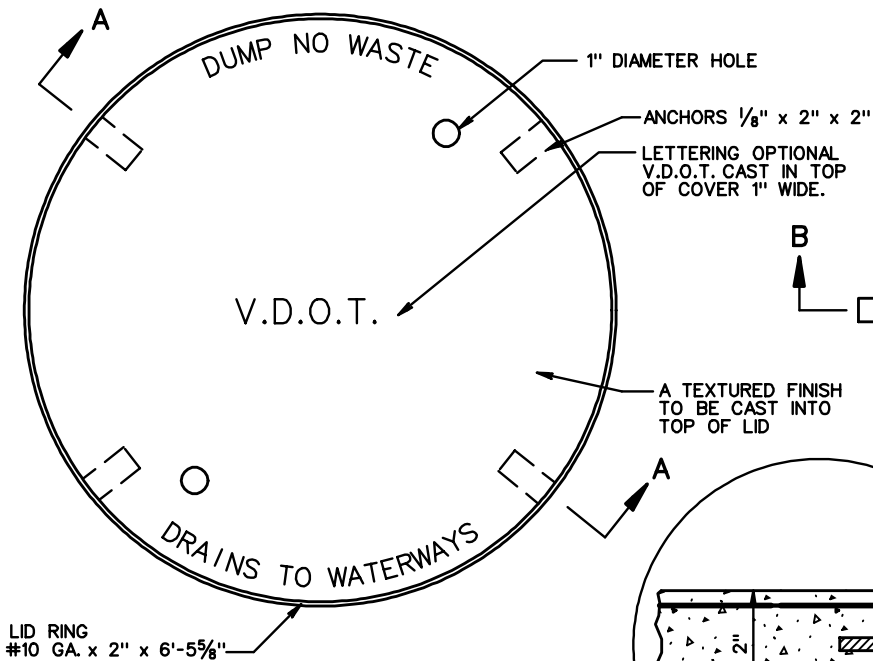

PLAN VIEW COVER

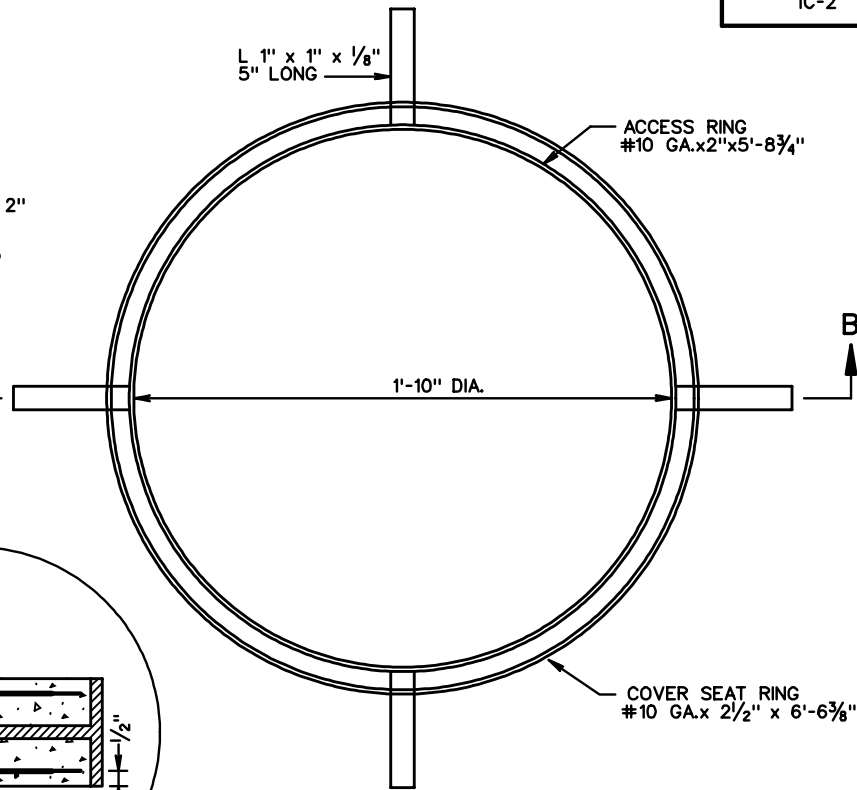

PLAN VIEW FRAME

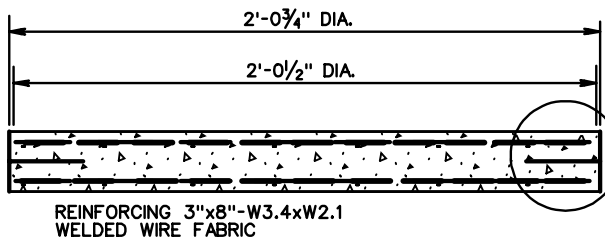

SECTION A-A

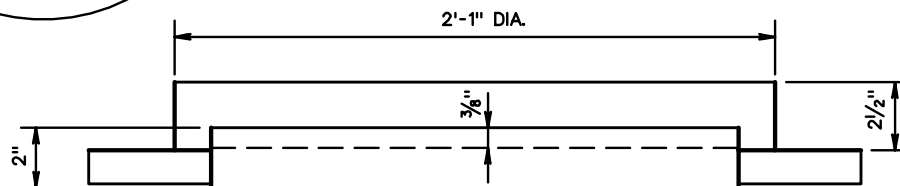

SECTION B-B

NOTES

1. CONCRETE 4000 PSI
2. SUPPLIER MAY FURNISH $\frac{1}{8}$ " STEEL FOR 10 GA.
3. ALL METAL GALVANIZED TO V.D.O.T. STANDARD AND ASTM A 123-73.
4. DUMP NO WASTE DRAINS TO WATERWAYS LETTERING IS REQUIRED ON ALL IC-2 COVERS.
LOCATION OF LETTERING MAY VARY BY MANUFACTURER.

SPECIFICATION
REFERENCE

105
302

PRECAST INLET AND FRAME COVER

VIRGINIA DEPARTMENT OF TRANSPORTATION

VDOT

ROAD AND BRIDGE STANDARDS

REVISION DATE

SHEET 3 OF 3

105.03

THIS PAGE INTENTIONALLY LEFT BLANK



ROAD AND BRIDGE STANDARDS

SHEET 1 OF 1

REVISION DATE

105.04

VIRGINIA DEPARTMENT OF TRANSPORTATION

SPECIFICATION
REFERENCE

SEE STANDARD SL-1 FOR APPLICABILITY OF SAFETY SLABS.

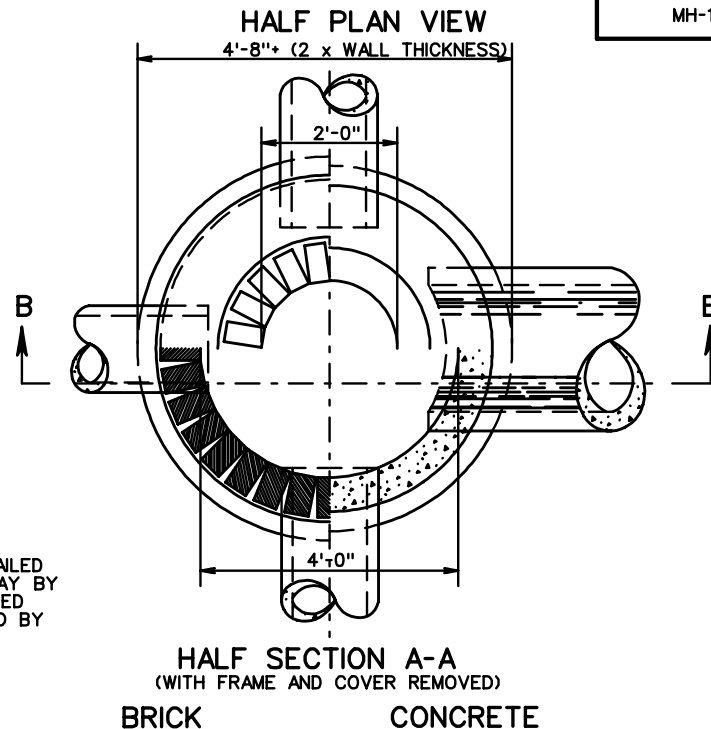
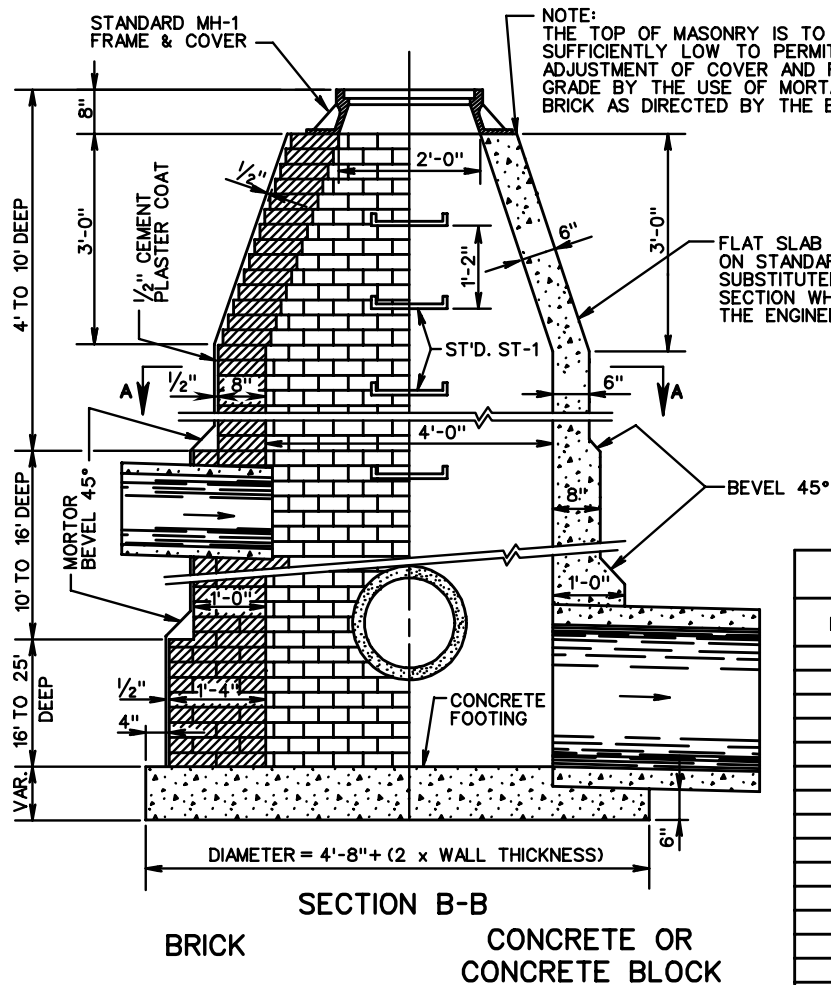

NOTES:

1. QUANTITIES SHOWN ARE FOR MANHOLE WITHOUT PIPES. THE AMOUNT DISPLACED BY PIPES MUST BE DEDUCTED TO OBTAIN TRUE QUANTITIES.
2. A BASE THICKNESS OF 9" WAS USED IN COMPUTING CONCRETE QUANTITIES.
3. INCREMENTS TO BE ADDED FOR EACH ADDITIONAL FOOT OF DEPTH.
4. MATERIALS MAY BE BRICK, CONCRETE OR APPROVED CONCRETE MANHOLE BLOCK.
5. IF BLOCKS ARE USED THE MINIMUM THICKNESS OF SAME IS TO BE 5". OTHER THICKNESSES ARE TO CONFORM TO WALL THICKNESS SHOWN FOR CONCRETE.
6. ALL CONCRETE TO BE CLASS A3.
7. WHEN SPECIFIED ON PLANS THE INVERT IS TO BE SHAPED IN ACCORDANCE WITH STANDARD IS-1. THE COST OF FURNISHING AND PLACING ALL MATERIALS INCIDENTAL TO THE SHAPING IS TO BE INCLUDED IN THE BID PRICE FOR THE STRUCTURE.

DEPTH	BRICK	MANHOLE	CONCRETE
FEET	THOUSANDS	CONCRETE	CONCRETE
		CU. YARDS	CU. YARDS
4	0.5	0.785	1.437
5	0.7	0.785	1.699
6	0.9	0.785	1.961
7	1.0	0.785	2.223
8	1.2	0.785	2.485
9	1.4	0.785	2.747
10	1.6	0.785	3.009
11	1.9	0.970	3.455
12	2.2	0.970	3.817
13	2.5	0.970	4.179
14	2.8	0.970	4.541
15	3.1	0.970	4.903
16	3.4	0.970	5.265
17	4.0	1.173	6.032
INCREMENT	0.45	-	0.582

SPECIFICATION REFERENCE

302

MANHOLE FOR 12" - 48" PIPE CULVERTS

VIRGINIA DEPARTMENT OF TRANSPORTATION



ROAD AND BRIDGE STANDARDS

REVISION DATE

SHEET 1 OF 5

106.01

MH-1

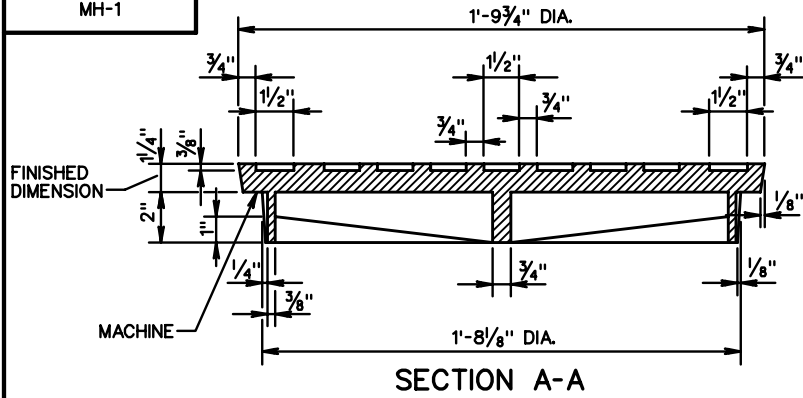

THE LETTERS V.D.O.T. ARE OPTIONAL
IF USED THE LETTERS ARE TO BE
CAST IN THE DEPRESSION IN TOP OF
COVER 1\"/>

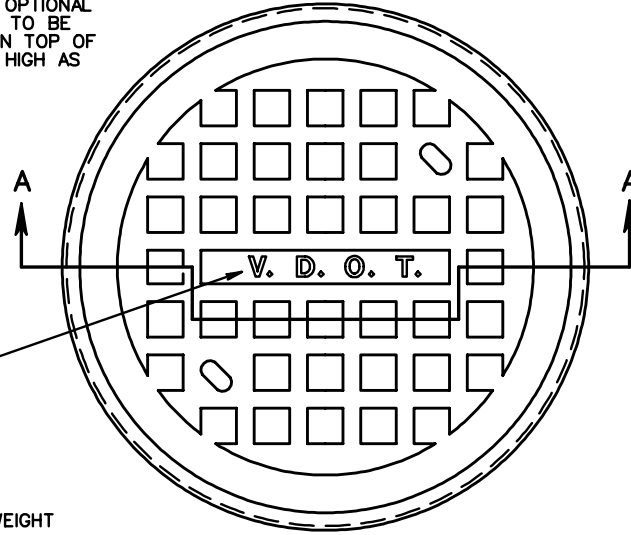

LETTERING
OPTIONAL

APPROXIMATE WEIGHT
CAST IRON
FRAME 239 ± 12 LBS.
COVER 137 ± 7 LBS.

TOP

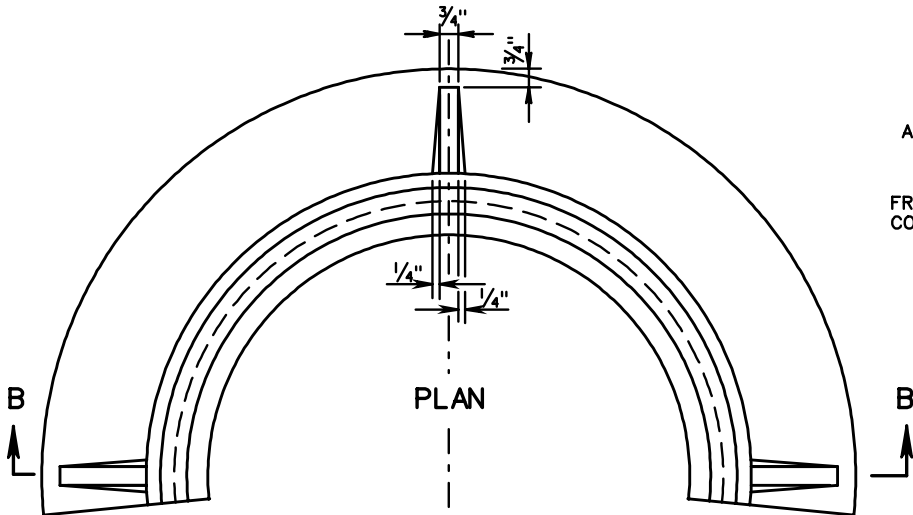

PLAN

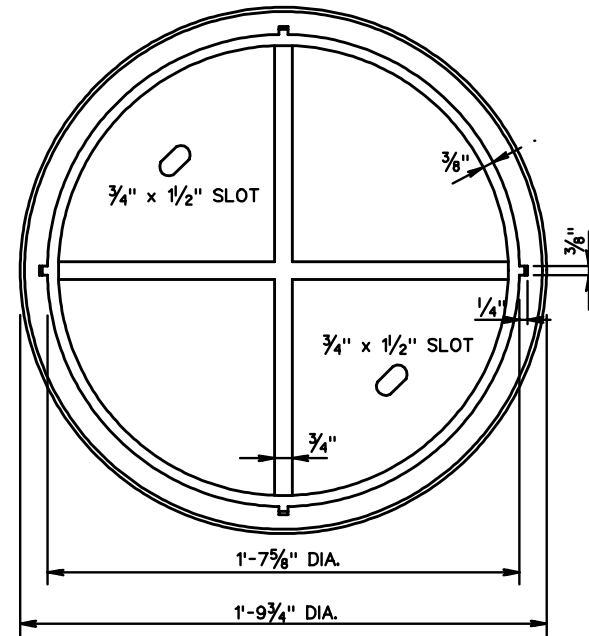

BOTTOM

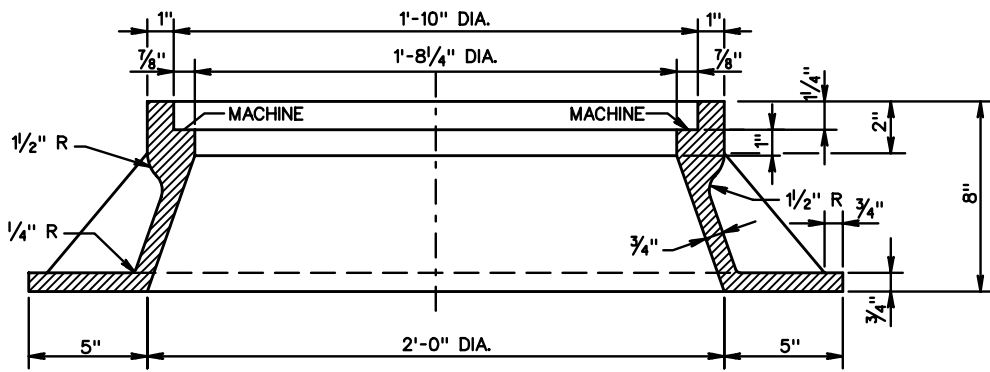

SECTION B-B



ROAD AND BRIDGE STANDARDS

SHEET 2 OF 5

REVISION DATE

106.02

STANDARD MANHOLE FRAME AND COVER

VIRGINIA DEPARTMENT OF TRANSPORTATION

SPECIFICATION
REFERENCE

224
302

NOTES:
 THE LETTERS V.D.O.T. ARE OPTIONAL,
 IF USED THE LETTERS ARE TO BE
 CAST IN THE DEPRESSION IN TOP OF
 COVER 1" WIDE AND RAISED $\frac{3}{8}$ " HIGH
 AS SHOWN.

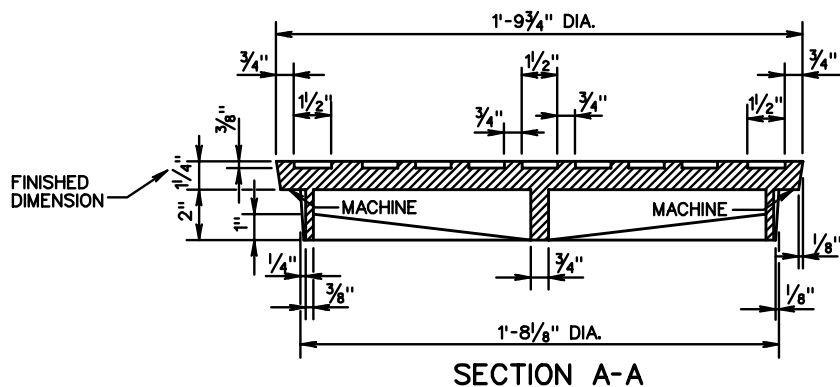

LETTERING
 OPTIONAL

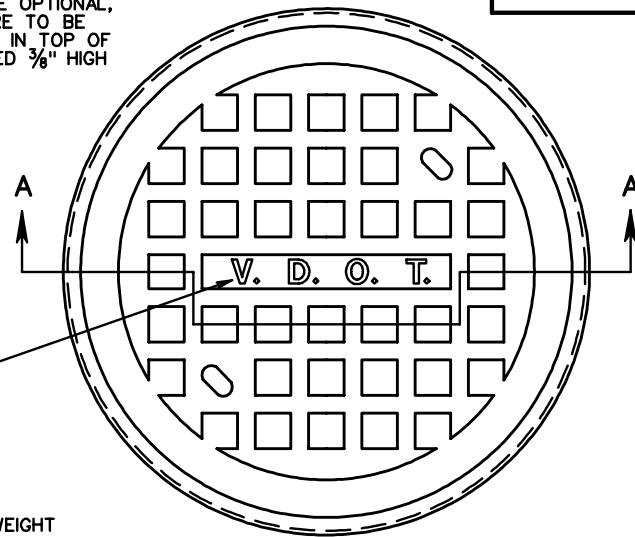

TOP

APPROXIMATE WEIGHT
 CAST IRON
 COVER 137 ± 7 LBS.
 FRAME 235 ± 12 LBS.

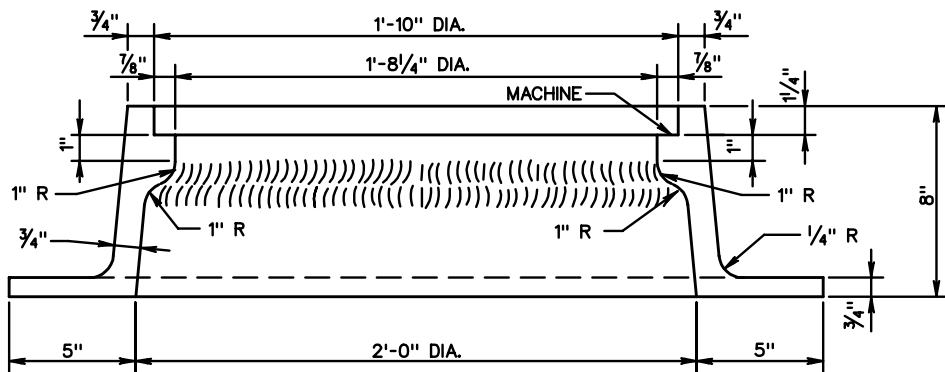

FRAME SECTION AT MID POINT

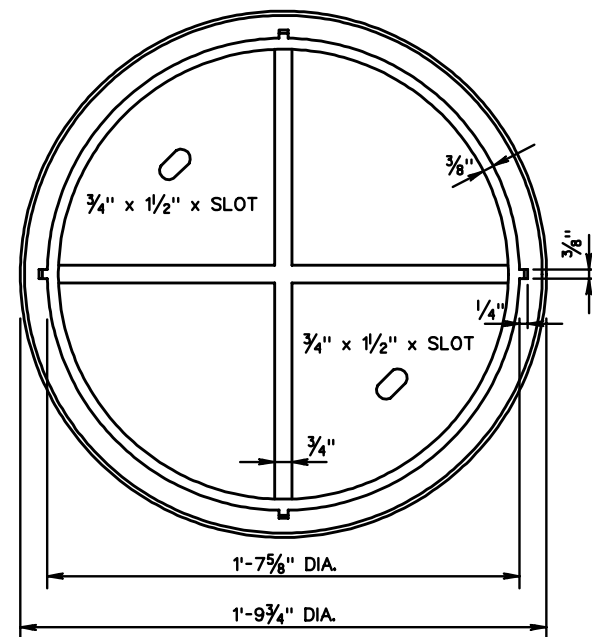

BOTTOM

SPECIFICATION
 REFERENCE

224
 302

STANDARD MANHOLE FRAME AND COVER

VIRGINIA DEPARTMENT OF TRANSPORTATION

VDOT

ROAD AND BRIDGE STANDARDS

REVISION DATE

SHEET 3 OF 5

106.03

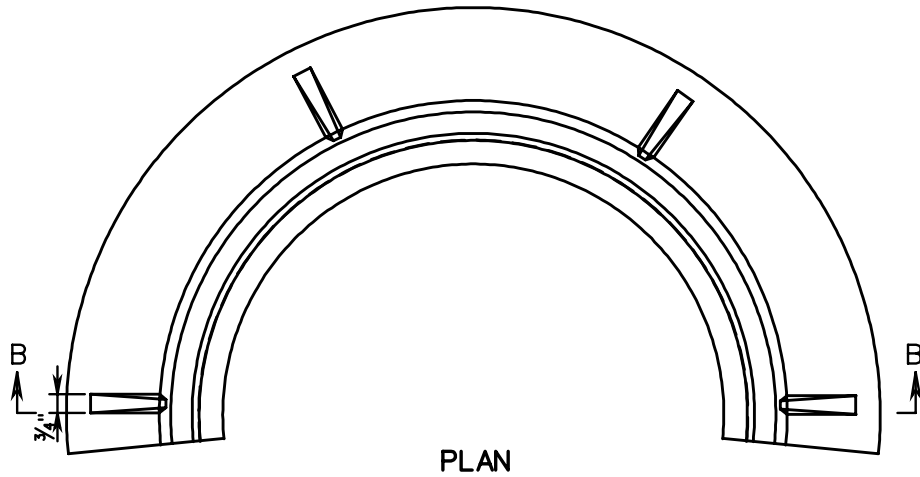

PLAN

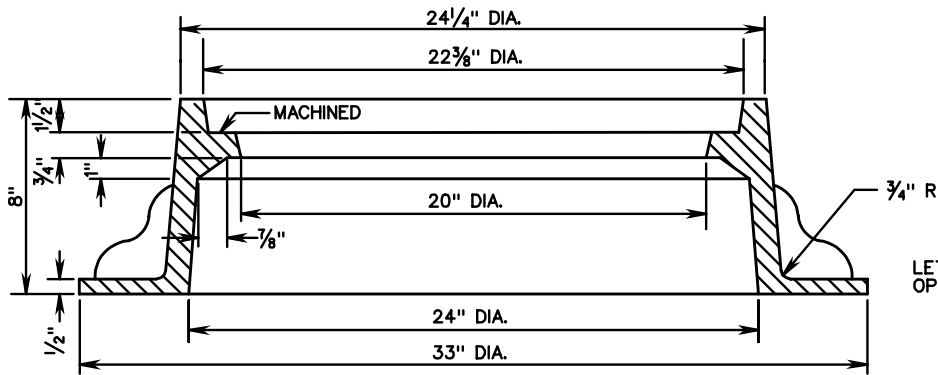

FRAME

EITHER COVER A OR B MAY BE USED WITH FRAME.
APPROX. WEIGHT COVER 170 LBS. ±

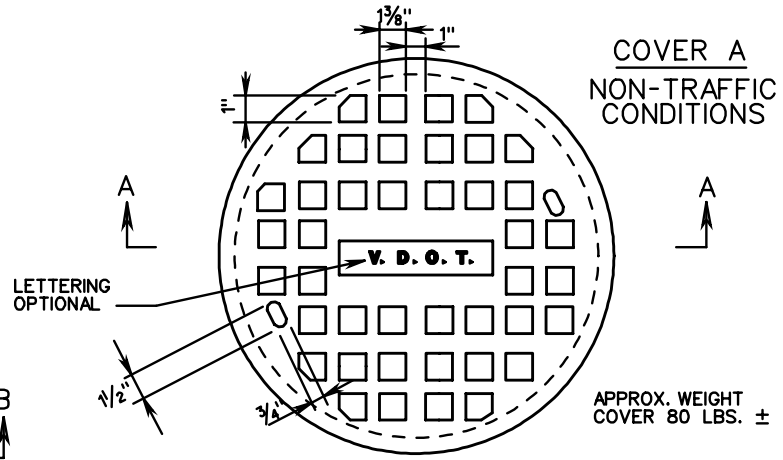

COVER A
NON-TRAFFIC
CONDITIONS

APPROX. WEIGHT COVER 80 LBS. ±

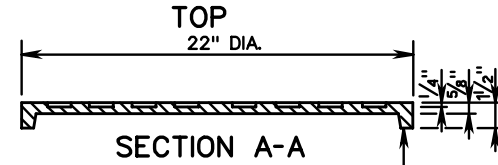

SECTION A-A

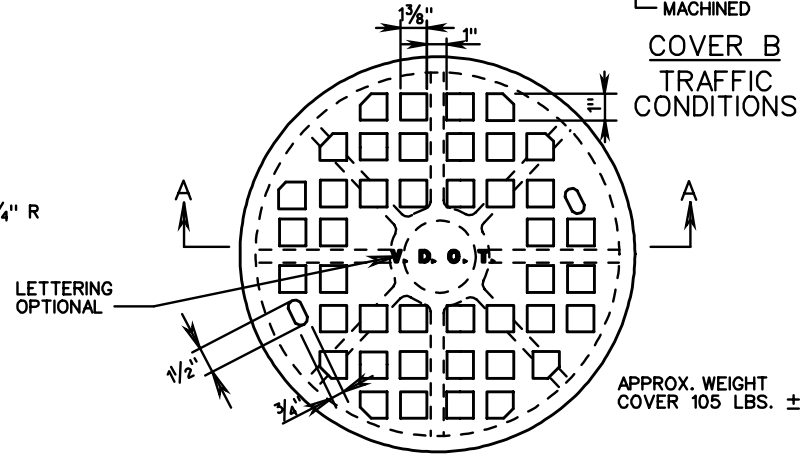

COVER B
TRAFFIC
CONDITIONS

APPROX. WEIGHT COVER 105 LBS. ±

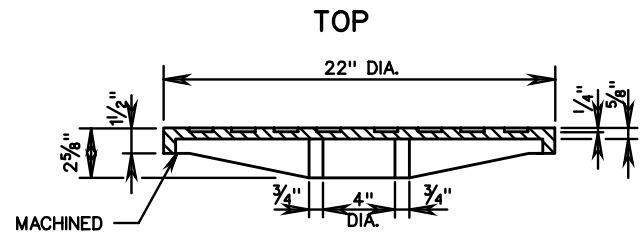

SECTION A-A



ROAD AND BRIDGE STANDARDS

SHEET 4 OF 5

REVISION DATE

106.04

STANDARD MANHOLE FRAME AND COVER

VIRGINIA DEPARTMENT OF TRANSPORTATION

SPECIFICATION
REFERENCE

224
302

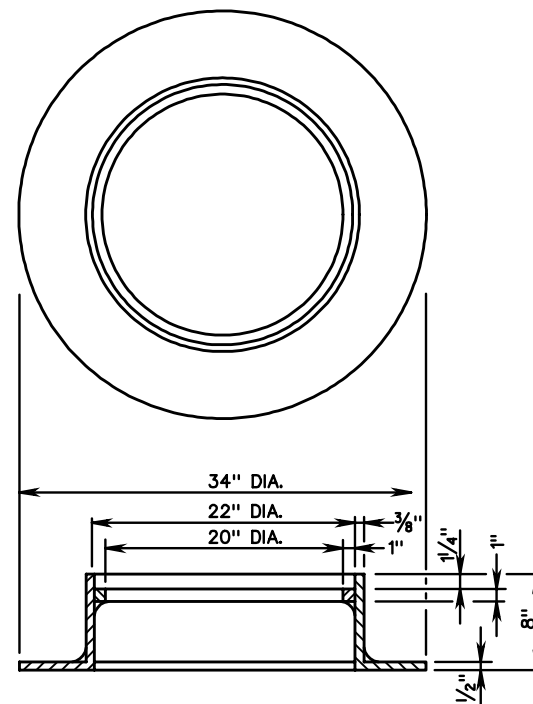
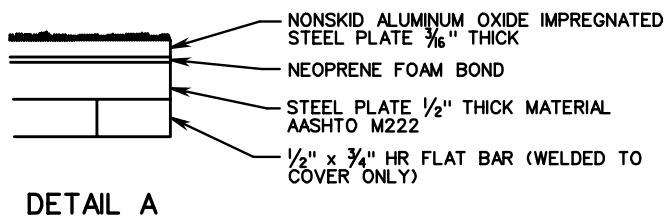
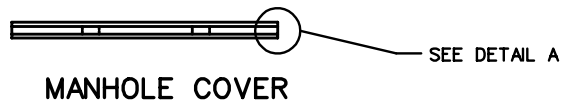
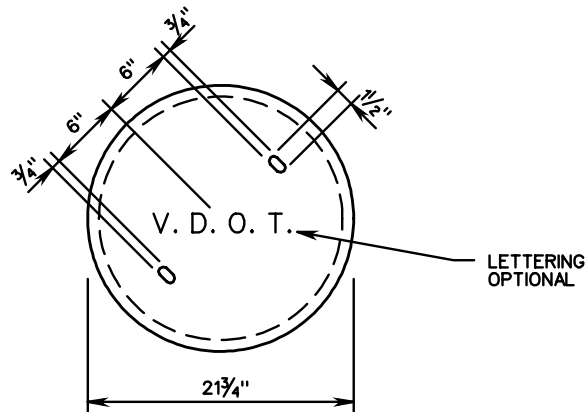

NOTES:
 STRUCTURAL COMPONENTS SHALL CONFORM TO AASHTO M222.
 FRAME AND COVER SHALL HAVE A CONTINUOUS FLUSH FIT.

SPECIFICATION REFERENCE
302

STANDARD MANHOLE AND COVER
 VIRGINIA DEPARTMENT OF TRANSPORTATION

VDOT ROAD AND BRIDGE STANDARDS	
REVISION DATE	SHEET 5 OF 5
	106.05

NOTES:
 THE LETTERS V.D.O.T. ARE OPTIONAL,
 IF USED THE LETTERS ARE TO BE
 CAST IN THE DEPRESSION IN TOP OF
 COVER 1" WIDE AND RAISED $\frac{3}{8}$ " HIGH
 AS SHOWN.

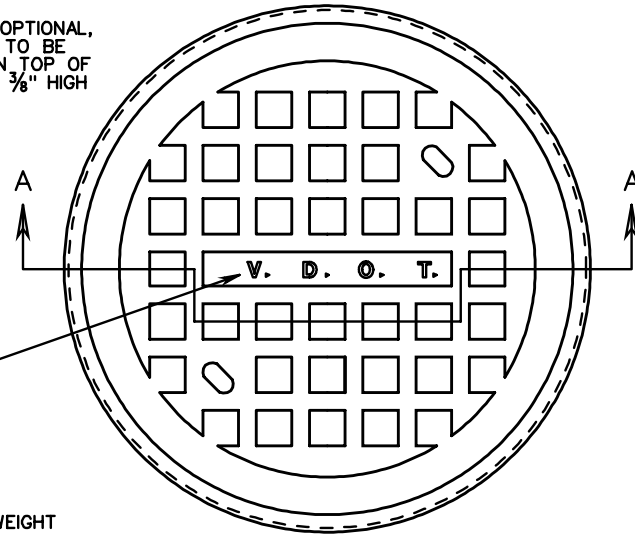
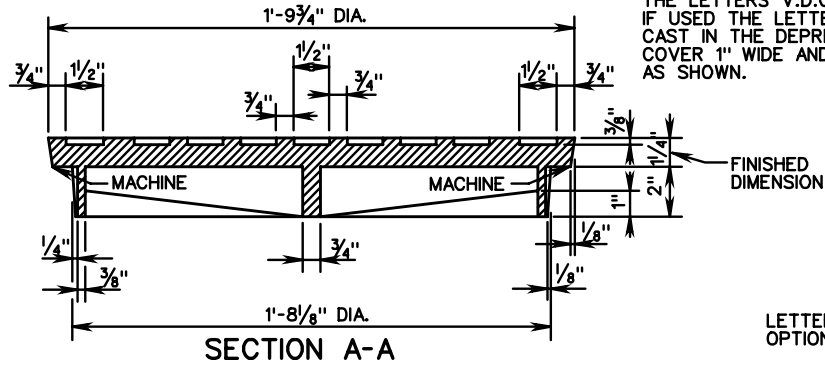

APPROXIMATE WEIGHT
 CAST IRON
 FRAME 174 ± 9 LBS.
 COVER 137 ± 7 LBS.

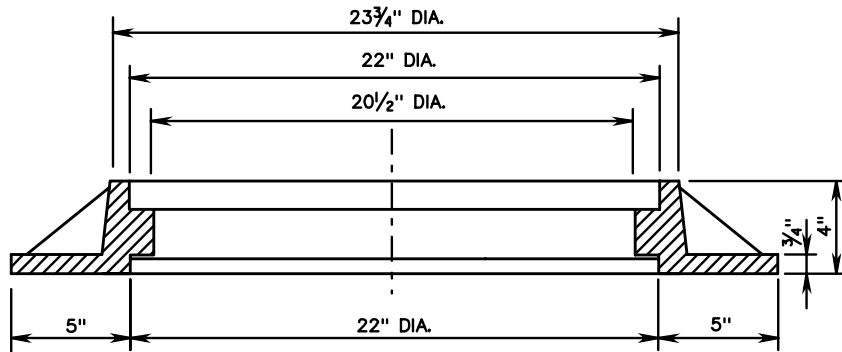
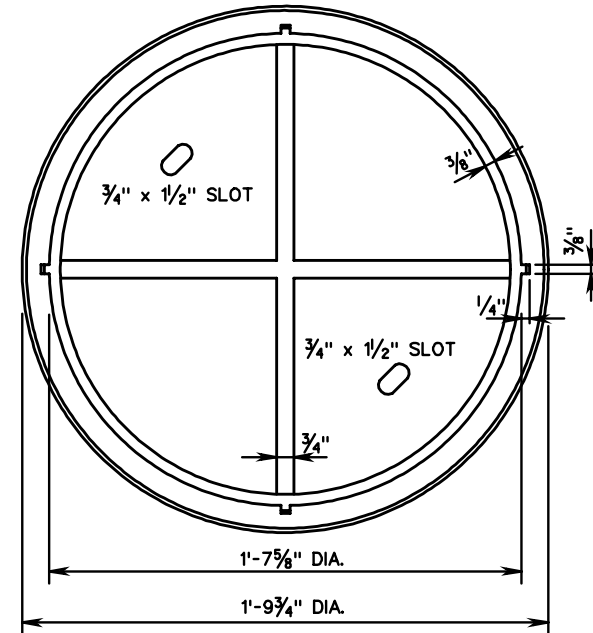
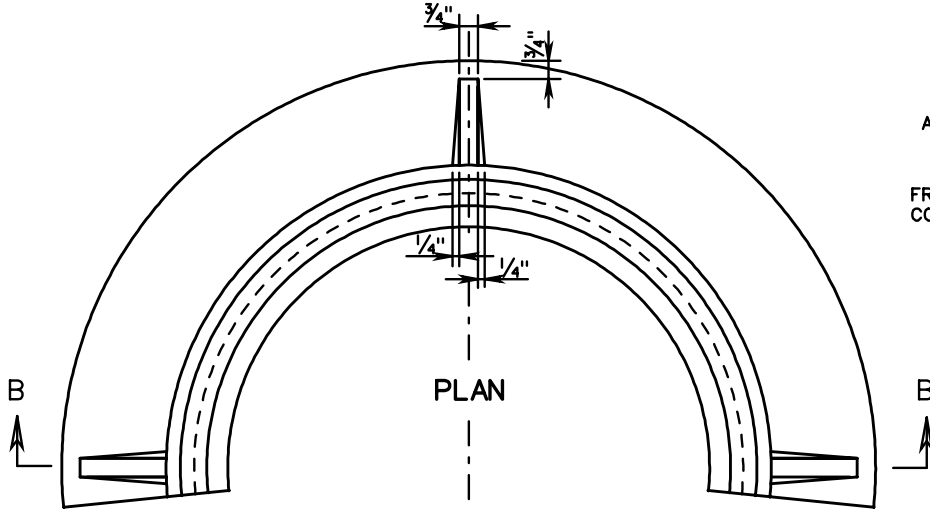

SECTION B-B



ROAD AND BRIDGE STANDARDS

SHEET 1 OF 1

REVISION DATE

106.06

STANDARD MANHOLE FRAME AND COVER

VIRGINIA DEPARTMENT OF TRANSPORTATION

SPECIFICATION
 REFERENCE

224
 302

FOR DETAILS OF ALL COMPONENT PARTS AND
 "GENERAL NOTES- PRECAST" SEE SHEETS
 103.01-103.11

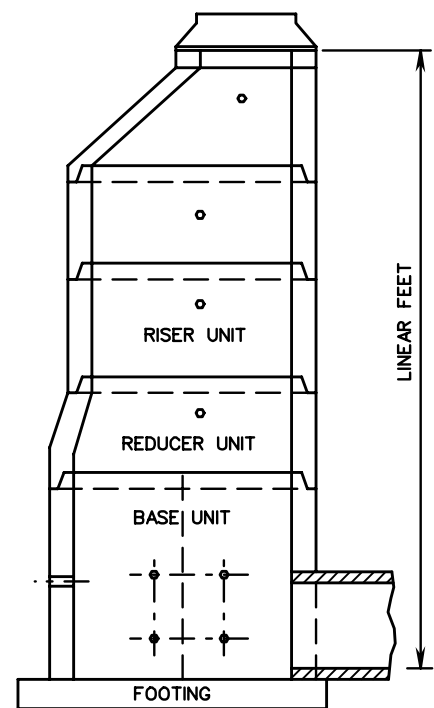
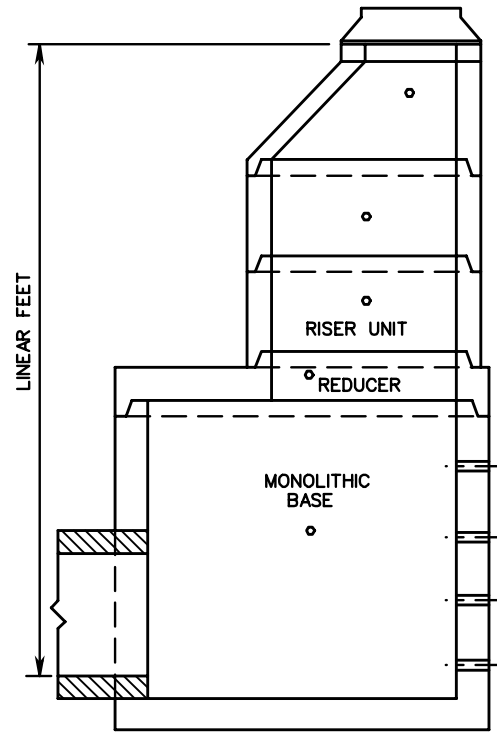
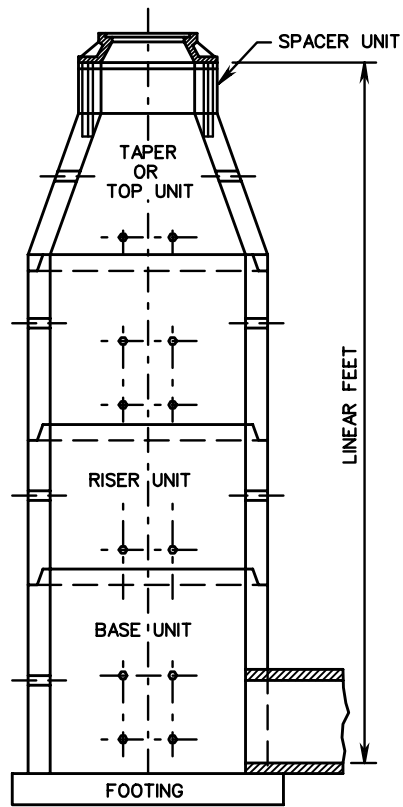

SPECIFICATION REFERENCE
105 302

PRECAST MANHOLE
 VIRGINIA DEPARTMENT OF TRANSPORTATION

VDOT	
ROAD AND BRIDGE STANDARDS	
REVISION DATE	SHEET 1 OF 1
	106.07

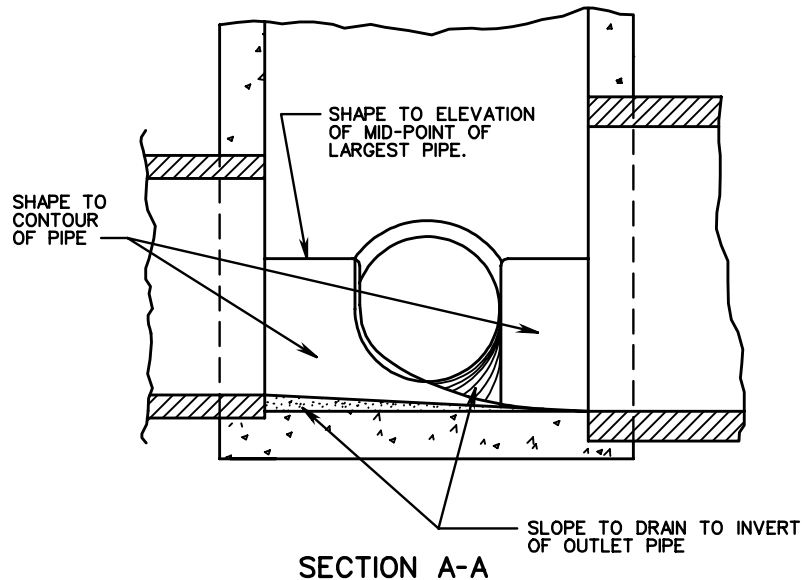
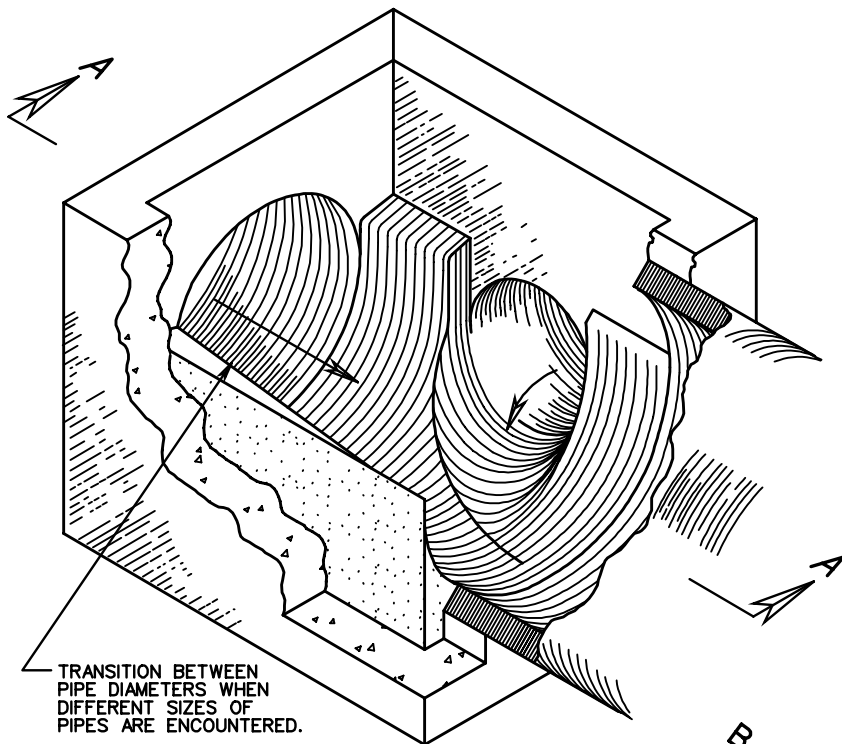

METHOD OF TREATMENT IN DROP INLETS

NOTES:
SHAPING OF MANHOLE AND INLET INVERTS IN ACCORDANCE WITH THIS DRAWING IS TO APPLY TO THOSE STRUCTURES SPECIFIED ON PLANS OR WHERE INVERT OF PIPE IS ABOVE INVERT OF STRUCTURE.

MANHOLE OR DROP INLET IS TO BE FORMED AND CONSTRUCTED IN ACCORDANCE WITH APPLICABLE STANDARD OR SPECIAL DRAWING. THE INVERT SHAPING AS DETAILED HEREON IS TO CONSIST OF A PORTLAND CEMENT CONCRETE MIX CONFORMING TO CLASS A3 OR CLASS C1, EXCEPT THAT 25% OF COARSE AGGREGATE MAY BE UP TO 4" IN DIAMETER AND CONSIST OF STONE, BROKEN BRICK, BROKEN CONCRETE OR BROKEN CONCRETE BLOCK. THE SURFACE SHALL BE LEFT SMOOTH BY MEANS OF HAND TROWELLING. NONE OF THE COARSE AGGREGATE SHALL REMAIN EXPOSED.

DETAILS OF INVERT SHAPING AS SHOWN HEREON ARE FOR EXAMPLE PURPOSES ONLY. EACH MANHOLE OR DROP INLET IS TO BE SHAPED INDIVIDUALLY TO BEST FIT THE PARTICULAR INLET AND OUTLET CONFIGURATION AND FLOW LINES.

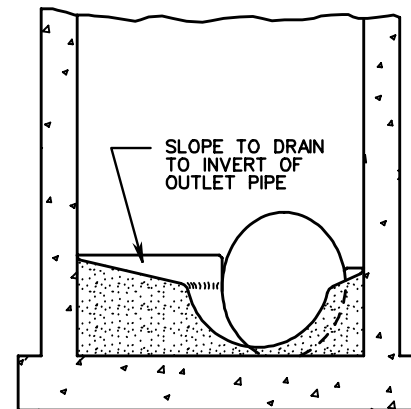
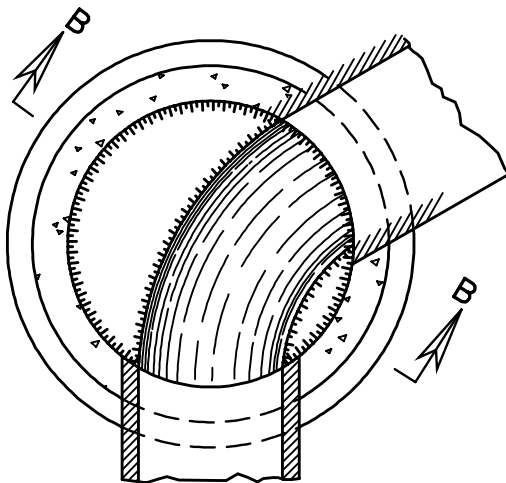

METHOD OF TREATMENT IN MANHOLES



ROAD AND BRIDGE STANDARDS

SHEET 1 OF 1

REVISION DATE

106.08

STANDARD METHOD OF SHAPING MANHOLE & INLET INVERTS

VIRGINIA DEPARTMENT OF TRANSPORTATION

SPECIFICATION
REFERENCE

302

NO. 6 GALVANIZED STEEL STEP

#4, GRADE 60, REINFORCING ROD ENCASED IN A CORROSION RESISTANT RUBBER OR OTHER MATERIAL APPROVED BY THE ENGINEER. (DIMENSION MAY VARY WITH MANUFACTURER'S DESIGN)

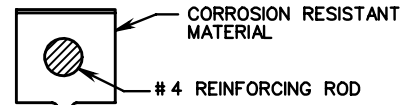

TYPICAL SECTION

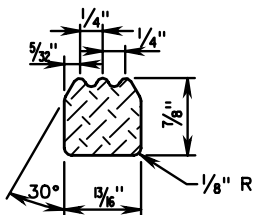
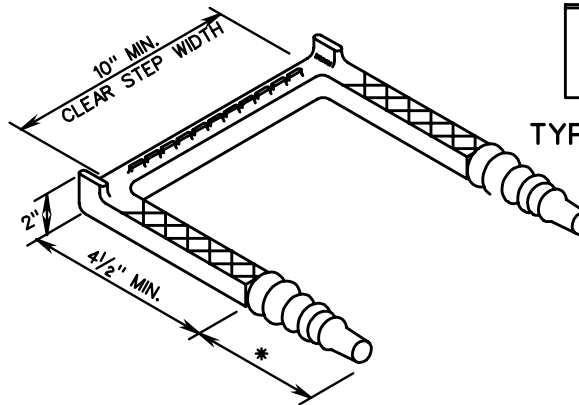
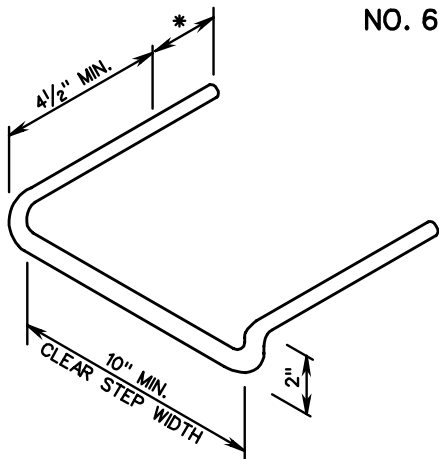

TYPICAL SECTION
(DIMENSIONS MAY VARY WITH MANUFACTURER'S DESIGN)

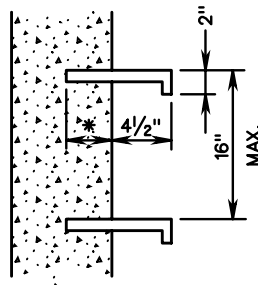

* MINIMUM OF 3" EMBEDMENT

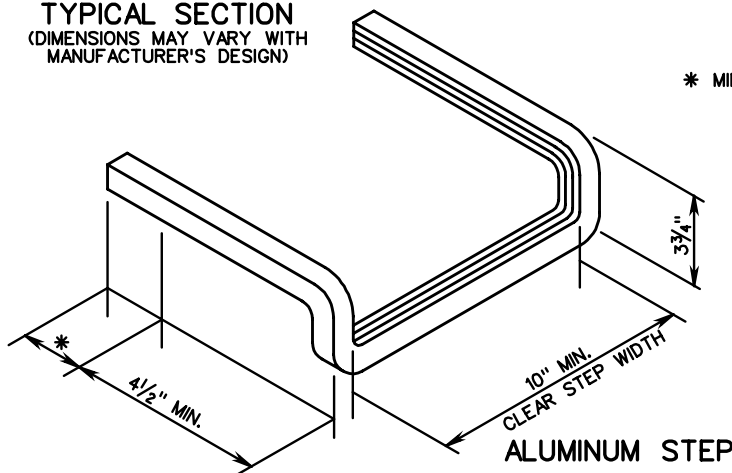

ALUMINUM STEP

NOTES:
STEPS WILL BE REQUIRED IN ALL STRUCTURES WITH A DEPTH OF 4'-0" OR GREATER UNLESS OTHERWISE NOTED ON THE PLANS.

ALL STEPS SHALL PROTRUDE 4 1/2" FROM INSIDE FACE OF STRUCTURE WALL.

MAXIMUM STEP SPACING TO BE 16" C-C.

STEPS SHALL WITHSTAND A MINIMUM FORCE OF 300 POUNDS WHEN EXTENDED 4 1/2" FROM THE FACE OF THE SUPPORT.

STEPS ARE TO BE VERTICALLY ALIGNED AND UNIFORMALLY SPACED FOR THE ENTIRE DEPTH OF ANY STRUCTURE.

IN PRECAST UNITS STEPS MAY BE CAST IN PLACE, MORTARED INTO HOLES PROVIDED BY THE FABRICATOR, OR DRIVEN.

STEPS DIFFERING IN DIMENSIONS, CONFIGURATION, OR MATERIALS FROM THOSE SHOWN MAY ALSO BE USED PROVIDED THEY MEET THE MINIMUM REQUIREMENTS SHOWN HEREON AND THE CONTRACTOR HAS FURNISHED THE ENGINEER WITH DETAILS AND CERTIFIED TEST REPORTS OF THE PROPOSED SUBSTITUTE AND HAS RECEIVED WRITTEN APPROVAL FROM THE ENGINEER FOR THE USE OF SUCH STEPS.

ALL STEPS INSTALLED SHALL BE PROVIDED WITH SLIP-RESISTANT SURFACES SUCH AS BUT NOT LIMITED TO, CORRUGATED KNURLED, OR DIMPLED SURFACES.

ALUMINUM STEPS SHALL BE FABRICATED IN ACCORDANCE WITH ASTM B221, ALLOY 6005-T5. THAT PORTION OF THE STEP ENCASED IN MASONRY SHALL BE UNIFORMLY COATED WITH A BITUMINOUS, SOLVENT TYPE, ASBESTOS FILLED ALUMINUM PIGMENTED COATING CONFORMING TO FEDERAL SPECIFICATION TC-C-00498A.

SPECIFICATION REFERENCE

STANDARD STEP

VIRGINIA DEPARTMENT OF TRANSPORTATION

VDOT

ROAD AND BRIDGE STANDARDS

REVISION DATE

SHEET 1 OF 1

106.09

JB-1

B

OPENING IN TOP SLAB OF CHAMBER TO BE CIRCULAR WHEN USED WITH TYPE A OR C TOWERS

TWO BARS K TO BE USED IN EACH CORNER WITH CIRCULAR OPENING IN TOP.
1 BAR F E.F.-E.S.

GALVANIZED S5X10 TO BE PLACED UNDER TOP SLAB AND EXTENDED INTO SIDE WALLS TO WITHIN 2" OF OUTSIDE FACE.

(BARS A @ 8" C-C N.F.
BARS G @ 8" C-C F.F.)

BARS J @ 6" C-C E.F.

"W" DENOTES BOTH THE INTERNAL CHAMBER WIDTH ALONG THE NARROW AXIS AND THE DIMENSION OF THE OPENING IN THE TOP SLAB OF CHAMBER

OPENING IN TOP SLAB OF CHAMBER TO BE SQUARE WHEN USED WITH TYPE B TOWERS

B

PLAN VIEW

(TOP SLAB REINFORCEMENT)

TYPE A, B, AND C TOWER. SEE SHEET 3 OF 4 FOR DETAILS.

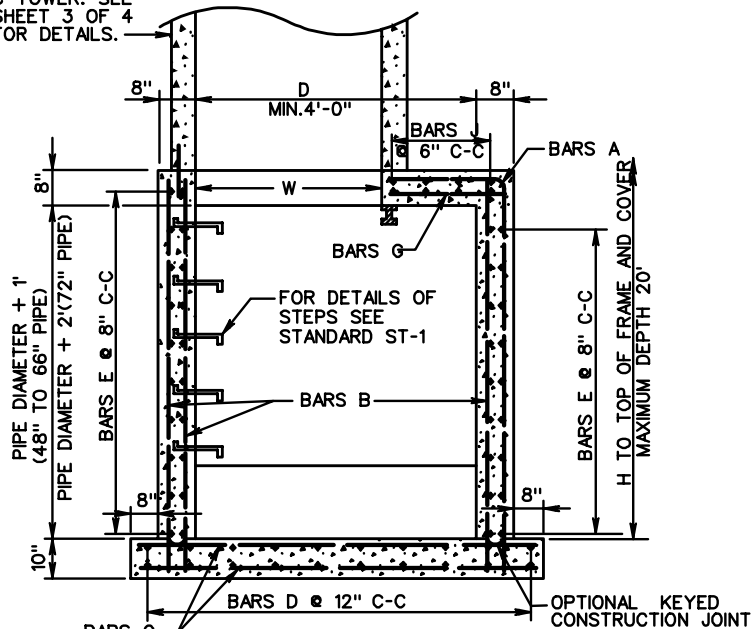

SECTION A-A

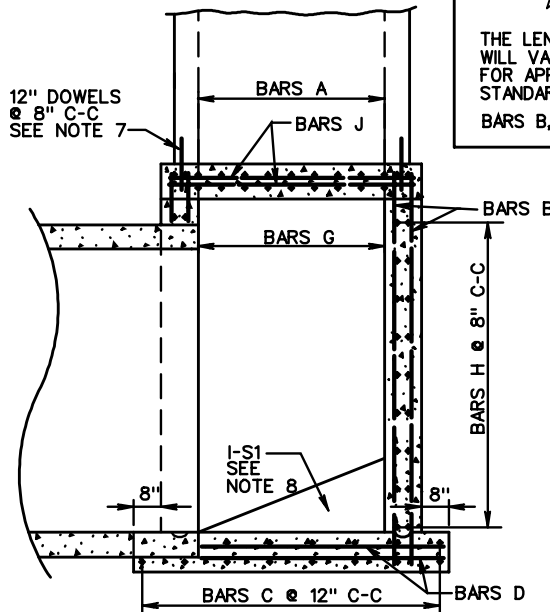

SECTION B-B

NOTES:

1. ALL REINFORCING STEEL TO BE #6 BARS WITH A MINIMUM 1/2" CONCRETE COVER.
2. ANY REINFORCING BARS IN CONFLICT WITH PIPE SHELLS ARE TO BE CUT A MINIMUM OF 1/2" FROM PIPE.
3. FOR DETAILS METHOD OF TURNING ANGLES AND APPROXIMATE QUANTITIES SEE SHEET 2 OF 4.
4. PRECAST CHAMBERS OF THE BOLT TOGETHER TYPE MAY BE SUBSTITUTED WHEN APPROVED ON AN INDIVIDUAL BASIS.
5. ALL CONCRETE TO BE CLASS A3 IF CAST IN PLACE, 4000 PSI IF PRECAST.
6. THIS ITEM MAY BE PRECAST OR CAST IN PLACE.
7. ELIMINATE DOWELS WHEN PRECAST TYPE A TOWER ARE ELECTED.
8. WHEN SPECIFIED ON PLANS INVERT IS TO BE SHAPED IN ACCORDANCE WITH STANDARD IS-1. THE MATERIALS INCIDENTAL TO THE SHAPING ARE NOT TO BE MEASURED OR PAID SEPARATELY BUT THE COST OF SAME IS TO BE INCLUDED IN THE PRICE BID PER CUBIC YARD OF JUNCTION BOX CONCRETE

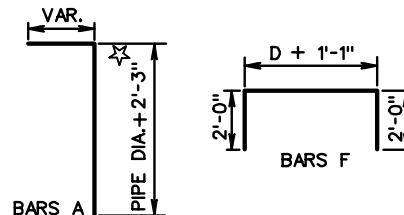

☆ INCREASE INDICATED DIMENSION BY 1' FOR USE WITH 72" PIPE.

THE LENGTH OF ALL BARS AND THE NUMBER REQUIRED WILL VARY WITH THE SIZE OF CHAMBER. FOR APPROXIMATE WEIGHT SEE SHEET 2 AND 4 OF THIS STANDARD.

BARS B, C, E, G, H, AND J ARE STRAIGHT.



ROAD AND BRIDGE STANDARDS

SHEET 1 OF 4

REVISION DATE

106.10

JUNCTION BOX CHAMBER DETAILS FOR 48" - 72" PIPE CULVERTS MAX. DEPTH (H) = 20'

VIRGINIA DEPARTMENT OF TRANSPORTATION

SPECIFICATION REFERENCE

105
233
302

LOCATION OF CHAMBER TO FIT VARIOUS FLOW LINE ANGLES

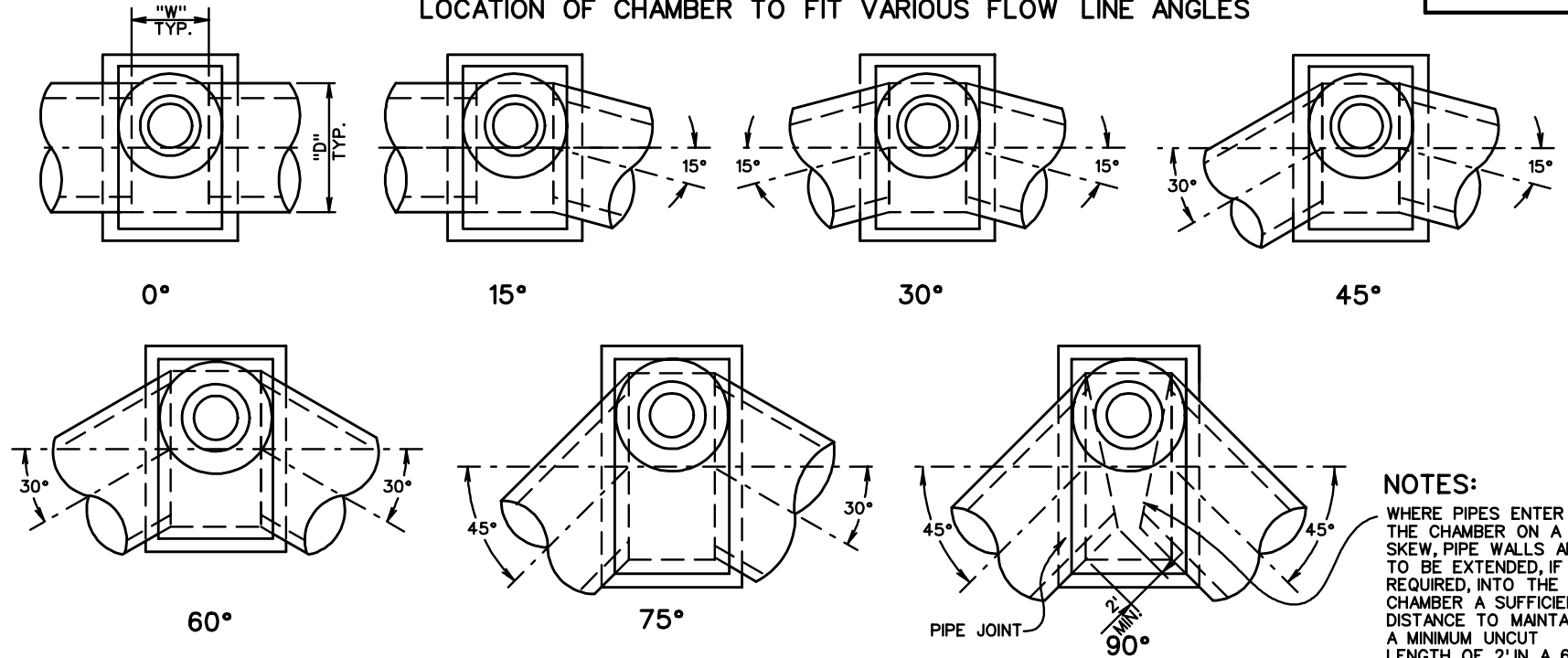

NOTES:
 WHERE PIPES ENTER THE CHAMBER ON A SKEW, PIPE WALLS ARE TO BE EXTENDED, IF REQUIRED, INTO THE CHAMBER A SUFFICIENT DISTANCE TO MAINTAIN A MINIMUM UN CUT LENGTH OF 2' IN A 6' PIPE SECTION.

QUANTITIES FOR CHAMBER *

PIPE SIZE	ANGLE OF TURN												
	0°			1° - 30°			31° - 60°			61° - 90°			
	DIM. D	CU. YDS. CONC.	LBS. REINF. STEEL	DIM. D	CU. YDS. CONC.	LBS. REINF. STEEL	DIM. D	CU. YDS. CONC.	LBS. REINF. STEEL	DIM. D	CU. YDS. CONC.	LBS. REINF. STEEL	
TYPE A "W" = 4'-0"	48"	4'-10"	4.56	1293	5'-0"	4.65	1317	5'-7"	4.99	1412	6'-10"	5.72	1602
	54"	5'-5"	5.16	1466	5'-7"	5.26	1558	6'-3"	5.10	1617	7'-8"	6.53	1798
	60"	6'-0"	5.80	1657	6'-3"	5.96	1794	6'-11"	6.38	1831	8'-6"	7.38	2064
	66"	6'-7"	6.46	2028	6'-10"	6.63	2069	7'-7"	7.12	2220	9'-4"	8.27	2510
TYPE B "W" = 3'-0"	48"	4'-10"	4.06	1149	5'-0"	4.15	1173	5'-7"	4.46	1274	6'-10"	5.12	1440
	54"	5'-5"	4.61	1308	5'-7"	4.70	1373	6'-3"	5.07	1452	7'-8"	5.85	1619
	60"	6'-0"	5.19	1487	6'-3"	5.33	1531	6'-11"	5.71	1651	8'-6"	6.63	1925
	66"	6'-7"	5.79	1815	6'-10"	5.94	1934	7'-7"	6.40	2058	9'-4"	7.45	2359
TYPE C "W" = 2'-0"	48"	4'-10"	3.53	1030	5'-0"	3.61	1052	5'-7"	3.88	1133	6'-10"	4.47	1294
	54"	5'-5"	4.02	1177	5'-7"	4.10	1236	6'-3"	4.43	1305	7'-8"	5.14	1454
	60"	6'-0"	4.54	1337	6'-3"	4.67	1381	6'-11"	5.02	1484	8'-6"	5.85	1710
	66"	6'-7"	5.09	1592	6'-10"	5.22	1674	7'-7"	5.64	1789	9'-4"	6.59	2062
	72"	7'-2"	6.19	1835	7'-5"	6.34	1885	8'-3"	6.86	2050	10'-2"	8.05	2355

* QUANTITIES SHOWN ARE FOR CHAMBER WITHOUT PIPES. PIPE DISPLACEMENT OF CONCRETE AND STEEL MUST BE DEDUCTED TO OBTAIN TRUE QUANTITIES. SEE SHEET 4 OF 4.

CHAMBER AND TOWER QUANTITIES FOR CONCRETE AND REINFORCING STEEL MUST BE ADDED TO OBTAIN TOTALS.

"W"	STRUCT. STEEL
2'-0"	30 Lbs.
3'-0"	40 Lbs.
4'-0"	50 Lbs.

SPECIFICATION REFERENCE
105
233
302

JUNCTION BOX DETAILS FOR ANGULAR CONNECTIONS OF 48" - 72" PIPE CULVERTS

VIRGINIA DEPARTMENT OF TRANSPORTATION

VDOT
 ROAD AND BRIDGE STANDARDS

REVISION DATE	SHEET 2 OF 4
	106.11

DETAILS OF TOWERS

TYPE A

TO BE USED WHEN VERTICAL DISTANCE BETWEEN GRADE AND INVERT OF PIPE IS PIPE DIAMETER PLUS 5'-4" OR GREATER (SEE NOTE 3).

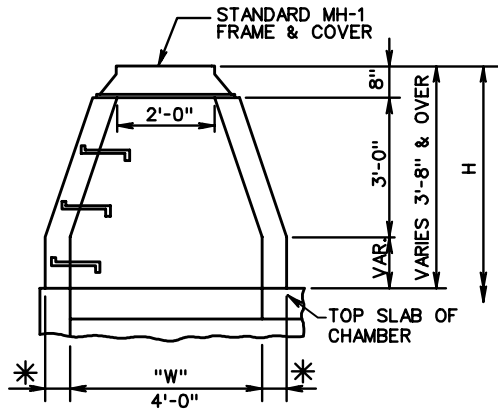

* WALL THICKNESS TO BE 6" TO A DEPTH OF 10' AND 8" OVER 10'.

SECTION A-A

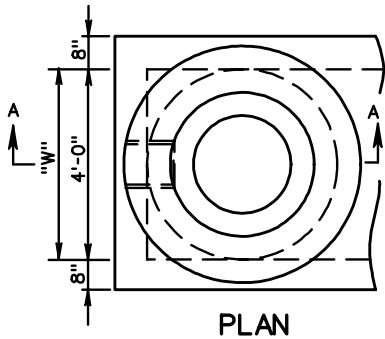

TYPE B

TO BE USED WHEN VERTICAL DISTANCE BETWEEN GRADE AND INVERT OF PIPE IS PIPE DIAMETER PLUS 3'-2" TO 5'-4" (SEE NOTE 3).

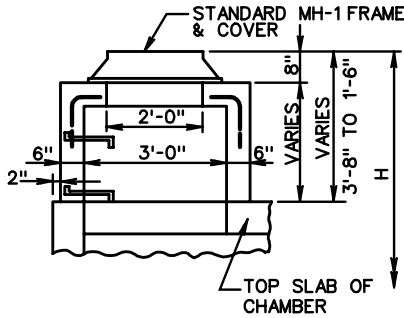

SECTION A-A

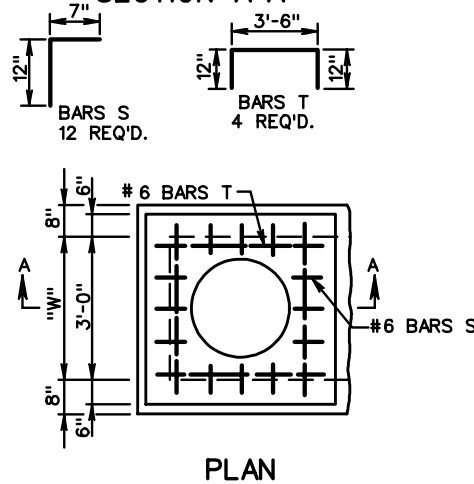

TYPE C

TO BE USED WHEN DISTANCE BETWEEN GRADE AND INVERT OF PIPE IS PIPE DIAMETER PLUS 2'-4" TO 3'-2" (SEE NOTE 3).

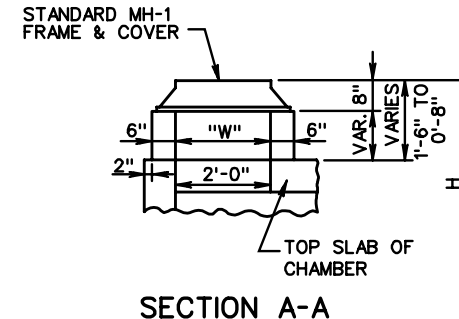

SECTION A-A

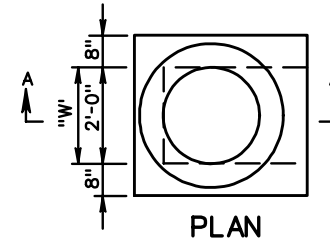

NOTES:

1. PRECAST UNITS IN ACCORDANCE WITH STANDARD MH-2 MAY BE SUBSTITUTED FOR TYPE A TOWER SHOWN. IF SUBSTITUTED, PAYMENT WILL BE MADE AT THE CONTRACT UNIT PRICE, FOR CONCRETE AND STEEL BASED ON THE THEORETICAL QUANTITIES THAT WOULD HAVE BEEN REQUIRED TO BUILD THE TYPE A TOWER.
2. SEE STANDARD SL-1 FOR APPLICABILITY OF SAFETY SLABS.
3. INCREASE INDICATED DIMENSION BY ONE FOOT FOR USE WITH 72" DIAMETER PIPE.
4. CHAMBER AND TOWER QUANTITIES FOR CONCRETE AND REINFORCING STEEL MUST BE ADDED TO OBTAIN TOTALS.

QUANTITIES FOR TOWER **

	TYPE A	TYPE B	TYPE C
CONCRETE	0.643 C.Y.	0.325 C.Y.	—
INCREMENT PER FOOT	0.262 TO 10' DEPTH 0.362 OVER 10'	0.259	0.145
REINFORCING STEEL	—	62 LBS.	—

** QUANTITIES SHOWN ARE FOR MINIMUM TOWERS OF EACH TYPE. FOR TOWERS ABOVE MINIMUM HEIGHT INCREMENTS SHOWN PER FOOT MUST BE ADDED.



ROAD AND BRIDGE STANDARDS

SHEET 3 OF 4

REVISION DATE

106.12

JUNCTION BOX TOWER DETAILS FOR 48" - 72" PIPE CULVERTS MAXIMUM DEPTH (H) = 20'

VIRGINIA DEPARTMENT OF TRANSPORTATION

SPECIFICATION REFERENCE

105
233
302

DISPLACEMENT QUANTITIES FOR PIPE OPENINGS

(TO BE USED WITH ST'D JB-I JUNCTION BOX)

PIPE SIZE	PIPE CLASS	CONCRETE				REINF. STEEL
		0°	15°	30°	45°	
		Cu. Yards	Cu. Yards	Cu. Yards	Cu. Yards	
12"	III, IV, V	.035	.036	.040	.050	17.67
12"	CM	.019	.020	.022	.027	11.06
15"	III, IV, V	.050	.052	.058	.071	24.88
15"	CM	.030	.031	.034	.042	15.93
18"	III, IV, V	.069	.072	.080	.099	33.23
18"	CM	.043	.044	.049	.061	21.68
24"	III, IV, V	.118	.122	.137	.168	53.53
24"	CM	.076	.078	.087	.108	35.83
30"	III, IV, V	.179	.186	.208	.256	78.64
30"	CM	.118	.122	.137	.168	53.53
36"	III, IV, V	.254	.263	.294	.362	108.76
36"	CM	.170	.176	.197	.242	74.76
42"	III, IV, V	.341	.353	.395	.486	143.33
42"	CM	.231	.240	.268	.330	99.53
48"	III, IV, V	.441	.457	.511	.629	182.90
48"	CM	.302	.313	.350	.431	127.85
54"	III, IV	.554	.574	.642	.789	227.29
54"	V	.580	.600	.672	.826	237.42
54"	CM	.382	.396	.443	.545	159.70
60"	III, IV	.679	.704	.787	.965	276.49
60"	V	.708	.734	.821	1.009	287.65
60"	CM	.472	.481	.551	.673	195.09
66"	III, IV	.818	.847	.948	1.166	330.50
66"	V	.849	.880	.985	1.211	342.70
66"	CM	.571	.591	.662	.814	234.02
72"	III, IV	.969	1.004	1.123	1.382	389.34
72"	V	1.003	1.040	1.163	1.431	402.58
72"	CM	.679	.704	.787	.969	276.49

SPECIFICATION REFERENCE

105
233
302

JUNCTION BOX DISPLACEMENT QUANTITIES FOR 48" - 72" PIPE CULVERTS

VIRGINIA DEPARTMENT OF TRANSPORTATION



ROAD AND BRIDGE STANDARDS

REVISION DATE

SHEET 4 OF 4

106.13

SL-1

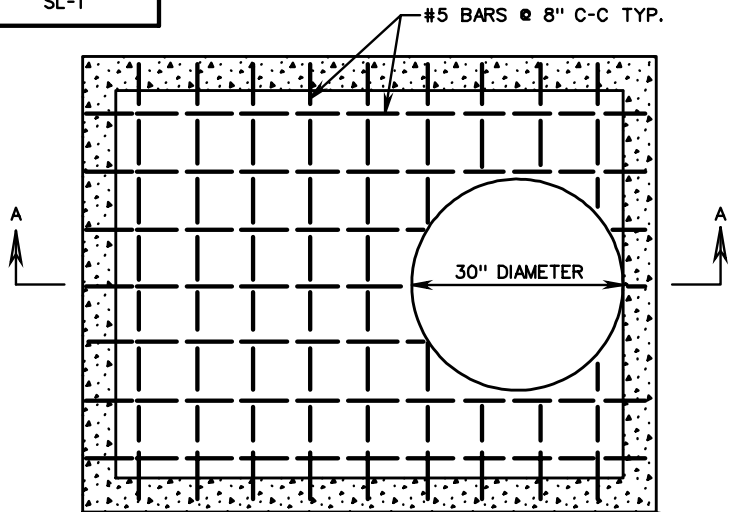

PLAN

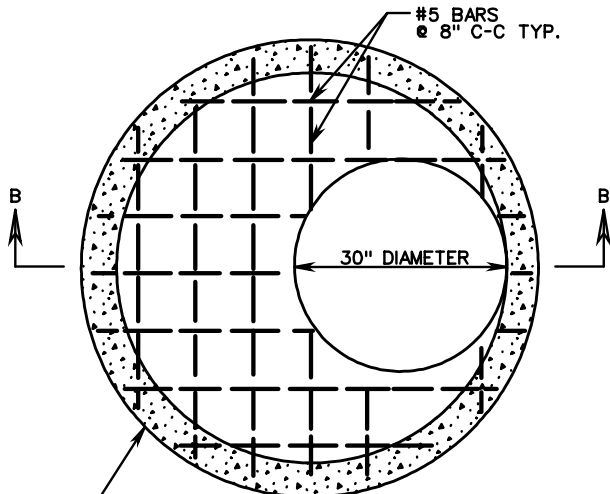

PLAN

STRUCTURE SIZE AND WALL THICKNESS VARIES

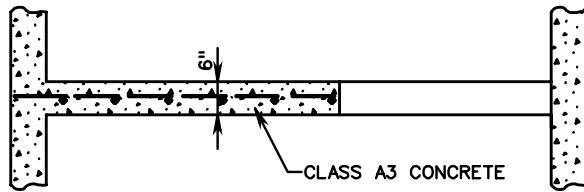

SECTION A-A

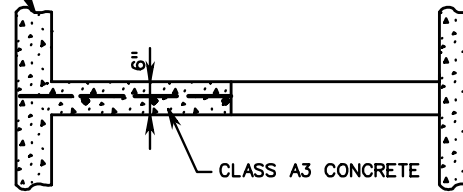

SECTION B-B

NOTES:

1. THE STANDARD SAFETY SLAB (SL-1) IS TO BE USED ONLY WHEN SPECIFIED IN THE PLANS ON THE DRAINAGE SUMMARY SHEET AND/OR THE DRAINAGE DESCRIPTION. FOR MANHOLES, JUNCTION BOXES, AND DROP INLETS WITH HEIGHTS GREATER THAN 12 FEET, THE SPACING OF ADJACENT SAFETY SLABS SHALL BE 8' TO 12' WITH NO SAFETY SLAB LOCATED WITHIN 6 FEET OF THE TOP OR BOTTOM OF THE STRUCTURE. SAFETY SLABS SHALL NOT BE LOCATED BELOW ANY INLET PIPE OF 30" DIAMETER OR GREATER.
2. THE COST OF THE SL-1 IS INCLUDED IN THE COST OF THE STRUCTURE.
3. ACCESS OPENINGS ARE TO BE STAGGERED FROM ONE SIDE OF STRUCTURE TO THE OTHER WHERE APPLICABLE. STEPS ARE TO BE STAGGERED ACCORDINGLY.
4. SAFETY SLAB MAY BE CAST-IN-PLACE OR PRECAST. CAST-IN-PLACE CONCRETE TO BE CLASS A3 (3000 PSI). PRECAST CONCRETE IS TO BE A4 (4000 PSI). REINFORCING STEEL TO BE IN ACCORDANCE WITH AASHTO M31.
5. ACCESS OPENINGS MAY BE 30" DIAMETER OR 30" SQUARE. WHEN STRUCTURE WIDTH IS LESS THAN 30" THE ACCESS OPENING SHALL BE RECTANGULAR (STRUCTURE WIDTH BY 30" LONG).

SEE CAST IN PLACE DRAWINGS FOR FURTHER DETAILS

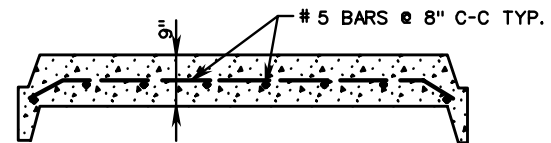

TYPICAL PRECAST UNIT



ROAD AND BRIDGE STANDARDS

SHEET 1 OF 1

REVISION DATE

106.14

TYPICAL CONCRETE SAFETY SLAB FOR DROP INLETS, MANHOLES AND JUNCTION BOXES

VIRGINIA DEPARTMENT OF TRANSPORTATION

SPECIFICATION REFERENCE

302

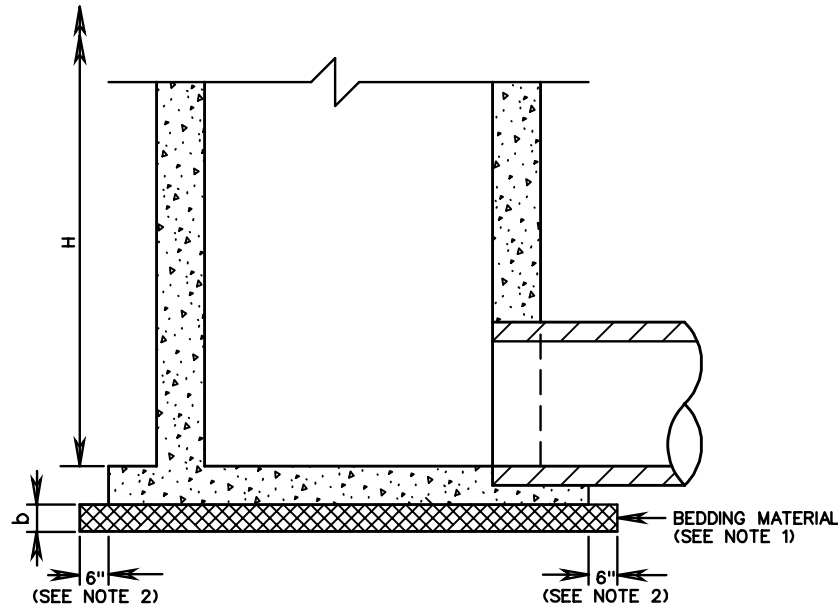

SECTIONAL ELEVATION

NOTES

1. BEDDING MATERIAL IS TO BE AGGREGATE SIZE 25 OR 26. IF FOUNDATION HAS STANDING OR RUNNING WATER PRESENT, THEN AGGREGATE NO. 57 SHALL BE USED FOR THE DEPTH SPECIFIED ON THE PLANS OR AS DIRECTED BY THE ENGINEER, CAPPED WITH 4 INCHES OF AGGREGATE NO. 25 OR 26.
2. WIDTH OF BEDDING MATERIAL SHALL EXTEND A MINIMUM OF 6" BEYOND THE BASE OF THE STRUCTURE ON ALL SIDES.
3. HEIGHT OF STRUCTURE (H) IS MEASURED FROM THE INVERT OF THE STRUCTURE TO THE TOP OF THE FRAME AND COVER OR CONCRETE DEPENDING ON STRUCTURE TYPE. SEE APPLICABLE DRAINAGE STRUCTURE STANDARD FOR DETAIL.

BEDDING THICKNESS TABLE

FOUNDATION TYPE	BEDDING THICKNESS (b)
NORMAL EARTH	4" FOR H < 10'
	6" FOR H > 10'
ROCK	1" PER FOOT OF H, MAX. 8"
SOFT & YIELDING	AS SPECIFIED ON THE PLANS OR AS DIRECTED BY THE ENGINEER

SPECIFICATION REFERENCE

302

DRAINAGE STRUCTURE BEDDING FOR DROP INLET, MANHOLE, AND JUNCTION BOX

VIRGINIA DEPARTMENT OF TRANSPORTATION

VDOT

ROAD AND BRIDGE STANDARDS

REVISION DATE

SHEET 1 OF 1

106.15

THIS PAGE INTENTIONALLY LEFT BLANK



ROAD AND BRIDGE STANDARDS

SHEET 1 OF 1

REVISION DATE

106.16

VIRGINIA DEPARTMENT OF TRANSPORTATION

SPECIFICATION
REFERENCE

GENERAL

1. METHOD "A" PIPE BEDDING SHALL BE USED FOR ALL TYPES OF PIPE CULVERTS WITHIN THE APPLICABLE HEIGHT OF COVER RANGE NOTED IN THE STANDARD PC-1 TABLES UNLESS OTHERWISE NOTED ON THE PLANS.
2. H = HEIGHT OF COVER MEASURED FROM TOP OF CULVERT TO FINISHED GRADE.
3. b = EXCAVATION DEPTH AS SHOWN ON PLANS OR TO FIRM BEARING SOIL.

CIRCULAR PIPE

1. D = OUTSIDE DIAMETER OF PIPE.
2. d = INSIDE DIAMETER OF PIPE.
3. X = WIDTH OF CLASS I BACKFILL MATERIAL BEYOND THE EXTREMITY OF THE PIPE.
 $X = 12''$ WHERE d IS LESS THAN $36''$.
 $X = 18''$ WHERE d IS $36''$ AND GREATER.
4. WHERE DIRECTED BY THE ENGINEER, BEDDING MATERIAL MAY BE ELIMINATED FOR NORMAL EARTH FOUNDATIONS UNDER ROUTINE ENTRANCE PIPE (EXCEPT PLASTIC PIPE) $30''$ AND LESS IN DIAMETER WITH HEIGHT OF COVER $15'$ OR LESS.
5. REGULAR BACKFILL MATERIAL MAY BE USED IN LIEU OF CLASS I BACKFILL MATERIAL FOR ALL FOUNDATION TYPES FOR ROUTINE ENTRANCE PIPE (EXCEPT PLASTIC PIPE) $30''$ AND LESS IN DIAMETER WITH HEIGHT OF COVER $15'$ OR LESS.
6. BEDDING MATERIAL AND CLASS I BACKFILL MATERIAL MAY BE ELIMINATED FOR SHOULDER SLOT INLET (DI-13) OUTLET PIPES INSTALLATIONS.

ELLIPTICAL PIPE

1. S_1 = OUTSIDE SPAN DIMENSION OF PIPE.
2. S_2 = INSIDE SPAN DIMENSION OF PIPE.
3. R = OUTSIDE RISE DIMENSION OF PIPE.
4. X = WIDTH OF CLASS I BACKFILL MATERIAL BEYOND THE EXTREMITY OF THE PIPE.
 $X = 12''$ WHERE S_2 IS LESS THAN $36''$.
 $X = 18''$ WHERE S_2 IS $36''$ AND GREATER
5. WHERE DIRECTED BY THE ENGINEER, BEDDING MATERIAL MAY BE ELIMINATED FOR NORMAL EARTH FOUNDATIONS UNDER ROUTINE ENTRANCE PIPE WHERE S_2 IS $38''$ OR LESS AND HEIGHT OF COVER $15'$ OR LESS.
6. REGULAR BACKFILL MATERIAL MAY BE USED IN LIEU OF CLASS I BACKFILL MATERIAL FOR ALL FOUNDATION TYPES FOR ROUTINE ENTRANCE PIPE WHERE S_2 IS $38''$ OR LESS AND HEIGHT OF COVER $15'$ OR LESS.

PIPE ARCH

1. S = SPAN DIMENSION OF PIPE.
2. R = RISE DIMENSION OF PIPE.
3. B = SEE PC-1 TABLE FOR APPLICABLE PIPE MATERIAL
4. x = WIDTH OF CLASS I BACKFILL MATERIAL BEYOND THE EXTREMITY OF THE PIPE.
 $x = 12''$ WHERE S_2 IS LESS THAN $36''$.
 $x = 18''$ WHERE S_2 IS $36''$ AND GREATER
5. WHERE DIRECTED BY THE ENGINEER, BEDDING MATERIAL MAY BE ELIMINATED FOR NORMAL EARTH FOUNDATIONS UNDER ROUTINE ENTRANCE PIPE WHERE S_2 IS $35''$ OR LESS AND HEIGHT OF COVER $15'$ OR LESS.
6. REGULAR BACKFILL MATERIAL MAY BE USED IN LIEU OF CLASS I BACKFILL MATERIAL FOR ALL FOUNDATION TYPES FOR ROUTINE ENTRANCE PIPE WHERE S IS $35''$ OR LESS AND HEIGHT OF COVER $15'$ OR LESS.

SPECIFICATION
REFERENCE302
303**INSTALLATION OF PIPE CULVERTS & STORM SEWERS
GENERAL NOTES**

VIRGINIA DEPARTMENT OF TRANSPORTATION

VDOT

ROAD AND BRIDGE STANDARDS

REVISION DATE

SHEET 1 OF 1

107.00

NO PROJECTION OF PIPE ABOVE GROUND LINE

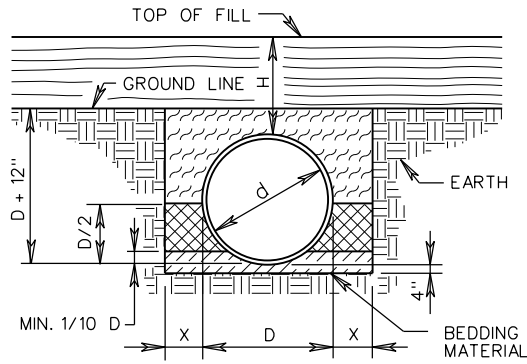

NORMAL EARTH FOUNDATION

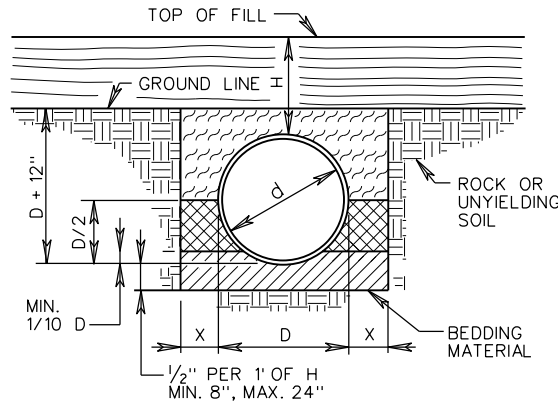

ROCK FOUNDATION

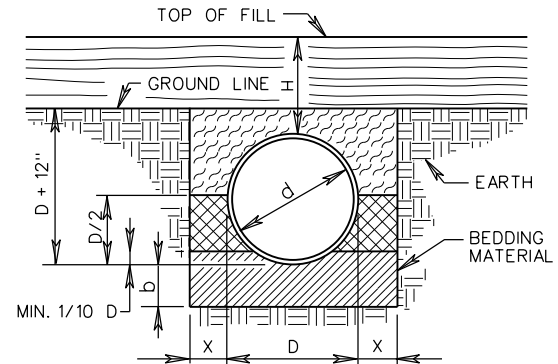

FOUNDATION SOFT, YIELDING, OR OTHERWISE UNSUITABLE MATERIAL

PIPE PROJECTION ABOVE GROUND LINE

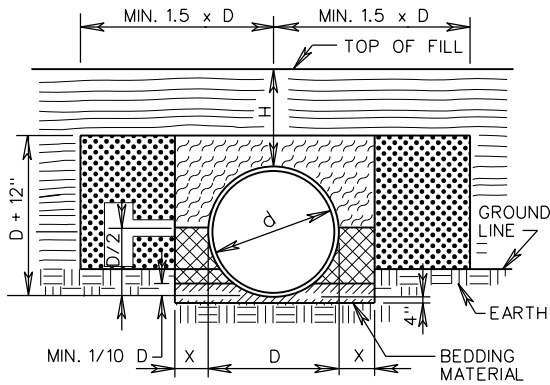

NORMAL EARTH FOUNDATION

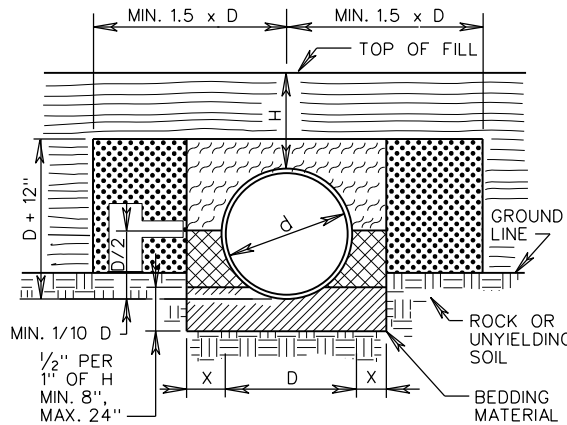

ROCK FOUNDATION

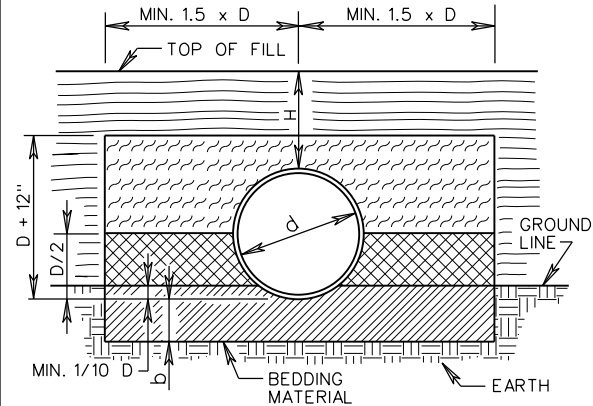

FOUNDATION SOFT, YIELDING, OR OTHERWISE UNSUITABLE MATERIAL

 BEDDING MATERIAL IN ACCORDANCE WITH SECTION 302 OF THE ROAD AND BRIDGE SPECIFICATIONS.

 CLASS I BACKFILL MATERIAL IN ACCORDANCE WITH SECTION 302 OF THE ROAD AND BRIDGE SPECIFICATIONS.

 FOR PLASTIC PIPE CLASS I BACKFILL MATERIAL IN ACCORDANCE WITH SECTION 302 OF THE ROAD AND BRIDGE SPECIFICATIONS.

 FOR ALL OTHER PIPE REGULAR BACKFILL MATERIAL IN ACCORDANCE WITH SECTION 302 OF THE ROAD AND BRIDGE SPECIFICATIONS.

 EMBANKMENT

 REGULAR BACKFILL MATERIAL IN ACCORDANCE WITH SECTION 302 OF THE ROAD AND BRIDGE SPECIFICATIONS.

NOTES:

FOR GENERAL NOTES ON PIPE BEDDING, SEE INSTALLATION OF PIPE CULVERTS AND STORM SEWERS GENERAL NOTES ON SHEET 107.00.

CRUSHED GLASS CONFORMING TO THE SIZE REQUIREMENTS FOR CRUSHER RUN AGGREGATE SIZE 25 AND 26 MAY BE USED IN PLACE OF CLASS I BACKFILL.



ROAD AND BRIDGE STANDARDS

SHEET 1 OF 4

REVISION DATE

107.01

07/12

INSTALL. OF PIPE CULVERTS AND STORM SEWERS
CIRC. PIPE BEDDING AND BACKFILL - METHOD "A"

VIRGINIA DEPARTMENT OF TRANSPORTATION

SPECIFICATION REFERENCE

302
303



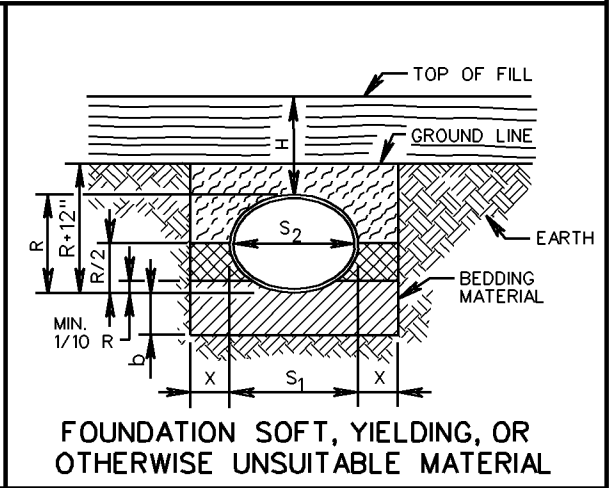
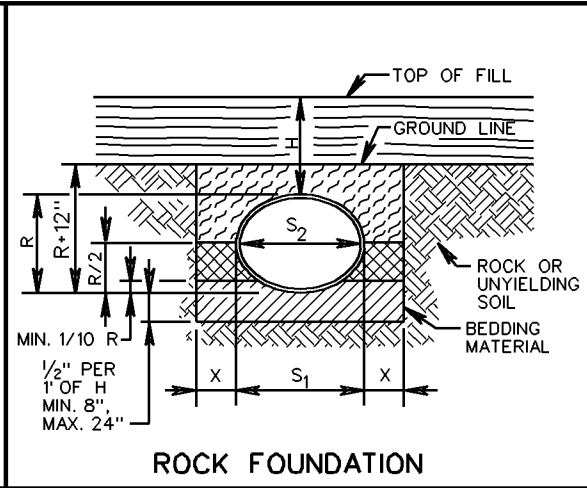
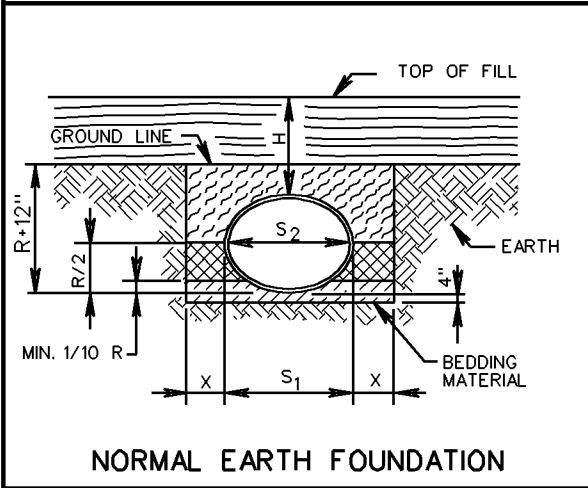

NO PROJECTION OF PIPE ABOVE GROUND LINE

PB-1

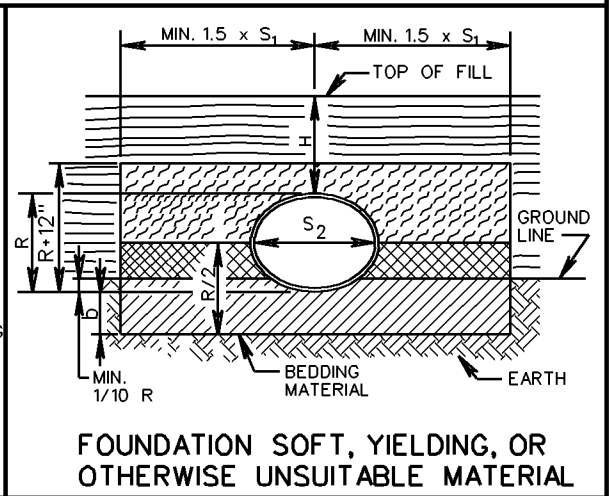
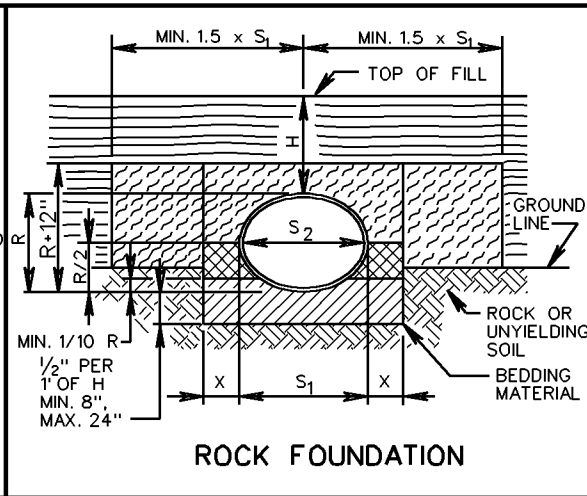
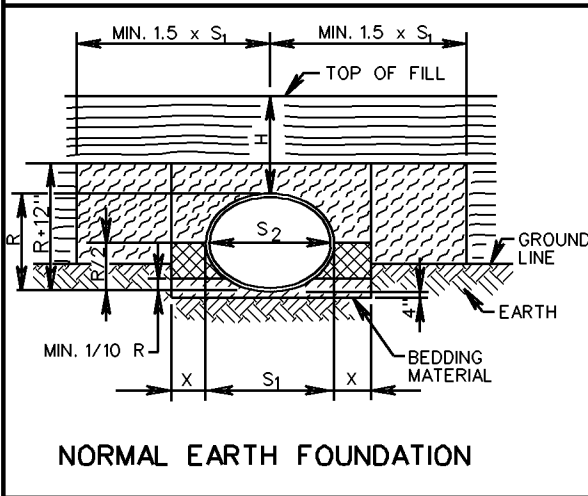

PIPE PROJECTION ABOVE GROUND LINE



-  BEDDING MATERIAL IN ACCORDANCE WITH SECTION 302 OF THE ROAD AND BRIDGE SPECIFICATIONS.
-  CLASS I BACKFILL MATERIAL IN ACCORDANCE WITH SECTION 302 OF THE ROAD AND BRIDGE SPECIFICATIONS.
-  REGULAR BACKFILL MATERIAL IN ACCORDANCE WITH SECTION 302 OF THE ROAD AND BRIDGE SPECIFICATIONS.
-  EMBANKMENT

NOTES:

FOR GENERAL NOTES ON PIPE BEDDING, SEE INSTALLATION OF PIPE CULVERTS AND STORM SEWERS GENERAL NOTES ON SHEET 107.00.
 CRUSHED GLASS CONFORMING TO THE SIZE REQUIREMENTS FOR CRUSHER RUN AGGREGATE SIZE 25 AND 26 MAY BE USED IN PLACE OF CLASS I BACKFILL.

SPECIFICATION REFERENCE
302 303

**INSTALL. OF PIPE CULVERTS AND STORM SEWERS
 ELLIP. PIPE BEDDING AND BACKFILL - METHOD "A"**

VIRGINIA DEPARTMENT OF TRANSPORTATION



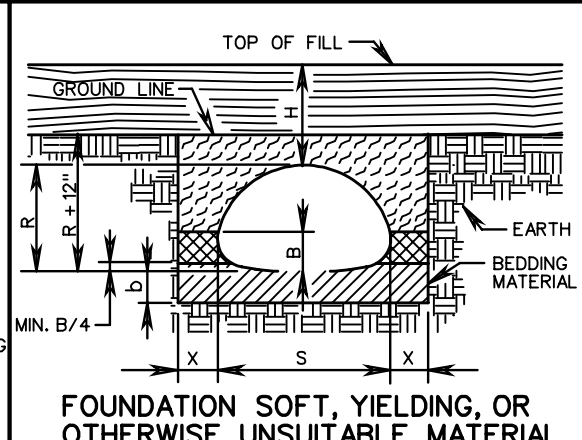
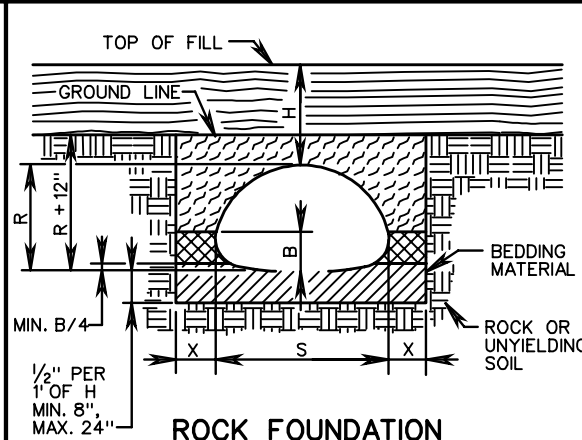
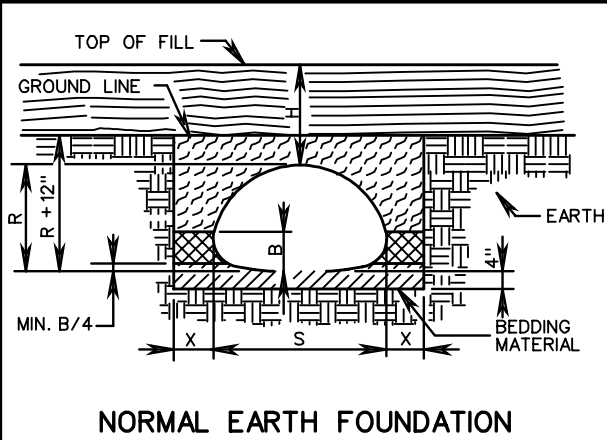

VDOT	
ROAD AND BRIDGE STANDARDS	
REVISION DATE	SHEET 2 OF 4
10/09	107.02

NO PROJECTION OF PIPE ARCH ABOVE GROUND LINE

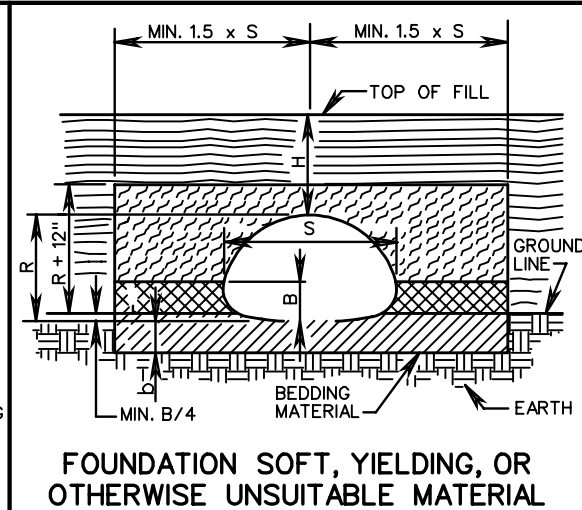
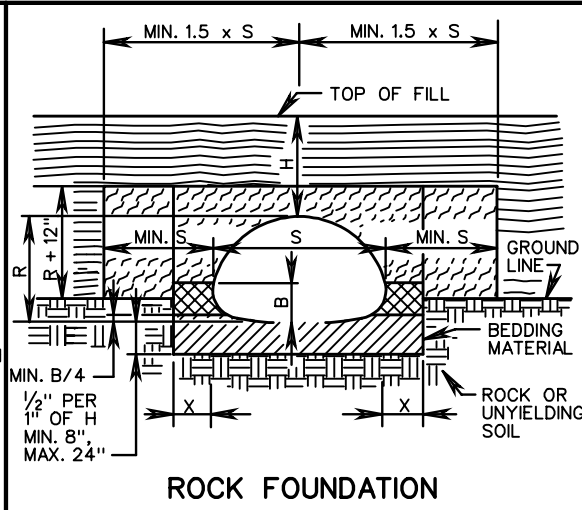
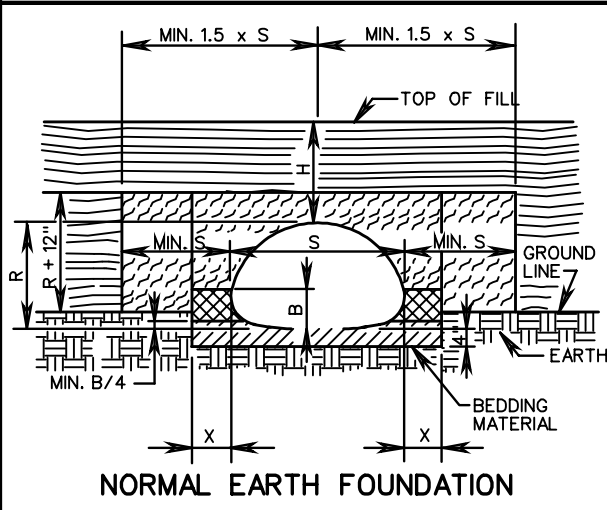

PIPE ARCH PROJECTION ABOVE GROUND LINE



-  BEDDING MATERIAL IN ACCORDANCE WITH SECTION 302 OF THE ROAD AND BRIDGE SPECIFICATIONS.
-  CLASS I BACKFILL MATERIAL IN ACCORDANCE WITH SECTION 302 OF THE ROAD AND BRIDGE SPECIFICATIONS.
-  REGULAR BACKFILL MATERIAL IN ACCORDANCE WITH SECTION 302 OF THE ROAD AND BRIDGE SPECIFICATIONS.
-  EMBANKMENT

NOTE:

FOR GENERAL NOTES ON PIPE BEDDING, SEE INSTALLATION OF PIPE CULVERTS AND STORM SEWERS GENERAL NOTES ON SHEET 107.00.

CRUSHED GLASS CONFORMING TO THE SIZE REQUIREMENTS FOR CRUSHER RUN AGGREGATE SIZE 25 AND 26 MAY BE USED IN PLACE OF CLASS I BACKFILL.



ROAD AND BRIDGE STANDARDS

SHEET 3 OF 4

REVISION DATE

107.03

INSTALLATION OF PIPE CULVERTS AND STORM SEWERS PIPE ARCH BEDDING AND BACKFILL

VIRGINIA DEPARTMENT OF TRANSPORTATION

SPECIFICATION REFERENCE

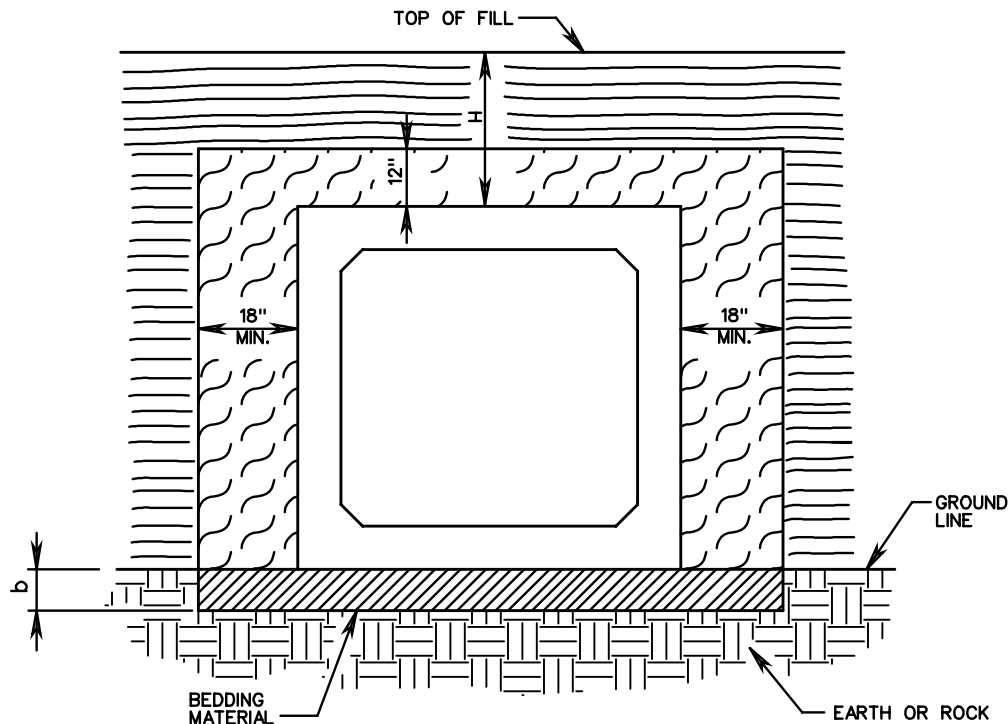

302
303



H - HEIGHT OF COVER MEASURED FROM TOP OF CULVERT TO FINISHED GRADE.

FOR NORMAL EARTH FOUNDATION:
FOR PRECAST AND CAST IN PLACE BOX CULVERT b - 6"

FOR ROCK FOUNDATION:
FOR PRECAST BOX CULVERT b = 1/4" PER 12" OF
H - 8" MIN., 24" MAX.
FOR CAST IN PLACE BOX CULVERT b-DEPTH AS SHOWN
ON PLANS OR WHERE NO BEDDING IS SPECIFIED BOTTOM
SLAB TO BE KEYED INTO EXISTING ROCK FOUNDATION.
FOR SOFT, YIELDING OR OTHERWISE UNSUITABLE FOUNDATION:
FOR PRECAST AND CAST IN PLACE BOX CULVERT
b - DEPTH AS SHOWN ON PLANS OR TO FIRM BEARING SOIL.

-  BEDDING MATERIAL IN ACCORDANCE WITH SECTION 302 OF THE ROAD AND BRIDGE SPECIFICATIONS.
-  REGULAR BACKFILL MATERIAL IN ACCORDANCE WITH SECTION 302 OF THE ROAD AND BRIDGE SPECIFICATIONS.
-  EMBANKMENT

SPECIFICATION
REFERENCE

302
303

INSTALLATION OF BOX CULVERT BEDDING AND BACKFILL - METHOD "A"

VIRGINIA DEPARTMENT OF TRANSPORTATION

VDOT

ROAD AND BRIDGE STANDARDS

REVISION DATE

SHEET 4 OF 4

107.04

DIAMETER INCHES	AREA SQ. FT.	MAXIMUM HEIGHT OF COVER IN FEET				DIAMETER INCHES
		NONREINFORCED CONCRETE (STRENGTH) (SEE NOTE 4)	REINFORCED CONCRETE CLASS			
			III	IV	V	
12	0.8	14' (1800)	14'	19'	29'	12
15	1.2	14' (2125)	14'	19'	29'	15
18	1.8	14' (2400)	14'	20'	29'	18
21	2.4	13' (2700)	14'	20'	29'	21
24	3.1	13' (3000)	14'	20'	29'	24
27	4.0		14'	20'	29'	27
30	4.9		14'	20'	29'	30
33	5.9		14'	20'	29'	33
36	7.1		14'	20'	30'	36
42	9.6		14'	21'	30'	42
48	12.6		14'	21'	30'	48
54	15.9		14'	21'	30'	54
60	19.6		14'	21'	30'	60
66	23.8		14'	21'	30'	66
72	28.3		14'	21'	30'	72
78	33.2		14'	21'	30'	78
84	38.5		14'	21'	30'	84
90	44.4		14'	21'	30'	90
96	50.3		14'	21'	30'	96
102	56.7		14'	21'	30'	102
108	63.6		14'	21'	30'	108

NOTES:

- COVER HEIGHTS INDICATED IN TABLES ARE FOR FINISHED CONSTRUCTION. THE COVER HEIGHTS WERE RETAINED TO MATCH FORMER COVER HEIGHTS BASED ON ALLOWABLE STRESS DESIGN. COVER HEIGHTS WERE NOT RE-CALCULATED USING LRFD.
- TO PROTECT PIPE DURING CONSTRUCTION, MINIMUM HEIGHTS OF COVER PRIOR TO ALLOWING CONSTRUCTION TRAFFIC TO CROSS INSTALLATION ARE TO BE $\frac{1}{2}$ DIAMETER OR 3'0", WHICHEVER IS GREATER. THE COVER SHALL EXTEND THE FULL LENGTH OF THE PIPE. THE APPROACH FILL RAMP IS TO EXTEND A MINIMUM OF 10(DIAMETER + 36") ON EACH SIDE OF THE PIPE, OR TO THE INTERSECTION WITH A CUT.
- STANDARD MINIMUM FINISHED HEIGHT OF COVER FOR ALL PIPES, EXCEPT THOSE UNDER ENTRANCES, SHALL BE 2.0' OR $\frac{1}{2}$ DIAMETER, WHICHEVER IS GREATER. IN CASES IN WHICH THESE COVER HEIGHTS CANNOT BE ACHIEVED, AN ABSOLUTE MINIMUM FINISHED COVER HEIGHT OF 1.0' WILL BE ALLOWED ONLY IF ALL POSSIBLE MEANS TO OBTAIN THE STANDARD VALUE HAVE BEEN EXHAUSTED. THE MINIMUM FINISHED HEIGHT OF COVER FOR PIPES UNDER ENTRANCES IS 9".
- CRUSHING STRENGTH (POUNDS PER LINEAR FOOT ULTIMATE STRENGTH) PER ASTM C76:
2000 LBS FOR CLASS III PIPE
3000 LBS FOR CLASS IV PIPE
3750 LBS FOR CLASS V PIPE
- FOR HEIGHT OF COVER GREATER THAN THAT SHOWN FOR CLASS V, A SPECIAL DESIGN CONCRETE PIPE IS REQUIRED.
- NONREINFORCED PIPE TO BE USED ONLY UNDER ENTRANCES AND LOWER FUNCTIONAL CLASSIFICATION (LFC) ROADWAYS (SEE SHEET 17 OF 18).
- SEE STANDARD PB-1 FOR PIPE BEDDING AND BACKFILL REQUIREMENTS.
- PIPE WITH LESS THAN THE STANDARD MINIMUM COVER IS TO BE MINIMUM CLASS III REINFORCED.



ROAD AND BRIDGE STANDARDS

SHEET 1 OF 18

REVISION DATE

107.05

11/15

A COPY OF THE ORIGINAL SEALED AND SIGNED DRAWING IS ON FILE IN THE CENTRAL OFFICE.

CONCRETE PIPE HEIGHT OF COVER TABLE FOR HL-93 LIVE LOAD

VIRGINIA DEPARTMENT OF TRANSPORTATION

SPECIFICATION
REFERENCE302
232

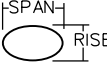
HORIZONTAL INSTALLATION 			
EQUIVALENT ROUND SIZE INCHES	SPAN X RISE INCHES	MAX. HEIGHT OF COVER IN FEET	
		CLASS	
		HE - III	HE - IV
18	23 x 14	13'	21'
24	30 x 19	13'	21'
27	34 x 22	13'	21'
30	38 x 24	13'	21'
33	42 x 27	13'	21'
36	45 x 29	13'	21'
39	49 x 32	13'	21'
42	53 x 34	13'	21'
48	60 x 38	13'	21'
54	68 x 43	13'	21'
60	76 x 48	13'	21'
66	83 x 53	13'	21'
72	91 x 58	13'	21'
78	98 x 63	13'	21'
84	106 x 68	13'	21'

VERTICAL INSTALLATION 			
SPAN X RISE INCHES	MAX. HEIGHT OF COVER IN FEET		
	CLASS		
	VE - III	VE - IV	VE - V
29 x 45	13	21	29
32 x 49	13	21	29
34 x 53	13	21	29
38 x 60	13	21	29
43 x 68	13	21	29
48 x 76	13	21	29
53 x 83	13	21	29
58 x 91	13	21	29
63 x 98	13	21	29
68 x 106	13	21	29

NOTES:

- COVER HEIGHTS INDICATED IN TABLES ARE FOR FINISHED CONSTRUCTION. THE COVER HEIGHTS WERE RETAINED TO MATCH FORMER COVER HEIGHTS BASED ON ALLOWABLE STRESS DESIGN. COVER HEIGHTS WERE NOT RE-CALCULATED USING LRFD.
- TO PROTECT PIPE DURING CONSTRUCTION, MINIMUM HEIGHTS OF COVER PRIOR TO ALLOWING CONSTRUCTION TRAFFIC TO CROSS INSTALLATION ARE TO BE 1/2 SPAN OR 3', WHICHEVER IS GREATER. THE COVER SHALL EXTEND THE FULL LENGTH OF THE PIPE. THE APPROACH FILL RAMP IS TO EXTEND A MINIMUM OF 10(SPAN + 36") ON EACH SIDE OF THE PIPE OR TO THE INTERSECTION WITH A CUT.
- STANDARD MINIMUM FINISHED HEIGHT OF COVER FOR ALL PIPES SHALL BE 2.0' OR 1/2 SPAN, WHICHEVER IS GREATER. IN CASES IN WHICH THESE COVER HEIGHTS CANNOT BE ACHIEVED, AN ABSOLUTE MINIMUM FINISHED COVER HEIGHT OF 1.0' WILL BE ALLOWED ONLY IF ALL POSSIBLE MEANS TO OBTAIN THE STANDARD VALUE HAVE BEEN EXHAUSTED. MINIMUM FINISHED HEIGHT OF COVER FOR PIPE UNDER ENTRANCES IS 9".
- SEE STANDARD PB-1 FOR PIPE BEDDING AND BACKFILL REQUIREMENTS.

SPECIFICATION REFERENCE	A COPY OF THE ORIGINAL SEALED AND SIGNED DRAWING IS ON FILE IN THE CENTRAL OFFICE. REINFORCED ELLIPTICAL CONCRETE PIPE HEIGHT OF COVER TABLES FOR HL-93 LIVE LOAD VIRGINIA DEPARTMENT OF TRANSPORTATION	 ROAD AND BRIDGE STANDARDS	

**CORRUGATED STEEL PIPE
2 2/3" x 1/2" CORRUGATIONS**

PIPE DIAMETER INCHES	AREA SQ. FT.	MAXIMUM HEIGHT OF COVER IN FEET					MINIMUM SHEET THICKNESS FOR ENTRANCE PIPES WITH LESS THAN 1 FT COVER INCHES (GAUGE)
		SHEET THICKNESS IN INCHES (GAUGE)					
		0.064 (16)	0.079 (14)	0.109 (12)	0.138 (10)	0.168 (8)	
12	0.79	233	291				0.064 (16)
15	1.23	186	233				0.064 (16)
18	1.77	155	194	272			0.064 (16)
21	2.40	132	166	233			0.064 (16)
24	3.14	116	145	203			0.064 (16)
27	3.98	102	128	180			0.064 (16)
30	4.91	92	115	162			0.064 (16)
33	5.94	83	105	147	190		0.064 (16)
36	7.1	76	96	135	174		0.064 (16)
42	9.6	65	81	115	149	182	0.064 (16)
48	12.6	56	71	100	130	159	0.064 (16)
54	16.0		63	89	115	141	0.079 (14)
60	19.6			79	103	126	0.109 (12)
66	23.8				93	114	0.138 (10)
72	28.3				85	105	0.138 (10)
78	33.2					96	0.168 (8)
84	38.5					89	0.168 (8)

NOTES:

- COVER HEIGHTS INDICATED IN TABLES ARE FOR FINISHED CONSTRUCTION, USING AASHTO LRFD BRIDGE DESIGN SPECIFICATIONS AND ASSUMING 25% METAL LOSS AT END OF DESIGN LIFE.
- TO PROTECT PIPE DURING CONSTRUCTION, MINIMUM HEIGHT OF COVER TO BE IN ACCORDANCE WITH TABLE A PRIOR TO ALLOWING CONSTRUCTION TRAFFIC TO CROSS INSTALLATION. THE COVER SHALL EXTEND THE FULL LENGTH OF THE PIPE. THE APPROACH FILL RAMP IS TO EXTEND A MINIMUM OF 15 DIAMETERS ON EACH SIDE OF THE PIPE OR THE INTERSECTION WITH A CUT.
- STANDARD MINIMUM FINISHED HEIGHT OF COVER FOR ALL PIPES, EXCEPT UNDER ENTRANCES, SHALL BE 2.0' OR 1/2 DIAMETER, WHICHEVER IS GREATER. IN CASES IN WHICH THESE COVER HEIGHTS CANNOT BE ACHIEVED, AN ABSOLUTE MINIMUM FINISHED COVER HEIGHT OF 1.0' OR 1/8 DIAMETER, WHICHEVER IS GREATER, WILL BE ALLOWED ONLY IF ALL POSSIBLE MEANS TO OBTAIN THE STANDARD VALUE HAVE BEEN EXHAUSTED. THE MINIMUM FINISHED HEIGHT OF COVER FOR PIPES UNDER ENTRANCES IS 9" FOR PIPE DIAMETERS LESS THAN OR EQUAL TO 24" AND 12" OR 1/8 DIAMETER, WHICHEVER IS GREATER, FOR PIPE DIAMETERS GREATER THAN 24". WHERE A POLYMER COATED PIPE WILL BE USED AND THE SURFACE OVER THE TOP OF THE PIPE WILL BE ASPHALT, CLASS I BACKFILL MATERIAL IS TO BE PLACED UP TO A MINIMUM OF 6" ABOVE THE TOP OF THE PIPE.
- SEE STANDARD PB-1 FOR PIPE BEDDING AND BACKFILL REQUIREMENTS.

TABLE A

PIPE DIAMETER	MINIMUM COVER HEIGHT DURING CONSTRUCTION (SEE NOTE 2)
12" TO 33"	18"
36" AND ABOVE	1/2 DIAMETER

CONCRETE- LINED CORRUGATED STEEL PIPE

MAXIMUM HEIGHT OF COVER TO BE IN ACCORDANCE WITH THE TABLES BUT SHALL NOT EXCEED 30".

**CORRUGATED STEEL PIPE
3" x 1" CORRUGATIONS**

PIPE DIAMETER INCHES	AREA SQ. FT.	MAXIMUM HEIGHT OF COVER IN FEET				
		SHEET THICKNESS IN INCHES (GAUGE)				
		0.064 (16)	0.079 (14)	0.109 (12)	0.138 (10)	0.168 (8)
36	7.1	88	110	155	200	246
42	9.6	75	94	133	171	210
48	12.6	65	82	116	149	183
54	16.0	57	72	102	132	163
60	19.6	51	65	92	119	146
66	23.8	46	58	83	108	132
72	28.3	42	53	76	98	121
78	33.2	38	49	69	90	111
84	38.5	35	45	64	83	103
90	44.2	32	41	59	77	96
96	50.3		38	55	72	89
102	56.7		36	52	68	84
108	63.6			49	64	80
114	70.9			45	60	74
120	78.5			43	56	70
132	95.0				51	63
144	113.0					57

**CORRUGATED STEEL PIPE
5" x 1" CORRUGATIONS**

PIPE DIAMETER INCHES	AREA SQ. FT.	MAXIMUM HEIGHT OF COVER IN FEET				
		SHEET THICKNESS IN INCHES (GAUGE)				
		0.064 (16)	0.079 (14)	0.109 (12)	0.138 (10)	0.168 (8)
36	7.1	78	98	138	178	218
42	9.6	66	84	118	152	187
48	12.6	58	73	103	133	163
54	16.0	51	64	91	118	144
60	19.6	45	57	81	105	130
66	23.8	41	52	74	95	117
72	28.3	37	47	67	87	107
78	33.2	34	43	61	80	99
84	38.5	31	39	57	74	91
90	44.2	28	36	53	69	85
96	50.3		34	49	64	79
102	56.7		31	46	60	74
108	63.6			43	56	69
114	70.9			40	53	65
120	78.5			38	50	62
132	95.0				44	55
144	113.0					50

A COPY OF THE ORIGINAL SEALED AND SIGNED DRAWING IS ON FILE IN THE CENTRAL OFFICE.

**CORRUGATED STEEL PIPE
HEIGHT OF COVER TABLES FOR HL-93 LIVE LOAD**

VIRGINIA DEPARTMENT OF TRANSPORTATION

SPECIFICATION REFERENCE

302
232



ROAD AND BRIDGE STANDARDS

SHEET 3 OF 18

REVISION DATE

107.07

11/15

**CORRUGATED ALUMINUM ALLOY PIPE-
2 2/3" x 1/2" CORRUGATIONS**

PIPE DIAMETER INCHES	AREA SQ. FT.	MAXIMUM HEIGHT OF COVER IN FEET					MINIMUM SHEET THICKNESS FOR ENTRANCE PIPES WITH LESS THAN 1 FT. COVER (GAUGE)
		SHEET THICKNESS IN INCHES (GAUGE)					
		0.060 (16)	0.075 (14)	0.105 (12)	0.135 (10)	0.164 (8)	
12	0.8	141	176	247	318	389	16
15	1.2	112	141	197	254	311	16
18	1.8	93	117	164	212	259	16
21	2.4	80	100	140	181	221	16
24	3.1	69	87	123	158	193	16
27	4.0		77	109	140	172	14
30	4.9		69	98	126	154	14
33	5.9		63	88	114	140	14
36	7.1		57	81	105	128	14
42	9.6			69	89	109	12
48	12.6			60	78	95	12
54	15.9			53	69	84	12
60	19.6				61	75	10
66	23.8					68	8
72	28.3					62	8

CORRUGATED ALUMINUM ALLOY PIPE- 3" x 1" CORRUGATIONS

PIPE DIAMETER INCHES	AREA SQ. FT.	MAXIMUM HEIGHT OF COVER IN FEET				
		SHEET THICKNESS IN INCHES (GAUGE)				
		0.060 (16)	0.075 (14)	0.105 (12)	0.135 (10)	0.164 (8)
36	7.1	52	66	93	126	148
42	9.6	44	56	80	107	127
48	12.6	38	49	69	93	110
54	16.0	34	43	61	83	98
60	19.6	30	38	54	74	87
66	23.8	26	34	49	67	79
72	28.3	24	31	45	61	72
78	33.2		28	41	56	66
84	38.5			37	51	61
90	44.2			34	47	57
96	50.3			32	44	53
102	56.7				41	49
108	63.6				38	46
114	70.9					43
120	78.5					41

NOTES:

- COVER HEIGHTS INDICATED IN TABLES ARE FOR FINISHED CONSTRUCTION, USING AASHTO LRFD BRIDGE DESIGN SPECIFICATIONS AND ASSUMING 25% METAL LOSS AT END OF DESIGN LIFE.
- TO PROTECT PIPE DURING CONSTRUCTION, MINIMUM HEIGHT OF COVER TO BE IN ACCORDANCE WITH TABLE A PRIOR TO ALLOWING CONSTRUCTION TRAFFIC TO CROSS INSTALLATION. THE COVER SHALL EXTEND THE FULL LENGTH OF THE PIPE. THE APPROACH FILL RAMP IS TO EXTEND A MINIMUM OF 20 DIAMETERS ON EACH SIDE OF THE PIPE OR THE INTERSECTION WITH A CUT.
- STANDARD MINIMUM FINISHED HEIGHT OF COVER FOR ALL PIPES, EXCEPT THOSE UNDER ENTRANCES, SHALL BE 2.0' OR 1/2 DIAMETER, WHICHEVER IS GREATER. IN CASES IN WHICH THESE COVER HEIGHTS CANNOT BE ACHIEVED, AN ABSOLUTE MINIMUM FINISHED COVER HEIGHT OF 1.0' OR 1/8 DIAMETER, WHICHEVER IS GREATER, WILL BE ALLOWED ONLY IF ALL POSSIBLE MEANS TO OBTAIN THE STANDARD VALUE HAVE BEEN EXHAUSTED. THE MINIMUM FINISHED HEIGHT OF COVER FOR PIPES UNDER ENTRANCES IS 9" FOR PIPE DIAMETERS EQUAL TO OR LESS THAN 18" AND 12" OR 1/8 DIAMETER, WHICHEVER IS GREATER, FOR PIPE DIAMETERS GREATER THAN 18".
- SEE STANDARD PB-1 FOR PIPE BEDDING AND BACKFILL REQUIREMENTS.

TABLE A

PIPE DIAMETER	MINIMUM COVER HEIGHT DURING CONSTRUCTION (SEE NOTE 2)
12" TO 27"	18"
30" AND OVER	EQUAL TO DIAMETER

SPECIFICATION REFERENCE

232
302

A COPY OF THE ORIGINAL SEALED AND SIGNED DRAWING IS ON FILE IN THE CENTRAL OFFICE.

**CORRUGATED ALUMINUM ALLOY PIPE
HEIGHT OF COVER TABLE FOR HL-93 LIVE LOAD**

VIRGINIA DEPARTMENT OF TRANSPORTATION



ROAD AND BRIDGE STANDARDS

REVISION DATE

11/15

SHEET 4 OF 18

107.08

MINIMUM SHEET THICKNESS AND DESIGN DATA

PIPE ARCH DIMENSION					MINIMUM SHEET THICKNESS REQUIRED INCHES (GAUGE)	MAXIMUM COVER HEIGHT IN FEET	
NOMINAL SIZE SPAN - RISE INCHES	EQUIVALENT PIPE DIAMETER INCHES	AREA SQ. FT.	MAXIMUM "B" INCHES (SEE NOTE 7)	Rc INCHES		MAXIMUM CORNER PRESSURE	
						4000 LBS./SQ. FT. (SEE NOTE 4)	6000 LBS./SQ. FT. (SEE NOTE 6)
2 2/3" x 1/2" CORRUGATIONS							
17 x 13	15	1.1	5 1/4"	3	0.064 (16)	11	17
21 x 15	18	1.6	6"	3	0.064 (16)	9	14
24 x 18	21	2.2	7 1/4"	3	0.064 (16)	8	12
28 x 20	24	2.8	8"	3	0.064 (16)	7	10
35 x 24	30	4.4	9 1/2"	3	0.064 (16)	5	8
42 x 29 ☉	36	6.4	10 1/2"	3 1/2	0.064 (16)	5	8
49 x 33 ☉	42	8.7	11 1/2"	4	0.079 (14)	5	8
57 x 38 ☉	48	11.4	13 1/2"	5	0.109 (12)	5	8
64 x 43 ☉	54	14.3	15"	6	0.109 (12)	6	9
71 x 47 ☉	60	17.6	16 1/2"	7	0.138 (10)	6	9
77 x 52 ☉	66	21.3	18"	8	0.168 (8)	6	10
83 x 57 ☉	72	25.3	20"	9	0.168 (8)	7	10
3" x 1" AND 5" x 1" CORRUGATIONS							
40 x 31 ☉	36	6.4	9 3/4"	5	0.109 (12)	8	12
46 x 36 ☉	42	8.7	11 1/2"	6	0.109 (12)	8	12
53 x 41 ☉	48	11.4	13"	7	0.109 (12)	8	13
60 x 46 ☉	54	14.3	14 3/4"	8	0.109 (12)	8	13
66 x 51 ☉	60	17.6	16 1/2"	9	0.109 (12)	9	13
73 x 55 ☉	66	22.0	21 1/2"	12	0.109 (12)	11	16
81 x 59 ☉	72	26.0	23"	14	0.109 (12)	11	17
87 x 63	78	31.0	24 1/2"	14	0.109 (12)	10	16
95 x 67	84	35.0	26 1/2"	16	0.109 (12)	11	16
103 x 71	90	40.0	27"	16	0.109 (12)	10	15
112 x 75	96	46.0	29"	18	0.109 (12)	10	16
117 x 79	102	52.0	30 3/4"	18	0.109 (12)	10	15
128 x 83	108	58.0	29 1/2"	18	0.138 (10)	9	14
137 x 87	114	64.0	30 3/4"	18	0.138 (10)	8	13
142 x 91	120	71.0	32 1/2"	18	0.168 (8)	8	12

☉ INDICATES PIPE ARCHES FOR WHICH DIMENSIONS FOR EITHER CORRUGATION MAY BE USED WITHIN HEIGHT OF COVER LIMITATIONS.

NOTES:

- COVER HEIGHTS INDICATED IN TABLES ARE FOR FINISHED CONSTRUCTION WHICH MATCH FORMER VDOT ALLOWABLE STRESS DESIGN TABLES. COVER HEIGHTS WERE NOT RE-CALCULATED USING LRFD
- TO PROTECT PIPE DURING CONSTRUCTION, MINIMUM HEIGHT OF COVER TO BE IN ACCORDANCE WITH TABLE A PRIOR TO ALLOWING CONSTRUCTION TRAFFIC TO CROSS INSTALLATION. THE COVER SHALL EXTEND THE FULL LENGTH OF THE PIPE ARCH. THE APPROACH FILL RAMP IS TO EXTEND A MINIMUM OF 10'(HEIGHT + 1/2 SPAN) ON EACH SIDE OF THE PIPE, OR TO THE INTERSECTION WITH A CUT.
- STANDARD MINIMUM FINISHED HEIGHT OF COVER FOR ALL PIPES SHALL BE 2'0" OR 1/2 SPAN, WHICHEVER IS GREATER. IN CASES IN WHICH THESE COVER HEIGHTS CANNOT BE ACHIEVED, AN ABSOLUTE MINIMUM FINISHED COVER HEIGHT OF 1.0' OR 1/8 SPAN, WHICHEVER IS GREATER, WILL BE ALLOWED ONLY IF ALL POSSIBLE MEANS TO OBTAIN THE STANDARD VALUE HAVE BEEN EXHAUSTED. WHERE POLYMER COATED PIPE WILL BE USED AND THE SURFACE OVER THE TOP OF THE PIPE WILL BE ASPHALT, CLASS I BACKFILL MATERIAL IS TO BE PLACED UP TO A MINIMUM OF 6" ABOVE THE TOP OF THE PIPE.
- SEE STANDARD PB-1 FOR PIPE BEDDING AND BACKFILL REQUIREMENTS.
- THE MAXIMUM HEIGHT OF COVER SHOWN IN THE TABLES IS BASED ON A SOIL MODULUS OF 700 PSI. ALL OTHER DESIGN CRITERIA ARE IN ACCORDANCE WITH THE AASHTO SPECIFICATIONS AND VDOT MODIFICATIONS FOR SOIL CORRUGATED METAL STRUCTURE INTERACTION SYSTEMS.
- WHEN DESIGN HEIGHT OF COVER REQUIRES THE USE OF THIS CATEGORY OF PIPE, FOUNDATION AND BACKFILL MUST BE APPROVED BY THE ENGINEER.
- SPAN OF PIPE ARCHES IS MEASURED "B" INCHES ABOVE THE INVERT. SEE DIAGRAM BELOW FOR ILLUSTRATION OF "B" DIMENSION.

PIPE ARCH SPAN	MINIMUM COVER HEIGHT DURING CONSTRUCTION (SEE NOTE 2)
17" TO 35"	18"
42" AND ABOVE	1/2 SPAN

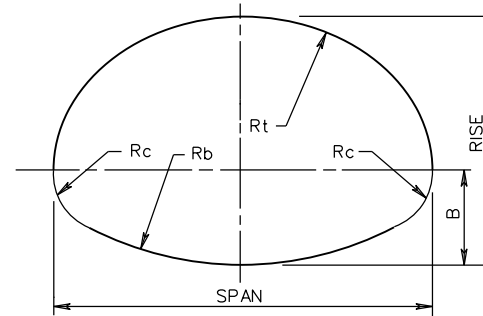

MINIMUM SHEET THICKNESS AND DESIGN DATA

PIPE ARCH DIMENSION				MINIMUM SHEET THICKNESS REQUIRED INCHES (GAUGE)	MAXIMUM COVER HEIGHT IN FEET	
NOMINAL SIZE SPAN-RISE INCHES	EQUIVALENT PIPE DIAMETER INCHES	AREA SQ. FT.	Rc INCHES		MAXIMUM CORNER PRESSURE	
					4000 LBS./SQ. FT. (SEE NOTE 4)	6000 LBS./SQ. FT. (SEE NOTE 6)
2 2/3" x 1/2" CORRUGATIONS						
17 x 13	15	1.1	3"	0.060 (16)	11	17
21 x 15	18	1.6	3"	0.060 (16)	9	14
24 x 18	21	2.2	3"	0.060 (16)	8	12
28 x 20	24	2.8	3"	0.075 (14)	7	10
35 x 24	30	4.4	3"	0.075 (14)	5	8
42 x 29 ⊗	36	6.4	3 1/2"	0.105 (12)	5	8
49 x 33 ⊗	42	8.7	4"	0.105 (12)	5	8
57 x 38 ⊗	48	11.4	5"	0.135 (10)	5	8
64 x 43 ⊗	54	14.3	6"	0.135 (10)	6	9
71 x 47 ⊗	60	17.6	7"	0.164 (8)	6	9
3" x 1" CORRUGATIONS						
40 x 31 ⊗	36	6.4	5"	0.060 (16)	8	12
46 x 36 ⊗	42	8.7	6"	0.060 (16)	8	12
53 x 41 ⊗	48	11.4	7"	0.060 (16)	8	13
60 x 46 ⊗	54	14.3	8"	0.075 (14)	8	13
66 x 51 ⊗	60	17.6	9"	0.075 (14)	9	13
73 x 55	66	22.0	12"	0.105 (12)	11	16
81 x 59	72	26.0	14"	0.105 (12)	11	17
87 x 63	78	31.0	14"	0.135 (10)	10	16
95 x 67	84	35.0	16"	0.135 (10)	11	16
103 x 71	90	40.0	16"	0.164 (8)	10	15
112 x 75	96	46.0	18"	0.164 (8)	10	13
117 x 79	102	52.0	18"	0.164 (8)	10	11

⊗ INDICATES PIPE ARCHES FOR WHICH DIMENSIONS FOR EITHER CORRUGATION MAY BE USED WITHIN HEIGHT OF COVER LIMITATIONS.

NOTES:

- COVER HEIGHTS INDICATED IN TABLES ARE FOR FINISHED CONSTRUCTION WHICH MATCH FORMER VDOT ALLOWABLE STRESS DESIGN TABLES. COVER HEIGHTS WERE NOT RE-CALCULATED USING LRFD
- TO PROTECT PIPE DURING CONSTRUCTION, MINIMUM HEIGHT OF COVER TO BE IN ACCORDANCE WITH TABLE A PRIOR TO ALLOWING CONSTRUCTION TRAFFIC TO CROSS INSTALLATION. THE COVER SHALL EXTEND THE FULL LENGTH OF THE PIPE ARCH. THE APPROACH FILL RAMP IS TO EXTEND A MINIMUM OF 10(HHEIGHT + 1/2 SPAN) ON EACH SIDE OF THE STRUCTURE OR TO THE INTERSECTION WITH A CUT.
- STANDARD MINIMUM FINISHED HEIGHT OF COVER FOR ALL PIPES SHALL BE 2'0" OR 1/8 SPAN, WHICHEVER IS GREATER. IN CASES IN WHICH THESE COVER HEIGHTS CANNOT BE ACHIEVED, AN ABSOLUTE MINIMUM FINISHED COVER HEIGHT OF 1.0' OR 1/8 SPAN, WHICHEVER IS GREATER, WILL BE ALLOWED ONLY IF ALL POSSIBLE MEANS TO OBTAIN THE STANDARD VALUE HAVE BEEN EXHAUSTED.
- SEE STANDARD PB-1 FOR PIPE BEDDING AND BACKFILL REQUIREMENTS.
- THE MAXIMUM HEIGHT OF COVER SHOWN IN THE TABLES IS BASED ON A SOIL MODULUS OF 700 PSI. ALL OTHER DESIGN CRITERIA ARE IN ACCORDANCE WITH THE AASHTO SPECIFICATIONS AND VDOT MODIFICATIONS FOR SOIL CORRUGATED METAL STRUCTURE INTERACTION SYSTEMS.
- WHEN DESIGN HEIGHT OF COVER REQUIRES THE USE OF THIS CATEGORY OF PIPE BEDDING FOUNDATION AND BACKFILL MUST BE APPROVED BY THE ENGINEER.
- LAPPED LONGITUDINAL SEAMS SHALL BE STAGGERED SO AS TO ALTERNATE ON EACH SIDE OF THE CENTER OF ARCH TOP BY APPROXIMATELY 15 PERCENT OF THE PERIPHERY.
- A TOLERANCE OF PLUS, OR MINUS, 1" IS PERMISSIBLE FOR DIMENSIONS OF SPAN, RISE, AND CORNER RADIUS.

PIPE DIAMETER	MINIMUM COVER HEIGHT DURING CONSTRUCTION (SEE NOTE 2)
17" TO 35"	18"
42" AND ABOVE	1/2 SPAN

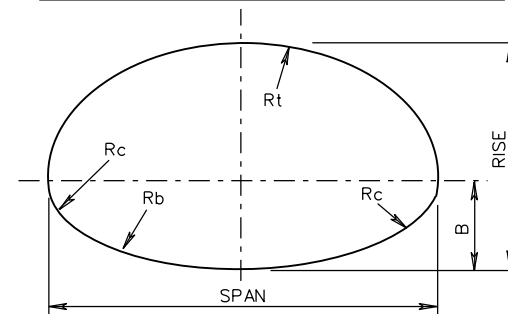

SPECIFICATION REFERENCE

232
302

A COPY OF THE ORIGINAL SEALED AND SIGNED DRAWING IS ON FILE IN THE CENTRAL OFFICE.
CORRUGATED ALUMINUM ALLOY PIPE ARCH
HEIGHT OF COVER TABLE FOR HL-93 LIVE LOAD
 VIRGINIA DEPARTMENT OF TRANSPORTATION

VDOT

ROAD AND BRIDGE STANDARDS

REVISION DATE
11/15

SHEET 6 OF 18
107.10

**STRUCTURAL PLATE STEEL PIPE-
6" x 2" CORRUGATIONS**

PIPE DIAMETER INCHES	AREA SQ. FT.	MINIMUM HEIGHT OF COVER IN FEET						
		SHEET THICKNESS IN INCHES (GAUGE)						
		0.11 (12)	0.14 (10)	0.17 (8)	0.188 (7)	0.218 (5)	0.249 (3)	0.280 (1)
60	20	91	118	145	163	191	218	246
66	24	83	107	132	148	173	198	224
72	28	75	98	120	135	158	181	205
78	33	69	90	111	124	146	167	188
84	38	64	83	103	115	135	154	175
90	44	59	77	95	107	126	144	163
96	50	55	72	89	100	117	134	152
102	57	51	67	83	94	110	126	143
108	64	48	63	78	88	104	119	134
114	71	45	60	74	83	98	112	127
120	78	43	56	70	79	92	106	120
132	95	38	50	63	71	83	96	109
144	113	34	45	57	64	76	87	99
156	133	31	41	52	58	69	80	91
168	154	28	38	47	54	63	73	83
180	177	25	34	43	49	59	68	77
192	201		31	40	45	54	63	72
204	227		29	37	42	50	58	67
216	254			34	39	47	54	62
228	284			31	36	44	51	58
240	314				34	41	48	55

NOTES:

- COVER HEIGHTS INDICATED IN TABLE ARE FOR FINISHED CONSTRUCTION, USING AASHTO LRFD BRIDGE DESIGN SPECIFICATIONS AND ASSUMING 25% METAL LOSS AT END OF DESIGN LIFE.
- TO PROTECT PIPE DURING CONSTRUCTION MINIMUM HEIGHT OF COVER PRIOR TO ALLOWING CONSTRUCTION TRAFFIC TO CROSS INSTALLATION IS TO BE 1*2 DIAMETER. THIS COVER SHALL EXTEND THE FULL LENGTH OF THE PIPE. THE APPROACH FILL RAMP IS TO EXTEND A MINIMUM OF 10(DIAMETER + 36") ON EACH SIDE OF THE PIPE OR TO THE INTERSECTION WITH A CUT.
- STANDARD MINIMUM FINISHED HEIGHT OF COVER FOR ALL PIPES SHALL BE 2.0' OR 1*2 DIAMETER, WHICHEVER IS GREATER. IN CASES IN WHICH THESE COVER HEIGHTS CANNOT BE ACHIEVED, AN ABSOLUTE MINIMUM FINISHED COVER HEIGHT OF 1.0' OR 1*8 DIAMETER WILL BE ALLOWED ONLY IF ALL POSSIBLE MEANS TO OBTAIN THE STANDARD VALUE HAVE BEEN EXHAUSTED.
- STRUCTURAL PLATE PIPE DIMENSIONS ARE TO INSIDE CREST AND ARE SUBJECT TO MANUFACTURING TOLERANCES.
- SEE STANDARD PB-1 FOR BEDDING AND BACKFILL REQUIREMENTS.



ROAD AND BRIDGE STANDARDS

A COPY OF THE ORIGINAL SEALED AND SIGNED DRAWING IS ON FILE IN THE CENTRAL OFFICE.

**STRUCTURAL PLATE STEEL PIPE
HEIGHT OF COVER TABLE FOR HL-93 LIVE LOAD**

VIRGINIA DEPARTMENT OF TRANSPORTATION

SPECIFICATION
REFERENCE

SHEET 7 OF 18

REVISION DATE

107.11

11/15

232
302

STRUCTURAL PLATE ALUMINUM ALLOY PIPE 9" x 2 1/2" CORRUGATIONS								
PIPE DIAMETER INCHES	AREA SQ. FT.	MAXIMUM HEIGHT OF COVER IN FEET						
		SHEET THICKNESS IN INCHES						
		0.10	0.125	0.15	0.175	0.20	0.225	0.25
60	20	59	74	90	105	120	136	151
66	24	53	67	81	95	109	123	137
72	28	48	61	74	87	100	112	125
78	33	44	56	68	80	92	103	115
84	38	41	52	63	74	85	96	107
90	44	38	48	58	68	79	89	99
96	50	35	44	54	64	73	83	93
102	57	32	41	50	60	69	78	88
108	64	30	39	47	56	64	73	82
114	71	28	36	44	53	61	69	77
120	78	26	34	42	49	57	65	73
132	95	23	30	37	44	51	58	65
144	113	20	27	33	40	46	53	59
156	133		24	30	36	42	48	54
168	154			27	33	38	44	49
180	177				30	35	40	45
192	201					32	37	42
204	227					29	34	39
216	254						31	36
228	284							33

NOTES:

- COVER HEIGHTS INDICATED IN TABLE ARE FOR FINISHED CONSTRUCTION, USING AASHTO LRFD BRIDGE DESIGN SPECIFICATIONS AND ASSUMING 25% METAL LOSS AT END OF DESIGN LIFE.
- TO PROTECT PIPE DURING CONSTRUCTION, MINIMUM HEIGHT OF COVER PRIOR TO ALLOWING CONSTRUCTION TRAFFIC TO CROSS INSTALLATION SHALL BE 1/2 DIAMETER. THIS COVER SHALL EXTEND THE FULL LENGTH OF THE PIPE. THE APPROACH FILL RAMP IS TO EXTEND A MINIMUM OF 10(DIAMETER + 36") ON EACH SIDE OF THE PIPE OR TO THE INTERSECTION WITH A CUT.
- STANDARD MINIMUM FINISHED HEIGHT OF COVER FOR ALL PIPES SHALL BE 2.0' OR 1/2 DIAMETER, WHICHEVER IS GREATER. IN CASES IN WHICH THESE COVER HEIGHTS CANNOT BE ACHIEVED, AND ABSOLUTE MINIMUM FINISHED COVER HEIGHT OF 1.0' OR 1/8 DIAMETER, WHICHEVER IS GREATER, WILL BE ALLOWED ONLY IF ALL POSSIBLE MEANS TO OBTAIN THE STANDARD VALUE HAVE BEEN EXHAUSTED.
- SEE STANDARD PB-1 FOR PIPE BEDDING AND BACKFILL REQUIREMENTS.
- STEEL BOLTS ONLY TO BE USED. BOLTS ARE 3/4" DIAMETER HIGH STRENGTH TO MEET CURRENT AASHTO DESIGNATION M-164 AND GALVANIZED TO MEET CURRENT ASTM DESIGNATION A-394. BOLTS ARE TO BE LOCATED IN THE VALLEY AND CREST OF EACH CORRUGATION IN DOUBLE ROWS SPACED 1 3/4" APART.

SPECIFICATION REFERENCE
232 302

A COPY OF THE ORIGINAL SEALED AND SIGNED DRAWING IS ON FILE IN THE CENTRAL OFFICE.

**STRUCTURAL PLATE ALUMINUM ALLOY PIPE
HEIGHT OF COVER TABLE FOR HL-93 LIVE LOAD**

VIRGINIA DEPARTMENT OF TRANSPORTATION

VDOT ROAD AND BRIDGE STANDARDS	
REVISION DATE	SHEET 8 OF 18
11/15	107.12

MINIMUM THICKNESS-STRUCTURAL PLATE STEEL PIPE ARCHES 6" x 2" CORRUGATIONS

PIPE ARCH DIMENSION				MINIMUM SHEET THICKNESS REQUIRED GAUGE	MAXIMUM ALLOWABLE COVER HEIGHT IN FEET	
NOMINAL SIZE		AREA SQ. FT.	Rc INCHES		MAXIMUM CORNER PRESSURE	
SPAN	RISE				4000 LBS./SQ.FT. (SEE NOTE 4)	6000 LBS./SQ.FT. (SEE NOTE 6)
6'-1"	4'-7"	22	18	12	16	24
6'-4"	4'-9"	24	18	12	15	23
6'-9"	4'-11"	26	18	12	14	22
7'-0"	5'-1"	28	18	12	14	21
7'-3"	5'-3"	31	18	12	13	20
7'-8"	5'-5"	33	18	12	12	19
7'-11"	5'-7"	35	18	12	12	18
8'-2"	5'-9"	38	18	12	12	18
8'-7"	5'-11"	40	18	12	11	17
8'-10"	6'-1"	43	18	12	11	16
9'-4"	6'-3"	46	18	12	10	16
9'-6"	6'-5"	49	18	12	10	15
9'-9"	6'-7"	52	18	12	10	15
10'-3"	6'-9"	55	18	12	9	14
10'-8"	6'-11"	58	18	12	9	14
10'-11"	7'-1"	61	18	12	9	13
11'-5"	7'-3"	64	18	12	8	13
11'-7"	7'-5"	67	18	12	8	12
11'-10"	7'-7"	71	18	12	8	12
12'-4"	7'-9"	74	18	12	8	12
12'-6"	7'-11"	78	18	12	8	12
12'-8"	8'-1"	81	18	12	7	11
12'-10"	8'-4"	85	18	12	7	11
13'-5"	8'-5"	89	18	12	7	11
13'-11"	8'-7"	93	18	12	7	10
14'-1"	8'-9"	97	18	12	7	10
14'-3"	8'-11"	101	18	12	6	10
14'-10"	9'-1"	105	18	12	6	10
15'-4"	9'-3"	109	18	12	6	9
15'-6"	9'-5"	113	18	12	6	9
15'-8"	9'-7"	118	18	12	6	9
15'-10"	9'-10"	122	18	12	6	9
16'-5"	9'-11"	126	18	12	6	9
16'-7"	10'-1"	131	18	12	6	9

NOTES:

1. COVER HEIGHTS INDICATED IN TABLES ARE FOR FINISHED CONSTRUCTION WHICH MATCH FORMER VDOT ALLOWABLE STRESS DESIGN TABLES. COVER HEIGHTS WERE NOT RE-CALCULATED USING LRFD.
2. TO PROTECT PIPE DURING CONSTRUCTION, MINIMUM HEIGHT OF COVER PRIOR TO ALLOWING CONSTRUCTION TRAFFIC TO CROSS INSTALLATION SHALL BE 1/2 SPAN. THE COVER SHALL EXTEND THE FULL LENGTH OF THE PIPE ARCH. THE APPROACH FILL RAMP IS TO EXTEND A MINIMUM OF 10(HHEIGHT + 1/2 SPAN) ON EACH SIDE OF THE STRUCTURE, OR TO THE INTERSECTION WITH A CUT.
3. STANDARD MINIMUM FINISHED HEIGHT OF COVER FOR ALL PIPES SHALL BE 2.0' OR 1/2 SPAN, WHICHEVER IS GREATER. IN CASES IN WHICH THESE COVER HEIGHTS CANNOT BE ACHIEVED, AN ABSOLUTE MINIMUM FINISHED COVER HEIGHT OF 1.0' OR 1/8 SPAN, WHICHEVER IS GREATER, WILL BE ALLOWED ONLY IF ALL POSSIBLE MEANS TO OBTAIN THE STANDARD VALUE HAVE BEEN EXHAUSTED.
4. SEE STANDARD PB-1 FOR PIPE BEDDING AND BACKFILL REQUIREMENTS.
5. THE MAXIMUM HEIGHT OF COVER SHOWN IN THE TABLES IS BASED ON A SOIL MODULUS OF 700 PSI. ALL OTHER DESIGN CRITERIA ARE IN ACCORDANCE WITH THE AASHTO SPECIFICATIONS AND VDOT MODIFICATIONS FOR SOIL CORRUGATED METAL STRUCTURE INTERACTION SYSTEMS.
6. WHEN DESIGN HEIGHT OF COVER REQUIRES THE USE OF THIS CATEGORY OF PIPE, BEDDING AND BACKFILL MUST BE APPROVED BY THE ENGINEER.
7. STRUCTURAL PLATE PIPE-ARCH DIMENSIONS ARE TO INSIDE OF CREST AND ARE SUBJECT TO MANUFACTURING TOLERANCES.

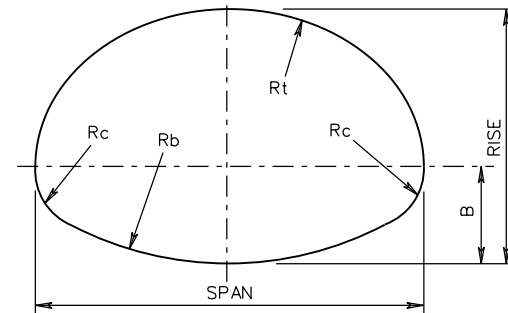

MINIMUM THICKNESS-STRUCTURAL PLATE STEEL PIPE ARCHES 6" x 2" CORRUGATIONS

PIPE ARCH DIMENSION				MINIMUM SHEET THICKNESS REQUIRED GAUGE	MAXIMUM ALLOWABLE COVER HEIGHT IN FEET	
SPAN	RISE	AREA SQ. FT.	Rc INCHES		MAXIMUM CORNER PRESSURE	
					4000 LBS./SQ. FT. (SEE NOTE 4)	6000 LBS./SQ. FT. (SEE NOTE 6)
13'-3'	9'-4"	97	31	12	12	18 ⊗
13'-6'	9'-6"	102	31	12	12	17 ⊗
14'-0"	9'-8"	105	31	12	12	17 ⊗
14'-2"	9'-10"	109	31	12	12	16 ⊗
14'-5"	10'-0"	114	31	12	11	16 ⊗
14'-11"	10'-2"	118	31	12	11	16 ⊗
15'-4"	10'-4"	123	31	12	11	15 ⊗
15'-7"	10'-6"	127	31	12	11	15 ⊗
15'-10"	10'-8"	132	31	12	10	14 ⊗
16'-3"	10'-10"	137	31	12	10	14 ⊗
16'-6"	11'-0"	142	31	12	10	14 ⊗
17'-0"	11'-2"	146	31	12	10	14 ⊗
17'-2"	11'-4"	151	31	12	10	13 ⊗
17'-5"	11'-6"	157	31	12	9	13 ⊗
17'-11"	11'-8"	161	31	12	9	13 ⊗
18'-1"	11'-10"	167	31	12	9	13 ⊗
18'-7"	12'-0"	172	31	12	9	12 ⊗
18'-9"	12'-2"	177	31	12	9	12 ⊗
19'-3"	12'-4"	182	31	10	8	13
19'-6"	12'-6"	188	31	10	8	13
19'-8"	12'-8"	194	31	10	8	13
19'-11"	12'-10"	200	31	10	8	12
20'-5"	13'-0"	205	31	10	8	12
20'-7"	13'-2"	211	31	10	8	12

⊗ MAXIMUM COVER HEIGHTS SHOWN MAY BE INCREASED BY A MAXIMUM OF 12" IF A SHEET THICKNESS GREATER THAN 12 GAUGE IS USED.

NOTES:

1. COVER HEIGHTS INDICATED IN TABLES ARE FOR FINISHED CONSTRUCTION WHICH MATCH FORMER VDOT ALLOWABLE STRESS DESIGN TABLES. COVER HEIGHTS WERE NOT RE-CALCULATED USING LRFD.
2. TO PROTECT PIPE DURING CONSTRUCTION, MINIMUM HEIGHT OF COVER PRIOR TO ALLOWING CONSTRUCTION TRAFFIC TO CROSS INSTALLATION SHALL BE 1/2 SPAN. THE COVER SHALL EXTEND THE FULL LENGTH OF THE PIPE ARCH. THE APPROACH FILL RAMP IS TO EXTEND A MINIMUM OF 10(HHEIGHT + 1/2 SPAN) ON EACH SIDE OF THE STRUCTURE OR TO THE INTERSECTION WITH A CUT.
3. STANDARD MINIMUM FINISHED HEIGHT OF COVER FOR ALL PIPES SHALL BE 1/4 SPAN. IN CASES IN WHICH THIS COVER HEIGHT CANNOT BE ACHIEVED, AN ABSOLUTE MINIMUM FINISHED COVER HEIGHT OF 1/8 SPAN WILL BE ALLOWED ONLY IF ALL POSSIBLE MEANS TO OBTAIN THE STANDARD VALUE HAVE BEEN EXHAUSTED.
4. SEE STANDARD PB-1 FOR PIPE BEDDING AND BACKFILL REQUIREMENTS.
5. STRUCTURAL PLATE PIPE-ARCH DIMENSIONS ARE TO INSIDE OF CREST AND ARE SUBJECT TO MANUFACTURING TOLERANCES.
6. WHEN DESIGN HEIGHT OF COVER REQUIRES THE USE OF THIS CATEGORY OR PIPE, BEDDING AND BACKFILL MUST BE APPROVED BY THE ENGINEER.
7. THE MAXIMUM HEIGHT OF COVER SHOWN IN THE TABLES IS BASED ON A SOIL MODULUS OF 700 PSI. ALL OTHER DESIGN CRITERIA ARE IN ACCORDANCE WITH THE AASHTO SPECIFICATIONS AND VDOT MODIFICATIONS FOR SOIL CORRUGATED METAL STRUCTURE INTERACTION SYSTEMS.

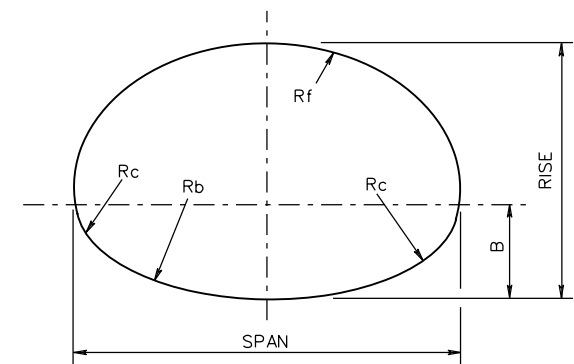

SPECIFICATION REFERENCE

232
302

A COPY OF THE ORIGINAL SEALED AND SIGNED DRAWING IS ON FILE IN THE CENTRAL OFFICE.

STRUCTURAL PLATE STEEL PIPE ARCH HEIGHT OF COVER TABLE FOR HL-93 LIVE LOAD

VIRGINIA DEPARTMENT OF TRANSPORTATION

VDOT

ROAD AND BRIDGE STANDARDS

REVISION DATE

11/15

SHEET 10 OF 5

107.14

STRUCTURAL PLATE ALUMINUM ALLOY PIPE ARCHES 9' x 2 1/2" CORRUGATIONS

SPAN	RISE	CORNER RADIUS	MAXIMUM COVER HEIGHT IN FEET								AREA SQ.FT.
			MINIMUM SHEET THICKNESS IN INCHES								
			MAXIMUM CORNER PRESSURE IN LBS./SQ. FT.								
			0.100"		0.125"		0.150"		0.175"		
4000 (SEE NOTE 4)	4000 (SEE NOTE 4)	6000 (SEE NOTE 6)	4000 (SEE NOTE 4)	6000 (SEE NOTE 6)	4000 (SEE NOTE 6)	6000 (SEE NOTE 6)	4000 (SEE NOTE 6)	6000 (SEE NOTE 6)			
6'-2"	5'-0"	31.8	25	28	36	28	42	28	42	24.7	
6'-7"	4'-11"	31.8	23	26	34	26	40	26	40	26.6	
6'-7"	5'-8"	31.8	23	26	34	26	40	26	40	29.6	
6'-11"	5'-9"	31.8	22	25	32	25	38	25	38	31.9	
7'-3"	5'-11"	31.8	21	24	31	24	36	24	36	34.3	
7'-9"	6'-0"	31.8	20	22	29	22	34	22	34	36.8	
8'-1"	6'-1"	31.8	19	21	28	21	32	21	32	39.3	
8'-5"	6'-3"	31.8	18	20	27	20	31	20	31	41.9	
8'-10"	6'-4"	31.8	17	20	25	20	30	20	30	44.5	
9'-3"	6'-5"	31.8	16	19	24	19	28	19	28	45.1	
9'-7"	6'-6"	31.8	16	18	23	18	27	18	27	49.9	
9'-11"	6'-8"	31.8	15	17	22	17	26	17	26	52.7	
10'-3"	6'-9"	31.8	15	17	22	17	25	17	25	55.5	
10'-9"	6'-10"	31.8	14	16	21	16	24	16	24	58.4	
11'-1"	7'-0"	31.8	14	15	20	15	23	15	23	61.4	
11'-5"	7'-1"	31.8	13	15	19	15	23	15	23	64.4	
11'-9"	7'-2"	31.8	13	15	19	15	22	15	22	67.5	
12'-3"	7'-3"	31.8	12	14	18	14	21	14	21	70.5	
12'-7"	7'-5"	31.8	12	14	18	14	21	14	21	73.7	
12'-11"	7'-6"	31.8	12	13	17	13	20	13	20	77.0	
13'-1"	8'-2"	31.8	11	13	17	13	20	13	20	83.0	
13'-1"	8'-4"	31.8	11	13	17	13	20	13	20	86.8	
13'-11"	8'-5"	31.8	11	12	16	12	19	12	19	90.3	
14'-0"	8'-7"	31.8	11	12	16	12	18	12	18	94.2	
13'-11"	9'-5"	31.8	11	12	16	12	19	12	19	101.5	
14'-3"	9'-7"	31.8	10	12	15	12	18	12	18	105.7	
14'-8"	9'-8"	31.8		12	14	12	17	12	18	109.9	
14'-11"	9'-10"	31.8		11	13	11	16	11	17	114.2	
15'-4"	10'-0"	31.8		11	12	11	14	11	17	118.6	
15'-7"	10'-2"	31.8		11	11	11	14	11	16	123.1	
16'-1"	10'-4"	31.8		10		10	12	10	15	127.6	
16'-4"	10'-6"	31.8				10	12	10	14	132.3	
16'-9"	10'-8"	31.8				10	11	10	13	136.9	
17'-0"	10'-10"	31.8				10		10	12	141.8	
17'-3"	11'-0"	31.8				10		10	12		
18'-0"	11'-4"	31.8						9	10		

NOTES:

1. COVER HEIGHTS INDICATED IN TABLES ARE FOR FINISHED CONSTRUCTION WHICH MATCH FORMER VDOT ALLOWABLE STRESS DESIGN TABLES. COVER HEIGHTS WERE NOT RE-CALCULATED USING LRFD.
2. TO PROTECT PIPE DURING CONSTRUCTION, MINIMUM HEIGHT OF COVER PRIOR TO ALLOWING CONSTRUCTION TRAFFIC TO CROSS INSTALLATION TO BE 1/2 SPAN. THE COVER SHALL EXTEND THE FULL LENGTH OF THE PIPE ARCH. THE APPROACH FILL RAMP IS TO EXTEND A MINIMUM OF 10(RISE + 1/2 SPAN) ON EACH SIDE OF THE PIPE, OR TO THE INTERSECTION WITH A CUT.
3. STANDARD MINIMUM FINISHED HEIGHT OF COVER FOR ALL PIPES SHALL BE 2.0' OR 1/4 SPAN, WHICHEVER IS GREATER. IN CASES IN WHICH THESE COVER HEIGHTS CANNOT BE ACHIEVED, AN ABSOLUTE MINIMUM FINISHED COVER HEIGHT OF 1.0' OR 1/8 SPAN, WHICHEVER IS GREATER, WILL BE ALLOWED ONLY IF ALL POSSIBLE MEANS TO OBTAIN THE STANDARD VALUE HAVE BEEN EXHAUSTED.
4. SEE STANDARD PB-1 FOR BEDDING AND BACKFILL REQUIREMENTS.
5. THE MAXIMUM HEIGHT OF COVER SHOWN IN THE TABLES IS BASED ON A SOIL MODULUS OF 700 PSI. ALL OTHER DESIGN CRITERIA ARE IN ACCORDANCE WITH THE AASHTO SPECIFICATIONS AND VDOT MODIFICATIONS FOR SOIL CORRUGATED METAL STRUCTURE INTERACTION SYSTEMS.
6. WHEN DESIGN HEIGHT OF COVER REQUIRES THE USE OF THIS CATEGORY OF PIPE, BEDDING AND BACKFILL MUST BE APPROVED BY THE ENGINEER.
7. BOLTS ARE 3/4" DIAMETER, HIGH STRENGTH TO MEET CURRENT A.S.T.M. DESIGNATION M-164 AND GALVANIZED TO MEET CURRENT A.S.T.M. DESIGNATION A-394. BOLTS ARE TO BE LOCATED IN THE VALLEY AND CREST OF EACH CORRUGATION IN DOUBLE ROWS SPACED 1 3/4" APART.
8. STRUCTURAL PLATE PIPE-ARCH DIMENSIONS ARE TO INSIDE CREST AND ARE SUBJECT TO MANUFACTURING TOLERANCES.

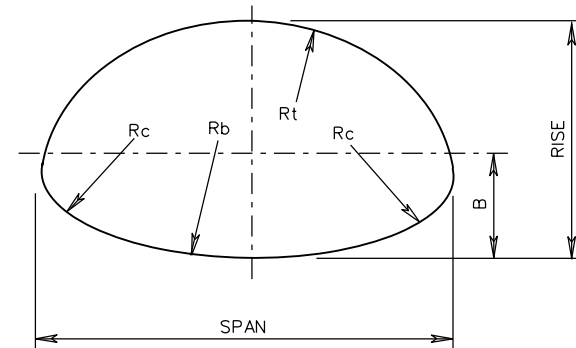

ROAD AND BRIDGE STANDARDS

SHEET 11 OF 18

REVISION DATE

107.15

11/15

A COPY OF THE ORIGINAL SEALED AND SIGNED DRAWING IS ON FILE IN THE CENTRAL OFFICE.
STRUCTURAL PLATE ALUMINUM ALLOY PIPE ARCH
HEIGHT OF COVER TABLE FOR HL-93 LIVE LOAD
 VIRGINIA DEPARTMENT OF TRANSPORTATION

SPECIFICATION REFERENCE

232
302

ALUMINUM SPIRAL RIB PIPE 3/4" WIDE x 3/4" DEEP RIBS SPACED @ 7 1/2"

PIPE DIAMETER INCHES	AREA SQ. FT.	MAXIMUM HEIGHT OF COVER IN FEET				MINIMUM SHEET THICKNESS FOR ENTRANCE PIPES WITH LESS THAN 1 FT. COVER INCHES (GAUGE)
		SHEET THICKNESS IN INCHES (GAUGE)				
		0.06 (16)	0.075 (14)	0.105 (12)	0.135 (10)	
12	0.8	75	103	166		0.064 (16)
15	1.2	59	82	133	188	0.075 (14)
18	1.8	49	68	110	156	0.075 (14)
21	2.4	42	58	94	134	0.105 (12)
24	3.1	36	50	82	117	0.105 (12)
27	4.0	32	44	73	103	0.105 (12)
30	4.9	28	40	65	93	0.105 (12)
36	7.1	23	33	54	77	0.105 (12)
42	9.6	19	27	46	65	0.105 (12)
48	12.6	16	23	39	57	0.105 (12)
54	16.0	13	20	35	50	0.105 (12)
60	19.6	11	17	31	45	0.105 (12)
66	23.8	9	15	27	40	0.105 (12)
72	28.3	7	13	25	36	0.105 (12)

NOTES:

- COVER HEIGHTS INDICATED IN TABLE ARE FOR FINISHED CONSTRUCTION, USING AASHTO LRFD BRIDGE DESIGN SPECIFICATIONS AND ASSUMING 25% METAL LOSS AT END OF DESIGN LIFE.
- TO PROTECT PIPE DURING CONSTRUCTION, MINIMUM HEIGHT OF COVER TO BE IN ACCORDANCE WITH TABLE A PRIOR TO ALLOWING CONSTRUCTION TRAFFIC TO CROSS INSTALLATION. THE COVER SHALL EXTEND THE FULL LENGTH OF THE PIPE. THE APPROACH FILL RAMP IS TO EXTEND A MINIMUM OF 20 DIAMETERS ON EACH SIDE OF THE PIPE, OR TO THE INTERSECTION WITH A CUT.
- STANDRD MINIMUM FINISHED HEIGHT OF COVER FOR ALL PIPES, EXCEPT THOSE UNDER ENTRANCES, SHALL BE 2'0" OR 1/2 DIAMETER, WHICHEVER IS GREATER. IN CASES IN WHICH THESE COVER HEIGHTS CANNOT BE ACHIEVED, AN ABSOLUTE MINIMUM FINISHED COVER HEIGHT OF 1.0' OR 1/4 DIAMETER, WHICHEVER IS GREATER, WILL BE ALLOWED ONLY IF ALL POSSIBLE MEANS TO OBTAIN THE STANDARD VALUE HAVE BEEN EXHAUSTED. THE MINIMUM FINISHED HEIGHT OF COVER FOR PIPES UNDER ENTRANCES IS 9" FOR PIPE DIAMETERS LESS THAN OR EQUAL TO 18" AND 12" OR 1/4 DIAMETER, WHICHEVER IS GREATER, FOR PIPE DIAMETERS GREATER THAN 18".
- SEE STANDARD PB-1 FOR PIPE BEDDING AND BACKFILL REQUIREMENTS.

PIPE DIAMETER	MINIMUM COVER HEIGHT DURING CONSTRUCTION (SEE NOTE 2)
12" TO 27"	18"
30" AND OVER	EQUAL TO DIAMETER

SPECIFICATION REFERENCE

232
302

A COPY OF THE ORIGINAL SEALED AND SIGNED DRAWING IS ON FILE IN THE CENTRAL OFFICE.

ALUMINUM SPIRAL RIB PIPE
HEIGHT OF COVER TABLE FOR HL-93 LIVE LOAD
VIRGINIA DEPARTMENT OF TRANSPORTATION



ROAD AND BRIDGE STANDARDS

REVISION DATE

11/15

SHEET 12 OF 18

107.16

STEEL SPIRAL RIB PIPE 3/4" WIDE x 3/4" RIBS SPACED @ 7 1/2"

PIPE DIAMETER INCHES	AREA SQ. FT.	MAXIMUM HEIGHT OF COVER IN FEET				MINIMUM SHEET THICKNESS FOR ENTRANCE PIPES WITH LESS THAN 1 FT. COVER INCHES (GAUGE)
		SHEET THICKNESS IN INCHES (GAUGE)				
		0.064 (16)	0.079 (14)	0.109 (12)	0.138 (10)	
18	1.8	101	142			0.064 (16)
21	2.4	86	121	203		0.064 (16)
24	3.1	75	106	177		0.064 (16)
27	4.0	67	94	157		0.064 (16)
30	4.9	60	84	141		0.064 (16)
36	7.1	49	70	117		0.064 (16)
42	9.6	42	59	100		0.064 (16)
48	12.6	36	51	87	127	0.064 (16)
54	16.0		45	77	113	0.079 (14)
60	19.6		40	69	101	0.079 (14)
66	23.8			62	92	0.109 (12)
72	28.3			57	84	0.109 (12)
78	33.2			52	77	0.109 (12)
84	38.6				71	0.138 (10)
90	44.17				66	0.138 (10)

NOTES:

- COVER HEIGHTS INDICATED IN TABLE ARE FOR FINISHED CONSTRUCTION, USING AASHTO LRFD BRIDGE DESIGN SPECIFICATIONS AND ASSUMING 25% METAL LOSS AT END OF DESIGN LIFE.
- TO PROTECT PIPE DURING CONSTRUCTION, MINIMUM HEIGHT OF COVER TO BE IN ACCORDANCE WITH TABLE A PRIOR TO ALLOWING CONSTRUCTION TRAFFIC TO CROSS INSTALLATION. THE COVER SHALL EXTEND THE FULL LENGTH OF THE PIPE. THE APPROACH FILL IS TO EXTEND A MINIMUM OF 15 DIAMETERS ON EACH SIDE OF THE PIPE OR TO THE INTERSECTION WITH THE CUT.
- MINIMUM FINISHED HEIGHT OF COVER FOR ALL PIPES, EXCEPT THOSE UNDER ENTRANCES, SHALL BE 2.0' OR 1/2 DIAMETER, WHICHEVER IS GREATER. IN CASES IN WHICH THESE COVER HEIGHTS CANNOT BE ACHIEVED, AN ABSOLUTE MINIMUM FINISHED COVER HEIGHT OF 1.0' OR 1/4 DIAMETER, WHICHEVER IS GREATER, WILL BE ALLOWED ONLY IF ALL POSSIBLE MEANS TO OBTAIN THE STANDARD VALUE HAVE BEEN EXHAUSTED. THE MINIMUM FINISHED HEIGHT OF COVER FOR PIPES UNDER ENTRANCES IS 9" FOR PIPE DIAMETERS LESS THAN OR EQUAL TO 24" AND 12" OR 1/4 DIAMETER, WHICHEVER IS GREATER, FOR PIPE DIAMETERS GREATER THAN 24". WHERE POLYMER COATED PIPE WILL BE USED AND THE SURFACE OVER THE TOP OF THE PIPE WILL BE ASPHALT, CLASS I BACKFILL MATERIAL IS TO BE PLACED UP TO A MINIMUM OF 6" ABOVE THE TOP OF THE PIPE.
- SEE STANDARD PB-1 FOR PIPE BEDDING AND BACKFILL REQUIREMENTS.
- A MAXIMUM HEIGHT OF COVER TABLE FOR STEEL SPIRAL RIB WITH 3/4" WIDE x 1" DEEP RIBS SPACED AT 11/2" IS AVAILABLE UPON REQUEST.

PIPE DIAMETER	MINIMUM COVER HEIGHT DURING CONSTRUCTION (SEE NOTE 2)
12" TO 30"	18"
36" AND ABOVE	1/2 DIAMETER



ROAD AND BRIDGE STANDARDS

A COPY OF THE ORIGINAL SEALED AND SIGNED STANDARD DRAWING IS ON FILE IN THE CENTRAL OFFICE

STEEL SPIRAL RIB PIPE
HEIGHT OF COVER TABLE FOR HL-93 LIVE LOAD
VIRGINIA DEPARTMENT OF TRANSPORTATION

SPECIFICATION REFERENCE

SHEET 13 OF 18

REVISION DATE

107.17

11/15

232
302

CAST IRON PIPE CULVERT DESIGNATION				
DIAMETER INCHES	AREA SQ. FT.	MAXIMUM HEIGHT OF COVER IN FEET		
		1-13	14-21	22-35 (2)
12 (2)	0.8	STANDARD PIPE	HEAVY PIPE	EXTRA HEAVY PIPE
15 (3)	1.2			
16 (2) (4)	1.4			
18 (1)	1.8			
24 (1)	3.1			
30 (1)	4.9			
36 (1)	7.1			
42 (2)	9.6			
48 (2)	12.6			

- (1) PIPE MAY BE SMOOTH CAST IRON, CORRUGATED CAST IRON, OR RIBBED CAST IRON.
- (2) PIPE TO BE SMOOTH CAST IRON ONLY.
- (3) PIPE TO BE CORRUGATED CAST IRON OR RIBBED CAST IRON.
- (4) MAY BE SUBSTITUTED FOR 15" PIPE CULVERT AT NO INCREASE IN PRICE BID FOR 15" PIPE, WHERE APPROVED BY THE ENGINEER.

NOTES:

- 1. COVER HEIGHTS INDICATED IN TABLES ARE FOR FINISHED CONSTRUCTION WHICH MATCH FORMER VDOT ALLOWABLE STRESS DESIGN TABLES. COVER HEIGHTS WERE NOT RE-CALCULATED USING LRFD
- 2. TO PROTECT PIPE DURING CONSTRUCTION, MINIMUM HEIGHT OF COVER PRIOR TO ALLOWING CONSTRUCTION TRAFFIC TO CROSS INSTALLATION IS TO BE 24". THIS COVER IS TO EXTEND THE FULL LENGTH OF THE PIPE CULVERT. THE APPROACH FILL RAMP IS TO EXTEND A MINIMUM OF 10 (DIAMETER + 36") ON EACH SIDE OF THE CULVERT, OR TO THE INTERSECTION WITH A CUT.
- 3. MINIMUM FINISHED HEIGHT OF COVER TO BE 24", EXCEPT PIPE UNDER ENTRANCES AND MEDIAN CROSSOVERS WHERE A 9" MINIMUM WILL BE PERMITTED.
- 4. SEE STANDARD PB-1 FOR PIPE BEDDING AND BACKFILL REQUIREMENTS.

SPECIFICATION REFERENCE
232 302

A COPY OF THE ORIGINAL SEALED AND SIGNED STANDARD DRAWING IS ON FILE IN THE CENTRAL OFFICE

CAST IRON PIPE
HEIGHT OF COVER TABLE FOR HL-93 LIVE LOAD
 VIRGINIA DEPARTMENT OF TRANSPORTATION

VDOT ROAD AND BRIDGE STANDARDS	
REVISION DATE	SHEET 14 OF 18
11/15	107.18

POLYETHYLENE CORRUGATED PIPE (PE)

(SEE NOTE 5)

DIAMETER INCHES	AREA SQ. FT.	MAXIMUM HEIGHT OF COVER FEET
12	0.8	24
15	1.2	24
18	1.8	20
24	3.1	20
30	4.9	19
36	7.1	18
42	9.6	18
48	12.6	17
54	15.9	16
60	19.6	16

NOTES:

- COVER HEIGHTS INDICATED IN TABLES ARE FOR FINISHED CONSTRUCTION, USING AASHTO LRFD BRIDGE DESIGN SPECIFICATIONS.
- TO PROTECT PIPE DURING CONSTRUCTION, MINIMUM HEIGHT OF COVER TO BE IN ACCORDANCE WITH TABLE A PRIOR TO ALLOWING CONSTRUCTION TRAFFIC TO CROSS INSTALLATION. THE COVER SHALL EXTEND THE FULL LENGTH OF THE PIPE. THE APPROACH FILL IS TO EXTEND A MINIMUM OF 10(DIAMETER + 1/2 DIAMETER) ON EACH SIDE OF THE PIPE OR TO THE INTERSECTION WITH A CUT.
- STANDARD MINIMUM FINISHED HEIGHT OF COVER FOR ALL PIPES, EXCEPT THOSE UNDER ENTRANCES, SHALL BE 2.0' OR 1/2 DIAMETER WHICHEVER IS GREATER. FOR 12" THROUGH 48" DIAMETER PIPE INSTALLATIONS WHERE THE COVER HEIGHTS CANNOT BE ACHIEVED, AN ABSOLUTE MINIMUM FINISHED COVER HEIGHT OF 1.0' WILL BE ALLOWED ONLY IF ALL POSSIBLE MEANS TO OBTAIN THE STANDARD VALUE HAVE BEEN EXHAUSTED. THE MINIMUM FINISHED HEIGHT OF COVER FOR PIPES UNDER ENTRANCES IS 9" FOR PIPE DIAMETERS LESS THAN OR EQUAL TO 24", AND 12" FOR PIPE DIAMETERS GREATER THAN 24". WHERE THE SURFACE OVER THE TOP OF THE PIPE WILL BE ASPHALT, A MINIMUM OF 6" OF CLASS 1 BACKFILL MATERIAL IS TO BE PLACED BETWEEN THE TOP OF THE PIPE AND THE BOTTOM OF THE ASPHALT.
- SEE STANDARD PB-1 FOR PIPE BEDDING AND BACKFILL REQUIREMENTS.
- HEIGHT OF COVER VALUES FOR 12" THROUGH 36" DIAMETER APPLY TO TYPE C OR S. HEIGHT OF COVER VALUES FOR 42" THROUGH 60" APPLY TO TYPE S ONLY.
- HEIGHT OF COVER VALUES FOR 12" THROUGH 30" DIAMETER APPLY TO TYPE S. HEIGHT OF COVER VALUES FOR 36" THROUGH 60" APPLY TO TYPE D.
- LARGE CULVERTS SHALL BE DESIGNED BY AN ENGINEER, REGISTERED IN THE COMMONWEALTH OF VIRGINIA, AND SHALL BE DESIGNED IN ACCORDANCE WITH THE REQUIREMENTS OF VOLUME V, PART 2 OF THE MANUAL OF THE STRUCTURE AND BRIDGE DIVISION. A LARGE CULVERT IS ANY CULVERT THAT WILL BECOME PART OF THE STRUCTURE AND BRIDGE INVENTORY. THE GEOMETRIC DEFINITION OF THESE STRUCTURES IS PROVIDED IN THE CURRENT VERSION OF VDOT'S IM-S&B-27.

POLYVINYLCHLORIDE PROFILE WALL PIPE (PVC)

DIAMETER INCHES	AREA SQ. FT.	MAXIMUM HEIGHT OF COVER FEET
18	1.7	41
21	2.3	40
24	3.0	37
30	4.7	34
36	6.9	34

POLYPROPYLENE PIPE (PP)

(SEE NOTE 6)

DIAMETER INCHES	AREA SQ. FT.	MAXIMUM HEIGHT OF COVER FEET
12	0.8	25
15	1.2	25
18	1.8	21
24	3.1	20
30	4.9	19
36	7.1	18
42	9.6	18
48	12.6	17
60	19.6	17

TABLE A

PIPE DIAMETER	MINIMUM COVER HEIGHT DURING CONSTRUCTION (SEE NOTE 2)
12" TO 30"	18"
36" AND ABOVE	1/2 DIAMETER



ROAD AND BRIDGE STANDARDS

A COPY OF THE ORIGINAL SEALED AND SIGNED STANDARD DRAWING IS ON FILE IN THE CENTRAL OFFICE

**PLASTIC PIPE
HEIGHT OF COVER TABLES FOR HL-93 LIVE LOAD**
VIRGINIA DEPARTMENT OF TRANSPORTATION

SPECIFICATION
REFERENCE

SHEET 15 OF 18

REVISION DATE

107.19

11/15

232
302

TABLE A - ALLOWABLE TYPE OF PIPE CULVERT FOR ROADWAYS THAT ARE CONSTRUCTED, FUNDED OR WILL ULTIMATELY BE MAINTAINED BY VDOT					
FUNCTIONAL CLASSIFICATION OF ROADS SYSTEM UNDER WHICH PIPE IS TO BE INSTALLED					ENTRANCE PIPE
HIGHER FUNCTIONAL CLASS - HFC 75 - YEAR DESIGN LIFE RURAL PRINCIPAL ARTERIAL, URBAN PRINCIPAL ARTERIAL, RURAL MINOR ARTERIAL, URBAN MINOR ARTERIAL, RURAL COLLECTOR ROADS, URBAN COLLECTOR STREETS, SUBDIVISION STREETS WITH AN ADT GREATER THAN 4000			LOWER FUNCTIONAL CLASS - LFC 50 - YEAR DESIGN LIFE RURAL LOCAL ROADS, URBAN LOCAL STREETS, SUBDIVISION STREETS WITH AN ADT LESS THAN OR EQUAL TO 4000		
ALLOWABLE PIPE CULVERTS NOTES 1 & 2	STATEWIDE EXCEPT LOCATIONS SHOWN IN TABLE B	LOCATION SHOWN IN TABLE B	STATEWIDE EXCEPT LOCATIONS SHOWN IN TABLE B	LOCATION SHOWN IN TABLE B	STATEWIDE
CONCRETE	✓	✓	✓	✓	✓
ALUMINUM COATED TYPE 2 CORRUGATED STEEL NOTE 3	✓		✓		✓
POLYMER COATED (10/10) CORRUGATED STEEL NOTE 3	✓	✓	✓	✓	✓
UNCOATED GALVANIZED CORRUGATED STEEL NOTES 3 & 4					✓
GALVANIZED STEEL STRUCTURAL PLATE NOTE 3			✓		✓
GALVANIZED STEEL STRUCTURAL PLATE WITH THICKENED INVERT NOTE 3, 5	✓		✓	✓	✓
CORRUGATED ALUMINUM ALLOY NOTE 3	✓	✓	✓	✓	✓
CORRUGATED ALUMINUM ALLOY STRUCTUAL PLATE NOTE 3	✓	✓	✓	✓	✓
POLYVINYLCHLORIDE (PVC) PROFILE WALL PIPE (SMOOTH INTERIOR)	✓	✓	✓	✓	✓
POLYETHYLENE (PE) CORRUGATED TYPE C	✓	✓	✓	✓	
POLYETHYLENE (PE) CORRUGATED TYPE S	✓	✓	✓	✓	✓
POLYPROPYLENE (PP) TYPE D OR S	✓	✓	✓	✓	✓

NOTES:

1. ALLOWABLE TYPES OF PIPES FOR A SPECIFIC AREA ARE TO CONFORM TO THE CRITERIA SHOWN IN TABLES A, A1, B, AND C. ANY DEVIATION MUST BE APPROVED BY THE STATE LOCATION AND DESIGN ENGINEER AND THE DISTRICT MATERIALS ENGINEER.
2. SEE HEIGHT OF COVER TABLES FOR MINIMUM AND MAXIMUM COVER LIMITATIONS FOR EACH TYPE OF PIPE.
3. SEE TABLE C FOR MINIMUM AND MAXIMUM pH, RESISTIVITY, AND VELOCITY LIMITATIONS FOR METAL PIPES. SEE TABLE D FOR REQUIRED GAUGE OF METAL PIPE.
4. USE ONLY UNDER ENTRANCES WHERE THE PIPE SIZE IS LESS THAN OR EQUAL TO 30" DIAMETER (OR EQUIVALENT) AND THE HEIGHT OF COVER IS LESS THAN OR EQUAL TO 15' AND AS AN OUTLET PIPE FOR STANDARD DI-13 SHOULDER SLOT INLETS.
5. BOTTOM AND CORNER PLATES SHALL BE 2 GAUGE STEPS THICKER

SPECIFICATION REFERENCE	A COPY OF THE ORIGINAL SEALED AND SIGNED STANDARD DRAWING IS ON FILE IN THE CENTRAL OFFICE	 ROAD AND BRIDGE STANDARDS	
232 302	<p align="center"> ALLOWABLE PIPE CRITERIA FOR CULVERT AND STORM SEWERS VIRGINIA DEPARTMENT OF TRANSPORTATION </p>	11/15	107.20

TABLE A1 - ALLOWABLE TYPE OF STORM SEWER PIPE FOR ROADWAYS THAT ARE CONSTRUCTED, FUNDED OR WILL ULTIMATELY BE MAINTAINED BY VDOT			
FUNCTIONAL CLASSIFICATION OF ROADS SYSTEM UNDER WHICH PIPE IS TO BE INSTALLED			
HIGHER FUNCTIONAL CLASS - HFC 75 - YEAR DESIGN LIFE		LOWER FUNCTIONAL CLASS - LFC 50 - YEAR DESIGN LIFE	
RURAL PRINCIPAL ARTERIAL, URBAN PRINCIPAL ARTERIAL, RURAL MINOR ARTERIAL, URBAN MINOR ARTERIAL, RURAL COLLECTOR ROADS, URBAN COLLECTOR STREETS, SUBDIVISION STREETS WITH AN ADT GREATER THAN 4000		RURAL LOCAL ROADS, URBAN LOCAL STREETS, SUBDIVISION STREETS WITH AN ADT LESS THAN OR EQUAL TO 4000	
ALLOWABLE PIPE CULVERTS	STATEWIDE	STATEWIDE EXCEPT LOCATIONS SHOWN IN TABLE B	LOCATION SHOWN IN TABLE B
NOTES 1 & 2			
CONCRETE	✓	✓	✓
ALUMINUM COATED TYPE 2 STEEL SPIRAL RIB		✓	
NOTE 3			
POLYMER COATED (10/10) CORRUGATED STEEL SPIRAL RIB		✓	✓
NOTE 3			
POLYMER COATED (10/10) CORRUGATED STEEL DOUBLE WALL (SMOOTH INTERIOR)	✓	✓	✓
NOTE 3			
ALUMINUM SPIRAL RIB		✓	✓
NOTE 3			
POLYVINYLCHLORIDE (PVC) PROFILE WALL PIPE (SMOOTH INTERIOR)	✓	✓	✓
POLYETHYLENE (PE) CORRUGATED TYPE S	✓	✓	✓
POLYPROPYLENE (PP) TYPE D OR S	✓	✓	✓

TABLE B EXCEPTIONS TO STATEWIDE APPLICATIONS		
COUNTIES (INCLUDING TOWNS)	CITIES	
ARLINGTON - EAST OF AND INCLUDING RTES. 95 & 395	SURRY - EAST OF AND INCLUDING RTE. 10	SUFFOLK - EAST OF AND INCLUDING RTE. 32
FAIRFAX - EAST OF AND INCLUDING RTES. 95 & 395	ISLE OF WIGHT - EAST OF AND INCLUDING RTE. 10	CHESAPEAKE WILLIAMSBURG VIRGINIA BEACH POQUOSON
PRINCE WILLIAM - EAST OF AND INCLUDING RTES. 95 & 395		HAMPTON PORTSMOUTH
WESTMORELAND JAMES CITY	ESSEX NORTHAMPTON	NEWPORT NEWS
LANCASTER ACCOMACK	MIDDLESEX STAFFORD	NORFOLK
MATTHEWS SPOTSYLVANIA	YORK KING GEORGE	ALEXANDRIA
GLOUCESTER NORTHUMBERLAND	RICHMOND	FREDERICKSBURG

TABLE C					
PIPE TYPE	ALLOWABLE pH RANGE (SEE NOTE 6)		ALLOWABLE RESISTIVITY RANGE (Ohms-cm)		ALLOWABLE VELOCITY (FPS) (SEE NOTE 4)
	MIN.	MAX.	MIN.	MAX.	MAXIMUM
UNCOATED GALVANIZED CORRUGATED STEEL	6.0	10.0	2000	10000	5
GALVANIZED STEEL STRUCTURAL PLATE	6.0	9.0	2000	10000	5
GALVANIZED STEEL STRUCTURAL PLATE WITH THICKENED INVERT	6.0	9.0	2000	10000	15
ALUMINUM COATED TYPE 2 CORRUGATED STEEL	5.0	9.0	1500	-	5
ALUMINUM COATED TYPE 2 SPIRAL RIB	5.0	9.0	1500	-	5
CORRUGATED ALUMINUM ALLOY	4.0	9.0	1500	-	5
CORRUGATED ALUMINUM ALLOY STRUCTURAL PLATE	4.0	9.0	1500	-	5
ALUMINUM SPIRAL RIB	4.0	9.0	1500	-	5
POLYMER COATED (10/10) CORRUGATED STEEL	4.0	9.0	750	-	10
POLYMER COATED CORRUGATED STEEL SPIRAL RIB	4.0	9.0	750	-	10
POLYMER COATED CORRUGATED STEEL DOUBLE WALL	4.0	9.0	750	-	10

NOTES:

- ALLOWABLE TYPES OF PIPES FOR A SPECIFIC AREA ARE TO CONFORM TO THE CRITERIA SHOWN IN TABLES A, A1, B, AND C. ANY DEVIATION MUST BE APPROVED BY THE STATE LOCATION AND DESIGN ENGINEER AND THE DISTRICT MATERIALS ENGINEER.
- SEE HEIGHT OF COVER TABLES FOR MINIMUM AND MAXIMUM COVER LIMITATIONS FOR EACH TYPE OF PIPE.
- SEE TABLE C FOR MINIMUM AND MAXIMUM pH, RESISTIVITY, AND VELOCITY LIMITATIONS FOR METAL PIPES. SEE TABLE D FOR REQUIRED GAUGE OF METAL PIPE.
- ALLOWABLE WATER VELOCITY IN PIPE WHERE ABRASIVE BEDLOAD IS PRESENT OR ANTICIPATED. MAXIMUM VELOCITY BASED ON 10 YEAR DESIGN DISCHARGE (Q).
- pH VALUES APPLY TO BOTH THE IN-SITU SOIL AND WATER. THE LESSER OF THE TWO VALUES SHALL APPLY.
- ph OF SOIL - AASHTO T289.
ph OF WATER - ASTM 1293-12 METHOD A
RESISTIVITY (MINIMUM) OF SOIL - AASHTO T288
- LARGE CULVERTS SHALL BE DESIGNED BY AN ENGINEER, REGISTERED IN THE COMMONWEALTH OF VIRGINIA, AND SHALL BE DESIGNED IN ACCORDANCE WITH THE REQUIREMENTS OF VOLUME V, PART 2 OF THE MANUAL OF THE STRUCTURE AND BRIDGE DIVISION. A LARGE CULVERT IS ANY CULVERT THAT WILL BECOME PART OF THE STRUCTURE AND BRIDGE INVENTORY. THE GEOMETRIC DEFINITION OF THESE STRUCTURES IS PROVIDED IN THE CURRENT VERSION OF VDOT'S IIM-S&B-27.

VDOT
ROAD AND BRIDGE STANDARDS

SHEET 17 OF 18	REVISION DATE
107.21	11/15

A COPY OF THE ORIGINAL SEALED AND SIGNED STANDARD DRAWING IS ON FILE IN THE CENTRAL OFFICE

**ALLOWABLE PIPE CRITERIA FOR
CULVERT AND STORM SEWERS**

VIRGINIA DEPARTMENT OF TRANSPORTATION

SPECIFICATION REFERENCE
232 302

TABLE D - REQUIRED METAL GAUGE THICKNESS (AFTER ABRASION CONSIDERATIONS)

TABLE D FOR GALVANIZED STEEL 50-YEAR DESIGN LIFE								
	MINIMUM IN -SITU SOIL RESISTIVITY							
pH *	2000	3000	4000	5000	6000	7000	8000	>9000
6	10	12	12	12	12	12	14	14
6.5	12	12	12	14	14	14	14	16
6.8	12	14	14	14	16	16	16	16
7	14	14	16	16	16	16	16	16
7.1	14	16	16	16	16	16	16	16
≥ 7.2	16	16	16	16	16	16	16	16

TABLE D FOR GALVANIZED STEEL 75-YEAR DESIGN LIFE					
	MINIMUM IN -SITU SOIL RESISTIVITY				
pH *	2000	3000	4000-5000	6000-8000	>9000
6	8	8	10	10	12
6.5	8	10	10	12	12
6.8	10	10	12	12	12
7	10	12	12	12	12
7.1	12	12	12	12	12
≥7.2	12	12	12	12	12

TABLE D FOR ALUMINUM COATED TYPE 2, ALUMINUM ALLOY, AND POLYMER -COATED STEEL 50-YEAR DESIGN LIFE											
	MINIMUM IN -SITU SOIL RESISTIVITY										
pH *	1500	2000	3000	4000	5000	6000	7000	8000	9000	10000	>20000
4	10	10	12	12	12	12	14	14	14	14	16
5	12	12	12	14	14	14	14	16	16	16	16
5.5	12	12	14	14	14	16	16	16	16	16	16
6	12	12	14	14	14	16	16	16	16	16	16
6.5	14	14	14	16	16	16	16	16	16	16	16
6.8	14	14	16	16	16	16	16	16	16	16	16
≥7	16	16	16	16	16	16	16	16	16	16	16

TABLE D FOR ALUMINUM COATED TYPE 2, ALUMINUM ALLOY, AND POLYMER -COATED STEEL 75-YEAR DESIGN LIFE															
	MINIMUM IN -SITU SOIL RESISTIVITY														
pH *	1500	2000	3000	4000	5000	6000	7000	8000	9000	10000	20000	30000	40000	50000	>50000
4	N/A	N/A	8	10	10	10	10	12	12	12	12	12	14	14	14
5	8	8	10	10	12	12	12	12	12	12	12	14	14	14	14
5.5	8	10	12	12	12	12	12	12	12	12	14	14	14	16	16
6	10	10	12	12	12	12	12	12	12	12	14	14	16	16	16
6.5	12	12	12	12	12	12	12	14	14	14	16	16	16	16	16
6.8	12	12	12	12	14	14	14	14	14	14	16	16	16	16	16
7	12	12	14	14	14	14	14	16	16	16	16	16	16	16	16
7.1	12	12	14	14	16	16	16	16	16	16	16	16	16	16	16
7.2	14	14	14	16	16	16	16	16	16	16	16	16	16	16	16
7.3	16	16	16	16	16	16	16	16	16	16	16	16	16	16	16
> 7.3	16	16	16	16	16	16	16	16	16	16	16	16	16	16	16

NOTES:

1. LEVEL 3 ABRASION IS MAXIMUM FOR POLYMER COATED STEEL PIPE AND GALVANIZED STEEL PLATE WITH THICKENED INVERT.
2. LEVEL 2 ABRASION IS MAXIMUM FOR REST OF METAL PIPES.
3. PIPES THAT MEET THE CRITERIA OF TABLES A, B, AND C MAY NOT MEET THE CONSIDERATION OF PARTICLE SIZE OF THE BEDLOAD AS DESCRIBED IN THE FHWA ABRASION REQUIREMENTS.
4. BASED ON pH AND RESISTIVITY REQUIREMENTS THE GAUGE OF PIPE MAY NEED TO BE INCREASED AS NOTED IN THESE TABLES TO ATTAIN THE REQUIRED DESIGN LIFE.

* MINIMUM AND MAXIMUM pH FOR EACH PIPE TYPE IS LISTED IN TABLE C

ABRASION LEVEL DEFINITIONS (FHWA)
LEVEL 1 - NONABRASIVE CONDITIONS, AREAS OF NO BEDLOAD AND VERY LOW VELOCITIES. THIS IS THE CONDITION ASSUMED FROM THE SOIL SIDE OF DRAINAGE PIPES
LEVEL 2 - LOW ABRASIVE CONDITIONS, AREAS OF MINOR BEDLOADS AND VELOCITIES OF 5 ft/s OR LESS.
LEVEL 3 - MODERATE ABRASIVE CONDITIONS, AREAS OF MODERATE BEDLOADS OF SAND AND GRAVEL AND VELOCITIES BETWEEN 5 ft/s AND 15 ft/s.
LEVEL 4 - SEVERE ABRASIVE CONDITIONS, AREAS OF HEAVY BEDLOADS OF SAND, GRAVEL, AND ROCK AND VELOCITIES EXCEEDING 15 ft/s.

SPECIFICATION REFERENCE

232
302

A COPY OF THE ORIGINAL SEALED AND SIGNED STANDARD DRAWING IS ON FILE IN THE CENTRAL OFFICE

ALLOWABLE PIPE CRITERIA FOR CULVERT AND STORM SEWERS

VIRGINIA DEPARTMENT OF TRANSPORTATION



ROAD AND BRIDGE STANDARDS

REVISION DATE

11/15

SHEET 18 OF 18

107.22

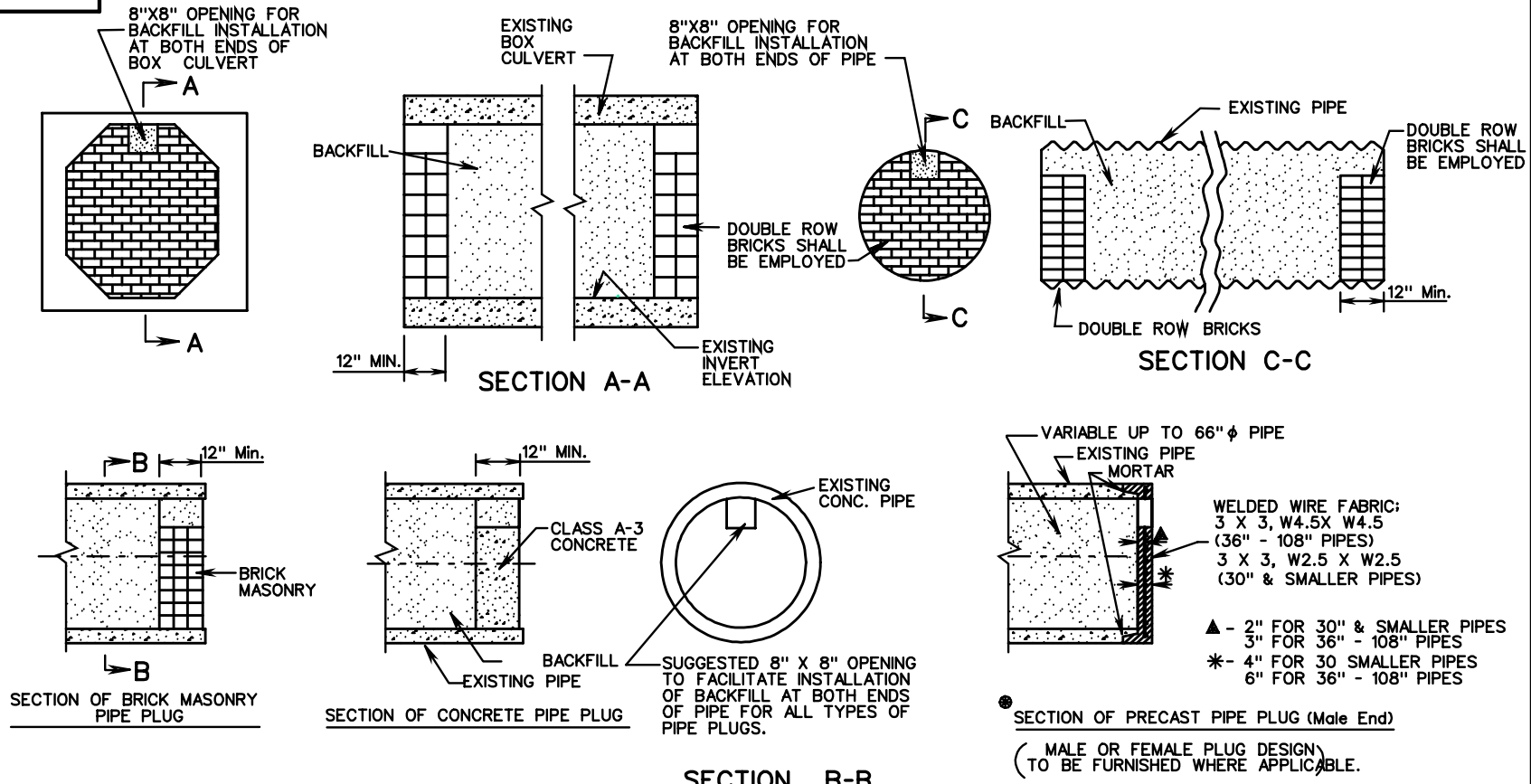

NOTES:

BACKFILL IS TO BE EITHER FLOWABLE BACKFILL OR FINE AGGREGATE AS PER THE SPECIFICATIONS AND IS TO BE PAID AS CUBIC YARDS OF FLOWABLE BACKFILL.

FOR PLACEMENT OF STRUCTURES, SEE ROADWAY PLAN SHEETS.

CONCRETE BRICK MAY BE USED IN LIEU OF CLAY BRICK. JUMBO BRICK WILL BE PERMITTED.

● PRECAST NOTES :

CONCRETE TO BE 4000 P. S. I. MIN. COMPRESSIVE STRENGTH.

CONCRETE AND REINFORCING STEEL SHALL BE IN ACCORDANCE WITH AASHTO M170.

DETAIL SHOWN FOR PRECAST PLUG IS REPRESENTATIVE ONLY, OTHER MANUFACTURER'S DESIGN WILL BE ACCEPTABLE UPON APPROVAL BY THE ENGINEER.

QUANTITIES		
PIPE SIZE	CU.YDS BACKFILL PER LINEAR FOOT	CU.YDS PER EACH CONC. PLUG
12"	0.029	.013
15"	0.045	.029
18"	0.065	.049
24"	0.116	.100
30"	0.182	.166
36"	0.262	.246
42"	0.356	.340
48"	0.465	.449
54"	0.589	.573
60"	0.727	.711
66"	0.880	.864
72"	1.047	1.031
78"	1.229	1.213
84"	1.425	1.409
90"	1.636	1.620
96"	1.862	1.846
102"	2.102	2.086
108"	2.356	2.340



ROAD AND BRIDGE STANDARDS

DETAILS FOR BACKFILLING ABANDONED CULVERTS

SPECIFICATION REFERENCE

SHEET 1 OF 1

REVISION DATE

VIRGINIA DEPARTMENT OF TRANSPORTATION

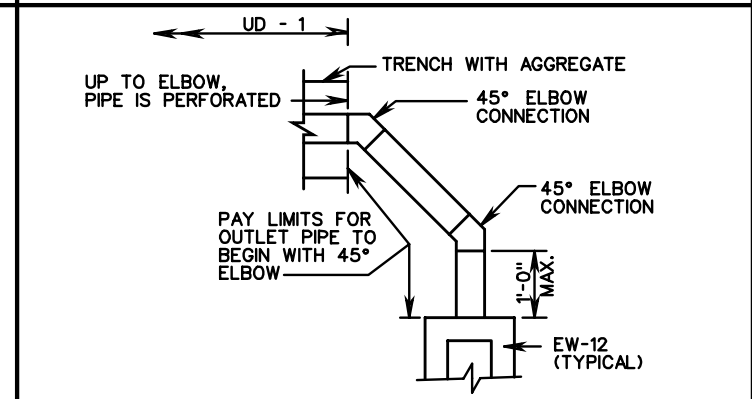
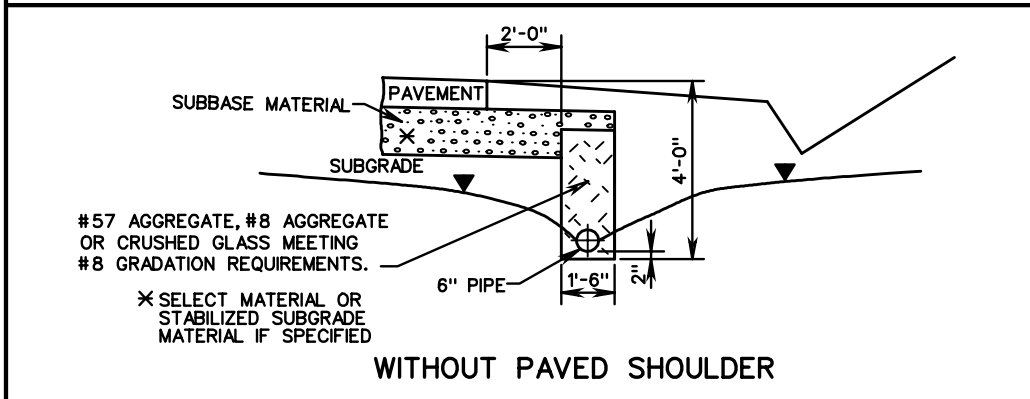
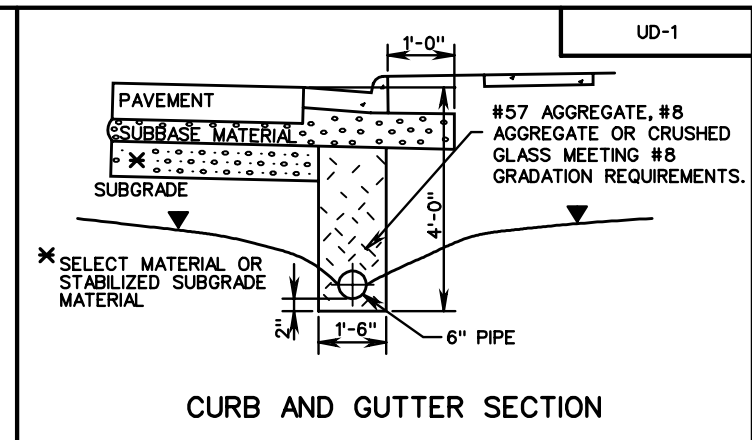
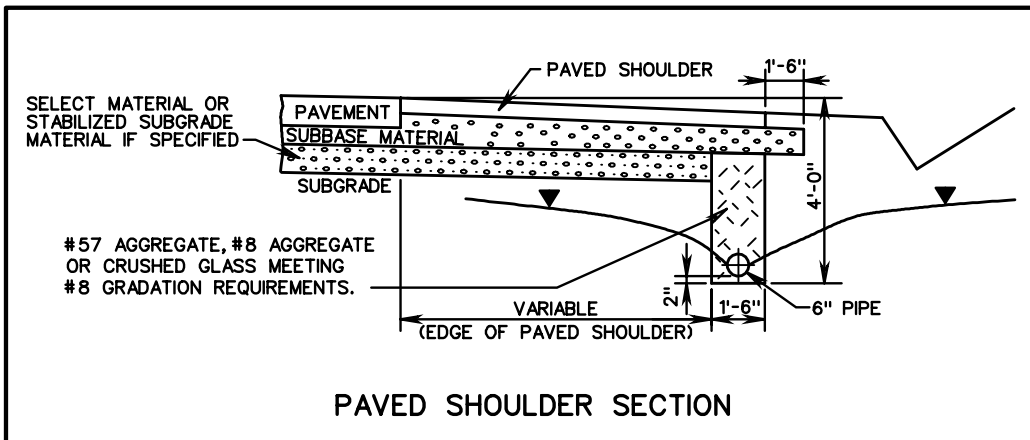

NOTES:

1. WHEN THE LONGITUDINAL PIPE CONNECTS DIRECTLY INTO A DRAINAGE STRUCTURE (DROP INLET, MANHOLE, ECT.), NON-PERFORATED OUTLET PIPES ARE NOT REQUIRED.
2. INVERT ELEVATION AT OUTLET END OF OUTLET PIPE TO BE A MINIMUM OF 1'-0" ABOVE INVERT ELEVATION OF RECEIVING DRAINAGE DITCH OR STRUCTURE.
3. ALL CONNECTIONS (ELBOWS, WYES, ETC.) WITHIN PAY LIMITS FOR OUTLET PIPE ARE TO BE OF THE SAME CRUSHING STRENGTH AS THE OUTLET PIPE.
4. OUTLET PIPE ARE TO BE INSTALLED ON 2% MIN. (3% DESIRABLE) GRADE.
5. THE NORMAL DEPTH OF UNDERDRAIN IS TO BE 4'-0" BELOW THE NEAR EDGE OF PAVEMENT AS SHOWN. THE LONGITUDINAL GRADE OF THE UNDERDRAIN SHALL FOLLOW THAT OF THE ROADWAY WITH A MINIMUM GRADE OF 0.2%.
6. WHERE THE BOTTOM OF SELECT MATERIAL IS GREATER THAN 4'-0" BELOW THE PAVEMENT, THE BOTTOM OF THE UNDERDRAIN IS TO BE COINCIDENT WITH THE BOTTOM OF SELECT MATERIAL AND THE TRENCH DEPTH AND BACKFILL QUANTITY INCREASED ACCORDINGLY.
7. WHEN USED WITH STABILIZED OPEN-GRADED DRAINAGE LAYER, THE BOTTOM OF THE CURB AND GUTTER SHALL BE CONSTRUCTED PARALLEL TO THE SLOPE OF SUBBASE COURSES OUT TO THE DEPTH OF THE PAVEMENT.
8. OUTLET PIPE TO BE SECURELY CONNECTED TO EW-12 OR OTHER DRAINAGE STRUCTURE.
9. ▼ DENOTES WATER TABLE.
10. OUTLET PIPE CONFIGURATION TO PROVIDE FOR PASSAGE OF INSPECTION CAMERA WITH 2 1/2" I. D. HEAD.

LONGITUDINAL PERFORATED PIPE

TYPE OF PIPE	CRUSHING STRENGTH	
	W.T.	6" NOMINAL DIAMETER
SMOOTH WALL PVC	.153	
CORRUGATED PE		AASHTO M-252

NON-PERFORATED OUTLET PIPE

TYPE OF PIPE	CRUSHING STRENGTH	
	W.T.	6" NOMINAL DIAMETER
SMOOTH WALL PVC	.153	
SMOOTH WALL PE		70 PSI ***

× WALL THICKNESS (MIN) - INCHES
 *** TESTED ACCORDING TO ASTM D-2412 AT 5% DEFLECTION.

SPECIFICATION REFERENCE
240
501
701

STANDARD GROUNDWATER UNDERDRAIN

VIRGINIA DEPARTMENT OF TRANSPORTATION

VDOT ROAD AND BRIDGE STANDARDS	
REVISION DATE	SHEET 1 OF 1
	108.01

LONGITUDINAL PERFORATED PIPE

TYPE OF PIPE	CRUSHING STRENGTH	
	× W.T.	6" NOMINAL DIAMETER
SMOOTH WALL PVC	0.153	
CORRUGATED PE		AASHTO M-252

NON-PERFORATED OUTLET PIPE

TYPE OF PIPE	CRUSHING STRENGTH	
	× W.T.	6" NOMINAL DIAMETER
SMOOTH WALL PVC	0.153	
SMOOTH WALL PE		70 PSI ×××

× WALL THICKNESS (MIN) - INCHES
 ××× TESTED ACCORDING TO ASTM D-2412 AT 5% DEFLECTION.

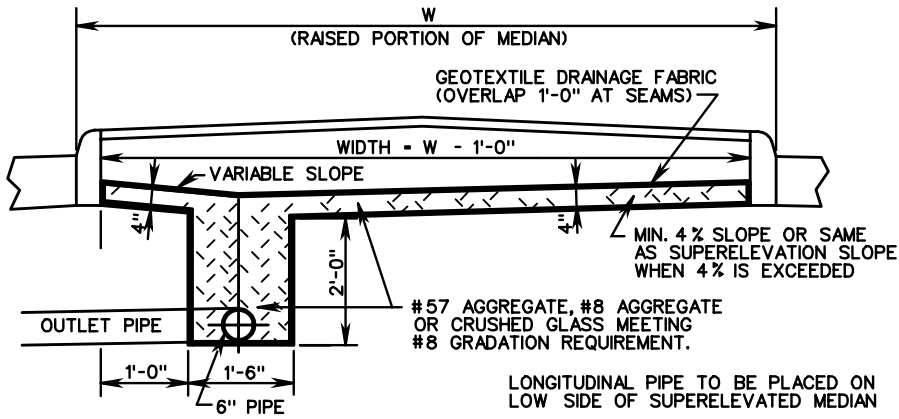

WITHOUT SUBBASE MATERIAL

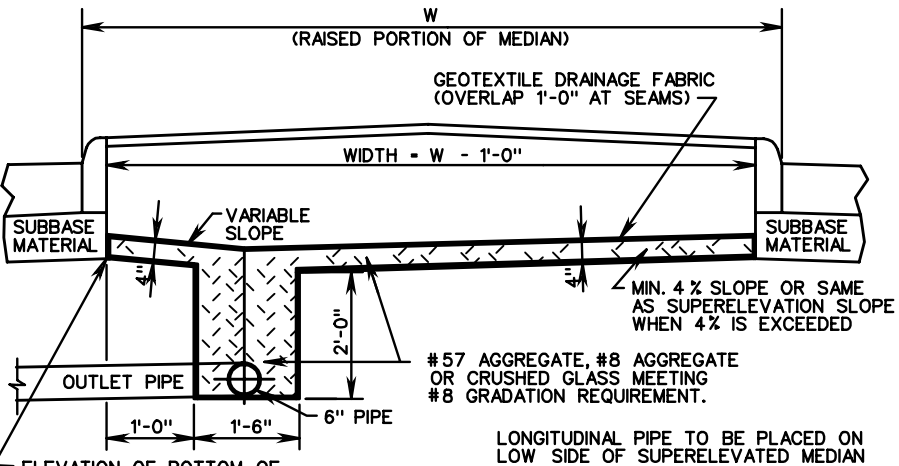

WITH SUBBASE MATERIAL

NOTES:

1. WHEN THE LONGITUDINAL PIPE CONNECTS DIRECTLY INTO A DRAINAGE STRUCTURE (DROP INLET, MANHOLE, ECT.), NON-PERFORATED OUTLET PIPES ARE NOT REQUIRED.
2. INVERT ELEVATION AT OUTLET END OF OUTLET PIPE TO BE A MINIMUM OF 1'-0" ABOVE INVERT ELEVATION OF RECEIVING DRAINAGE DITCH OR STRUCTURE.
3. ALL CONNECTIONS (ELBOWS, WYES, ETC.) WITHIN PAY LIMITS FOR OUTLET PIPE ARE TO BE OF THE SAME CRUSHING STRENGTH AS THE OUTLET PIPE.
4. OUTLET PIPE ARE TO BE INSTALLED ON 2% MIN. (3% DESIRABLE) GRADE AND LOCATED AT A MAXIMUM OF 500' APART.
5. OUTLET PIPE TO BE SECURELY CONNECTED TO EW-12OR OTHER DRAINAGE STRUCTURE.
6. WHEN UNDERDRAIN MUST TRAVERSE UNDER CROSSOVER LOCATIONS, NON-PERFORATED OUTLET PIPE ONLY IS TO BE USED UNDER CROSSOVER PAVEMENT.

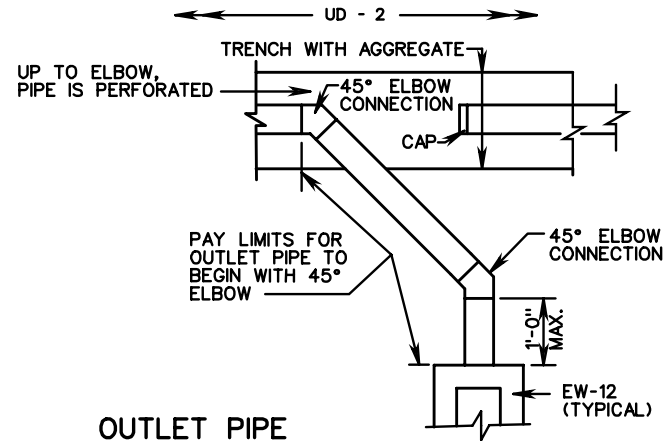

OUTLET PIPE



ROAD AND BRIDGE STANDARDS

SHEET 1 OF 1

REVISION DATE

108.02

STANDARD UNDERDRAIN FOR USE WITH RAISED GRASS MEDIAN STRIPS

VIRGINIA DEPARTMENT OF TRANSPORTATION

SPECIFICATION REFERENCE

240
501
701

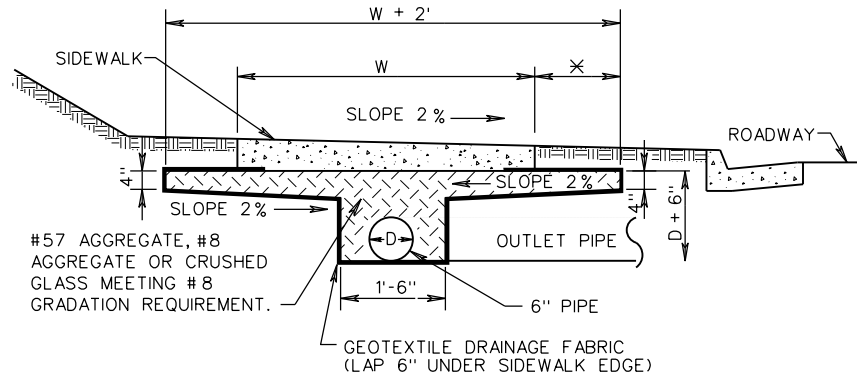

#57 AGGREGATE, #8 AGGREGATE OR CRUSHED GLASS MEETING #8 GRADATION REQUIREMENT.

GEOTEXTILE DRAINAGE FABRIC (LAP 6" UNDER SIDEWALK EDGE)

* THIS PORTION TO BE DELETED WHEN SIDEWALK IS ADJACENT TO CURB OR CURB AND GUTTER WITH NO BUFFER STRIP.

NOTES:

1. WHEN THE LONGITUDINAL PIPE CONNECTS DIRECTLY INTO A DRAINAGE STRUCTURE (DROP INLET, MANHOLE, ECT.), NON-PERFORATED OUTLET PIPES ARE NOT REQUIRED.
2. INVERT ELEVATION AT OUTLET END OF OUTLET PIPE TO BE A MINIMUM OF 1'-0" ABOVE INVERT ELEVATION OF RECEIVING DRAINAGE DITCH OR STRUCTURE.
3. ALL CONNECTIONS (ELBOWS, WYES, ETC.) WITHIN PAY LIMITS FOR OUTLET PIPE ARE TO BE OF THE SAME CRUSHING STRENGTH AS THE OUTLET PIPE.
4. OUTLET PIPE ARE TO BE INSTALLED ON 2% MIN. (3% DESIRABLE) GRADE.
5. OUTLET PIPE TO BE SECURELY CONNECTED TO EW-12 OR OTHER DRAINAGE STRUCTURE.
6. SIDEWALK UNDERDRAIN IS TO BE USED WHEN THE SIDEWALK LONGITUDINAL GRADIENT IS 3% OR MORE AND WHEN THE UNDERLYING SOIL HAS 34% OR MORE PASSING THE NO. 200 SIEVE, AND HAS A P10F 13 OR LESS, AND THE AREA HAS A HISTORY OF SIDEWALK UNDERMINING.
7. SIDEWALK UNDERDRAINS SHOULD BE TIED INTO THE STORM SEWER SYSTEM AT POINTS APPROXIMATELY A CITY BLOCK APART. UNDERDRAIN RUNS MUST NOT EXCEED 1,000 FEET IN LENGTH WITHOUT DISCHARGING INTO THE STORM DRAIN SYSTEM OR INTO AN OPEN DRAIN.
8. WITHIN THE LIMITS OF A COMMERCIAL ENTRANCE, NON-PERFORATED PIPE SHALL BE UTILIZED IN LIEU OF PERFORATED PIPE.

LONGITUDINAL PERFORATED PIPE

TYPE OF PIPE	CRUSHING STRENGTH	
	* W.T.	6" NOMINAL DIAMETER
SMOOTH WALL PVC	0.153	
CORRUGATED PE		AASHTO M-252

NON-PERFORATED PIPE FOR USE UNDER COMMERCIAL ENTRANCES AND FOR OUTLETS

TYPE OF PIPE	CRUSHING STRENGTH	
	* W.T.	6" NOMINAL DIAMETER
SMOOTH WALL PVC	0.153	
SMOOTH WALL PE		70 PSI ***

* WALL THICKNESS (MIN) - INCHES
 *** TESTED ACCORDING TO ASTM D-2412 AT 5% DEFLECTION.

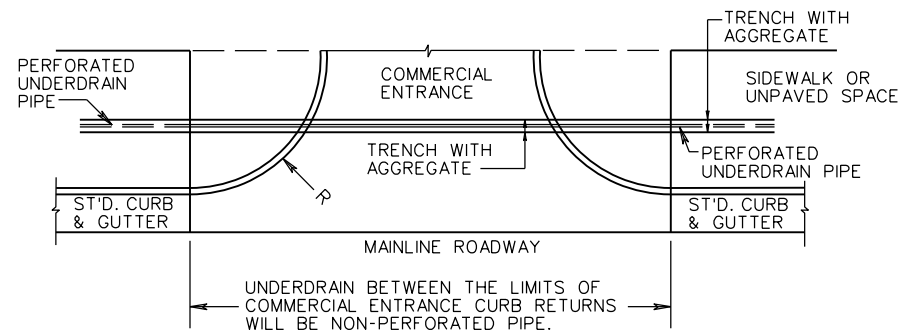
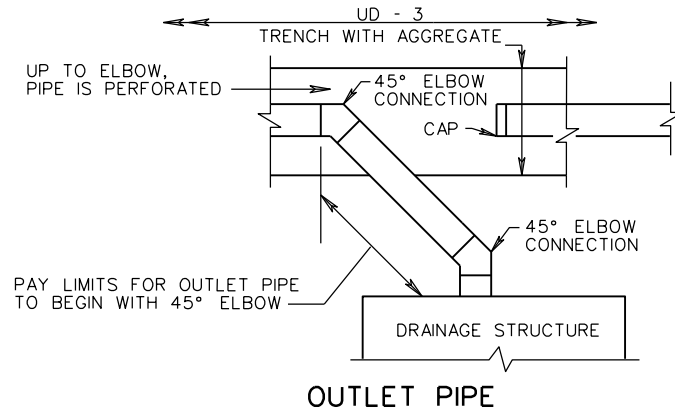

SPECIFICATION REFERENCE

STANDARD SIDEWALK UNDERDRAIN

VIRGINIA DEPARTMENT OF TRANSPORTATION



ROAD AND BRIDGE STANDARDS

REVISION DATE

SHEET 1 OF 1

108.03

CD-1

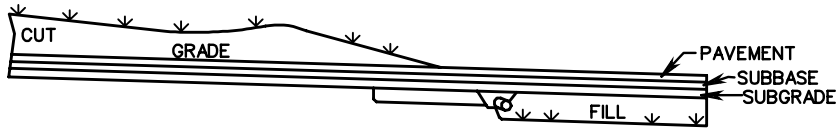

**COMBINATION UNDERDRAIN CD-1 AT LOWER END OF CUTS
CENTER LINE SECTION
(WITH TYPE I SELECT MATERIAL)**

TRENCH PLACEMENT

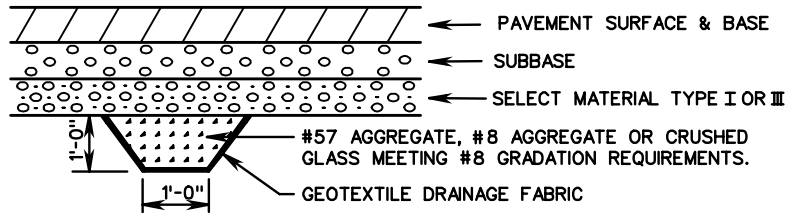

OR

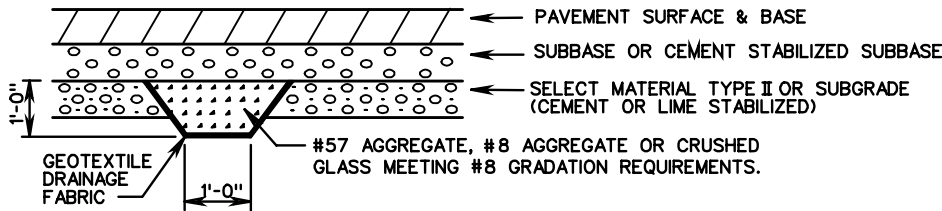

NON-PERFORATED OUTLET PIPE

TYPE OF PIPE	CRUSHING STRENGTH			
	W.T.	4" NOM. DIAMETER	W.T.	6" NOM. DIAMETER
SMOOTH WALL PVC	.103		0.153	
SMOOTH WALL PE		70 PSI ***		70 PSI ***

✕ WALL THICKNESS (MIN) - INCHES
 *** TESTED ACCORDING TO ASTM D-2412 AT 5% DEFLECTION.

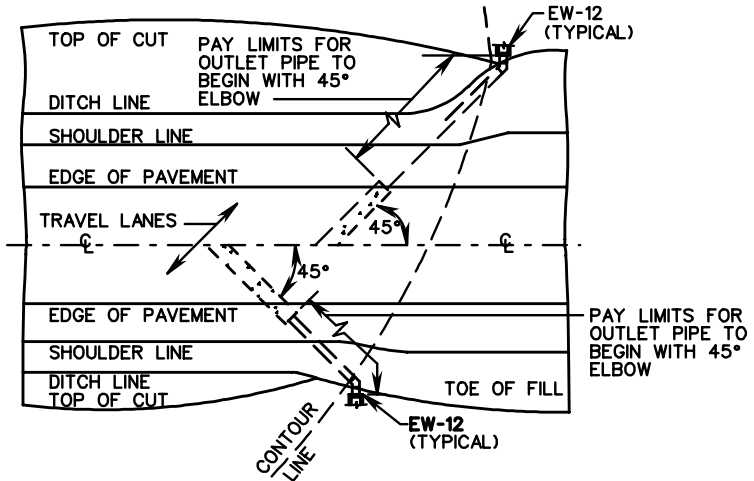

**PLAN VIEW
(PLACEMENT OF CD-1 COMBINATION UNDERDRAIN)**

GENERAL NOTES

- UNLESS SPECIFICALLY INDICATED, COMBINATION UNDERDRAIN WILL NOT BE LOCATED AT THIS POINT WHEN BOTH SUBBASE AND SUBGRADE ARE STABILIZED.
- TRENCH SHALL BE FILLED WITH AGGREGATE AND THOROUGHLY HAND TAMPED TO INSURE COMPACTNESS.
- OUTLET PIPE SHALL BEGIN AT THE EDGE OF THE TRAVEL LANE PAVEMENT AND SHALL BE PLACED ON A GRADE PARALLEL TO THE SHOULDER SLOPE 2% MIN. (3% DESIRABLE) GRADE.
- ON CURB AND GUTTER SECTIONS, WHERE IT IS IMPOSSIBLE TO OTHERWISE PROVIDE OUTLETS FOR UNDERDRAINS, THEY ARE TO BE LOCATED SO AS TO DRAIN INTO DROP INLETS OR MANHOLES.
- ON SUPERELEVATED SECTIONS, TRENCH IS TO BE UNDER ENTIRE PAVEMENT AREA WITH OUTLET PIPE ON LOW SIDE ONLY.
- INVERT ELEVATION AT OUTLET END OF OUTLET PIPE TO BE A MINIMUM OF 1'-0" ABOVE INVERT ELEVATION OF RECEIVING DRAINAGE DITCH OR STRUCTURE.
- ALL CONNECTIONS (ELBOWS, WYES, ETC.) WITHIN PAY LIMITS FOR OUTLET PIPE ARE TO BE OF THE SAME CRUSHING STRENGTH AS THE OUTLET PIPE.
- OUTLET PIPE TO BE SECURELY CONNECTED TO EW-12 OR OTHER DRAINAGE STRUCTURE.



ROAD AND BRIDGE STANDARDS

SHEET 1 OF 1

REVISION DATE

108.04

STANDARD COMBINATION UNDERDRAIN

(AT LOWER END OF CUTS)

VIRGINIA DEPARTMENT OF TRANSPORTATION

SPECIFICATION REFERENCE

232
501
701

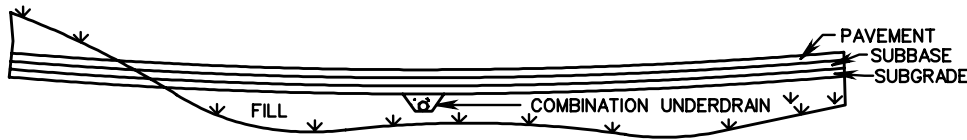

**COMBINATION UNDERDRAIN CD-2 ON FILLS
CENTER LINE SECTION
(WITH TYPE I SELECT MATERIAL)**

TRENCH PLACEMENT

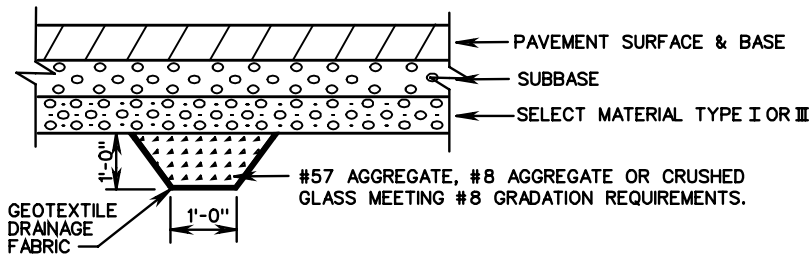

OR

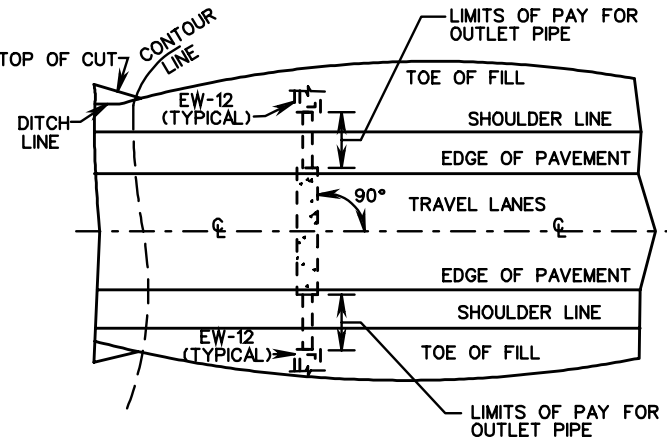
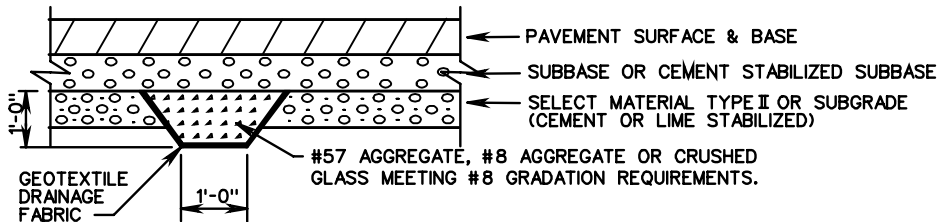

**PLAN VIEW SHOWING PLACEMENT OF
CD-2 UNDERDRAIN**

NON-PERFORATED OUTLET PIPE

TYPE OF PIPE	CRUSHING STRENGTH			
	× W.T.	4" NOM. DIAMETER	× W.T.	6" NOM. DIAMETER
SMOOTH WALL PVC	.103		0.163	
SMOOTH WALL PE		70 PSI ×××		70 PSI ×××

× WALL THICKNESS (MIN) - INCHES
××× TESTED ACCORDING TO ASTM D-2412 AT 5% DEFLECTION.

GENERAL NOTES

1. TRENCH SHALL BE FILLED WITH AGGREGATE AND THOROUGHLY HAND TAMPED TO INSURE COMPACTNESS.
2. OUTLET PIPE SHALL BEGIN AT THE EDGE OF THE TRAVEL LANE PAVEMENT AND SHALL BE PLACED ON A GRADE PARALLEL TO THE SHOULDER SLOPE 2% MIN. (.3% DESIRABLE) GRADE.
3. ON CURB AND GUTTER SECTIONS, WHERE IT IS IMPOSSIBLE TO OTHERWISE PROVIDE OUTLETS FOR UNDERDRAINS, THEY ARE TO BE LOCATED SO AS TO DRAIN INTO DROP INLETS OR MANHOLES.
4. ON SUPERELEVATED SECTIONS, TRENCH IS TO BE UNDER ENTIRE PAVEMENT AREA WITH OUTLET PIPE ON LOW SIDE ONLY.
5. INVERT ELEVATION AT OUTLET END OF OUTLET PIPE TO BE A MINIMUM OF 1'-0" ABOVE INVERT ELEVATION OF RECEIVING DRAINAGE DITCH OR STRUCTURE.
6. ALL CONNECTIONS (ELBOWS, WYES, ETC.) WITHIN PAY LIMITS FOR OUTLET PIPE ARE TO BE OF THE SAME CRUSHING STRENGTH AS THE OUTLET PIPE.
7. OUTLET PIPE TO BE SECURELY CONNECTED TO EW-12 OR OTHER DRAINAGE STRUCTURE.

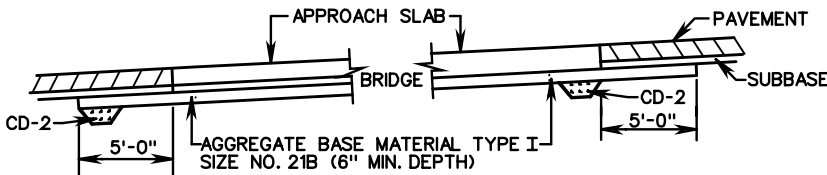

**PLACEMENT OF CD-2 UNDERDRAIN AT
BRIDGE APPROACH SLABS**

SPECIFICATION
REFERENCE

232
501
701

**STANDARD COMBINATION UNDERDRAIN
(AT GRADE SAGS AND BRIDGE APPROACHES)**

VIRGINIA DEPARTMENT OF TRANSPORTATION

VDOT

ROAD AND BRIDGE STANDARDS

REVISION DATE

SHEET 1 OF 1

108.05

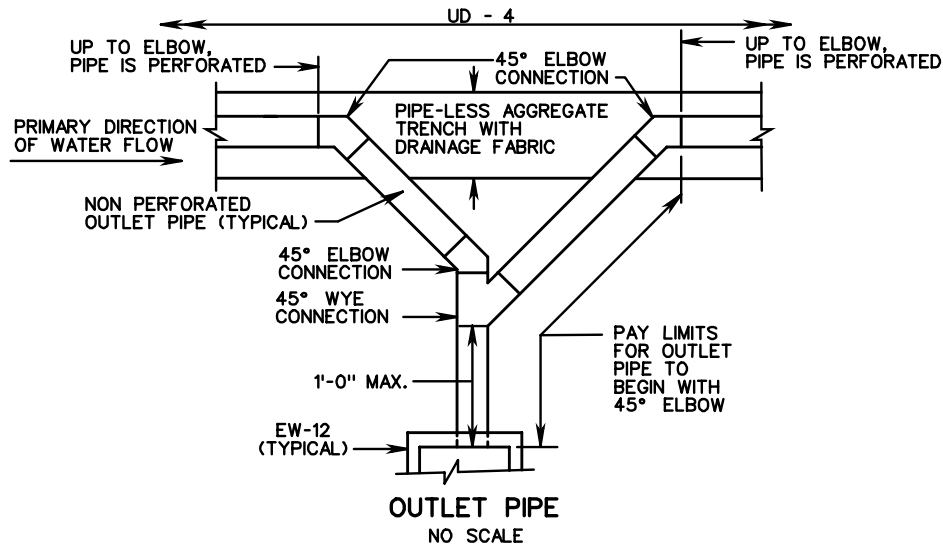
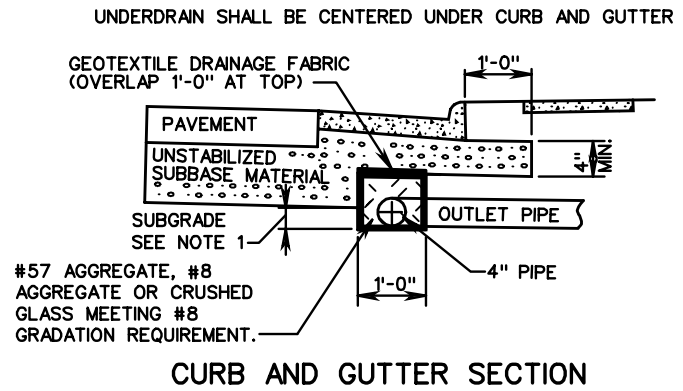
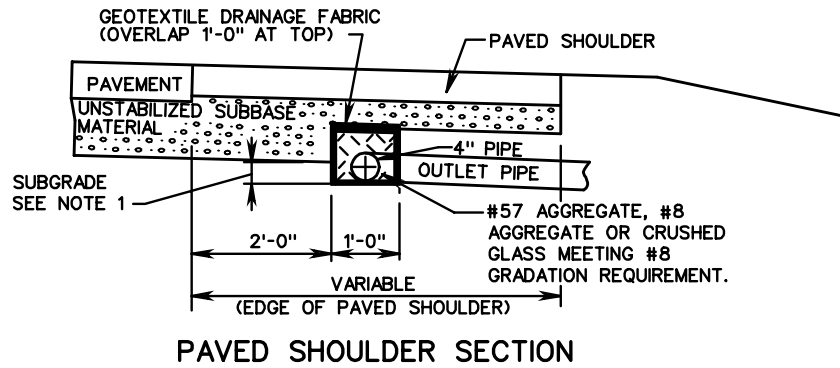

ROAD AND BRIDGE STANDARDS

STANDARD PAVEMENT EDGEDRAIN

SPECIFICATION REFERENCE

SHEET 1 OF 2

REVISION DATE

240
258
501
701

108.06

VIRGINIA DEPARTMENT OF TRANSPORTATION

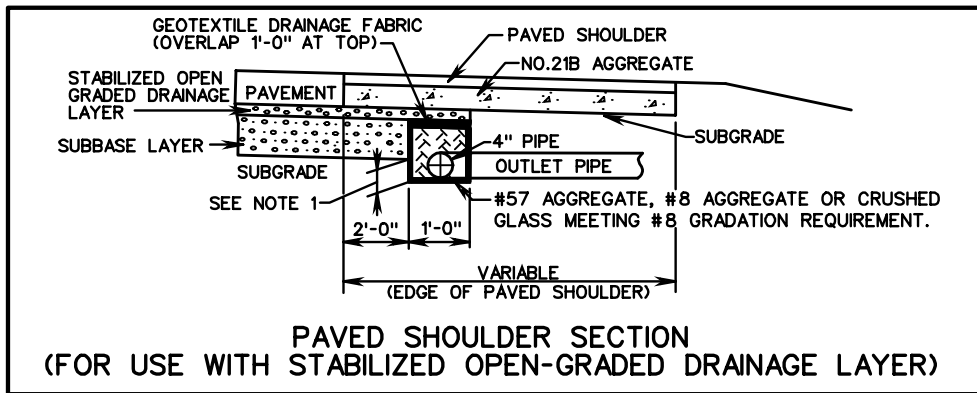

**PAVED SHOULDER SECTION
(FOR USE WITH STABILIZED OPEN-GRADED DRAINAGE LAYER)**

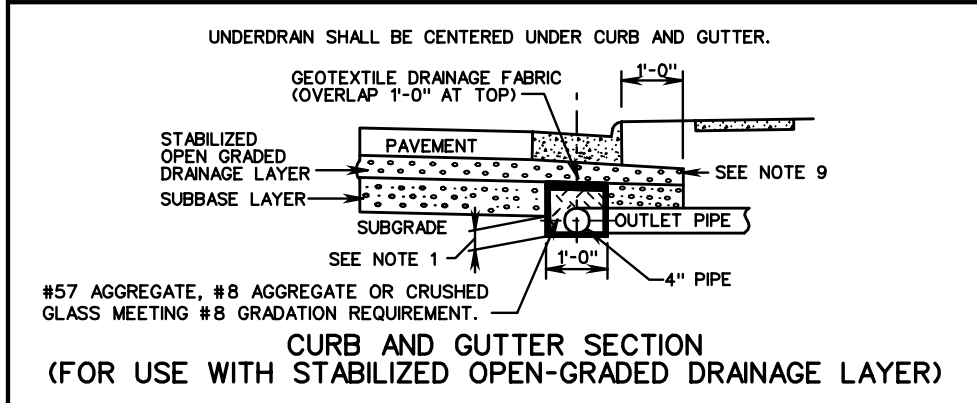

**CURB AND GUTTER SECTION
(FOR USE WITH STABILIZED OPEN-GRADED DRAINAGE LAYER)**

- NOTES:**
1. 4" MINIMUM, PROVIDED ATTAINING MINIMUM 4" OF AGGREGATE ON TOP OF PIPE.
 2. WHEN THE LONGITUDINAL PIPE CONNECTS DIRECTLY INTO A DRAINAGE STRUCTURE (DROP INLET, MANHOLE, ECT.), NON-PERFORATED OUTLET PIPES ARE NOT REQUIRED.
 3. INVERT ELEVATION AT OUTLET END OF OUTLET PIPE TO BE A MINIMUM OF 1'-0" ABOVE INVERT ELEVATION OF RECEIVING DRAINAGE DITCH OR STRUCTURE.
 4. ALL CONNECTIONS (ELBOWS, WYES, ETC.) WITHIN PAY LIMITS FOR OUTLET PIPE ARE TO BE OF THE SAME CRUSHING STRENGTH AS THE OUTLET PIPE.
 5. OUTLET PIPES ARE TO BE INSTALLED ON 2% MIN. (3% DESIRABLE) GRADE AND LOCATED EVERY 350' MAXIMUM OR AS NOTED ON PLANS.
 6. OUTLET PIPE TO BE SECURELY CONNECTED TO EW-12 OR OTHER DRAINAGE STRUCTURE.
 7. WITHIN THE LIMITS OF A COMMERCIAL ENTRANCE, NON-PERFORATED PIPE SHALL BE UTILIZED IN LIEU OF PERFORATED PIPE.
 8. THE LENGTH OF PIPE BETWEEN THE WYE CONNECTION AND THE EW-12 SHALL BE LIMITED TO NO MORE THAN 1'-0" TO PERMIT CAMERA INSPECTION OF THE MAIN LINE IN EITHER DIRECTION.
 9. IN SITUATIONS WHEN FULL DEPTH OF STABILIZED OPEN-GRADED MATERIAL CANNOT BE MAINTAINED UNDER CURB AND GUTTER, NO. 21B AGGREGATE SHALL BE USED UNDER CURB AND GUTTER. NO. 21B AGGREGATE MAY ALSO BE USED FROM TOP OF STABILIZED OPEN-GRADED MATERIAL LAYER AND CURB AND GUTTER.

SPECIFICATION REFERENCE
240
258
501
701

STANDARD PAVEMENT EDGEDRAIN

VIRGINIA DEPARTMENT OF TRANSPORTATION

LONGITUDINAL PERFORATED PIPE

UD-4

TYPE OF PIPE	CRUSHING STRENGTH	
	W.T.	4" NOM. DIAMETER
SMOOTH WALL PVC	.103	
CORRUGATED PE		AASHTO M-252

NON-PERFORATED OUTLET PIPE FOR USE UNDER COMMERCIAL ENTRANCES AND FOR OUTLETS

TYPE OF PIPE	CRUSHING STRENGTH	
	W.T.	4" NOM. DIAMETER
SMOOTH WALL PVC	.103	
SMOOTH WALL PE		70 PSI ***

WALL THICKNESS (MIN) - INCHES
 *** TESTED ACCORDING TO ASTM D-2412 AT 5% DEFLECTION.

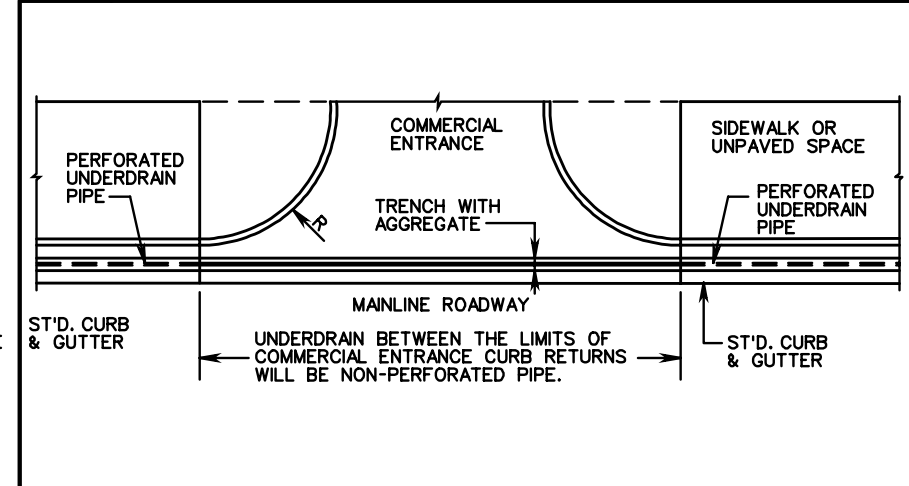
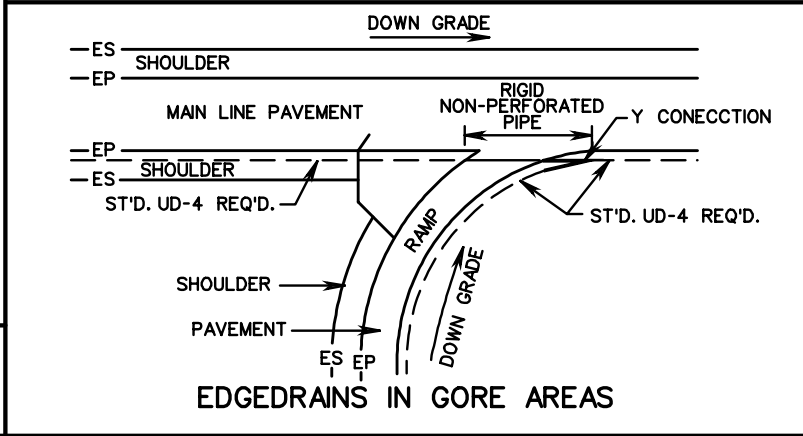

ROAD AND BRIDGE STANDARDS

REVISION DATE	SHEET 2 OF 2
	108.07

UD-5

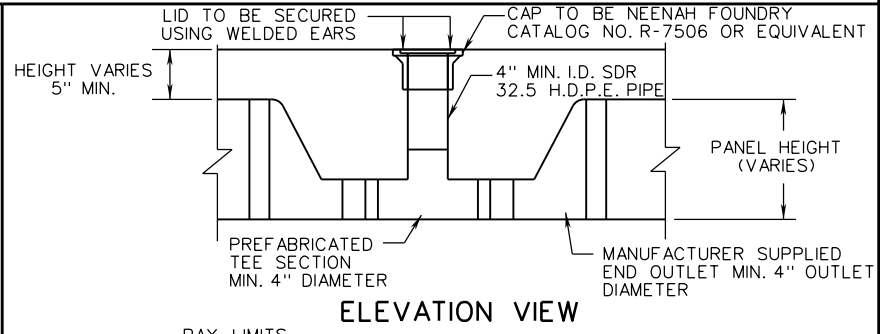
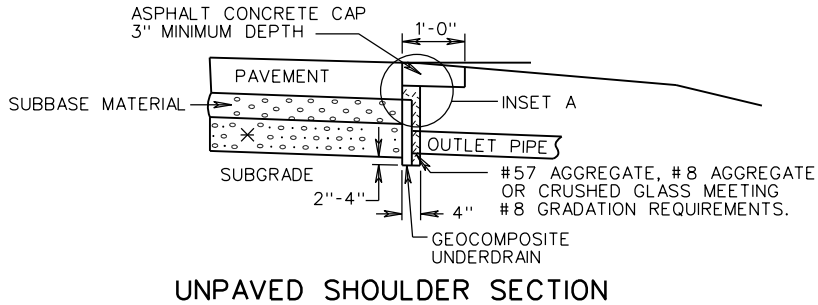
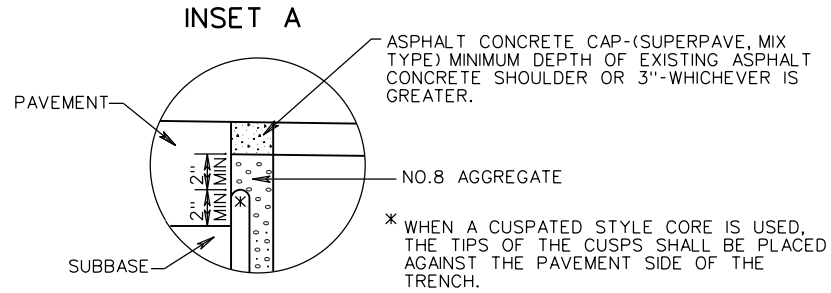
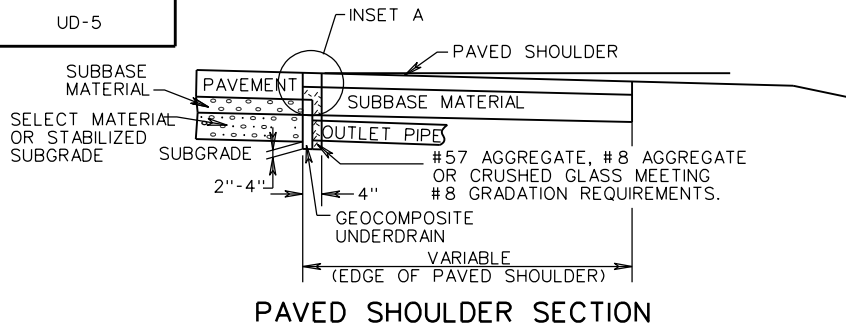

* SELECT MATERIAL OR STABILIZED SUBGRADE MATERIAL

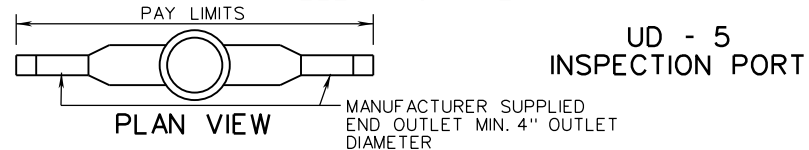

UD - 5 INSPECTION PORT

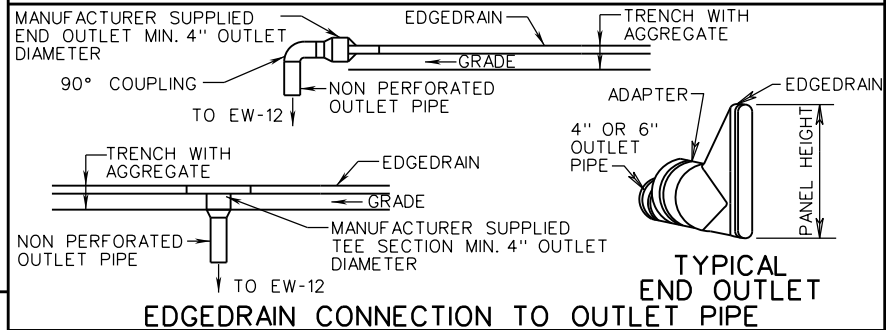
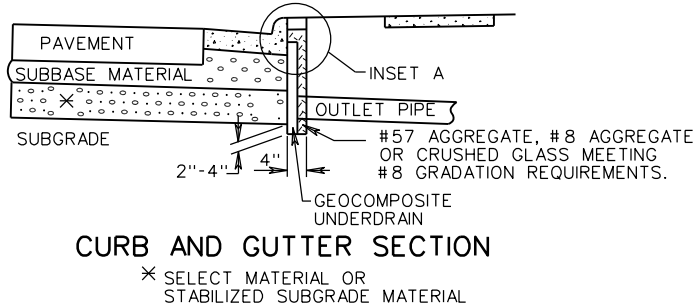

NOTES:

1. INVERT ELEVATION AT OUTLET END OF OUTLET PIPE TO BE A MINIMUM OF 1'-0" ABOVE INVERT ELEVATION OF RECEIVING DRAINAGE DITCH OR STRUCTURE.
2. ALL CONNECTIONS (ELBOWS, WYES, ETC.) WITHIN PAY LIMITS FOR OUTLET PIPE SHALL BE OF THE SAME CRUSHING STRENGTH AS THE OUTLET PIPE.
3. OUTLET PIPES SHALL BE INSTALLED ON 2% MIN. (3% DESIRABLE) GRADE AND LOCATED EVERY 350' MAXIMUM OR AS NOTED ON PLANS.
4. OUTLET PIPE TO BE SECURELY CONNECTED TO EW-12 OR OTHER DRAINAGE STRUCTURE.
5. UD-5 INSPECTION PORTS SHALL BE LOCATED WHERE SPECIFIED ON THE PLANS.

NON-PERFORATED OUTLET PIPE

TYPE OF PIPE	CRUSHING STRENGTH	
	W.T. 4" NOM. DIAMETER	W.T. 6" NOM. DIAMETER
CORRUGATED ALUMINUM	0.048	
SMOOTH WALL PVC	.103	0.153
SMOOTH WALL PE	70 PSI ***	70 PSI ***

* WALL THICKNESS (MIN) - INCHES
 *** TESTED ACCORDING TO ASTM D-2412 AT 5% DEFLECTION.



ROAD AND BRIDGE STANDARDS

SHEET 1 OF 1

REVISION DATE

108.08

01/15

A COPY OF THE ORIGINAL SEALED AND SIGNED DRAWING IS ON FILE IN THE CENTRAL OFFICE.
PREFABRICATED GEOCOMPOSITE RETROFIT PAVEMENT EDGEDRAIN
 VIRGINIA DEPARTMENT OF TRANSPORTATION

SPECIFICATION REFERENCE

240
501
701

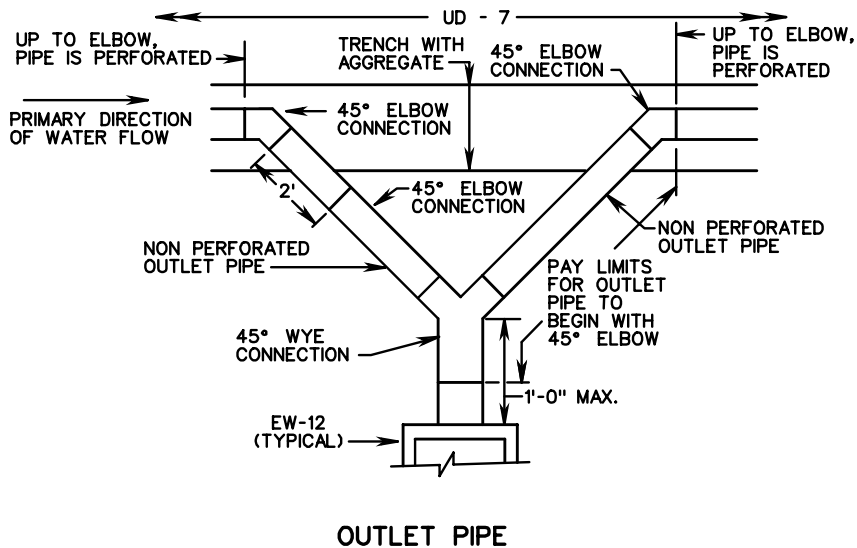
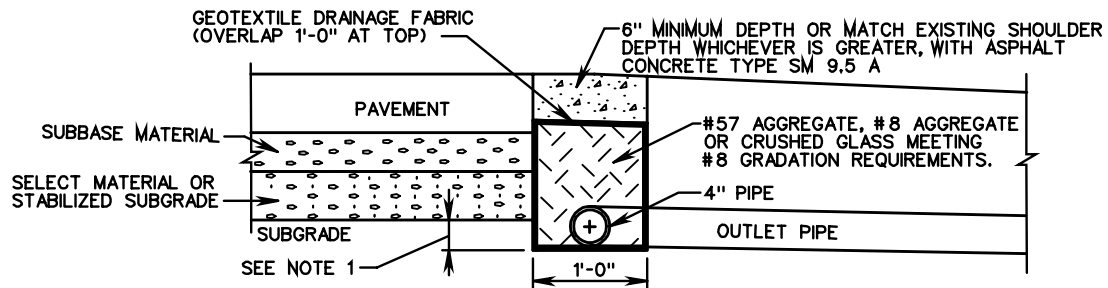

NOTES:

1. 4" MINIMUM, PROVIDED ATTAINING MINIMUM 4" OF AGGREGATE ON TOP OF PIPE.
2. WHERE THE LONGITUDINAL PERFORATED PIPE ALIGNS WITH A DRAINAGE STRUCTURE (DROP INLET, MANHOLE, ETC.), A NON-PERFORATED OUTLET PIPE IS NOT REQUIRED. INSTEAD, THE PERFORATED PIPE IS TO BE CONNECTED DIRECTLY TO THE DRAINAGE STRUCTURE. WHERE THE LONGITUDINAL PERFORATED PIPE IS CONTINUOUS, IT SHALL BE CONNECTED TO EACH SIDE OF THE DRAINAGE STRUCTURE.
3. INVERT ELEVATION AT OUTLET END OF OUTLET PIPE TO BE A MINIMUM OF 1'-0" ABOVE INVERT ELEVATION OF RECEIVING DRAINAGE DITCH OR STRUCTURE.
4. ALL CONNECTIONS (ELBOWS, WYES, ETC.) WITHIN PAY LIMITS FOR OUTLET PIPE ARE TO BE OF THE SAME CRUSHING STRENGTH AS THE OUTLET PIPE.
5. OUTLET PIPES ARE TO BE INSTALLED ON 2% MIN. (3% DESIRABLE) GRADE AND LOCATED EVERY 350' MAXIMUM OR AS NOTED ON PLANS.
6. OUTLET PIPE TO BE SECURELY CONNECTED TO EW-12 OR OTHER DRAINAGE STRUCTURE.
7. WITHIN THE LIMITS OF A COMMERCIAL ENTRANCE, NON-PERFORATED PIPE SHALL BE UTILIZED IN LIEU OF PERFORATED PIPE.
8. THE LENGTH OF PIPE BETWEEN THE WYE CONNECTION AND THE EW-12 SHALL BE LIMITED TO NO MORE THAN 1'-0" TO PERMIT CAMERA INSPECTION OF THE MAIN LINE IN EITHER DIRECTION.
9. EXISTING ASPHALT SHOULDER TO BE SAWED TO ACHIEVE A SMOOTH JOINT.

LONGITUDINAL PERFORATED PIPE

TYPE OF PIPE	CRUSHING STRENGTH	
	× W.T.	4" NOM. DIAMETER
SMOOTH WALL PVC	.103	
CORRUGATED PE		AASHTO M-252

NON-PERFORATED OUTLET PIPE FOR USE UNDER COMMERCIAL ENTRANCES AND FOR OUTLETS

TYPE OF PIPE	CRUSHING STRENGTH	
	× W.T.	4" NOM. DIAMETER
SMOOTH WALL PVC	.103	
SMOOTH WALL PE		70 PSI ×××

× WALL THICKNESS (MIN) - INCHES
 ××× TESTED ACCORDING TO ASTM D-2412 AT 5% DEFLECTION.

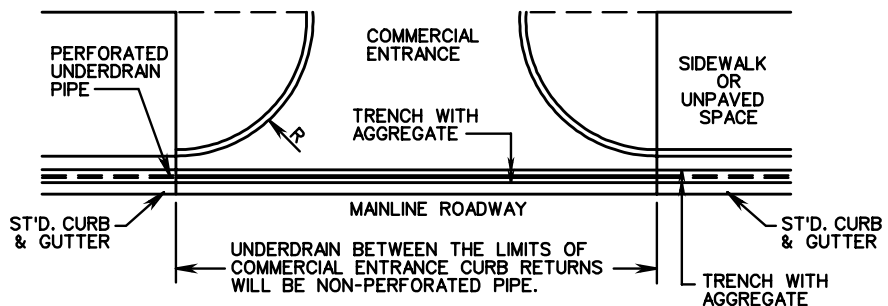

SPECIFICATION REFERENCE
240 501 701

STANDARD RETROFIT EDGEDRAIN

VIRGINIA DEPARTMENT OF TRANSPORTATION

VDOT	
ROAD AND BRIDGE STANDARDS	
REVISION DATE	SHEET 1 OF 1
	108.09

THIS PAGE INTENTIONALLY LEFT BLANK



ROAD AND BRIDGE STANDARDS

SHEET 1 OF 1

REVISION DATE

108.10

VIRGINIA DEPARTMENT OF TRANSPORTATION

SPECIFICATION
REFERENCE

OUTSIDE ROAD DITCHES

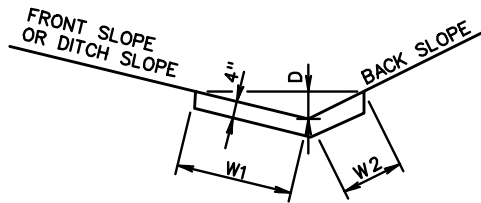

TYPE	D	FRONT SLOPE	BACK SLOPE	W1	W2	K	SQ. YDS. SURFACE AREA/LIN. FT.
A1	6"	6:1	4:1	3'-0"	2'-1"	48	0.565
A1	8"	6:1	4:1	4'-1"	2'-9"	104	0.759
A2	6"	6:1	3:1	3'-0"	1'-7"	42	0.509
A2	8"	6:1	3:1	4'-1"	2'-1"	92	0.685
A3	6"	6:1	2:1	3'-0"	1'-2"	38	0.463
A3	8"	6:1	2:1	4'-1"	1'-6"	82	0.620
B1	6"	4:1	4:1	2'-1"	2'-1"	38	0.463
B1	8"	4:1	4:1	2'-9"	2'-9"	82	0.611
B2	8"	4:1	3:1	2'-9"	2'-1"	72	0.537
B2	10"	4:1	3:1	3'-5"	2'-8"	130	0.676
B3	8"	4:1	2:1	2'-9"	1'-6"	60	0.472
B3	10"	4:1	2:1	3'-5"	1'-10"	111	0.583
B4	8"	4:1	1/2:1	2'-9"	1'-2"	55	0.435
B4	10"	4:1	1/2:1	3'-5"	1'-6"	101	0.546
C1	8"	3:1	2:1	2'-1"	1'-6"	50	0.398
C1	10"	3:1	2:1	2'-8"	1'-10"	92	0.500
C2	10"	3:1	1/2:1	2'-8"	1'-6"	80	0.463
C3	10"	3:1	1:1	2'-8"	1'-2"	70	0.426

MEDIAN DITCH

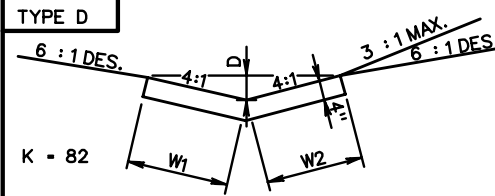

D - DEPTH	W ₁	W ₂	SQ. YDS. SURFACE AREA PER LIN. FT.
8"	2'-9"	2'-9"	0.611

DITCH AT TOE OF FILL OR TOP OF CUT

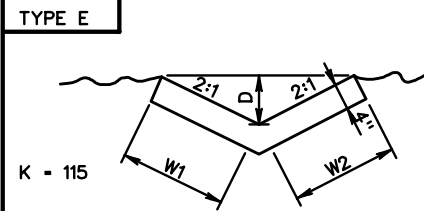

12"	2'-3"	2'-3"	0.500
-----	-------	-------	-------

CURTAIN WALL DETAIL

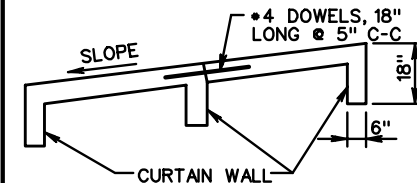

CURTAIN WALL TO BE LOCATED AT BEGINNING AN END OF ALL CHANNELS AND ON THE LOWER END OF EACH EXPANSION JOINT.

PLAN FOR TRANSITION OF PAVED MEDIAN DITCH TO MEDIAN DROP INLET GUTTER

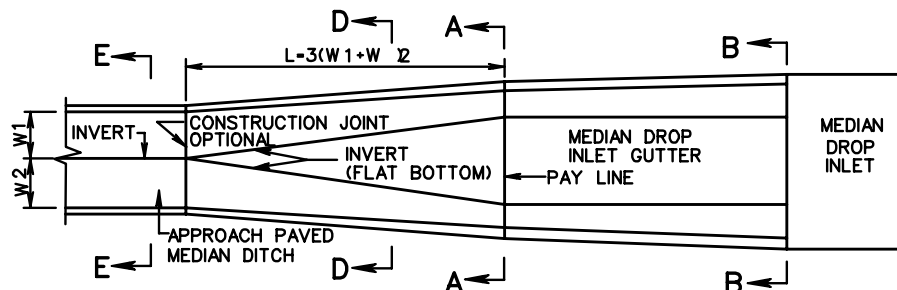

NOTES:
 FOR SECTION A-A AND B-B SEE STANDARDS DI-7, 7A AND 7B.
 TRADITIONAL PORTION OF PAVED DITCH TO BE PAID FOR AT THE SAME PRICE BID PER SQ. YARD FOR APPROACH PAVED MEDIAN DITCH.
 STANDARD PG-2A DITCHES TO BE CLASS A3 CONCRETE.

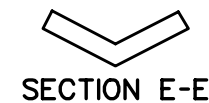
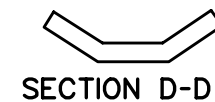

ALTERNATE METHOD OF FORMING DITCHES

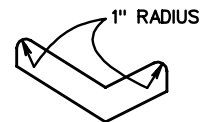

NOTE:
 ALL DITCHES MAY BE CONSTRUCTED WITH VERTICAL SIDES AT THE OPTION OF THE CONTRACTOR.

SPECIFICATION REFERENCE

502

STANDARD PAVED DITCHES

VIRGINIA DEPARTMENT OF TRANSPORTATION

VDOT

ROAD AND BRIDGE STANDARDS

REVISION DATE

SHEET 1 OF 1

109.01

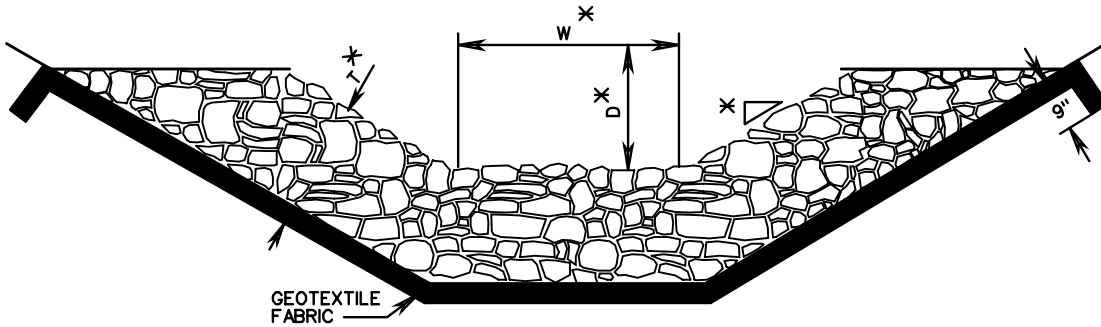

TYPE I
RIPRAP DITCH PROTECTION

MINIMUM THICKNESS "T"	
RIP RAP CLASS	MINIMUM "T"
CLASS AI	20"
CLASS I	26"
CLASS II	38"
CLASS III	53"

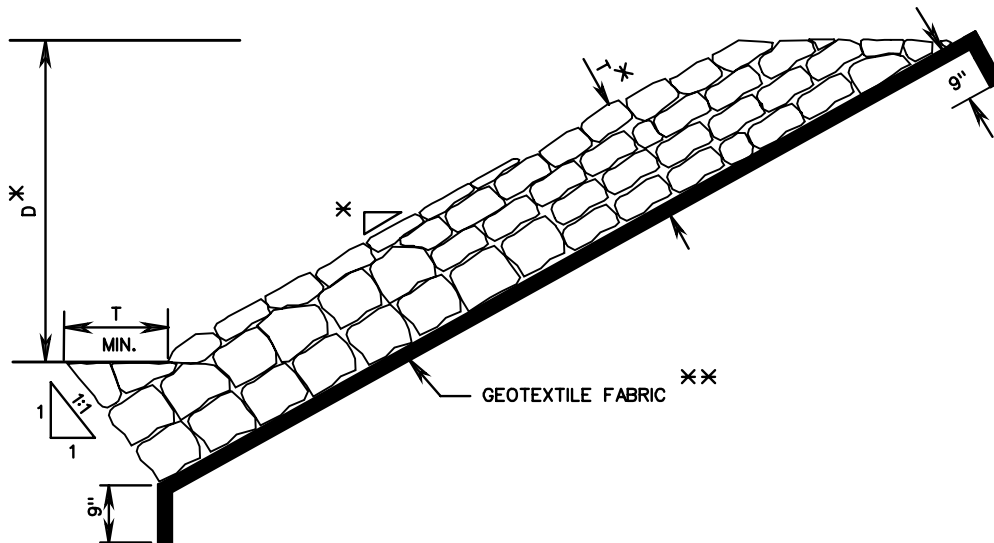

TYPE II
RIPRAP SLOPE PROTECTION

NOTES:

- ×× RIP RAP BEDDING MATERIAL
- GEOTEXTILE FABRIC TO BE PROVIDED UNDER ALL RIPRAP INSTALLATIONS CLASS AI, CLASS I AND CLASS II UNLESS OTHERWISE NOTED ON THE PLANS OR DIRECTED BY THE ENGINEER.
- RIPRAP INSTALLATIONS OF CLASS III SHALL HAVE AN INTERMEDIATE AGGREGATE BEDDING LAYER(S) AS SPECIFIED ON THE PLANS BASED ON GEOTECHNICAL RECOMMENDATIONS.
- × SEE TYPICAL SECTION SHOWN ON PLANS FOR SIDE SLOPE, BOTTOM WIDTH AND DEPTH OF CHANNEL AND RIPRAP THICKNESS.



ROAD AND BRIDGE STANDARDS

STANDARD RIP RAP DITCH & SLOPE PROTECTION
PG-3

SPECIFICATION
REFERENCE

SHEET 1 OF 1

REVISION DATE

109.02

VIRGINIA DEPARTMENT OF TRANSPORTATION

245
414

SCHEDULE OF REINFORCING STEEL

MARK	NO.	LENGTH		SIZE	SPACING C-C	SHAPE
		2:1	1/2:1			
F	3	1'-2"	1'-2"	4	4"	STRAIGHT
G	9	1'-5"	1'-5"	4	6"	STRAIGHT
DOWELS	10	1'-6"	1'-6"	4	5"	STRAIGHT

NO. SHOWN ARE FOR ONE ANCHOR LUG, CURTAIN WALL AND JOINT.

APPROXIMATE QUANTITIES

		CLASS A3 CONCRETE	REINFORCING STEEL
		CU. YDS.	LBS.
ANCHOR LUG	2:1	0.0208	2.34
	1/2:1	0.0216	2.34
CURTAIN WALL	2:1	0.099	8.51
	1/2:1	0.100	8.51
JOINT	2:1	—	10.02
	1/2:1	—	10.02

0.425 SQUARE YARDS SURFACE AREA PER LINEAR FOOT OF FLUME.

NOTE:
DOWELS TO BE LOCATED AT ALL REQUIRED JOINTS.
K VALUE = 128

FOR DETAILS OF PIPE SPILLOUTS FOR 12"-24" CULVERTS, SEE STANDARD DRAWINGS PS-2 AND PS-3.

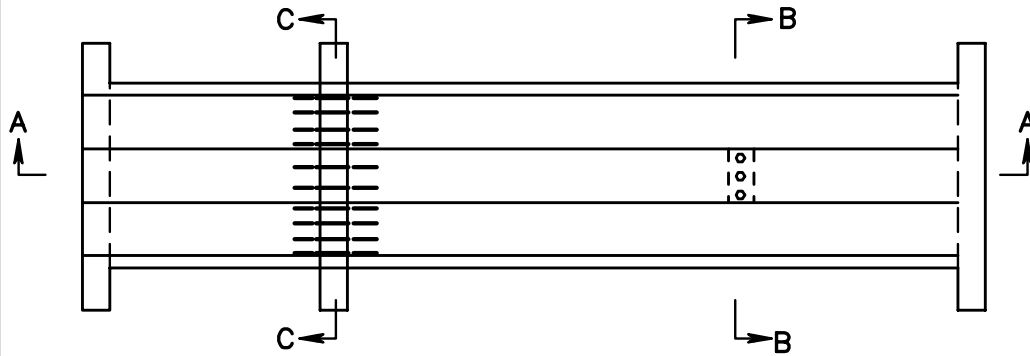

PLAN VIEW

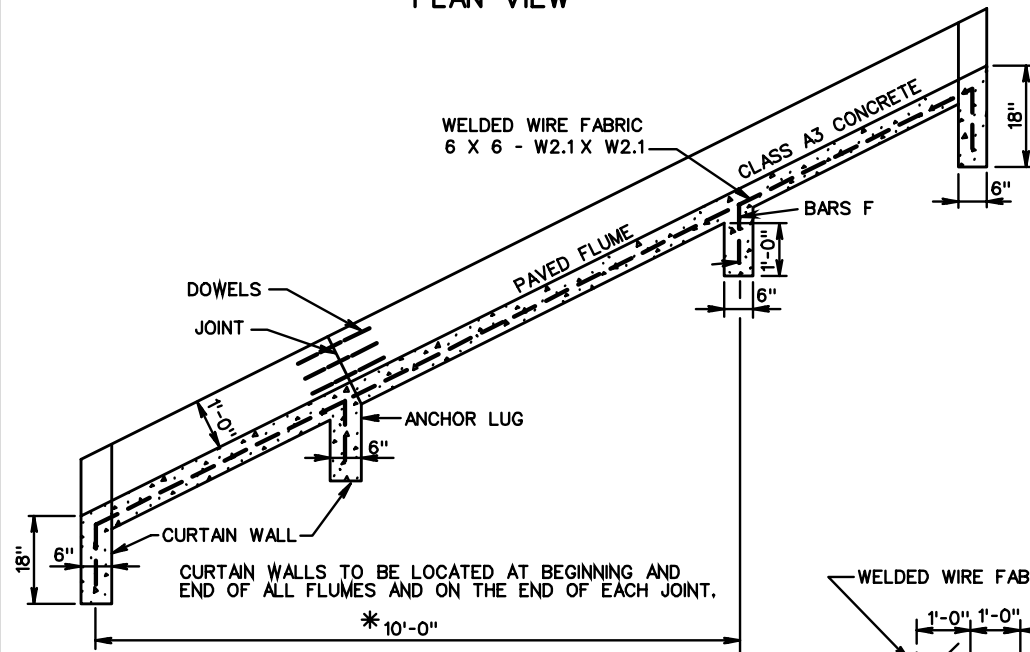

SECTION A-A

*10'-0" C-C MAXIMUM TYPICAL SPACING BETWEEN ANCHOR LUGS. ANCHOR LUG IS TO BE A MAXIMUM OF 2' FROM END OF CHANNEL.

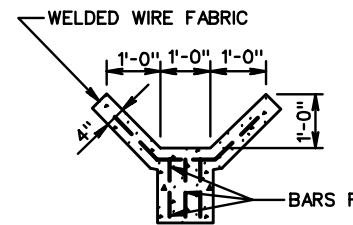

SECTION B-B

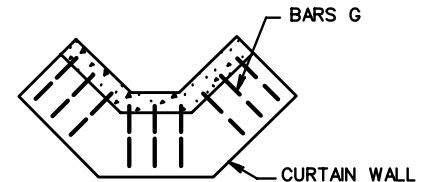

SECTION C-C

SPECIFICATION REFERENCE

502

STANDARD PAVED FLUME FOR 12" - 24" PIPE

VIRGINIA DEPARTMENT OF TRANSPORTATION

VDOT

ROAD AND BRIDGE STANDARDS

REVISION DATE

SHEET 1 OF 1

109.03

 INDICATES CHANNEL WHERE WIRE MESH REINFORCEMENT IS NOT REQUIRED.

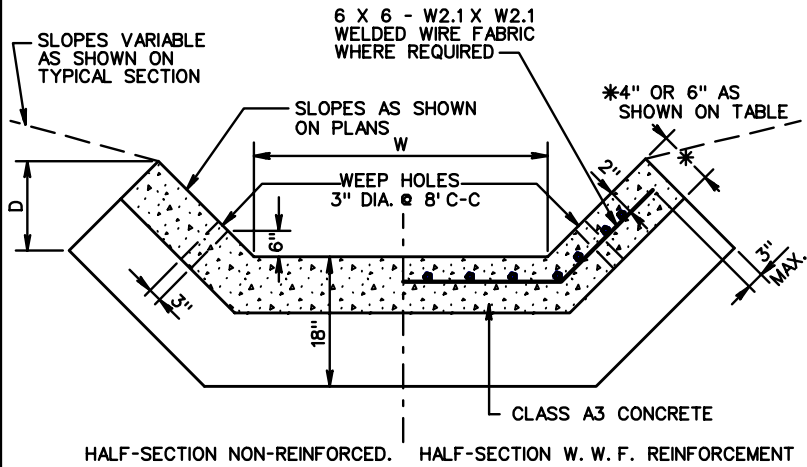

SECTION A-A

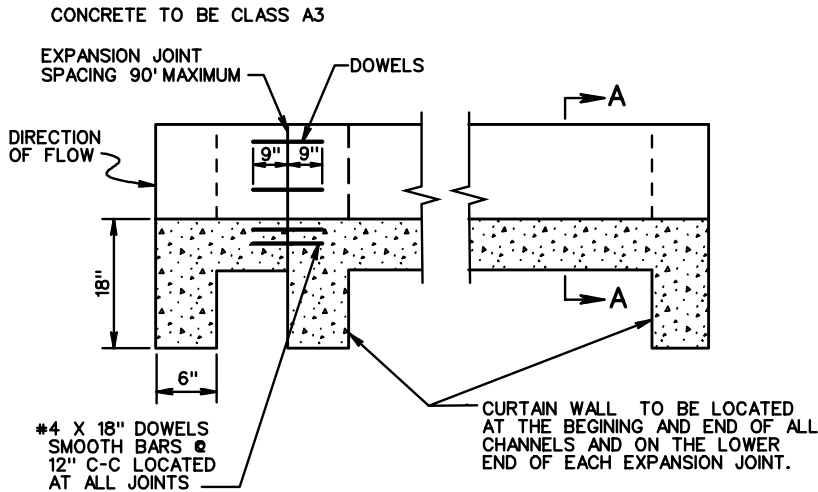

ELEVATION

SQUARE YARDS PER LIN. FT. OF PAVED CHANNEL

CONC. THICKNESS	D	W									
		1'	2'	3'	4'	5'	6'	7'	8'	9'	10'
1:1 SIDE SLOPES											
4"	1'	0.425	0.536	0.648	0.759	0.870	0.981	1.092	1.203	1.314	1.425
	2'	0.740	0.851	0.962	1.073	1.184	1.295	1.406	1.517	1.629	1.740
	3'	1.054	1.165	1.276	1.387	1.498	1.609	1.721	1.832	1.943	2.054
	4'	1.368	1.479	1.590	1.702	1.813	1.924	2.035	2.146	2.257	2.368
6"	5'	1.682	1.794	1.905	2.016	2.127	2.238	2.349	2.460	2.571	2.682
	6'	1.997	2.108	2.219	2.330	2.441	2.552	2.663	2.774	2.886	2.997
	7'	2.311	2.422	2.533	2.644	2.755	2.866	2.977	3.089	3.200	3.311
	8'	2.625	2.736	2.848	2.959	3.070	3.181	3.292	3.403	3.514	3.625
	9'	2.940	3.051	3.162	3.273	3.384	3.495	3.606	3.717	3.828	3.939
	10'	3.254	3.365	3.476	3.587	3.698	3.809	3.920	4.032	4.143	4.254
1.5:1 SIDE SLOPES											
4"	1'	0.512	0.623	0.734	0.845	0.956	1.067	1.178	1.290	1.401	1.512
	2'	0.912	1.023	1.135	1.246	1.357	1.468	1.579	1.690	1.801	1.912
	3'	1.313	1.424	1.535	1.646	1.757	1.869	1.980	2.091	2.202	2.313
	4'	1.714	1.825	1.936	2.047	2.158	2.269	2.380	2.491	2.602	2.714
6"	5'	2.114	2.225	2.336	2.448	2.559	2.670	2.781	2.892	3.003	3.114
	6'	2.515	2.626	2.737	2.848	2.959	3.070	3.181	3.293	3.404	3.515
	7'	2.915	3.027	3.138	3.249	3.360	3.471	3.582	3.693	3.804	3.915
	8'	3.316	3.427	3.538	3.649	3.760	3.872	3.983	4.094	4.205	4.316
	9'	3.717	3.828	3.939	4.050	4.161	4.272	4.383	4.494	4.606	4.717
	10'	4.117	4.228	4.340	4.451	4.562	4.673	4.784	4.895	5.006	5.117
2:1 SIDE SLOPES											
4"	1'	0.608	0.719	0.830	0.941	1.052	1.164	1.275	1.386	1.497	1.608
	2'	1.105	1.216	1.327	1.438	1.549	1.660	1.772	1.883	1.994	2.105
	3'	1.602	1.713	1.824	1.935	2.046	2.157	2.268	2.380	2.491	2.602
	4'	2.099	2.210	2.321	2.432	2.543	2.654	2.765	2.876	2.988	3.099
6"	5'	2.596	2.707	2.818	2.929	3.040	3.151	3.262	3.373	3.485	3.596
	6'	3.093	3.204	3.315	3.426	3.537	3.648	3.759	3.870	3.981	4.093
	7'	3.589	3.701	3.812	3.923	4.034	4.145	4.256	4.367	4.478	4.589
	8'	4.086	4.197	4.309	4.420	4.531	4.642	4.753	4.864	4.975	5.086
	9'	4.583	4.694	4.805	4.917	5.028	5.139	5.250	5.361	5.472	5.583
	10'	5.080	5.191	5.302	5.413	5.525	5.636	5.747	5.858	5.969	6.080

NOTES:

DEPTH (D) AND WIDTH (W) TO BE AS SHOWN ON PLANS.
 WEEP HOLES ARE TO BE PROVIDED ON ALL CHANNELS WHERE W IS EQUAL TO OR GREATER THAN 4' AND D IS EQUAL TO OR GREATER THAN 2'.
 WEEP HOLE WITH 12" X 12" PLASTIC HARDWARE CLOTH, 1/4" MESH OR GALVANIZED STEEL WIRE DIAMETER 0.03 INCH, NUMBER 4 MESH, HARDWARE CLOTH ANCHORED FIRMLY TO THE BOTTOM OF THE CHANNEL.



ROAD AND BRIDGE STANDARDS

SHEET 1 OF 1

REVISION DATE

109.04

STANDARD PAVED DITCHES

VIRGINIA DEPARTMENT OF TRANSPORTATION

SPECIFICATION REFERENCE

502

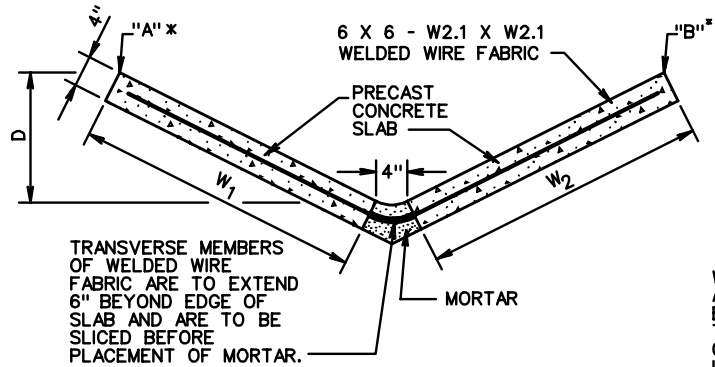

W1	W2	D	K
3'-0"	2'-0"	10"	112
3'-0"	2'-0"	12"	145
3'-0"	3'-0"	10"	137
3'-0"	3'-0"	12"	181
2'-0"	2'-0"	10"	87
2'-0"	2'-0"	12"	111
3'-0"	2'-0"	8"	80
3'-0"	3'-0"	8"	96
2'-0"	2'-0"	8"	64

WIDTH OF SLABS (W) IS TO BE 2'-0" OR 3'-0". ANY COMBINATION OF THESE WIDTHS MAY BE USED DEPENDING ON REQUIREMENTS. THE SLAB LENGTH IS TO BE AT THE OPTION OF THE FABRICATOR BUT IS NOT TO EXCEED LIMITS THAT WOULD FACILITATE EASY HANDLING.

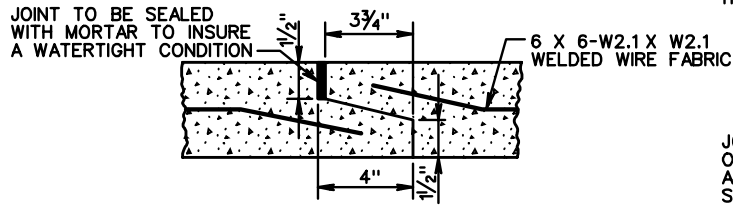

JOINT DETAIL SHOWN IS SUGGESTED ONLY. OTHER FABRICATOR'S DESIGN MEETING THE APPROVAL OF THE ENGINEER MAY BE SUBSTITUTED.

PRECAST CONCRETE VEE DITCH

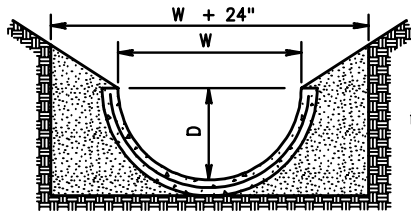

1/2 ROUND SECTION FOR USE ON SLOPES AND FOR FLUMES ONLY.

PIPE SIZE	D	W	K SMOOTH	K C.M.
12"	6"	1'-0"	15	10
15"	7 1/2"	1'-3"	28	17
18"	9"	1'-6"	46	28
21"	10 1/2"	1'-9"	69	43

TRENCH IS TO BE EXCAVATED, PIPE SECTIONS PLACED, AND TRENCH REFILLED. THE MATERIAL PLACED AROUND THE PIPE IS TO BE FREE OF ROCK AND IS TO BE FIRMLY TAMPED.

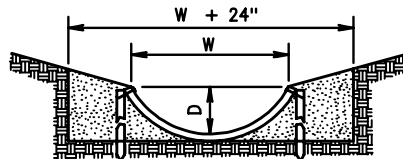

1/3 ROUND SECTION

PIPE SIZE	D	W	K SMOOTH	K C.M.
24"	6"	1'-8 5/8"	27	17
30"	7 1/2"	2'-2"	49	31
36"	9"	2'-7 3/8"	79	49
42"	10 1/2"	3'-3 3/8"	118	74
48"	1'-0"	3'-5 5/8"	173	108
54"	1'-1 1/2"	3'-10 3/4"	234	146
60"	1'-3"	4'-3 5/8"	309	193

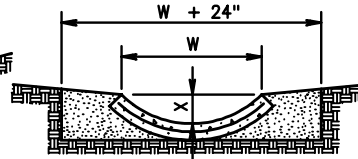

1/4 ROUND SECTION

PIPE SIZE	D	W	K SMOOTH	K C.M.
54"	7 1/8"	3'-2 1/4"	83	52
60"	8 3/4"	3'-6 1/2"	109	68
66"	9 5/8"	3'-10 3/4"	142	88
72"	10 1/2"	4'-3"	179	112
78"	11 3/8"	4'-7 1/4"	235	147
84"	1'-0 1/4"	4'-11 1/2"	269	168
90"	1'-1 1/8"	5'-5 3/4"	325	203

PIPE DRAIN DITCH LINER

CONCRETE VEE DITCH

ALL CONCRETE TO BE 4000 PSI. LIFTING DEVICES OF THE FABRICATOR'S DESIGN ARE TO BE FURNISHED WHEN REQUIRED.

BASIS OF PAYMENT TO BE SQUARE YARDS OF SURFACE MEASURE WHICH IS TO INCLUDE FURNISHING AND PLACING CONCRETE SLABS AND MORTARING JOINTS.

PIPE DRAIN DITCH LINER

PIPE SECTIONS MAY BE USED IN ROADSIDE DITCHES, MEDIAN DITCHES, SLOPE DRAINS, AND FLUMES WITH THE EXCEPTION OF 1/2 ROUND SECTIONS WHICH ARE RESTRICTED TO SLOPE DRAINS AND FLUMES ONLY.

WHEN PIPE DRAIN DITCH LINER IS SUBSTITUTED FOR STANDARD PG-2A OR 4 SPECIFIED ON THE PLANS, THE CONTRACTOR MUST SELECT A "K" VALUE SHOWN HEREON THAT IS EQUAL TO OR GREATER THAN THE "K" VALUE FOR THE TYPE AT STANDARD PAVED DITCH SHOWN BELOW.

"K" IS THE CONVEYANCE FACTOR AS CALCULATED BY THE MANNING'S FORMULA FOR FLOW IN OPEN CHANNELS.

PIPE DRAIN DITCH LINERS ARE TO BE CONSTRUCTED FROM SECTIONS OF CONCRETE PIPE OR REGULAR REINFORCED CONCRETE PIPE, BITUMINIZED FIBER PIPE, CORRUGATED ALUMINUM PIPE, OR CORRUGATED STEEL PIPE. NON-REINFORCED SECTIONS MAY BE USED FOR CONCRETE PIPE SIZES 24" OR LESS.

JOINTS TO BE OF STANDARD MANUFACTURER'S DESIGN FOR REGULAR CONCRETE PIPE AND MAY BE LAPPED, BUTTED WITH A COLLAR, OR BELL AND SPIGOT FOR BITUMINIZED FIBER PIPE. JOINTS FOR CORRUGATED METAL PIPE MAY BE BOLTED OR RIVETED. ALL JOINTS TO BE SEALED TO INSURE A WATER TIGHT BOND.

BITUMINIZED FIBER AND CORRUGATED METAL PIPE TO BE ANCHORED WITH 1" X 4" X 30" PRESSURE PRESERVATIVE TREATED STAKES PLACED AT ALL JOINTS WITH INTERMEDIATE SPACING NOT TO EXCEED 10 FEET. #4 X 30" HOOKED DEFORMED BARS MAY BE SUBSTITUTED IF APPROVED BY THE ENGINEER.

CONCRETE AND CORRUGATED METAL PIPE SECTIONS ARE TO BE AS SPECIFIED IN STANDARD PC-1 AND SPECIFICATIONS FOR MINIMUM HEIGHT OF FILL. BITUMINOUS FIBER PIPE SHALL CONFORM TO SECTION 240 OF THE SPECIFICATIONS, AND IS LIMITED TO SIZES 24" OR LESS.

INLET END OF PIPE DRAIN DITCH LINER INSTALLATION IS TO BE PROTECTED WITH ASPHALT OR CONCRETE TREATMENT AS DIRECTED BY THE ENGINEER TO PREVENT UNDERCUTTING.

COST OF PROTECTION TO BE INCLUDED IN PRICE BID FOR LINEAR FEET OF PIPE DRAIN DITCH LINER.

AT THE OPTION OF THE FABRICATOR, CONCRETE PIPE MAY BE GROOVED FOR SPLITTING.

LIFTING DEVICES OF FABRICATOR'S DESIGN ARE TO BE FURNISHED WHEN REQUIRED.

PIPE SECTIONS ARE TO BE AS SPECIFIED IN PIPE STANDARD PC-1 FOR MINIMUM HEIGHT OF FILL.

SPECIFICATION REFERENCE

232
502

STANDARD PRECAST PAVED DITCHES
(CONCRETE, CORRUGATED METAL & BITUMINOUS FIBER PIPES)

VIRGINIA DEPARTMENT OF TRANSPORTATION



ROAD AND BRIDGE STANDARDS

REVISION DATE

SHEET 1 OF 1

109.05

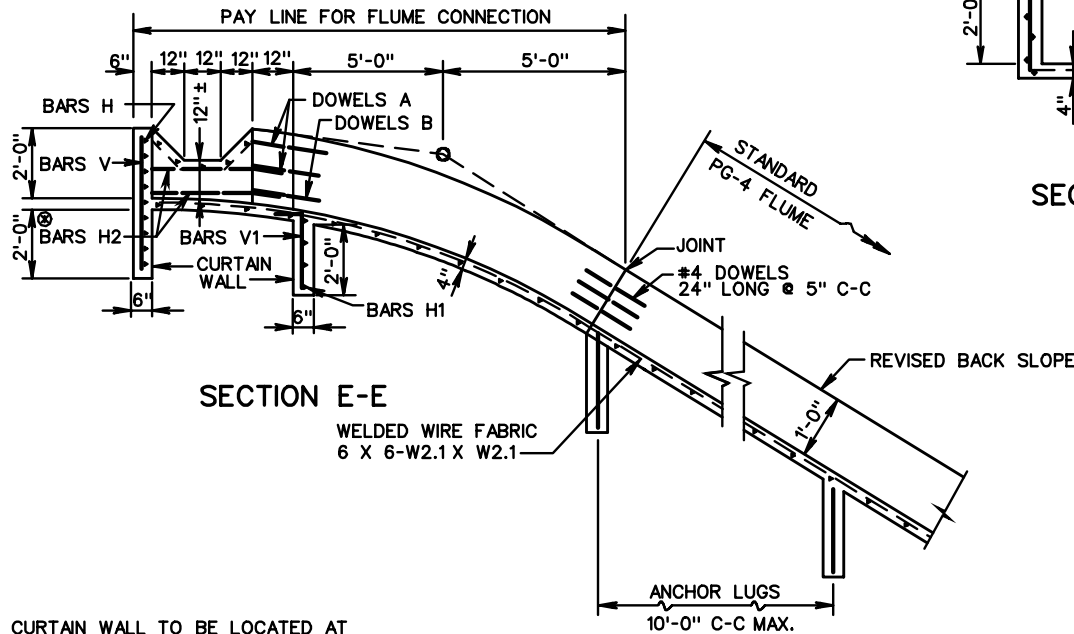
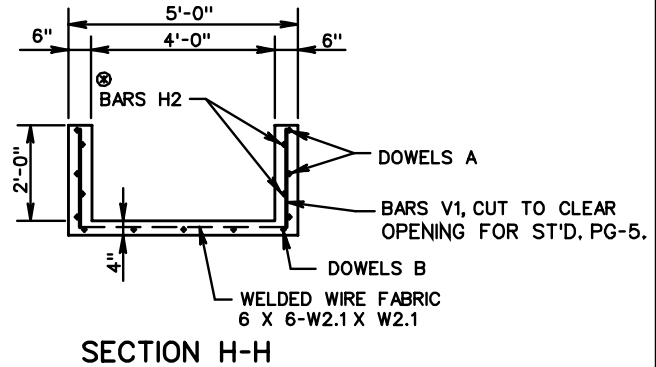
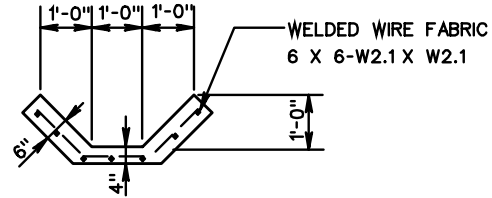
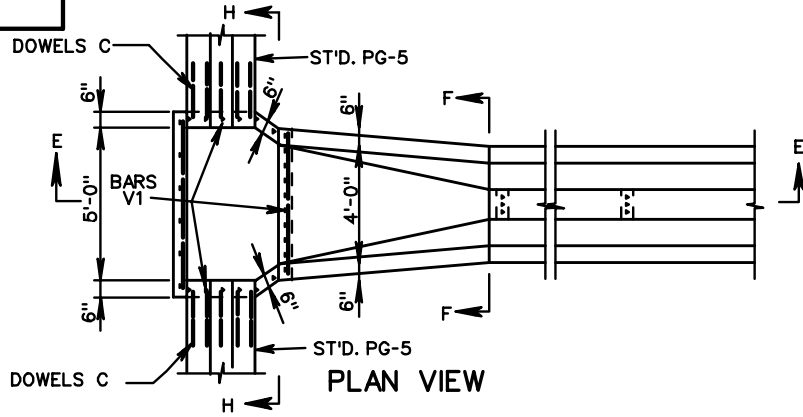

REINFORCING STEEL SCHEDULE				
MARK	SIZE	NO.	SPACING	LENGTH
H	#3	9	6"	5'-8"
H1	#3	4	6"	4'-8"
H2	#3	6	6"	5'-3"
V	#4	6	12"	4'-0"
V1	#4	24	6"	3'-0"
DOWELS A	#4	12	10"	2'-0"
DOWELS B	#4	6	10"	2'-0"
DOWELS C	#4	10	10"	1'-0"
W.W.F.	8GA			83 S.F.

BENDING DIAGRAM	
<p>BARS V1</p>	<p>DOWELS A SECTIONS H-H</p>
<p>BARS H2</p>	

CURTAIN WALL TO BE LOCATED AT BEGINNING AND END OF ALL FLUMES AND ON THE LOWER END OF EACH JOINT.

PRICE BID PER EACH TO INCLUDE DOWELS, WELDED WIRE FABRIC, REINFORCING STEEL, ANCHOR LUGS AND CURTAIN WALL, AND CLASS A-3 CONC.

⊗ FIELD CUT BARS V1 & BARS H2 TO CLEAR OPENING FOR ST'D. PG-5.

APPROXIMATE QUANTITIES	
REINFORCING STEEL 132.9 LBS.	CLASS A3 CONC. 1.7 CU. YDS.



ROAD AND BRIDGE STANDARDS

SHEET 1 OF 1

REVISION DATE

109.06

DITCH FLUME CONNECTOR

VIRGINIA DEPARTMENT OF TRANSPORTATION

SPECIFICATION REFERENCE

502

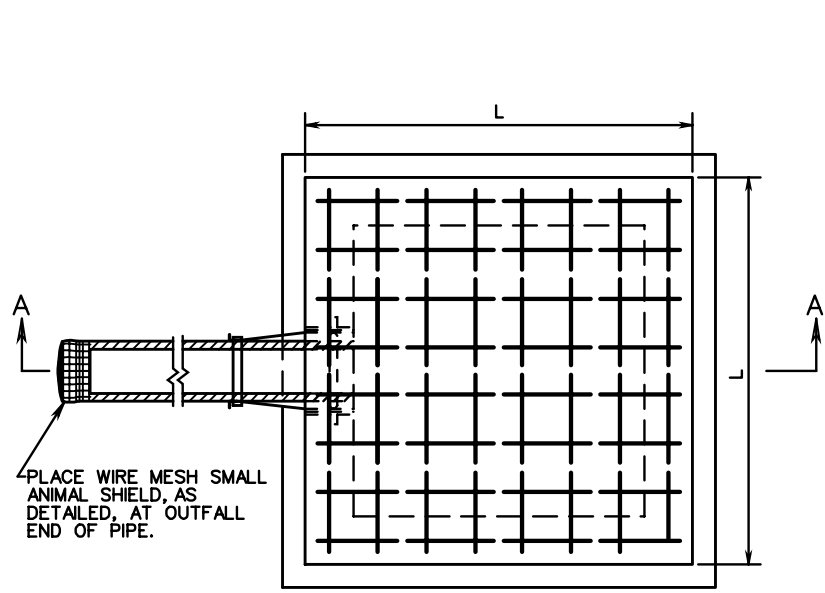

PLAN

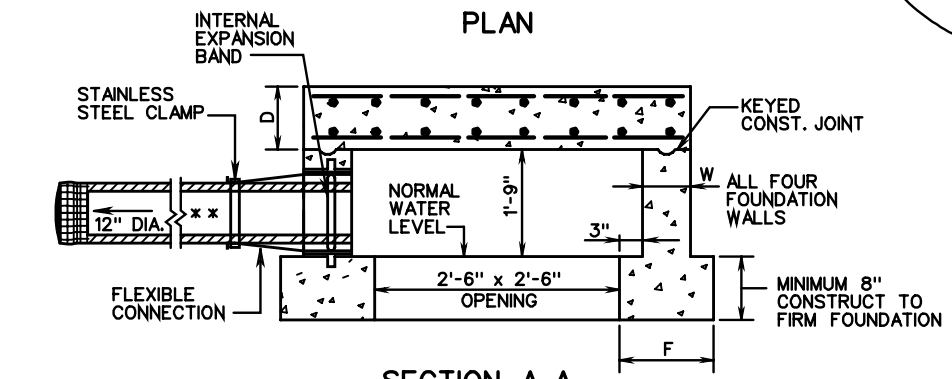

SECTION A-A

** STANDARD RECOMMENDED PIPE IS 12" DUCTILE IRON WATER LINE, PUSH ON JOINTS, CLASS TO BE SPECIFIED BASED UPON HEIGHT OF COVER.

3/4" X 3/4" MESH, HARDWARE CLOTH MIN. 17 GAUGE, GALVANIZED AFTER WEAVING.

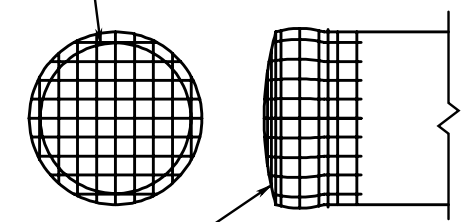

CRIMP AROUND OUTLET END OF PIPE AND SECURE TO PIPE WITH GALVANIZED STEEL WIRE

ANIMAL SHIELD DETAIL

NOTES:
ALL CONCRETE TO BE CLASS A3 IF CAST IN PLACE. FOR PRECAST SEE SHEET 110.02.

CONCRETE QUANTITIES SHOWN ARE BASED ON A 12" DUCTILE IRON WATER LINE. IF OTHER SIZE OR TYPE OF PIPE IS USED QUANTITIES ARE TO BE ADJUSTED ACCORDINGLY.

COST OF WIRE MESH SHIELD AT OUTFALL END OF PIPE IS TO BE INCLUDED IN PRICE BID FOR PIPE.

THIS ITEM MAY BE PRECAST OR CAST IN PLACE.

CONTRACTOR IS TO PROVIDE OPENING FOR PIPE AND FLEXIBLE CONNECTOR BY CORING OR CAST-IN-PLACE SLEEVE WITH WATER STOP COLLAR.

PIPE(S) SHALL BE CONNECTED TO SPRING BOX WITH A FLEXIBLE BOOT MEETING ASTM SPECIFICATION C-923. COST OF FLEXIBLE CONNECTION TO BE INCLUDED IN BID PRICE FOR SPRING BOX. BOOT SHALL BE MADE FROM NEOPRENE RUBBER AND HAVE A 3/8" MINIMUM WALL THICKNESS THROUGHOUT. THE INTERNAL EXPANSION BAND TO SECURE THE BOOT IN PLACE SHALL CONFORM TO ALUMINUM MATERIAL SPECIFICATION 6061-T6. THE EXTERNAL BAND TO CLAMP AND SEAL THE BOOT TO THE PIPE SHALL BE STAINLESS STEEL-CORROSION RESISTANT CONFORMING TO ASTM SPECIFICATION A-167. THE OPENING TO RECEIVE THE FLEXIBLE CONNECTION SHALL BE CORE DRILLED AND IS TO BE CONSTRUCTED TO ALLOW FOR LATERAL AND VERTICAL MOVEMENT, AS WELL AS ANGULAR ADJUSTMENT THRU 20 DEGREES. ALL FIELD INSTALLATION OF PIPE TO SPRING BOX USING FLEXIBLE BOOT SHALL BE COMPLETED IN ACCORDANCE WITH THE MANUFACTURER'S RECOMMENDATIONS AND SPECIFICATIONS.

HEIGHT OF FILL	SIZE (L)	TOP SLAB (D)	SIDEWALLS (W)	FOOTING WIDTH (F)	REINFORCING STEEL				QUANTITIES		
					NO. REQ'D.	LENGTH	SIZE	SPACING C-C	CU. YDS. CONC.	REINF. STEEL LBS.	INCREMENT * CU. YDS.
BELOW 25'	4'	8"	6"	12"	32	3'-9"	#4	6"	1.189	80	0.043
25' - 50'	4'-4"	8"	8"	14"	32	4'-1"	#5	6"	1.512	136	0.053

* QUANTITIES SHOWN ARE BASED ON A 8" DEPTH OF FOOTING, ADD INCREMENTAL QUANTITY FOR EACH ADDITIONAL 1" OF DEPTH.

SPECIFICATION REFERENCE
105
232
302

STANDARD SPRING BOX

VIRGINIA DEPARTMENT OF TRANSPORTATION

VDOT	
ROAD AND BRIDGE STANDARDS	
REVISION DATE	SHEET 1 OF 1
	110.01

SB-1 PC

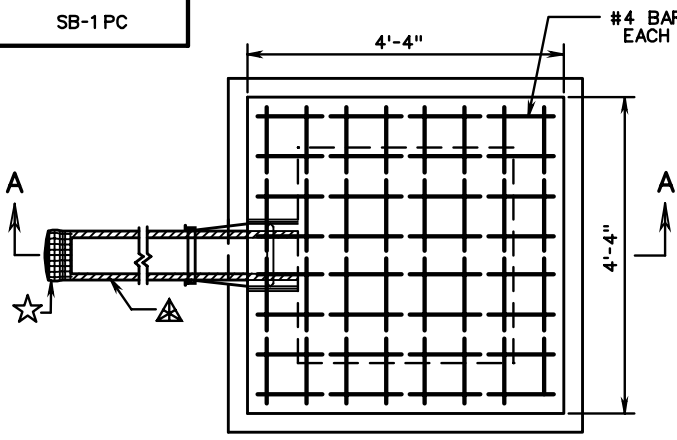

PLAN
(SQUARE)

#4 BARS @ 6" C-C EACH WAY

☆ 3/4"x3/4" MESH HARDWARE CLOTH, MIN. 17 GAUGE GALVANIZED AFTER WEAVING.

▲ CRIMP AROUND OUTLET END OF PIPE AND SECURE TO PIPE WITH GALVANIZED STEEL WIRE.

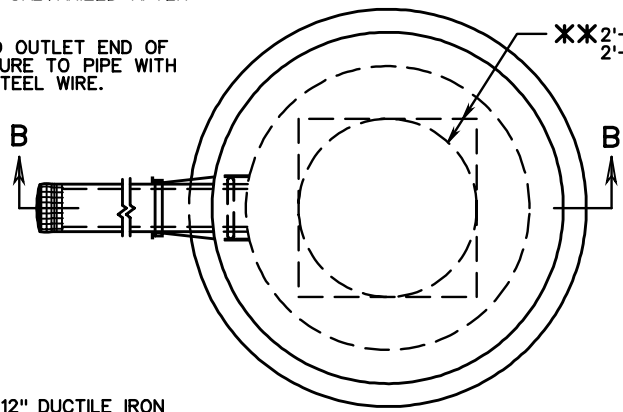

PLAN
(CIRCULAR)

XX 2'-6"x2'-6" OR 2'-6" DIAMETER

* STANDARD RECOMMENDED PIPE IS 12" DUCTILE IRON WATER LINE, PUSH ON JOINTS, CLASS TO BE SPECIFIED BASED UPON HEIGHT OF COVER.

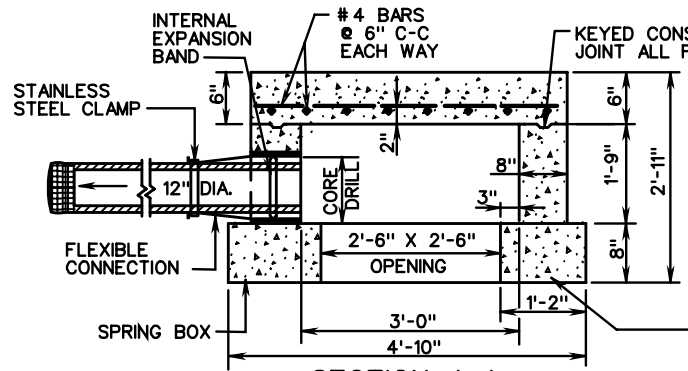

SECTION A-A

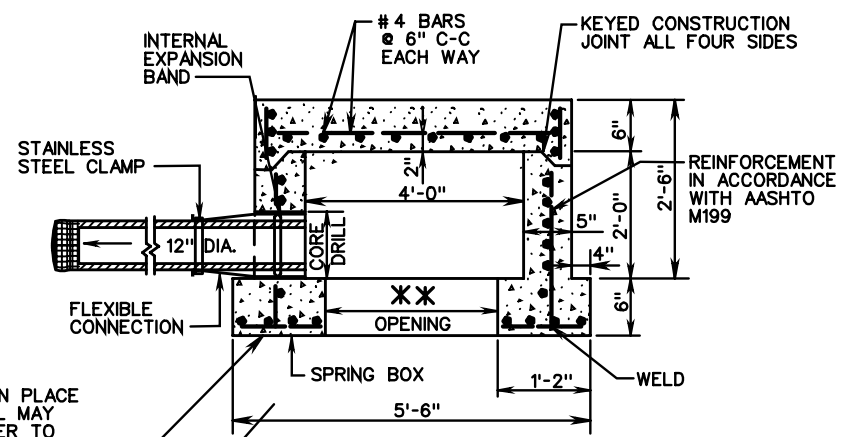

SECTION B-B

ADDITIONAL POURED IN PLACE FOUNDATION MATERIAL MAY BE REQUIRED IN ORDER TO REACH FIRM FOUNDATION.

NOTES:

CONCRETE TO BE 4000 PSI MINIMUM COMPRESSIVE STRENGTH.

REINFORCING STEEL IN ACCORDANCE WITH A.S.T.M. A-615 (REINFORCING BARS).

PIPE(S) SHALL BE CONNECTED TO SPRING BOX WITH A FLEXIBLE BOOT MEETING ASTM SPECIFICATION C-923. COST OF FLEXIBLE CONNECTION TO BE INCLUDED IN BID PRICE FOR SPRING BOX. BOOT SHALL BE MADE FROM NEOPRENE RUBBER AND HAVE A 3/8" MINIMUM WALL THICKNESS THROUGHOUT. THE INTERNAL EXPANSION BAND TO SECURE THE BOOT IN PLACE SHALL CONFORM TO ALUMINUM MATERIAL SPECIFICATION 6061-T6. THE EXTERNAL BAND TO CLAMP AND SEAL THE BOOT TO THE PIPE SHALL BE STAINLESS STEEL-CORROSION RESISTANT CONFORMING TO ASTM SPECIFICATION A-167. THE OPENING TO RECEIVE THE FLEXIBLE CONNECTION SHALL BE CORE DRILLED AND IS TO BE CONSTRUCTED TO ALLOW FOR LATERAL AND VERTICAL MOVEMENT, AS WELL AS ANGULAR ADJUSTMENT THRU 20 DEGREES. ALL FIELD INSTALLATION OF PIPE TO SPRING BOX USING FLEXIBLE BOOT SHALL BE COMPLETED IN ACCORDANCE WITH THE MANUFACTURER'S RECOMMENDATIONS AND SPECIFICATIONS.

DIMENSIONS SHOWN ARE MINIMUM. ACTUAL MEASUREMENTS MAY VARY WITH MANUFACTURER'S TOLERANCES.

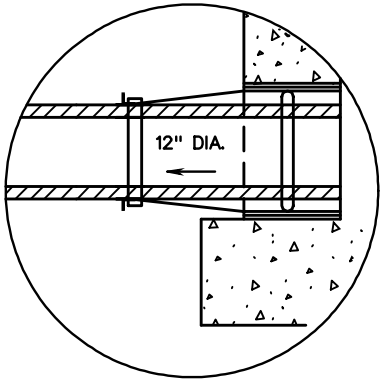

ROAD AND BRIDGE STANDARDS

SHEET 1 OF 1

REVISION DATE

110.02

PRECAST SPRING BOX

VIRGINIA DEPARTMENT OF TRANSPORTATION

SPECIFICATION REFERENCE

105

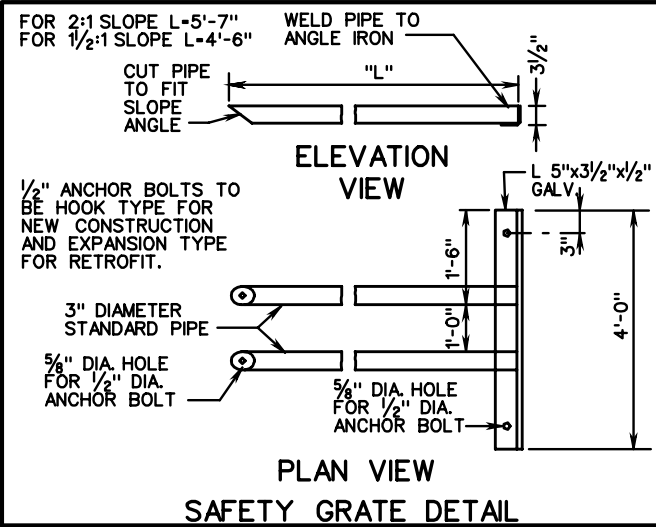
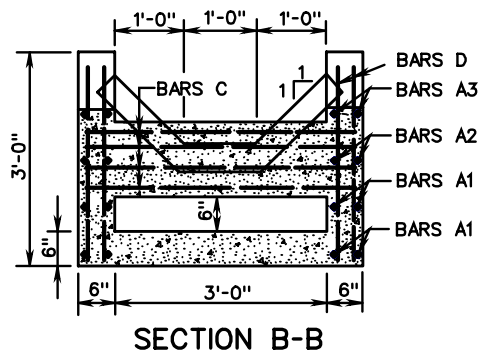
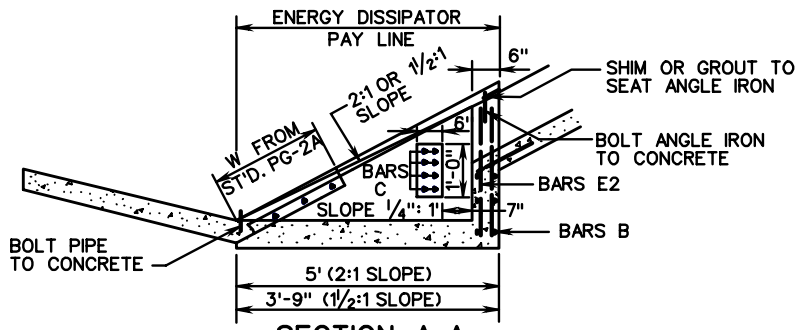
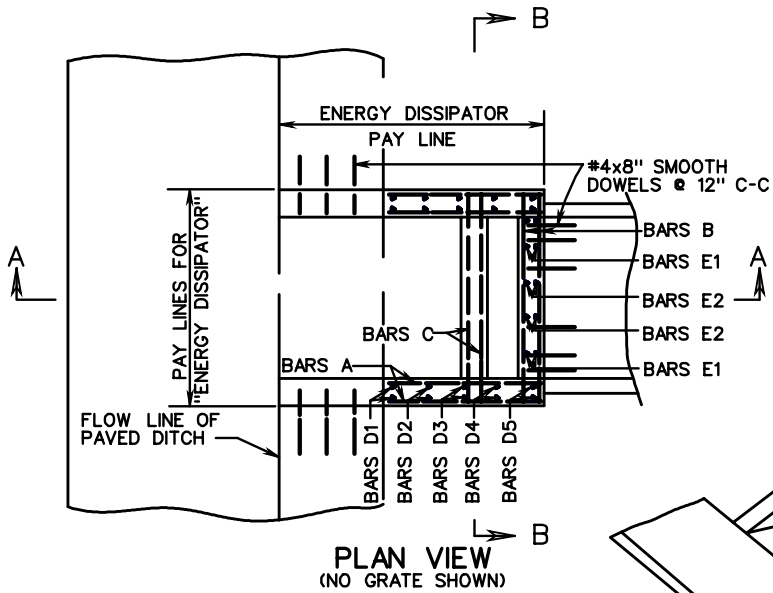

NOTES:

AMOUNT OF PAVED DITCH REPLACED BY "ENERGY DISSIPATOR" TABULATED BY DEPTHS AS SHOWN IN STANDARD PG-2A.

THIS ITEM MAY BE PRECAST OR CAST IN PLACE.

CONCRETE TO BE CLASS A3 IF CAST IN PLACE.

FOR PRECAST SEE SHEET 111.02.

THE 2:1 DESIGN MAY BE USED ON EITHER 1/2:1 OR 2:1 SLOPES.

EG-1-ENERGY DISSIPATOR WITHOUT GRATE.
EG-1A-ENERGY DISSIPATOR WITH GRATE.

SCHEDULE OF REINFORCING STEEL						
MARK	NO.	LENGTH		SIZE	SPACING C-C	SHAPE
		2:1	1 1/2:1			
A1	8	2'-10"	2'-10"	# 3	8"	STRAIGHT
A2	4	2'-6 1/4"	1'-10"	# 3	8"	STRAIGHT
A3	4	1'-0 3/4"	0'-10"	# 3	8"	STRAIGHT
B	6	3'-9"	3'-9"	# 3	8"	STRAIGHT
C	8	3'-8"	3'-8"	# 4	2 1/2"	STRAIGHT
D1	4	1'-2 1/2"	0'-8"	# 3	8"	STRAIGHT
D2	4	1'-6 1/2"	1'-1 1/2"	# 3	8"	STRAIGHT
D3	4	1'-10 1/2"	1'-7"	# 3	8"	STRAIGHT
D4	4	2'-2 1/2"	2'-0 1/2"	# 3	8"	STRAIGHT
D5	4	2'-6 1/2"	2'-6"	# 3	8"	STRAIGHT
E1	4	1'-11 1/2"	1'-11 1/2"	# 3	8"	STRAIGHT
E2	4	1'-5 1/2"	1'-5 1/2"	# 3	8"	STRAIGHT

APPROXIMATE QUANTITIES			
		CONCRETE	REINFORCING STEEL
		CU. YDS.	LBS.
ENERGY DISSIPATOR	2:1	0.7479	61.20
	1/2:1	0.5921	57.63

SPECIFICATION REFERENCE
502

STANDARD ENERGY DISSIPATOR
FOR USE WITH PAVED FLUMES
VIRGINIA DEPARTMENT OF TRANSPORTATION

VDOT	
ROAD AND BRIDGE STANDARDS	
REVISION DATE	SHEET 1 OF 1
	111.01

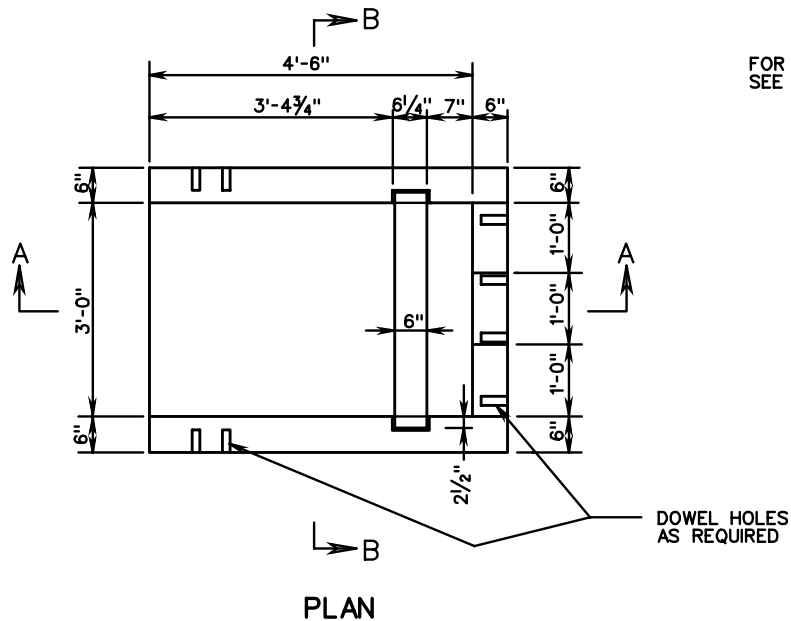

FOR DETAILS OF SAFETY GRATE
SEE ST'D. EG-1

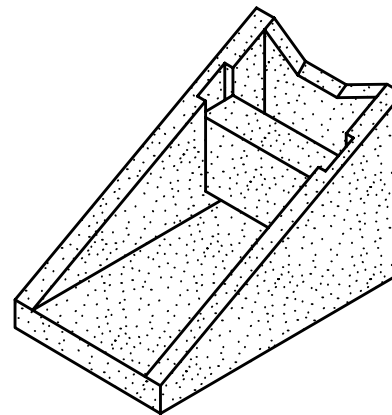

ISOMETRIC VIEW

EG-1 PC-ENERGY DISSIPATOR (WITHOUT GRATE)
EG-1A PC-ENERGY DISSIPATOR (WITH GRATE)

1. CONCRETE STRENGTH 4000 PSI MINIMUM.
2. REINFORCING SHALL CONFORM TO A.S.T.M. A615, GRADE 40.
3. ALL UNITS SHALL BE FOR A 2:1 SLOPE UNLESS SPECIAL ORDERED.
4. DOWEL HOLES PROVIDED TO PREVENT SETTLEMENT OF ADJACENT CONCRETE.
5. DIMENSIONS SHOWN FOR CONCRETE THICKNESS ARE MINIMUM. ACTUAL MEASUREMENTS MAY VARY WITH MANUFACTURER'S TOLERANCES.

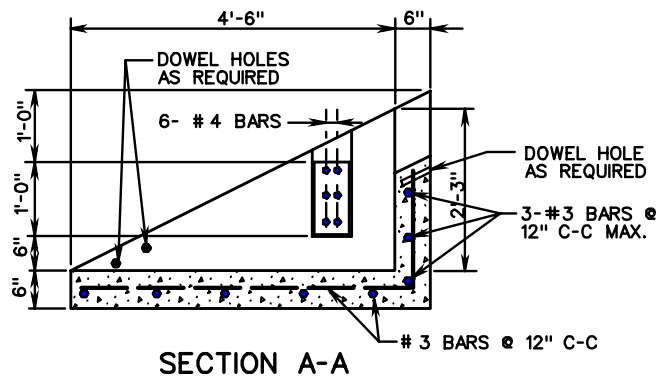

SECTION A-A

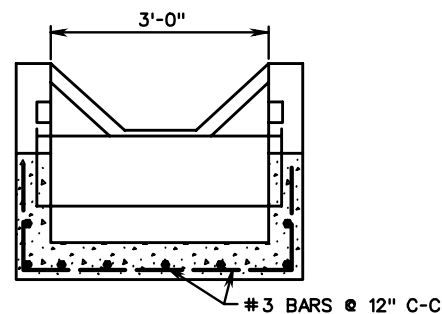

SECTION B-B



ROAD AND BRIDGE STANDARDS

SHEET 1 OF 1

REVISION DATE

111.02

PRECAST ENERGY DISSIPATOR

VIRGINIA DEPARTMENT OF TRANSPORTATION

SPECIFICATION
REFERENCE

105

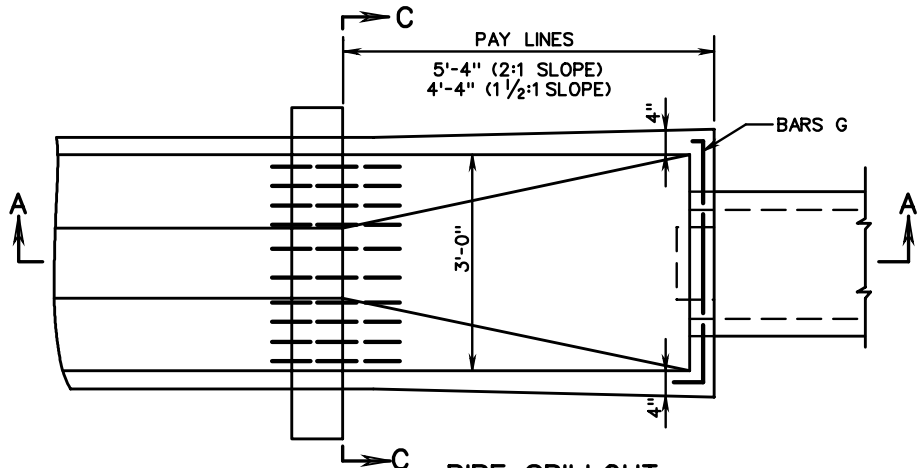

PIPE SPILLOUT
PLAN VIEW

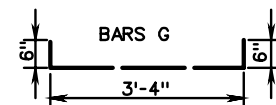

- * 12" PIPE - 3 BARS - 10.68 LBS. REINFORCING STEEL
- 15" PIPE - 2 BARS - 7.79 LBS. REINFORCING STEEL
- 18" PIPE - 2 BARS - 7.79 LBS. REINFORCING STEEL

SCHEDULE OF REINFORCING STEEL						
MARK	NO.	LENGTH		SIZE	SPACING C-C	SHAPE
		2:1	1/2:1			
F	5	1'-0"	1'-0"	4	4"	STRAIGHT
G	*	4'-4"	4'-4"	4	4"	BENT
L	12	2'-0"		3	12"	BENT
L	10		2'-0"	3	12"	BENT

‡ QUANTITIES BASED
ON 18" PIPE.

APPROXIMATE QUANTITIES			
PIPE SPILLOUT	SLOPE	CLASS A3 CONCRETE	REINFORCING STEEL
		CUBIC YARDS	LBS.
PIPE	2:1	‡ 0.482	*
SPILLOUT	1/2:1	‡ 0.440	*

NOTE:
DOWELS TO BE LOCATED AT ALL
REQUIRED JOINTS.

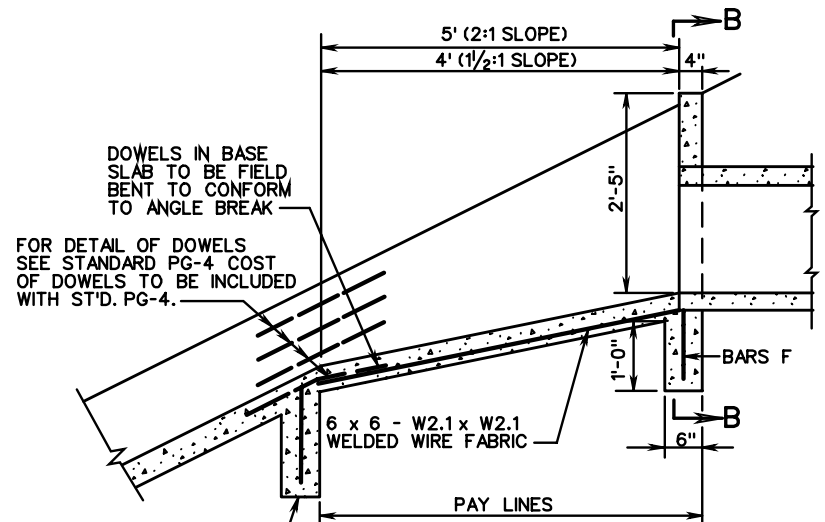

PIPE SPILLOUT
SECTION A-A

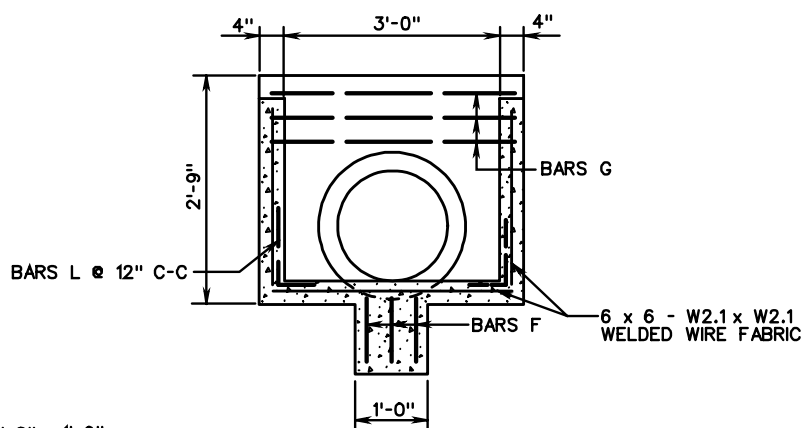

SECTION B-B

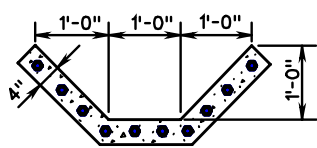

SECTION C-C

SPECIFICATION REFERENCE
302

STANDARD PIPE SPILLOUT FOR 12" - 18" PIPE CULVERTS

VIRGINIA DEPARTMENT OF TRANSPORTATION

VDOT ROAD AND BRIDGE STANDARDS	
REVISION DATE	SHEET 1 OF 1
112.01	

PS-3

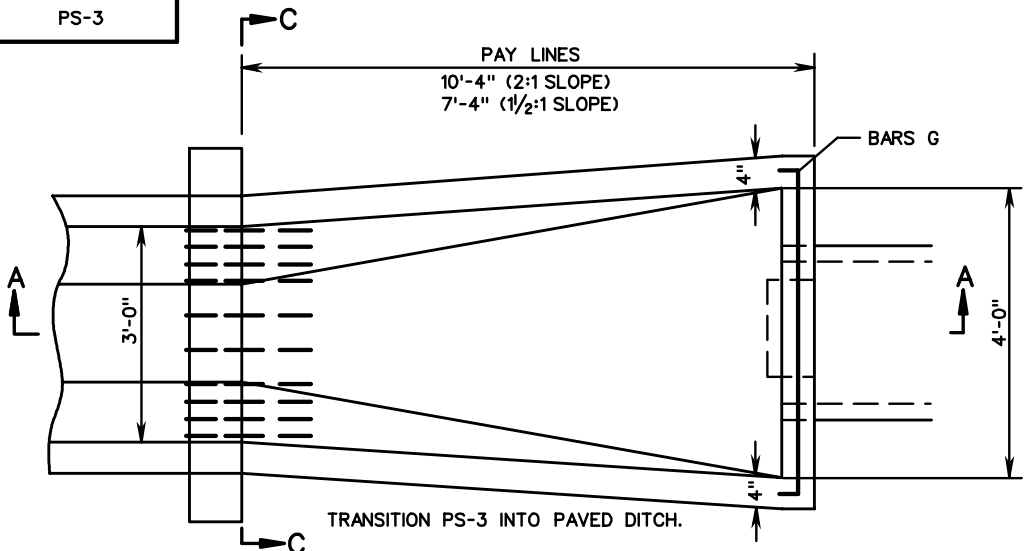

PIPE SPILLOUT
PLAN VIEW

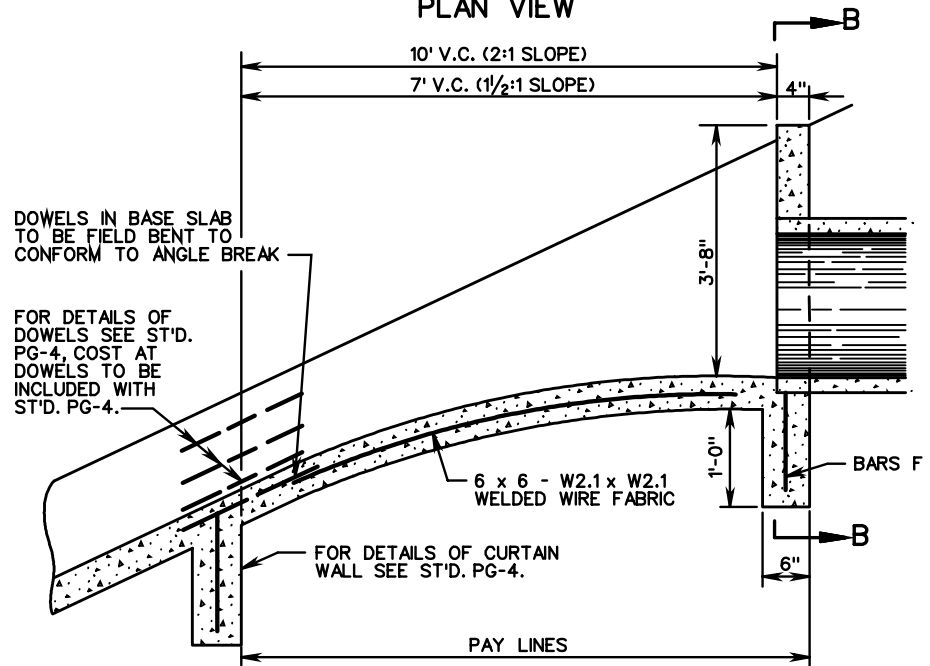

PIPE SPILLOUT
SECTION A-A

DOWELS IN BASE SLAB
TO BE FIELD BENT TO
CONFORM TO ANGLE BREAK

FOR DETAILS OF
DOWELS SEE ST'D.
PG-4, COST AT
DOWELS TO BE
INCLUDED WITH
ST'D. PG-4.

FOR DETAILS OF CURTAIN
WALL SEE ST'D. PG-4.

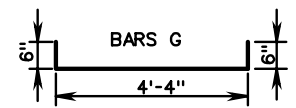

- * 30" PIPE = 2 BARS - 10.46 LBS. REINFORCING STEEL
- 24" PIPE = 4 BARS - 17.59 LBS. REINFORCING STEEL
- 21" PIPE = 5 BARS - 21.15 LBS. REINFORCING STEEL

SCHEDULE OF REINFORCING STEEL						
MARK	NO.	LENGTH		SIZE	SPACING C-C	SHAPE
		2:1	1/2:1			
F	5	1'-0"	1'-0"	4	4"	STRAIGHT
G	*	5'-4"	5'-4"	4	4"	BENT
L	22	2'-0"		3	12"	BENT
L	16		2'-0"	3	12"	BENT

‡ QUANTITIES BASED ON 30" PIPE.

APPROXIMATE QUANTITIES			
PIPE SPILLOUT	SLOPE	CLASS A3 CONCRETE	REINFORCING STEEL
		CU. YARDS.	LBS.
	2:1	‡ 1.351	*
	1/2:1	‡ 1.037	*

NOTE:
DOWELS TO BE LOCATED AT ALL REQUIRED JOINTS.

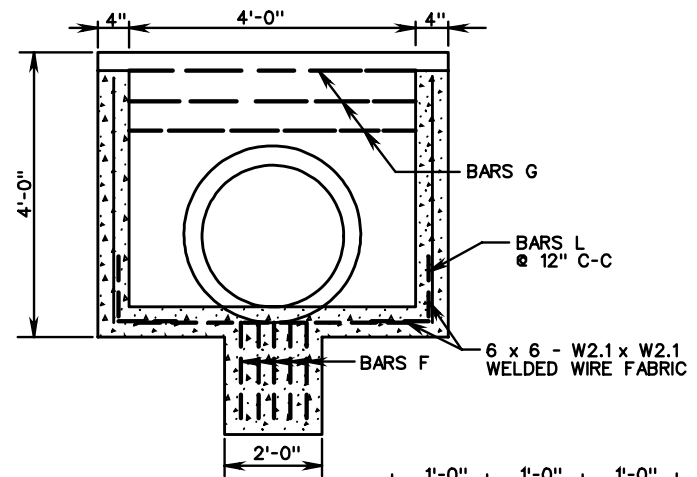

SECTION B-B

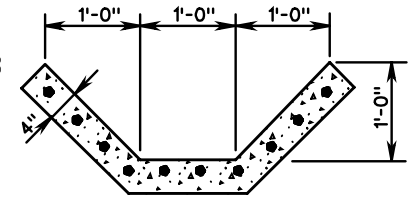

SECTION C-C



ROAD AND BRIDGE STANDARDS

SHEET 1 OF 1

REVISION DATE

112.02

STANDARD PIPE SPILLOUT FOR 21" - 30" PIPE CULVERTS

VIRGINIA DEPARTMENT OF TRANSPORTATION

SPECIFICATION
REFERENCE

302

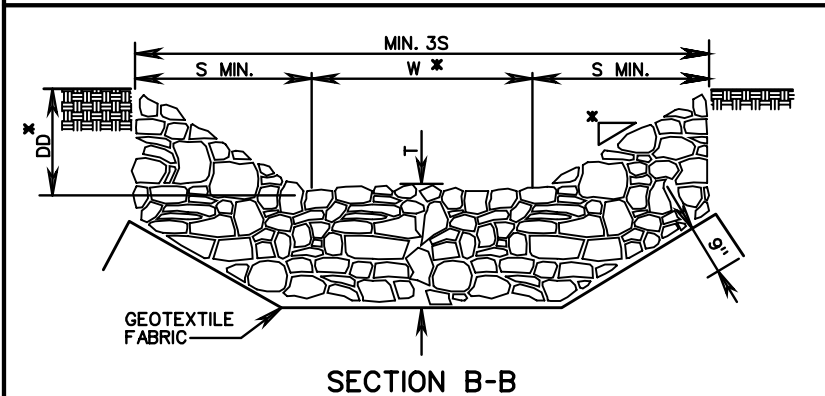
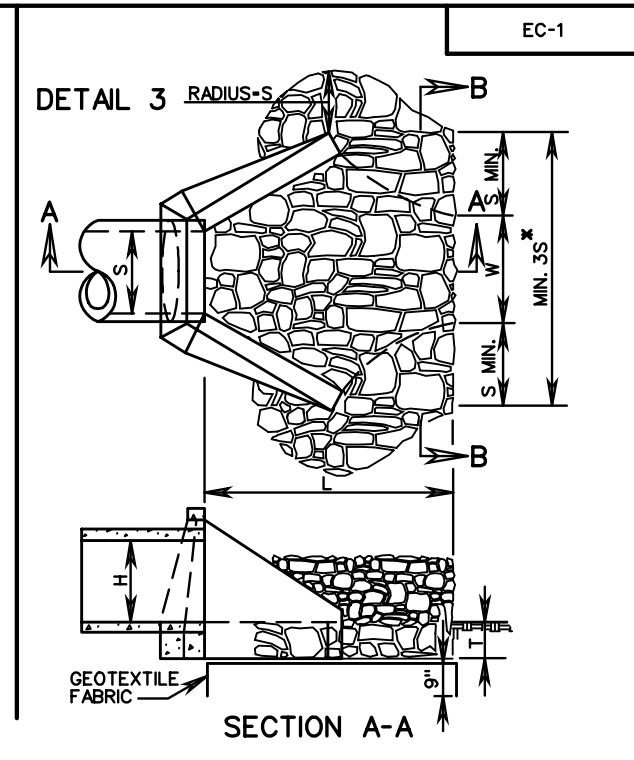
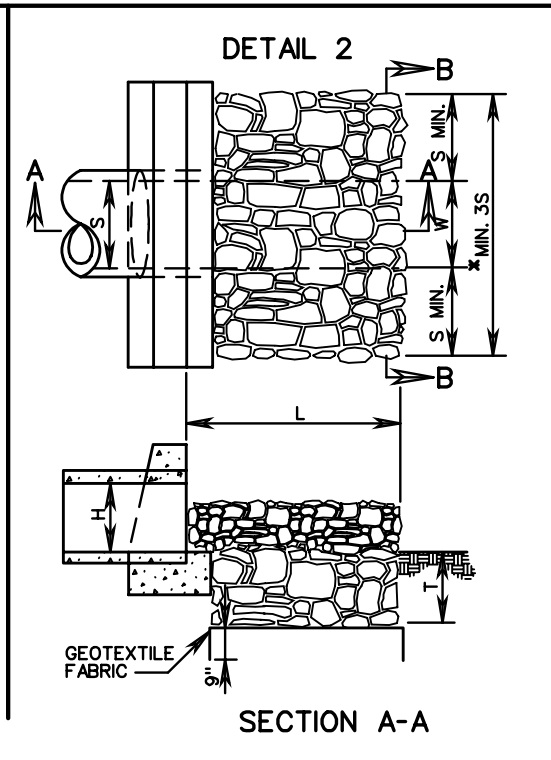
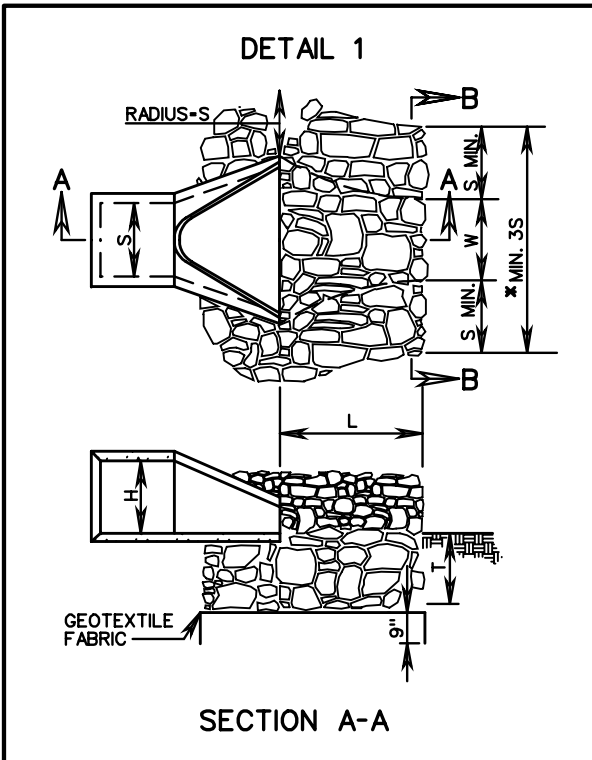

NOTES:

1. FOR MULTIPLE LINE INSTALLATIONS, DIMENSION S IS TO GOVERN THE PROTECTION OUTSIDE THE CHANNEL WIDTH (W).
 2. ON ANY INSTALLATION REQUIRING CULVERT OUTLET PROTECTION WHERE NO ENDWALL OR ENDSECTION IS SPECIFIED ON THE PLANS, CONSTRUCTION IS TO BE IN ACCORDANCE WITH DETAIL 2 SHOWN ABOVE.
 3. GEOTEXTILE FABRIC TO BE INSTALLED UNDER CLASS A1, I, AND II MATERIALS IN ACCORDANCE WITH THE SPECIFICATIONS.
 4. S = DIAMETER OF CIRCULAR CULVERT OR SPAN FOR BOX, ELLIPTICAL OR ARCH CULVERT. H = DIAMETER OF CIRCULAR CULVERT OR RISE/HEIGHT FOR BOX, ELLIPTICAL OR ARCH CULVERT.
- * USE TYPICAL SECTION SHOWN ON PLANS FOR SIDE SLOPE, BOTTOM WIDTH AND DEPTH OF CHANNEL OR MATCH EXISTING DITCH OR NATURAL GROUND.

TYPE OF OUTLET PROTECTION MATERIAL		MAXIMUM OUTLET VELOCITY (FOR DESIGN STORM)	MINIMUM "T" (INCHES)
CLASS A1	CLASS A1 DRY RIPRAP	8 fps	18
CLASS I	CLASS I DRY RIPRAP	14 fps	24
CLASS II	CLASS II DRY RIPRAP	19 fps	36

OUTLET PROTECTION MINIMUM LENGTH (L)	
TYPE A INSTALLATION	3H
TYPE B INSTALLATION	5H

SPECIFICATION REFERENCE
204
245
303
414

CULVERT OUTLET PROTECTION

VIRGINIA DEPARTMENT OF TRANSPORTATION

VDOT ROAD AND BRIDGE STANDARDS	
REVISION DATE	SHEET 1 OF 1
113.01	

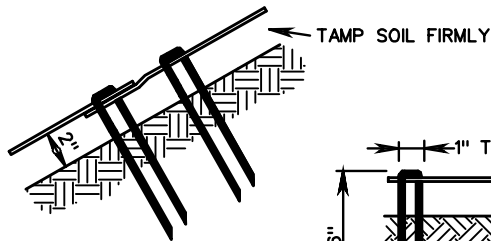
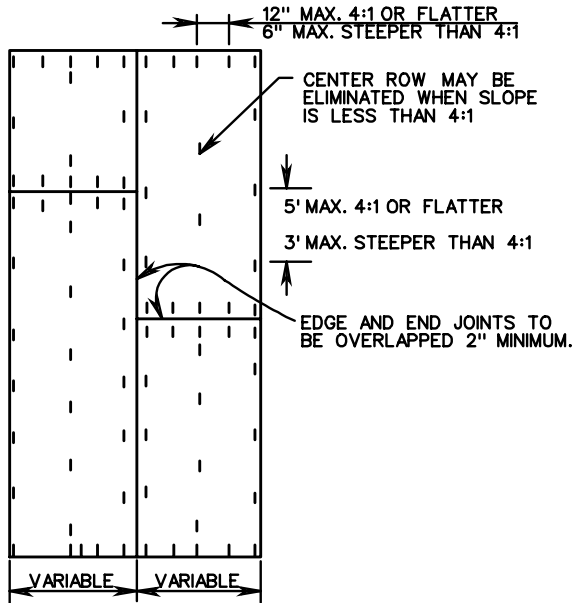

JUNCTION SLOT

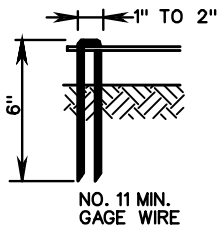

SOIL RETENTION MAT

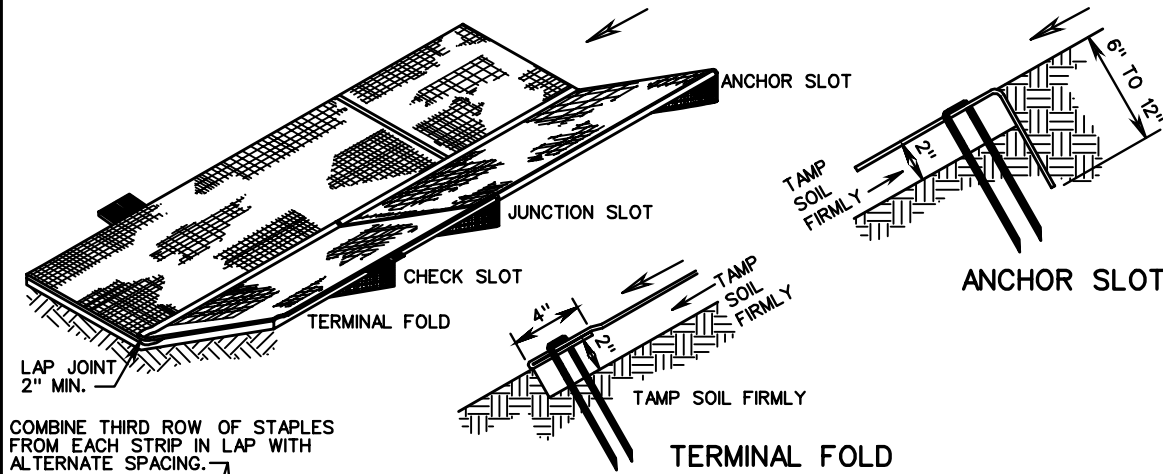

COMBINE THIRD ROW OF STAPLES FROM EACH STRIP IN LAP WITH ALTERNATE SPACING.

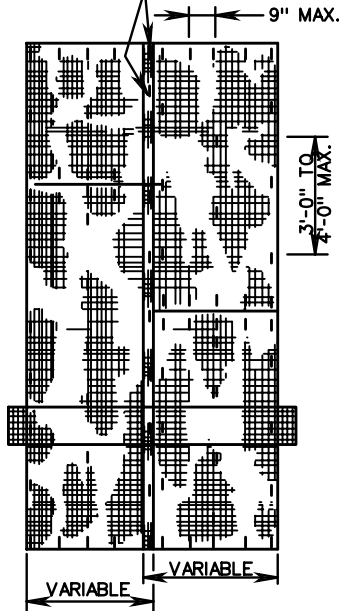

PLAN VIEW STAPLING DIAGRAM

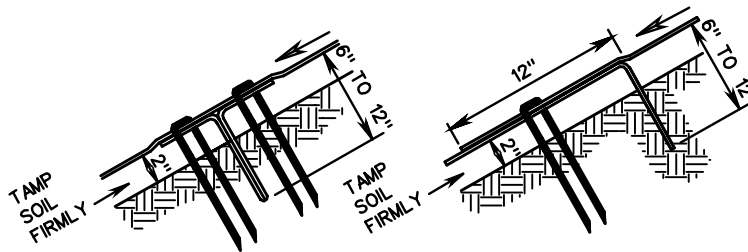

CHECK SLOT

JUNCTION SLOT

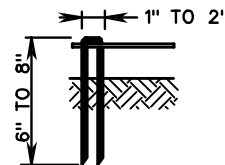

JUTE MESH

NOTES:

1. APPROXIMATE 200 STAPLES REQUIRED PER 4' X 225' ROLL.
2. ANCHOR SLOTS, JUNCTION SLOTS AND CHECK SLOTS TO BE BURIED 6" TO 12" AND VARIABLE.
3. MAX. SPACING C-C CHECK SLOTS 100' SLOPE 4% OR LESS 50' SLOPE STEEPER THAN 4%.
4. STAPLES FORMED FROM NO. 8 STEEL WIRE 8" STAPLE MINIMUM LENGTH FOR SANDY SOIL 6" STAPLE MINIMUM LENGTH FOR OTHER SOIL.

GENERAL NOTES:

1. BASIS OF PAYMENT TO BE SQUARE YARDS OF PROTECTIVE COVERING COMPLETE IN PLACE. PROTECTIVE COVERING IS TO BE LOCATED AS INDICATED ON THE PLANS IN ACCORDANCE WITH THE DIMENSIONS SPECIFIED ON TYPICAL SECTION.
2. "T-TOP" STAPLES OR OTHER MANUFACTURER'S DESIGN APPROVED BY THE ENGINEER MAY BE SUBSTITUTED FOR THE STAPLES SHOWN.
3. JUTE MESH OR SOIL RETENTION MAT IN ACCORDANCE WITH THE SPECIFICATIONS MAY BE USED AT THE OPTION OF THE CONTRACTOR.
4. WIDTH OF MATERIAL MAY VARY FROM MINIMUM DIMENSION BY INCREMENTS OF 4 OR 5 FEET.
5. FOR SOURCES OF APPROVED MATERIAL SEE VDOT'S APPROVED PRODUCTS LIST FOR ST'D. EC-2 MATERIAL.



ROAD AND BRIDGE STANDARDS

SHEET 1 OF 1

REVISION DATE

113.02

PROTECTIVE COVERING INSTALLATION CRITERIA

VIRGINIA DEPARTMENT OF TRANSPORTATION

SPECIFICATION REFERENCE

244
606

TYPICAL INSTALLATION AT END OF PIPE

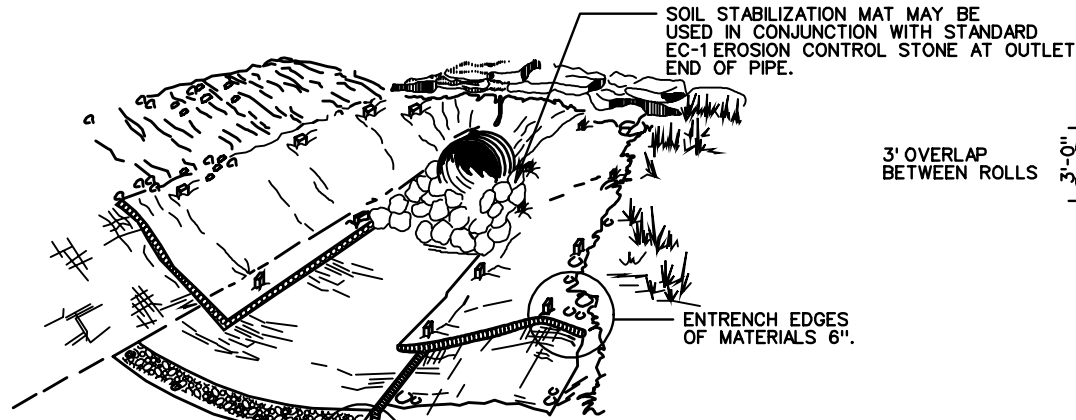

STAKING DETAIL

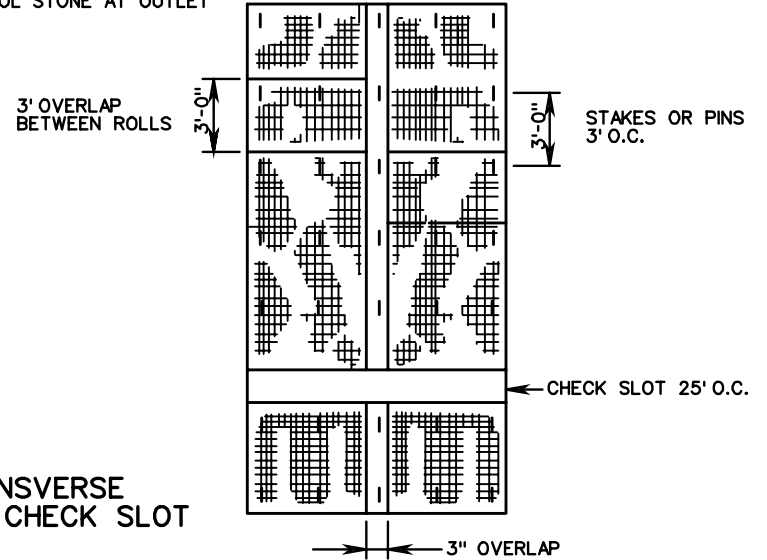

* TRANSVERSE CLOSED CHECK SLOT

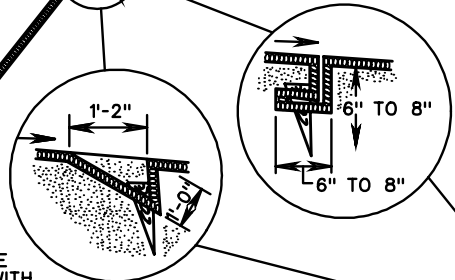

* TRANSVERSE OPEN CHECK SLOT

* TRANSVERSE CHECK SLOT TO BE CONSTRUCTED IN ACCORDANCE WITH THE MANUFACTURER'S RECOMMENDATION FOR PREFERRED INSTALLATION.

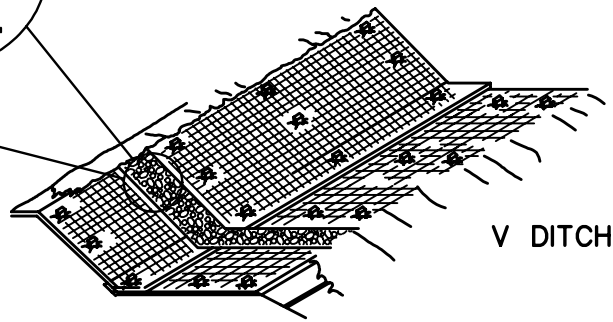

V DITCH

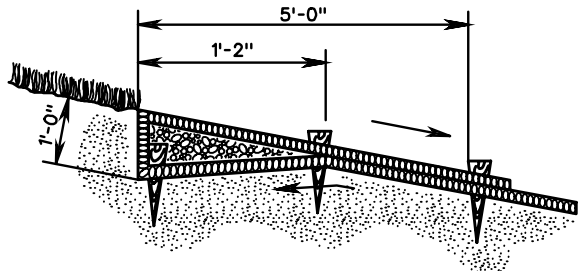

UPSTREAM AND DOWNSTREAM TERMINAL

NOTES:

1. STAKES SHALL BE WOOD OR METAL AS RECOMMENDED BY THE MANUFACTURER AND SHALL BE A MINIMUM OF 12" IN LENGTH. IN SANDY SOILS METAL STAKES A MINIMUM OF 18" IN LENGTH SHALL BE USED.
2. SOIL STABILIZATION MAT TYPE A AND B ARE TO BE IN ACCORDANCE WITH THE APPROVED PRODUCTS LIST.
3. SOIL STABILIZATION MAT SHOULD BE INSTALLED TO THE SHOULDER BREAK POINT OR EXISTING GROUND THEN EMBEDDED 6". MATERIAL ON BOTH SIDES OF THE DITCH SHALL BE INSTALLED TO THE SAME ELEVATIONS.
4. IF MORE THAN 3 LINES OF MATERIAL ARE REQUIRED PARALLEL TO THE C OF THE DITCH, MATERIAL SHALL BE INSTALLED PERPENDICULAR TO THE CENTER LINE OF THE DITCH, STARTING AT THE LOWEST C ELEVATION OF THE DITCH.
5. FOR SOURCES OF APPROVED MATERIALS SEE VDOT'S APPROVED PRODUCTS LIST FOR ST'D. EC-3, TYPE A OR B.

SPECIFICATION REFERENCE
244 606

SOIL STABILIZATION MAT
DITCH INSTALLATION TYPE A OR B

VIRGINIA DEPARTMENT OF TRANSPORTATION

VDOT	
ROAD AND BRIDGE STANDARDS	
REVISION DATE	SHEET 1 OF 3
	113.03

DETAIL 1

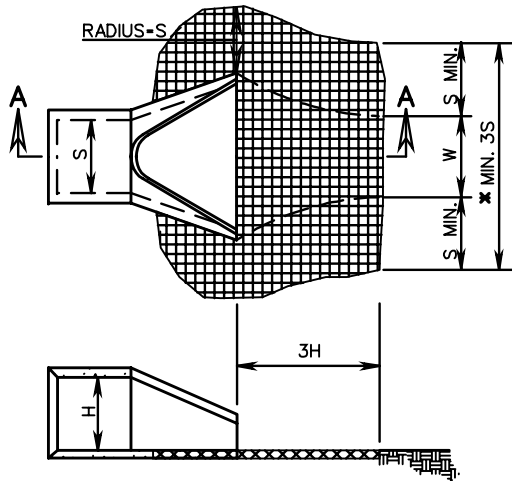

SECTION A-A

DETAIL 2

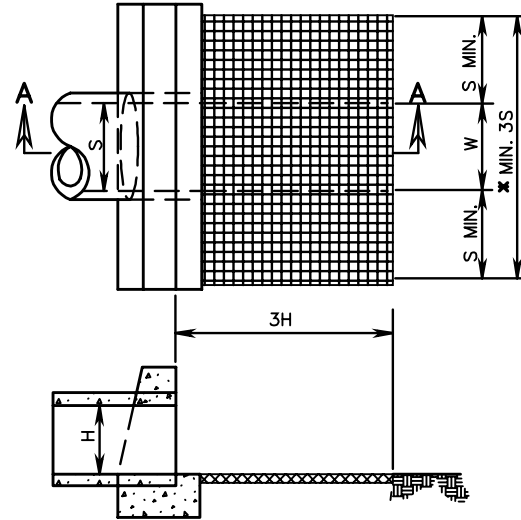

SECTION A-A

NOTES:

1. FOR MULTIPLE LINE INSTALLATIONS, DIMENSION S IS TO GOVERN THE PROTECTION OUTSIDE THE CHANNEL WIDTH (W).
 2. ON ANY INSTALLATION REQUIRING CULVERT OUTLET PROTECTION WHERE NO ENDWALL OR ENDSECTION IS SPECIFIED ON THE PLANS, CONSTRUCTION IS TO BE IN ACCORDANCE WITH DETAIL 2 SHOWN ABOVE.
 3. SOIL STABILIZATION MAT TYPE B SHALL BE USED FOR CULVERT OUTLET PROTECTION WHERE THE OUTLET VELOCITY IS 6 FPS OR LESS FOR THE DESIGN STORM AND THE TOTAL HYDRAULIC OPENING IS LESS THAN 7 SQUARE FEET. IF THE TOTAL HYDRAULIC OPENING IS 7 SQUARE FEET OR GREATER, OR THE DESIGN STORM OUTLET VELOCITY IS GREATER THAN 6 FPS USE STANDARD EC-1.
 4. S = DIAMETER OF CIRCULAR CULVERT OR SPAN FOR BOX, ELLIPTICAL OR ARCH CULVERT.
H = DIAMETER OF CIRCULAR CULVERT OR RISE/HEIGHT FOR BOX, ELLIPTICAL OR ARCH CULVERT.
- * USE TYPICAL SECTION SHOWN ON PLANS FOR SIDE SLOPE, BOTTOM WIDTH AND DEPTH OF CHANNEL OR MATCH EXISTING DITCH OR NATURAL GROUND.



ROAD AND BRIDGE STANDARDS

SHEET 2 OF 3

REVISION DATE

113.04

SOIL STABILIZATION MAT CULVERT OUTLET PROTECTION INSTALLATION

VIRGINIA DEPARTMENT OF TRANSPORTATION

SPECIFICATION
REFERENCE

204
245
303
414

FILL SLOPE SECTION

DROP STD EC-3 MATERIAL VERTICALLY DOWNSLOPE

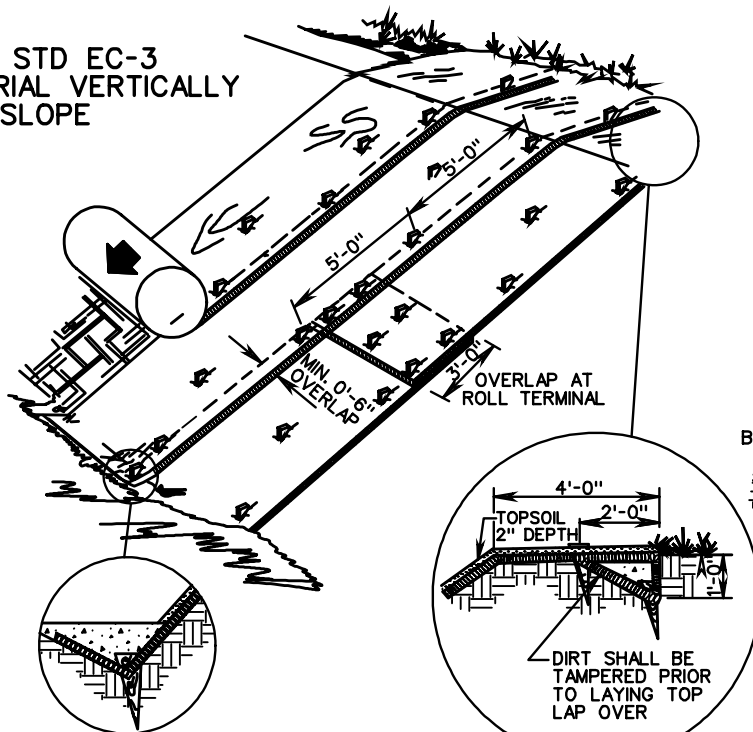

TOE OF FILL

MAINTAIN SLOPE ANGLE

BERM

TRENCH INTO BERM AND PROGRESS DOWNSLOPE

NOTE:

1. SLOPE SURFACE SHALL BE SMOOTH AND FREE OF ROCKS, LUMPS OF DIRT, GRASS, AND STICKS. MAT SHALL BE PLACED FLAT ON SURFACE FOR PROPER SOIL CONTACT.
2. STAKES SHALL BE WOOD OR METAL AS RECOMMENDED BY THE MANUFACTURER AND SHALL BE A MINIMUM OF 18 INCHES IN LENGTH.
3. BASIS OF PAYMENT SHALL BE SQUARE YARDS OF STANDARD EC-3 (TYPE C) IN PLACE.
4. SOIL STABILIZATION MAT TYPE C SHALL BE IN ACCORDANCE WITH THE APPROVED PRODUCT LIST.
5. TOPSOIL SHALL BE SPREAD TO A UNIFORM THICKNESS PRIOR TO APPLICATION OF SEED AND MULCH.
6. FOR SOURCES OF APPROVED MATERIALS SEE VDOT'S APPROVED PRODUCTS LIST FOR ST'D. EC-3, TYPE C MATERIALS.
7. SLOPES 1/2:1 AND FLATTER SHALL BE BACKFILLED WITH TOPSOIL AT 2 INCH DEPTH. SEED SHALL BE APPLIED TO THE TOPSOIL AND MULCHED WITH TYPE I MULCH.
8. SLOPES STEEPER THAN 1/2:1 SHALL BE SEEDED IMMEDIATELY PRIOR TO INSTALLATION OF ST'D. EC-3 TYPE C MATERIAL.

SLOPE LINING - WET SLOPE

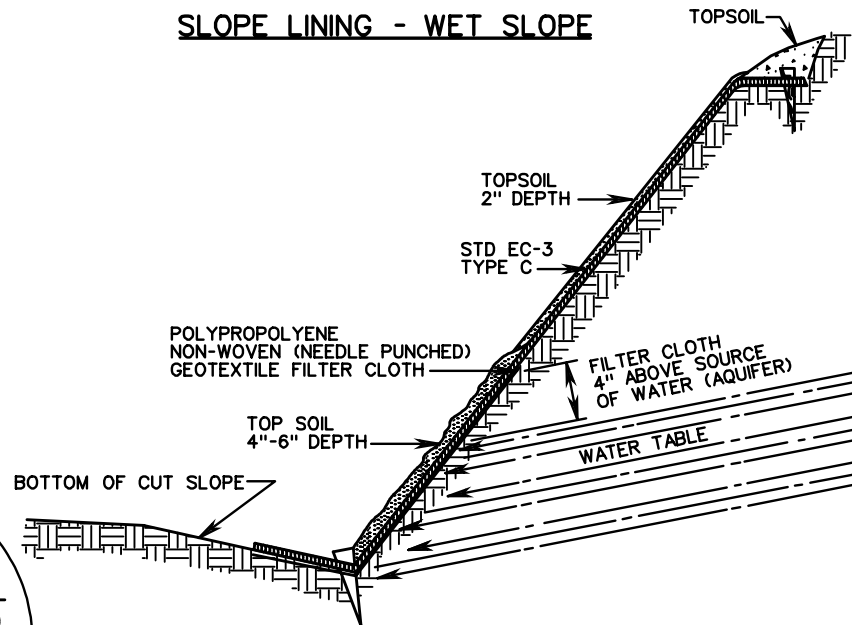

SLOPE LINING - DRY SLOPE

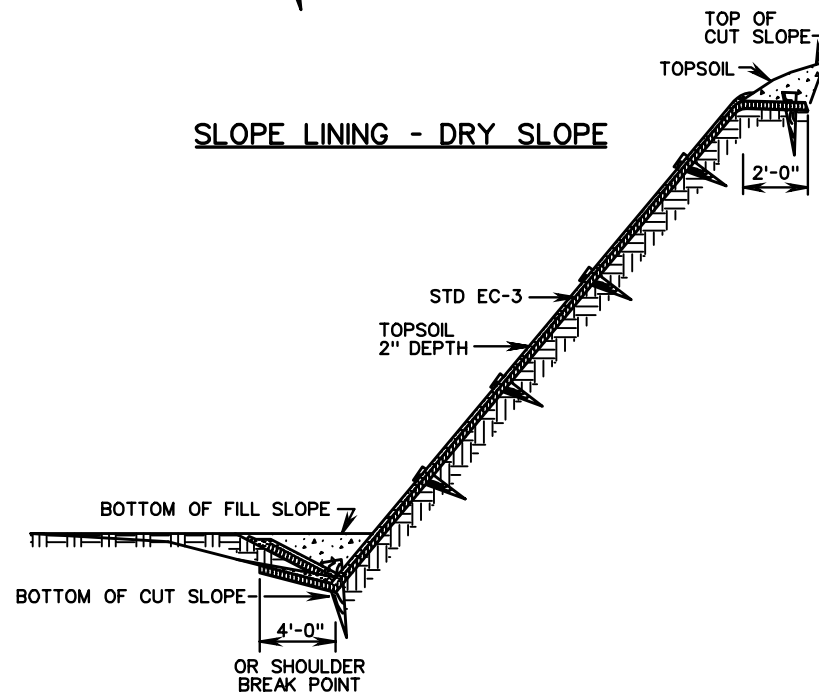

SPECIFICATION REFERENCE

244
606

SOIL STABILIZATION MAT - SLOPE INSTALLATION TYPE C

VIRGINIA DEPARTMENT OF TRANSPORTATION

VDOT

ROAD AND BRIDGE STANDARDS

REVISION DATE

SHEET 3 OF 3

113.05

TYPICAL DETAIL FOR ROCK CHECK DAM TYPE I

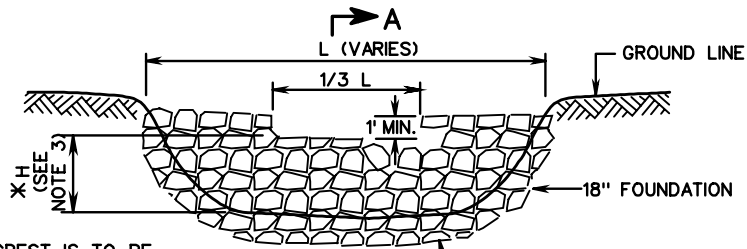

* HEIGHT (H) OF CREST IS TO BE 3'± IF CHANNEL OR SWALE IS DEEP ENOUGH OR AS DESIGNATED BY DESIGNER.

FRONT ELEVATION

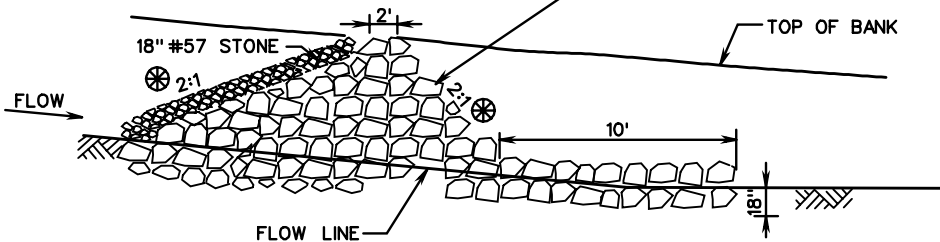

SECTION A-A

TYPICAL DETAIL FOR ROCK CHECK DAM TYPE II

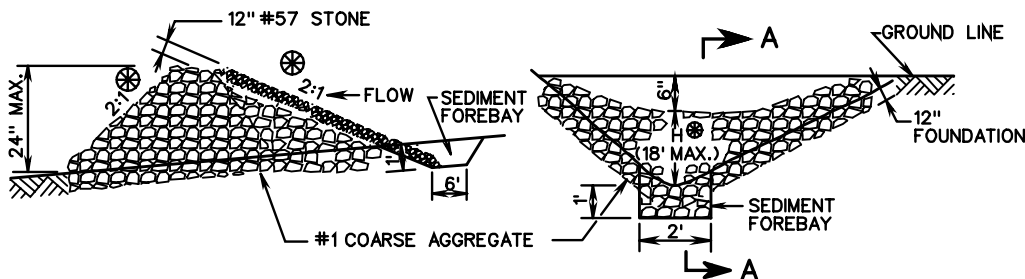

SECTION A-A

FRONT ELEVATION

SUGGESTED ROCK CHECK DAM SPACING

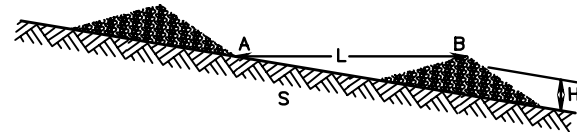

L = H/S WHERE:
 H - HEIGHT OF DAM CREST IN FEET
 S - CHANNEL SLOPE IN FT/FT
 L - CHECK DAM SPACING IN FEET; THE DISTANCE SUCH THAT POINTS A AND B ARE OF EQUAL ELEVATION

CHECK DAM SPACING, L TO BE DETERMINED FROM THE EQUATION. IN STEEP SLOPE AREAS THE CHECK DAM SPACING IS NOT TO BE LESS THAN 25'.

NOTES:

1. ROCK CHECK DAMS THAT ARE DESIGNATED ON THE PLANS AS A STORMWATER MANAGEMENT (SWM) ITEM ARE TO BE LEFT IN PLACE AS A PERMANENT INSTALLATION.
2. WHERE DRAINAGE AREAS EXCEED 1 ACRE OR DITCH GRADE EXCEEDS 3%, A TEMPORARY SEDIMENT FOREBAY SHALL BE INSTALLED WITH MINIMUM DIMENSIONS OF 12" DEPTH, 2' WIDTH AND 6' LENGTH.
3. IF CHECK DAMS IS LOCATED INSIDE CLEAR ZONE AND ADJACENT TO A TRAVELWAY, SLOPE FACING ON COMING TRAFFIC IS TO BE 6:1 AND MAXIMUM H IS TO BE 12".
4. ALTERNATIVE MATERIALS ON VDOT'S SPEL LIST MAY BE SUBSTITUTED AT NO ADDITIONAL COST TO THE DEPARTMENT.
5. SEE STANDARD EC-5 FOR DETAILS FOR ROCK CHECK DAMS IN ROADSIDE DITCHES
6. CHECK DAM SHALL NOT BE USED FOR LOCATIONS IN LIVE STREAM.



ROAD AND BRIDGE STANDARDS

SHEET 1 OF 1

REVISION DATE

113.06

ROCK CHECK DAMS TYPE I & II

VIRGINIA DEPARTMENT OF TRANSPORTATION

SPECIFICATION REFERENCE

107
303

TYPICAL DETAIL FOR TEMPORARY SILT FENCE/CHECK DAM AT TOE OF FILL

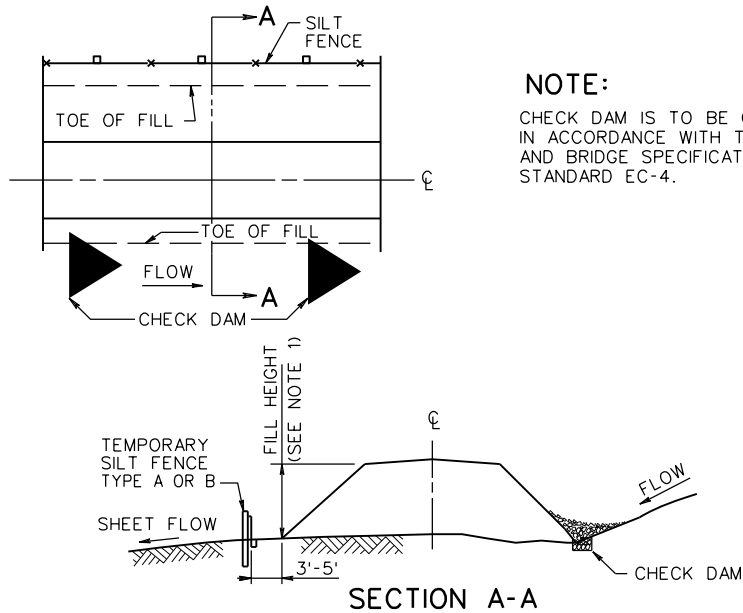

NOTE:
CHECK DAM IS TO BE CONSTRUCTED IN ACCORDANCE WITH THE ROAD AND BRIDGE SPECIFICATIONS, AND STANDARD EC-4.

TYPICAL DETAIL FOR TEMPORARY SILT FENCE/CHECK DAM AT CULVERT

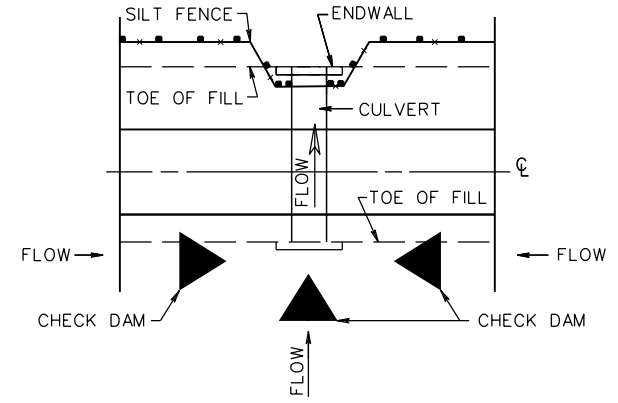

NOTE:
CHECK DAM IS TO BE CONSTRUCTED IN ACCORDANCE WITH THE ROAD AND BRIDGE SPECIFICATIONS, AND STANDARD EC-4.

NOTES FOR SILT FENCE TYPE A & B:

1. USE OF TYPE A SILT FENCE IS LIMITED TO A FILL HEIGHT OF 20 FEET OR LESS. TYPE B SILT FENCE MUST BE USED WHERE THE FILL HEIGHT EXCEEDS 20 FEET.
2. ALL POSTS SHALL BE DRIVEN 24" MIN. INTO THE GROUND AND SHALL EXTEND 6" ABOVE THE FILTER FABRIC (TYPE A) OR WIRE FENCE (TYPE B). WOODEN POSTS SHALL BE OAK AND HAVE MIN. DIMENSIONS OF 2" BY 2". STEEL POSTS SHALL HAVE A MINIMUM WEIGHT OF 1.33 POUNDS PER LINEAR FOOT.
3. GEOTEXTILE FABRIC SHALL BE EMBEDDED 12" INTO THE GROUND (6" VERTICALLY AND 6" HORIZONTALLY ALONG THE BOTTOM OF TRENCH) AS SHOWN IN DETAILS A(2) & B(2) ON SHEETS 2 AND 3.
4. SLICING IS AN APPROVED ALTERNATIVE TO TRENCHING FOR ANCHORING THE GEOTEXTILE FABRIC INTO THE GROUND SHOWN IN DETAILS A(2) & B(2) ON SHEETS 2 AND 3. SLICING SHALL BE ACCOMPLISHED IN ACCORDANCE WITH SECTION 303 OF THE ROAD AND BRIDGE SPECIFICATIONS.
5. WHEN TWO SEPARATE SECTIONS OF GEOTEXTILE FABRIC ADJOIN EACH OTHER, THEY SHALL OVERLAP BY 6" AND BE DOUBLE FOLDED.
6. GEOTEXTILE FABRIC SHALL BE FASTENED SECURELY TO THE POSTS (TYPE A & B) AND WIRE FENCE (TYPE B ONLY). THE ATTACHMENTS TO THE WIRE FENCE SHALL BE MADE WITH TIES SPACED EVERY 24" HORIZONTALLY AT BOTH THE TOP AND VERTICAL MIDPOINT OF THE GEOTEXTILE FABRIC.
7. WIRE FENCE (TYPE B ONLY) SHALL BE FASTENED SECURELY TO THE FENCE POSTS WITH WIRE TIES AND EMBEDDED A MINIMUM OF 2" IN THE GROUND.
8. WIRE FENCE (TYPE B ONLY) SHALL BE A MINIMUM OF 14 GAUGE WELDED WIRE WITH A MESH SPACING OF 2" BY 4". ALTERNATIVE MESH SPACING MAY BE APPROVED BY THE ENGINEER, BUT MUST BE NO MORE THAN 6" BY 6".
9. FOR AREAS REQUIRING TYPE B SILT FENCE, A MINIMUM LENGTH OF 100 LINEAR FEET SHALL BE INSTALLED.
10. AS AN ALTERNATIVE TO UTILIZING TYPE B SILT FENCE, TWO ROWS OF TYPE A SILT FENCE MAY BE PLACED PARALLEL TO EACH OTHER WITH 3' TO 5' BETWEEN THE TWO ROWS. THIS OPTION MAY BE USED AT ALL LOCATIONS SPECIFYING TYPE B SILT FENCE UNLESS OTHERWISE PROHIBITED BY THE PLANS. SEE DETAIL ON SHEET 3 (BOTTOM RIGHT).
11. MATERIALS FOR ALL SILT FENCE SHALL CONFORM TO THE REQUIREMENTS OF SECTION 242 OF THE VDOT ROAD & BRIDGE SPECIFICATIONS.

SPECIFICATION REFERENCE

107
242
245
303

A COPY OF THE ORIGINAL SEALED AND SIGNED DRAWING IS ON FILE IN THE CENTRAL OFFICE.

TEMPORARY SILT BARRIERS
SILT FENCE (TYPE A & B) AND BRUSH BARRIER

VIRGINIA DEPARTMENT OF TRANSPORTATION

VDOT

ROAD AND BRIDGE STANDARDS

REVISION DATE

08/14

SHEET 1 OF 4

113.07

SILT FENCE TYPE A

SEE SHEET 1 FOR NOTES

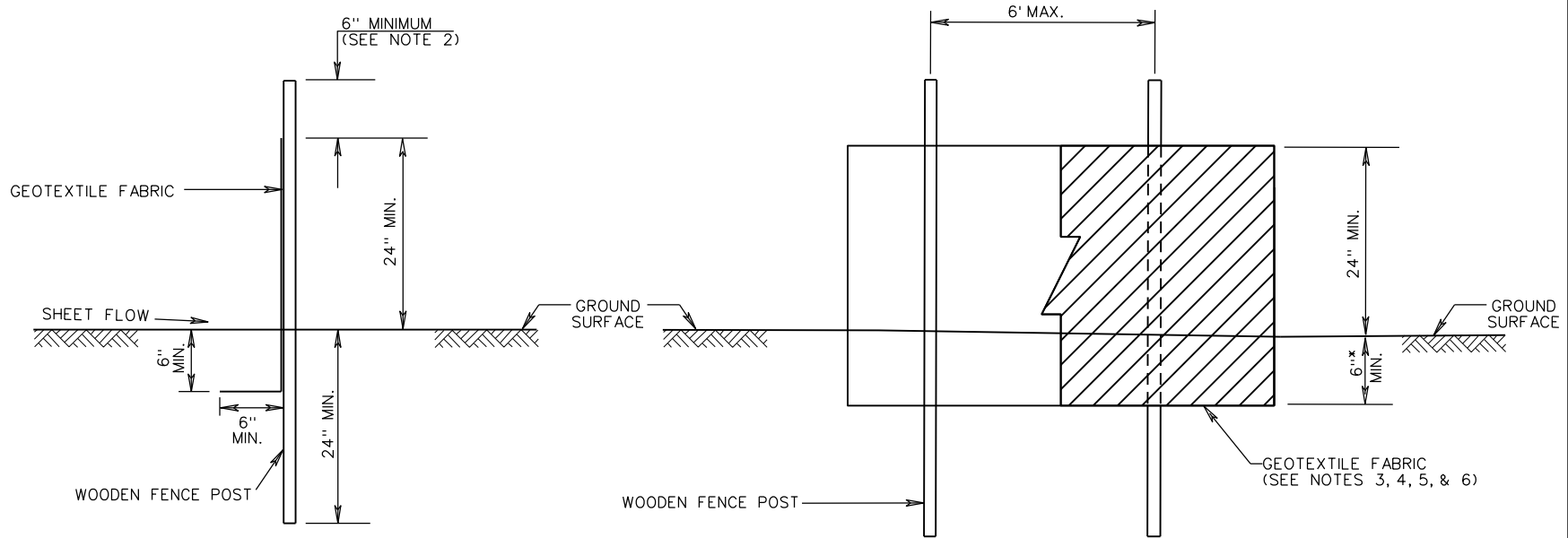

SECTION VIEW

PROFILE VIEW

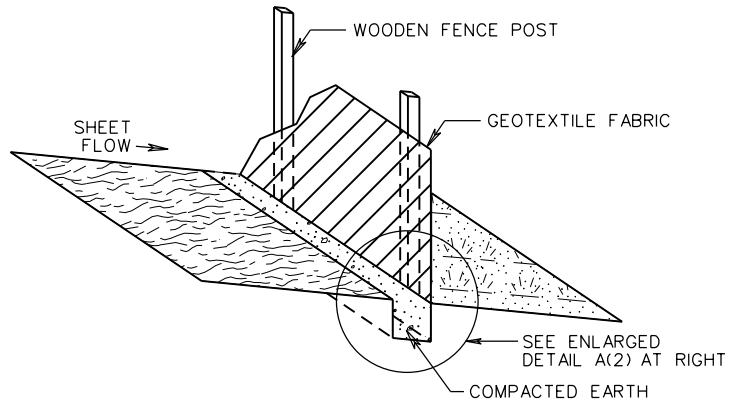

DETAIL A(1)

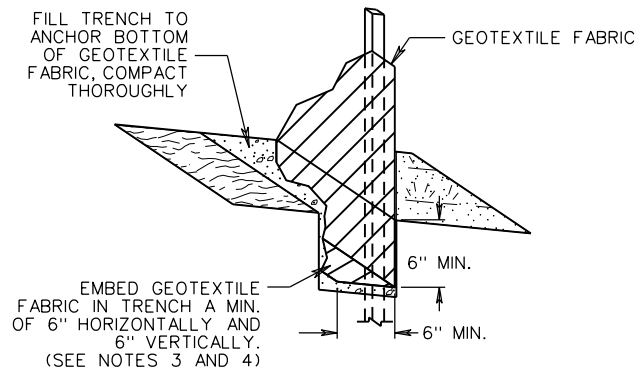

DETAIL A(2)



ROAD AND BRIDGE STANDARDS

A COPY OF THE ORIGINAL SEALED AND SIGNED DRAWING IS ON FILE IN THE CENTRAL OFFICE.

TEMPORARY SILT BARRIERS
SILT FENCE (TYPE A & B) AND BRUSH BARRIER

SPECIFICATION REFERENCE

SHEET 2 OF 4

REVISION DATE

107
242
245
303

113.07A

08/14

VIRGINIA DEPARTMENT OF TRANSPORTATION

SILT FENCE TYPE B

SEE SHEET 1 FOR NOTES

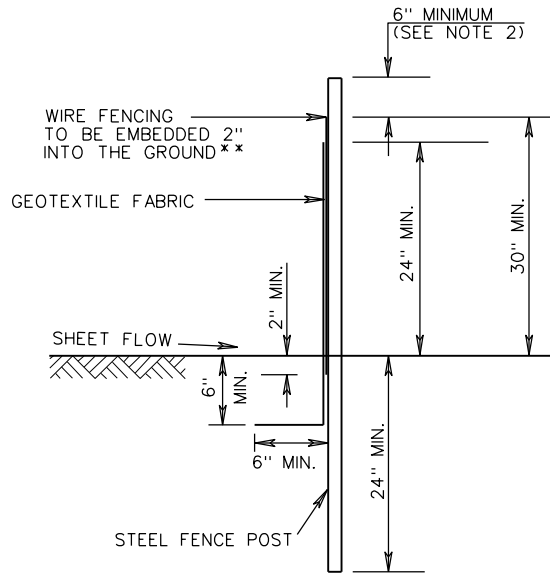

SECTION VIEW

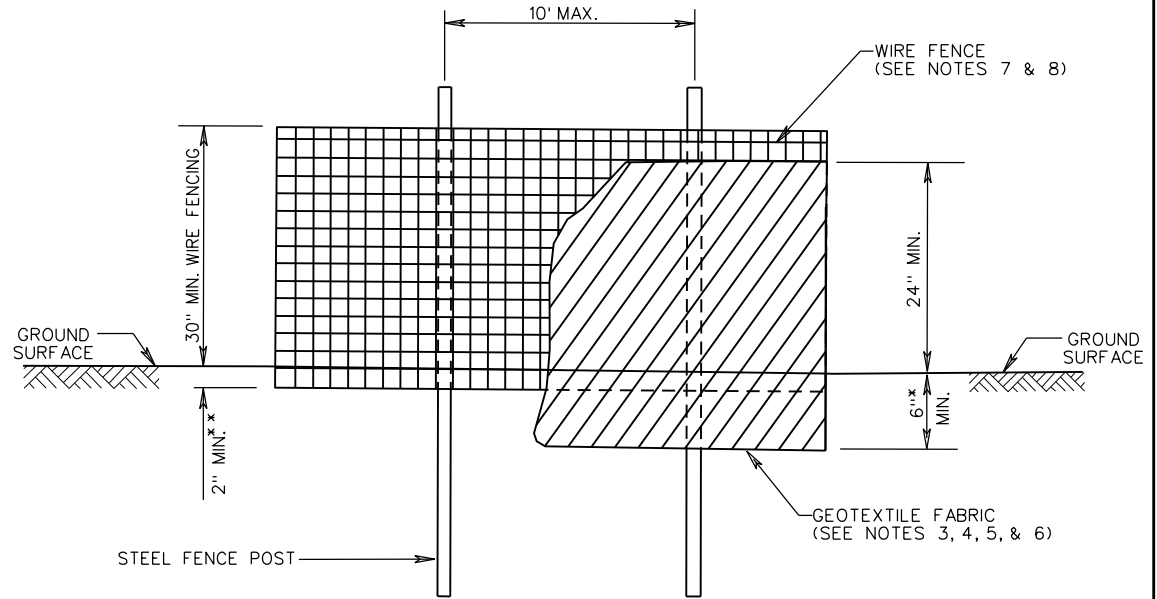

PROFILE VIEW

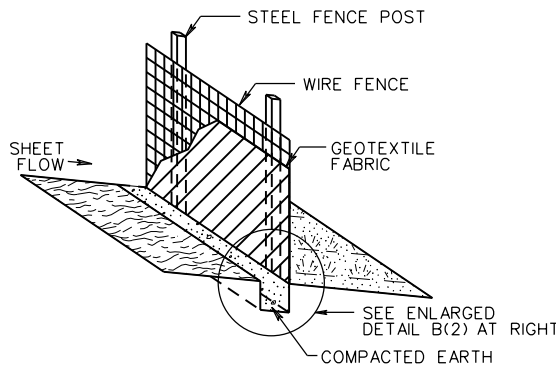

DETAIL B(1)

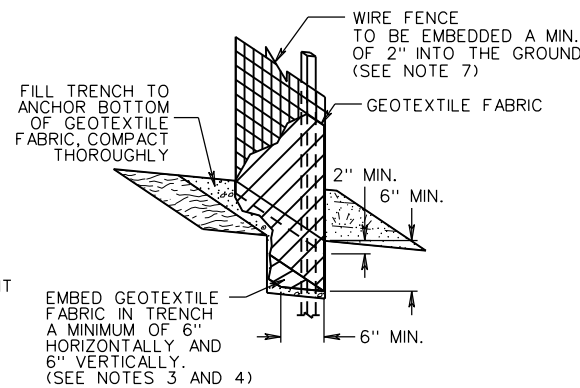

DETAIL B(2)

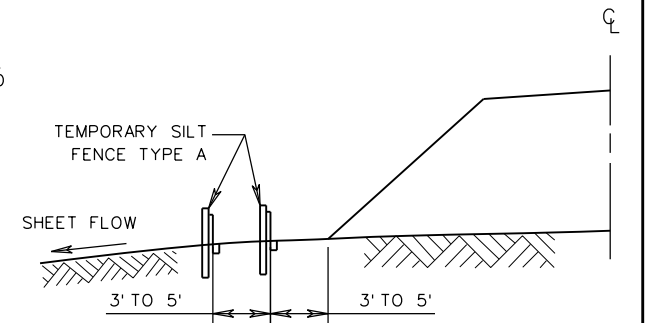

ALTERNATIVE SILT FENCE TYPE B
(SEE NOTE 10)

SPECIFICATION REFERENCE

107
242
245
303

A COPY OF THE ORIGINAL SEALED AND SIGNED DRAWING IS ON FILE IN THE CENTRAL OFFICE.

TEMPORARY SILT BARRIERS

SILT FENCE (TYPE A & B) AND BRUSH BARRIER

VIRGINIA DEPARTMENT OF TRANSPORTATION

VDOT

ROAD AND BRIDGE STANDARDS

REVISION DATE

08/14

SHEET 3 OF 4

113.07B

SILT BARRIERS
TYPICAL DETAIL FOR BRUSH BARRIER
 (TO BE USED AT ALL APPLICABLE LOCATIONS)

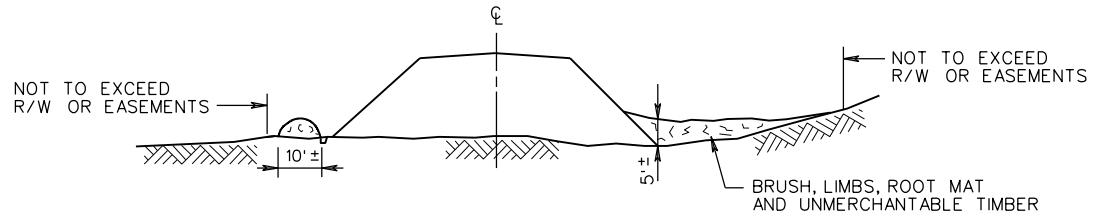
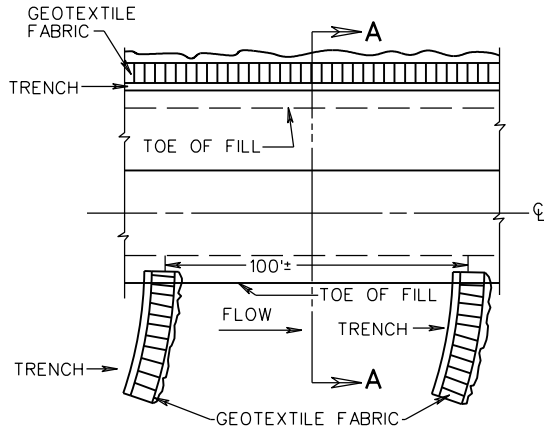

SECTION A-A

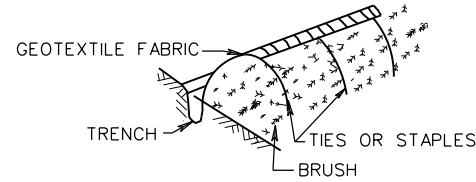

BACK ISOMETRIC

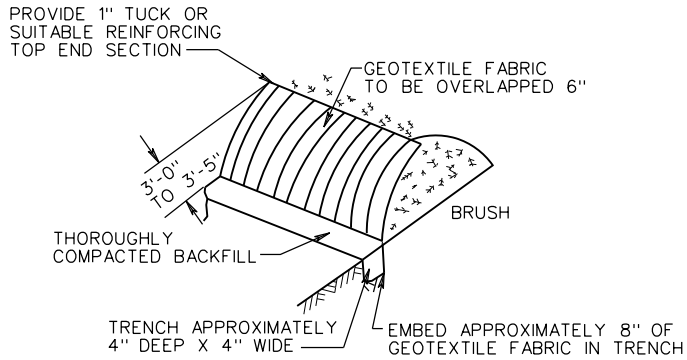

FRONT ISOMETRIC

NOTES:

- BRUSH BARRIERS SHALL BE CONSTRUCTED AT LOCATION SHOWN ON THE PLANS OR AS DIRECTED BY THE ENGINEER. BRUSH SHALL BE PILED AGAINST EXISTING TREES TO PREVENT MOVEMENT OF BARRIER. BRUSH SHALL BE PILED AS TIGHTLY AS POSSIBLE AND WEIGHTED DOWN BY UNMERCHANTABLE LOGS.
- GEOTEXTILE FABRIC CONFORMING TO THE ROAD AND BRIDGE SPECIFICATIONS SHALL BE INSTALLED AS DETAILED ABOVE. GEOTEXTILE FABRIC MAY ALSO BE ATTACHED TO EXISTING FENCES WHEN SPECIFIED ON THE PLANS OR DIRECTED BY THE ENGINEER.
- NO BRUSH WILL BE DESTROYED OR REMOVED FROM THE PROJECT UNTIL ALL BRUSH SILT BARRIERS ARE IN PLACE AND HAVE BEEN INSPECTED AND APPROVED BY THE ENGINEER.
- DIMENSIONS SHOWN ARE APPROXIMATE ONLY.



ROAD AND BRIDGE STANDARDS

SHEET 4 OF 4

REVISION DATE

113.08

08/14

TEMPORARY SILT BARRIERS
SILT FENCE (TYPE A & B), AND BRUSH BARRIER

VIRGINIA DEPARTMENT OF TRANSPORTATION

SPECIFICATION
 REFERENCE

107
 303

INLET PROTECTION (TYPE A)

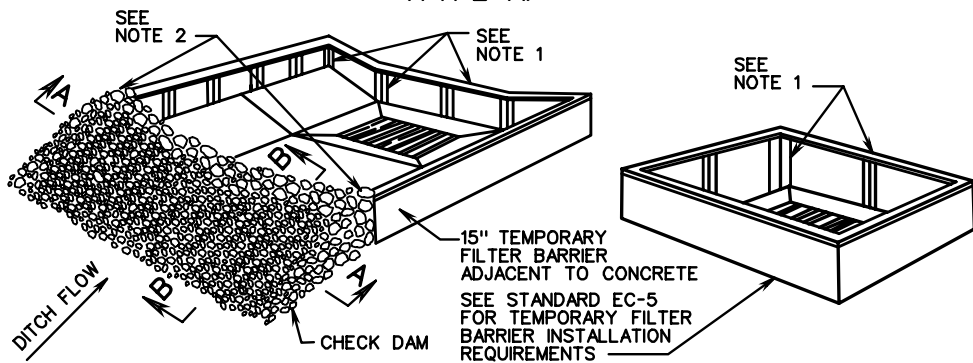

TYPICAL TREATMENT FOR DROP INLET WITH CONCRETE GUTTER

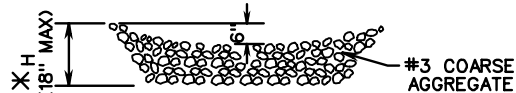

SECTION A-A

* IF CHECK DAM IS LOCATED INSIDE CLEAR ZONE AND ADJACENT TO A TRAVELWAY, SLOPE FACING ON COMING TRAFFIC IS TO BE 6:1 AND MAXIMUM H IS TO BE 12".

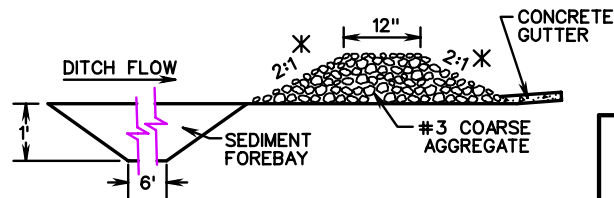

SECTION B-B

NOTES

1. POSTS AND TOP RAIL SHALL BE A NOMINAL 2 1/2" X 2 1/2" OR A 3" DIA. NO. 2 SOUTHERN PINE, A NOMINAL 2" X 2" OAK, OR STEEL HAVING A MIN. WEIGHT OF 1.25 LBS. PER LINEAR FOOT AND A MIN. LENGTH OF 5' FOR TEMPORARY SILT FENCES.
2. END OF FILTER BARRIER TO BE EMBEDDED INTO AGGREGATE.
3. IF A DROP INLET IS LOCATED IN A SAG IN THE DITCH GRADE, A CHECK DAM IS REQUIRED FOR EACH SIDE OF THE INLET THAT RECEIVES DITCH FLOW.
4. WHERE DRAINAGE AREAS EXCEED ONE ACRE OR DITCH GRADE EXCEEDS 3%, A TEMPORARY SEDIMENT FOREBAY SHALL BE INSTALLED WITH MINIMUM DIMENSIONS OF 12" DEPTH, 2' WIDTH AND 6' LENGTH.

TYPICAL TREATMENT FOR DROP INLET WITHOUT CONCRETE GUTTER

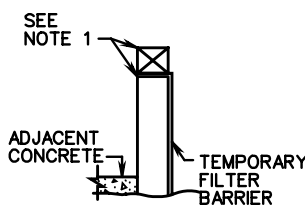

INLET PROTECTION (TYPE B)

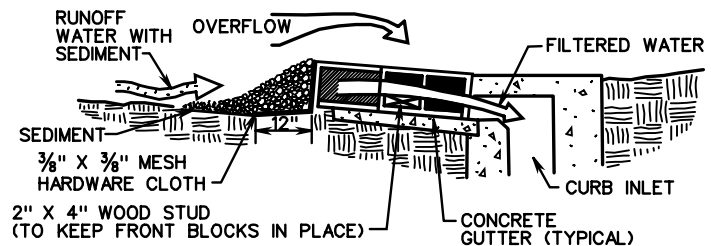
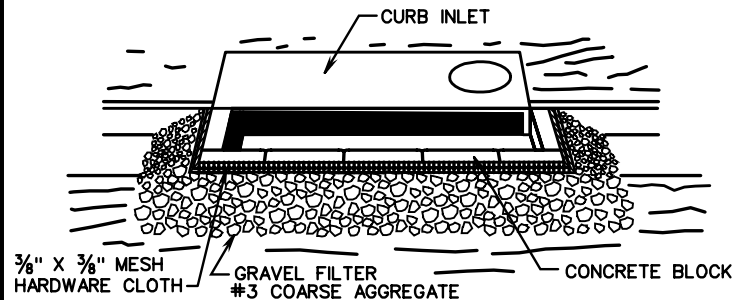

SECTION VIEW

SPECIFIC APPLICATION

THIS METHOD OF INLET PROTECTION IS APPLICABLE AT CURB INLETS WHERE AN OVERFLOW CAPABILITY IS NECESSARY TO PREVENT EXCESSIVE PONDING IN FRONT OF THE STRUCTURE.

NOTE:

GEOTEXTILE PRODUCTS DESIGNED TO BE INSERTED INTO GRATED DROP INLETS OR DESIGNED TO COVER THE SLOTS OF SLOT DROP INLETS, THAT HAVE BEEN APPROVED FOR USE ON VDOT PROJECTS AND ARE FOUND ON VDOT'S SPEL LIST, MAY BE SUBSTITUTED FOR THE DROP INLET PROTECTION DEVICES DETAILED HEREON.

SPECIFICATION REFERENCE

- 107
- 242
- 303

INLET PROTECTION (TYPE A AND B)

VIRGINIA DEPARTMENT OF TRANSPORTATION

VDOT

ROAD AND BRIDGE STANDARDS

REVISION DATE

SHEET 1 OF 2

113.09

TYPICAL DETAIL FOR INSTALLATION OF TEMPORARY FILTER BARRIER/SILT FENCE/CHECK DAM AT CULVERT

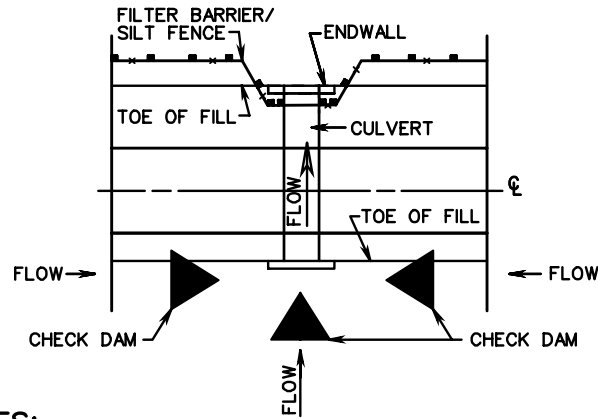

NOTES:

1. IF ANY PORTION OF FILL IS GREATER THAN 5', SILT FENCE IS REQUIRED. IF FILL HEIGHT IS LESS THAN 5', FILTER BARRIER IS REQUIRED.
2. ROCK CHECK DAM IS TO BE CONSTRUCTED IN ACCORDANCE WITH THE ROAD AND BRIDGE SPECIFICATIONS, AND STANDARD EC-4.
3. FILTER BARRIER/SILT FENCE IS TO BE INSTALLED IN ACCORDANCE WITH THE ROAD AND BRIDGE SPECIFICATIONS, AND STANDARD EC-5.

* INSTALLATION DETAIL ONLY - ROCK CHECK DAMS, FILTER BARRIER, AND SILT FENCE TO BE PAID FOR IN ACCORDANCE WITH THE ROAD AND BRIDGE SPECIFICATIONS.



ROAD AND BRIDGE STANDARDS

SHEET 2 OF 2

REVISION DATE

113.10

INLET PROTECTION
(TYPE C)

VIRGINIA DEPARTMENT OF TRANSPORTATION

SPECIFICATION
REFERENCE

107
242
303

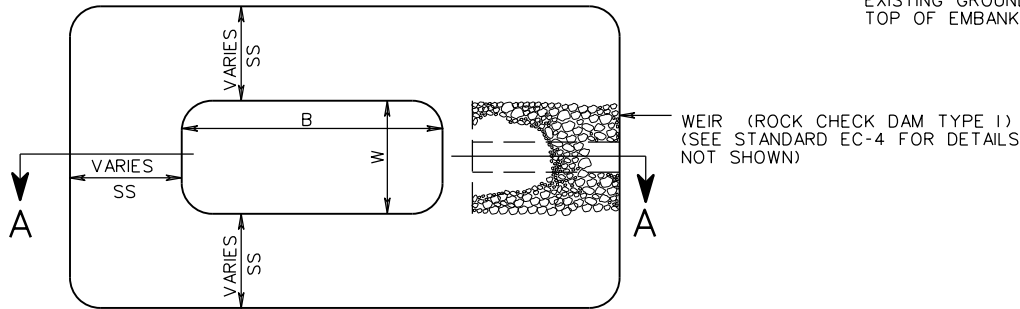

PLAN VIEW OF TEMPORARY SEDIMENT TRAP

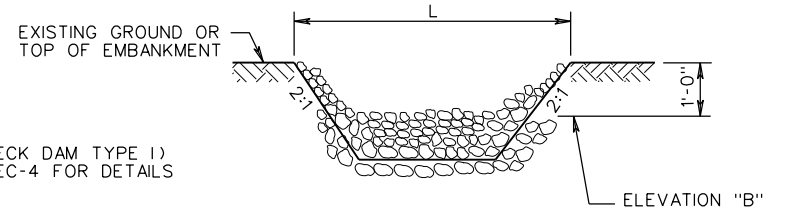

TYPICAL SECTION THRU WEIR
(ROCK CHECK DAM TYPE 1)

NOTES:

1. CHECK DAM IS SHOWN FOR ILLUSTRATION ONLY AND IS NOT INCLUDED IN PAYMENT FOR SEDIMENT TRAP.
2. THE SEDIMENT STORAGE VOLUME SHALL BE 134 CUBIC YARDS/ACRE OF TOTAL CONTRIBUTING DRAINAGE AREA AND SHALL CONSIST OF HALF IN THE FORM OF WET STORAGE AND HALF IN THE FORM OF DRY STORAGE.
3. SEE PLANS FOR DIMENSIONS AND ELEVATIONS.

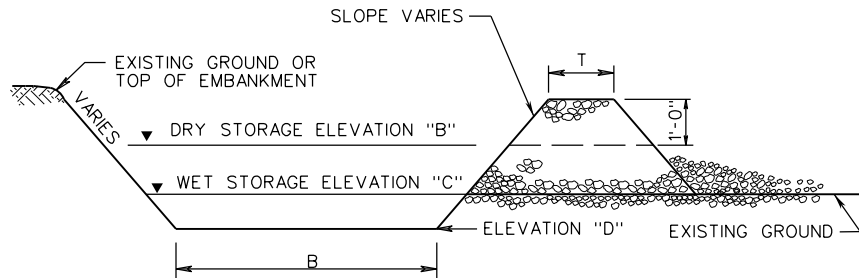

TYPICAL SECTION (A-A) THRU
TEMPORARY SEDIMENT TRAP

SPECIFICATION REFERENCE
107 303

TYPICAL SEDIMENT TRAP

VIRGINIA DEPARTMENT OF TRANSPORTATION

VDOT	
ROAD AND BRIDGE STANDARDS	
REVISION DATE	SHEET 1 OF 1
01/13	113.11

TYPICAL DEWATERING BASIN

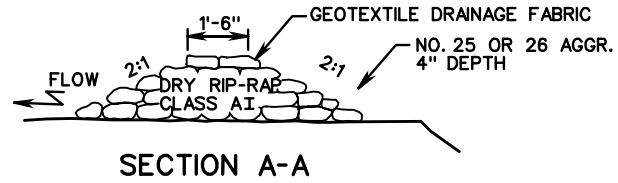
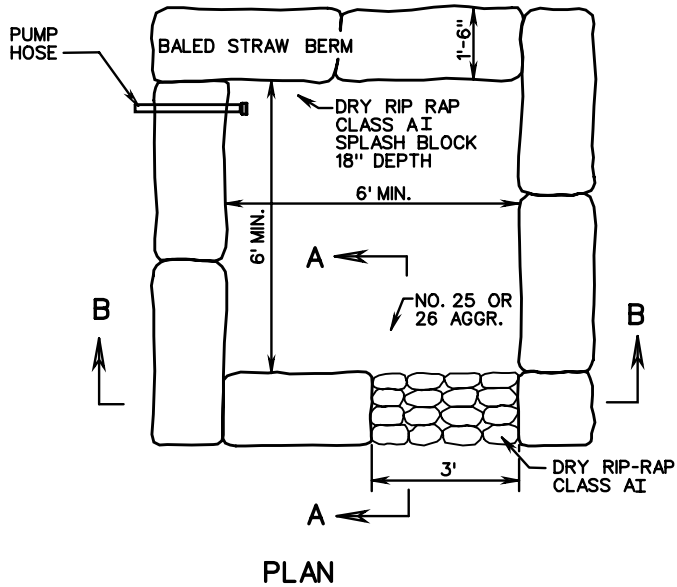

* GEOTEXTILE DRAINAGE FABRIC TO COVER INSIDE FACE OF BALED STRAW BERM.

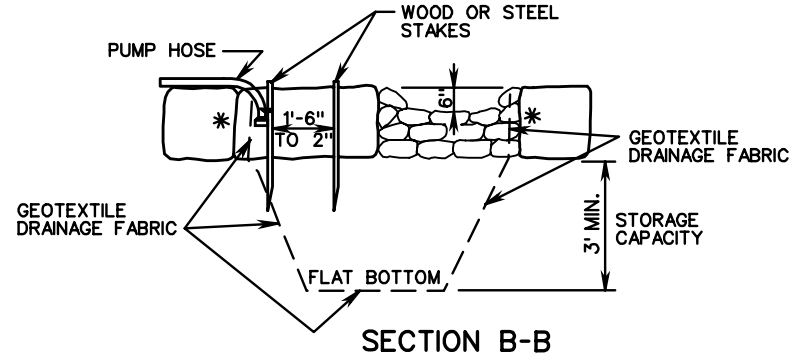

NOTES:

1. DEWATERING BASIN SIZE SHALL BE DETERMINED BY THE FORMULA $16 \times \text{GAL./MIN. OF PUMP} = \text{CU. FT. OF STORAGE CAPACITY}$.
2. THIS WORK SHALL CONSIST OF THE CONSTRUCTION OF A DEWATERING BASIN FOR THE PURPOSE OF RECEIVING SEDIMENT-LADENED WATER PUMPED FROM A CONSTRUCTION SITE TO ALLOW FOR FILTRATION BEFORE IT REENTERS THE WATERWAY. PUMPING INTO THESE BASINS SHALL CEASE WHEN THE FLOW FROM THE BASIN BECOMES SEDIMENT-LADENED.
3. SURFACE WATER FLOW SHALL BE DIVERTED AROUND THIS DEVICE.
4. THE OUTFALL FROM THE BASIN(S) SHALL HAVE A STABILIZED CONVEYANCE TO RECEIVING WATERS.
5. ONCE THE DEWATERING BASIN BECOMES FILLED TO HALF OF THE STORAGE CAPACITY, ACCUMULATED SEDIMENT SHALL BE REMOVED AND DISPOSED OF IN AN APPROVED DISPOSAL AREA OUTSIDE OF THE 100-YEAR FLOODPLAIN UNLESS OTHERWISE APPROVED ON THE PLANS.
6. SEDIMENT CONTROL DEVICES ARE TO REMAIN IN PLACE UNTIL ALL DISTURBED AREAS ARE STABILIZED AND THE ENGINEER APPROVES THEIR REMOVAL. GROUND CONTOURS SHALL BE RETURNED TO THEIR ORIGINAL CONDITION UNLESS SPECIFICALLY APPROVED OTHERWISE BY THE ENGINEER.
7. SYNTHETIC PRODUCTS THAT HAVE BEEN APPROVED FOR USE ON VDOT PROJECTS AND FOUND ON VDOT'S SPEL LIST MAY BE USED IN LIEU OF THIS DESIGN. HOWEVER, VDOT WILL ONLY COMPENSATE THE CONTRACTOR UP TO THE BID PRICE PER EACH AT EACH SITE.

TYPICAL SYNTHETIC PRODUCT

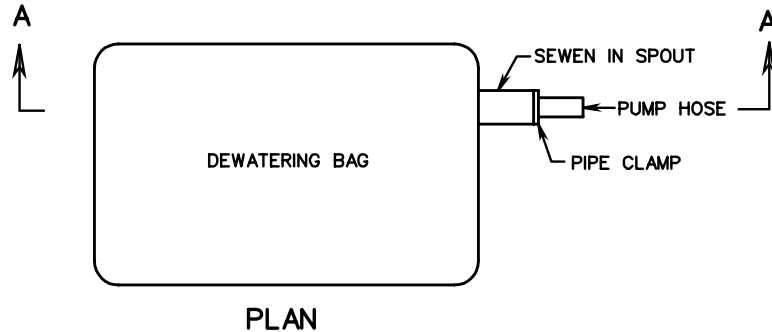
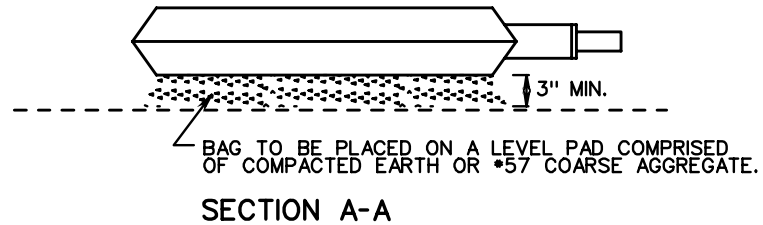

ROAD AND BRIDGE STANDARDS

SHEET 1 OF 1

REVISION DATE

113.12

DEWATERING BASIN

VIRGINIA DEPARTMENT OF TRANSPORTATION

SPECIFICATION REFERENCE

107
303

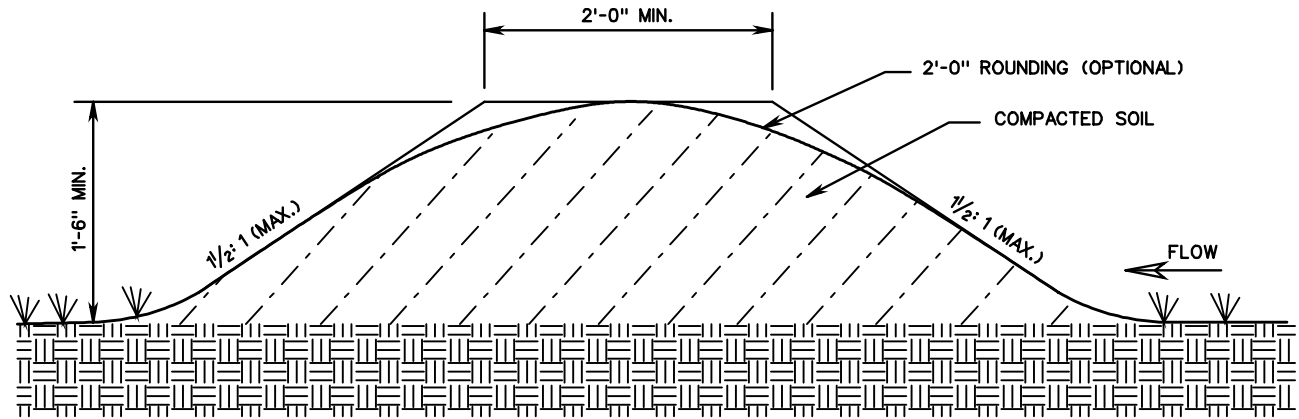

TEMPORARY DIVERSION DIKE

NOTE:

1. THE CHANNEL CREATED BEHIND THE DIKE SHALL HAVE A POSITIVE GRADE TO A STABILIZED OUTLET. THE CHANNEL SHALL BE STABILIZED, AS NECESSARY, TO PREVENT EROSION.
2. TEMPORARY DIVERSION DIKE WILL BE MEASURED AND PAID FOR IN ACCORDANCE WITH SECTION 303 OF THE SPECIFICATIONS.

SPECIFICATION REFERENCE	<h2 style="margin: 0;">TEMPORARY DIVERSION DIKE</h2>	ROAD AND BRIDGE STANDARDS				
303	VIRGINIA DEPARTMENT OF TRANSPORTATION	<table border="1" style="width: 100%; border-collapse: collapse;"> <tr> <td style="width: 50%;">REVISION DATE</td> <td style="width: 50%;">SHEET 1 OF 1</td> </tr> <tr> <td colspan="2" style="text-align: center;">113.13</td> </tr> </table>	REVISION DATE	SHEET 1 OF 1	113.13	
REVISION DATE	SHEET 1 OF 1					
113.13						

TEMPORARY BERM & SLOPE DRAIN

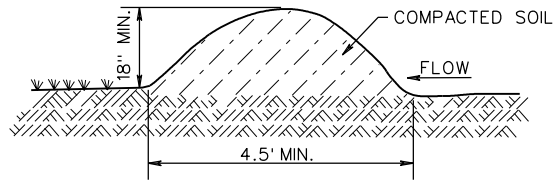
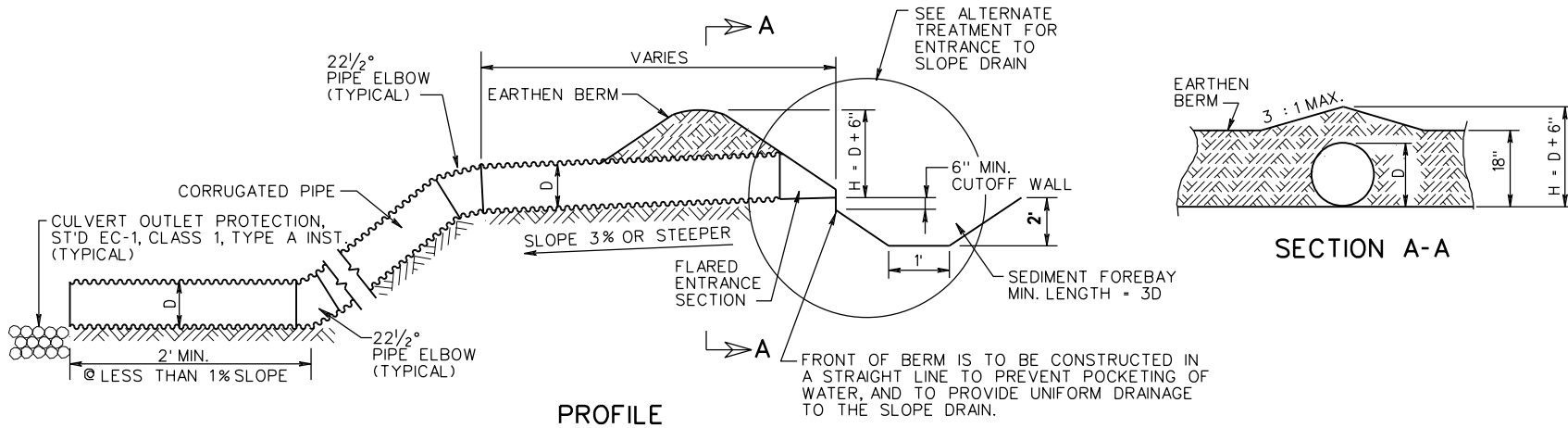

EARTHEN BERM SHALL BE INSTALLED IN ACCORDANCE WITH THE PLANS AND SPECIFICATIONS OR AS DIRECTED BY THE ENGINEER.

SIZE OF SLOPE DRAIN	
MAXIMUM DRAINAGE AREA (ACRES)	MINIMUM PIPE DIAMETER, D (IN.)
0.5	12
1.5	18
2.5	21
3.0	24

NOTES

1. SLOPE DRAIN SHALL BE SECURELY STAKED TO THE SLOPE, AT 10' (OR LESS) INTERVALS.
2. THE SLOPE DRAIN SECTIONS SHALL BE SECURELY FASTENED TOGETHER AND HAVE WATER TIGHT FITTINGS.

ALTERNATE ENTRANCE TREATMENT

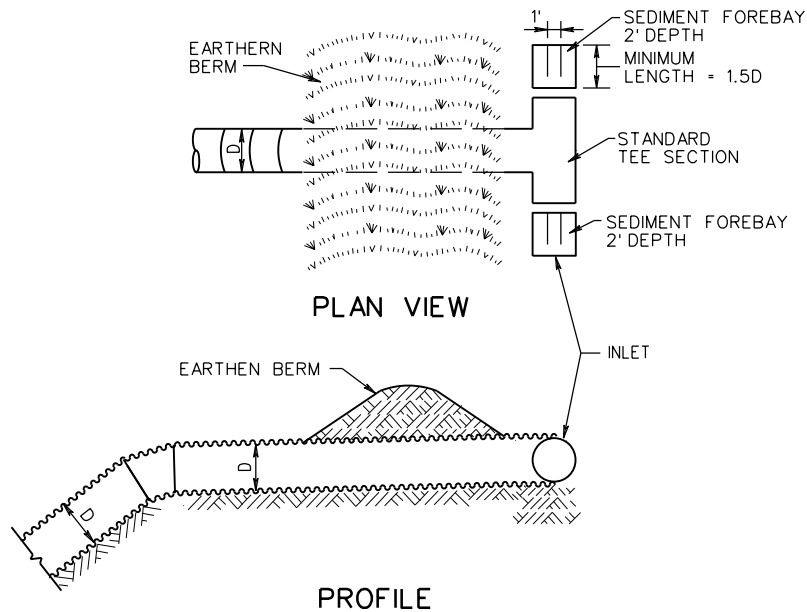

ROAD AND BRIDGE STANDARDS

TEMPORARY BERM & SLOPE DRAIN

SPECIFICATION REFERENCE

SHEET 1 OF 1

REVISION DATE

VIRGINIA DEPARTMENT OF TRANSPORTATION

113.14

01/13

107
303

MINIMUM REQUIREMENTS FOR STABILIZED CONSTRUCTION ENTRANCE

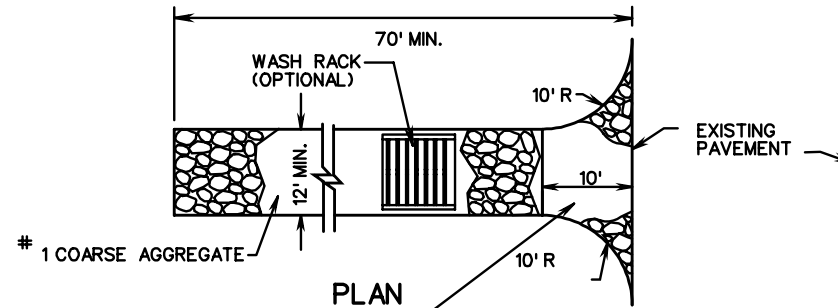

6" MINIMUM DEPTH #1 COARSE AGGREGATE, WITH MINIMUM 10' CLOSEST TO ROADWAY CAPPED WITH 4" MINIMUM DEPTH #68 OR #78 AGGREGATE, AS DIRECTED BY THE ENGINEER.

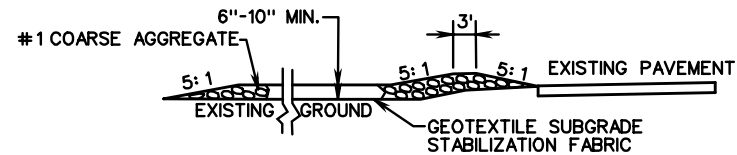

PROFILE

1. SURFACE WATER SHALL BE PIPED UNDER THE CONSTRUCTION ENTRANCE. IF PIPING IS IMPRACTICAL, A MOUNTABLE BERM WITH 5:1 SLOPES WILL BE PERMITTED.
2. THE ENTRANCE SHALL BE MAINTAINED IN A CONDITION WHICH WILL PREVENT TRACKING OR FLOWING OF SEDIMENT ONTO PUBLIC RIGHT OF WAY. THIS MAY REQUIRE PERIODIC TOP DRESSING WITH ADDITIONAL STONE AS CONDITIONS DEMAND AND REPAIR AND/OR CLEANOUT OF ANY MEASURES USED TO TRAP SEDIMENT. ALL SEDIMENT SPILLED, DROPPED, WASHED OR TRACKED ONTO PUBLIC RIGHT OF WAY SHALL BE REMOVED IMMEDIATELY.
3. WHEELS SHALL BE CLEANED TO REMOVE SEDIMENT PRIOR TO ENTRANCE ONTO PUBLIC RIGHT OF WAY. WHEN WASHING IS REQUIRED, IT SHALL BE DONE ON AN AREA STABILIZED WITH STONE AND WHICH DRAINS INTO AN APPROVED SEDIMENT TRAPPING DEVICE.
4. PERIODIC INSPECTION AND NEEDED MAINTENANCE SHALL BE PROVIDED AFTER HEAVY USE AND EACH RAIN.

SPECIFICATION REFERENCE

107
303

STABILIZED CONSTRUCTION ENTRANCE

VIRGINIA DEPARTMENT OF TRANSPORTATION

VDOT

ROAD AND BRIDGE STANDARDS

REVISION DATE

SHEET 1 OF 1

113.15

TYPICAL SECTION
TEMPORARY DIVERSION CHANNEL
AND ACCEPTABLE LININGS

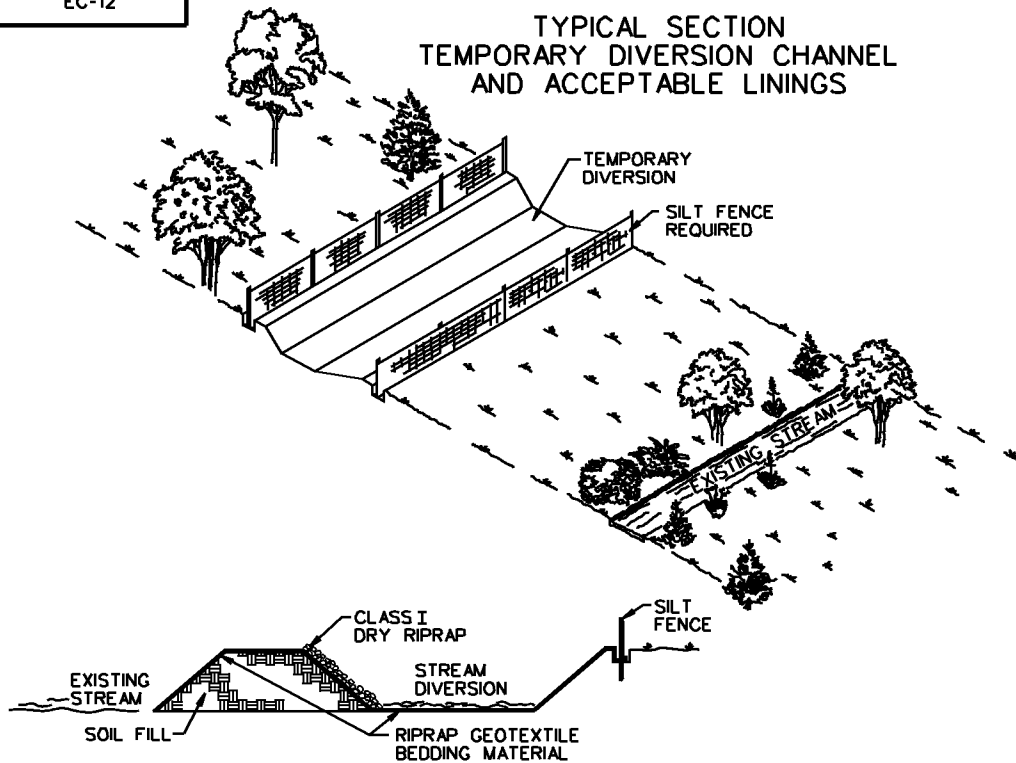

DAM DETAIL

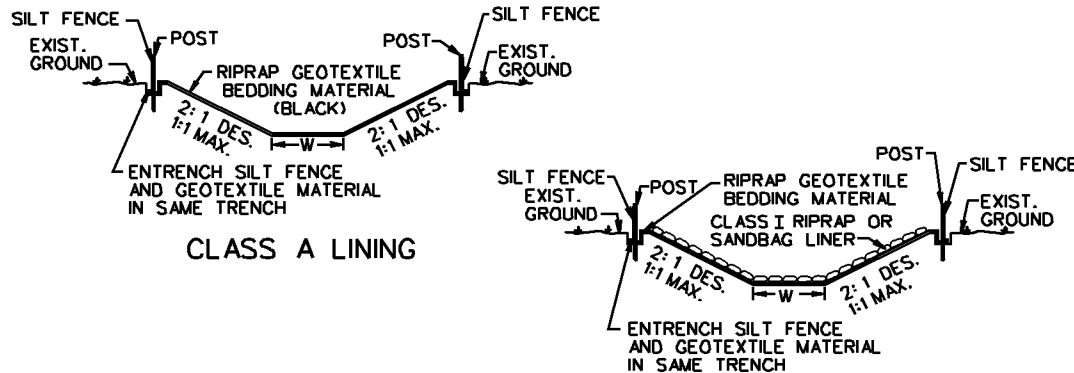

CLASS B LINING

BOTTOM WIDTH OF TEMPORARY DIVERSION CHANNEL SHALL APPROXIMATE THE BOTTOM WIDTH OF THE NATURAL STREAM CHANNEL.

STREAM DIVERSION
GENERAL NOTES

SLOPES

MAXIMUM STEEPNESS OF SIDE SLOPES SHALL BE 1:1. DEPTH AND GRADE MAY BE VARIABLE, DEPENDENT ON SITE CONDITIONS, BUT SHALL BE SUFFICIENT TO ENSURE CONTINUOUS FLOW OF WATER IN THE DIVERSION.

EXCAVATION

NO EXCAVATED MATERIAL SHALL BE STORED OR STOCKPILED NEXT TO THE DIVERSION OR IN SUCH A MANNER THAT SILTATION OF THE STREAM COULD OCCUR.

PIPE CULVERTS

PIPE CULVERT(S) MAY BE USED TO DIVERT A STREAM PROVIDED THEY ARE PROPERLY SIZED TO SAFELY CARRY THE FLOW OF A TWO YEAR STORM EVENT. UNDERSIZED PIPES SHALL BE USED FOR NO LONGER THAN 72 HOURS PROVIDED LESS THAN 50% THREAT OF RAIN CAN BE REASONABLY EXPECTED WITHIN THAT TIME PERIOD AND THEY ARE APPROVED BY THE ENGINEER.

WHEN THE CONTRACTOR USES PIPE CULVERTS IN LIEU OF THE DIVERSION CHANNEL OR A PORTION OF THE CHANNEL, PAYMENT WILL BE MADE BASED ON THE PRICE BID FOR THE QUANTITIES SHOWN ON THE PLANS FOR TEMPORARY DIVERSION CHANNEL EXCAVATION AND TEMPORARY DIVERSION CHANNEL LINING CLASS SPECIFIED.

LINING

THE CONTRACTOR SHALL HAVE THE OPTION OF USING A HIGHER CLASS OF LINING THAN THAT SPECIFIED ON THE PLANS. NO ADDITIONAL COMPENSATION WILL BE ALLOWED FOR USING THE HIGHER CLASS.

STREAM DIVERSION LINERS SHALL BE SECURED AT THE UPSTREAM AND DOWNSTREAM SIDES WITH NON-ERODIBLE WEIGHTS SUCH AS EROSION CONTROL STONE. THESE WEIGHTS SHALL ALLOW NORMAL FLOW OF THE STREAM. SOIL SHALL NOT BE MIXED IN WITH STREAM DIVERSION WEIGHTS. WEIGHTS MAY ALSO BE NEEDED ALONG THE STREAM DIVERSION'S LENGTH.

STREAM DIVERSION LINERS SHALL BE ENTRENCHED AT THE TOP OF THE DIVERSION SLOPES (SLOPE BREAKS) WITH A LINE OF SILT FENCE.

PROTECTIVE COVERING (EC-2) STAPLES OR NON-ERODIBLE WEIGHTS SHALL BE USED AS NECESSARY TO ANCHOR STREAM DIVERSION LINERS TO THE SIDE SLOPES OF THE DIVERSION. WOODEN STAKES SHALL NOT BE USED ON THE DIVERSION'S BOTTOM OR SIDE SLOPES.

STREAM DIVERSION LINERS SHALL BE OVERLAPPED WHEN A SINGLE OR CONTINUOUS LINER IS NOT AVAILABLE OR IS IMPRACTICAL. OVERLAPS SHALL BE PLACED SUCH THAT CONTINUOUS FLOW OF THE STREAM IS MAINTAINED. AN UPSTREAM SECTION SHALL OVERLAP A DOWNSTREAM SECTION BY A MINIMUM OF 18". OVERLAPS ALONG THE CROSS SECTION SHALL BE MADE SUCH THAT A LINER IS PLACED IN THE STREAM DIVERSION BOTTOM FIRST AND ADDITIONAL PIECES OF LINER ON THE SLOPES OVERLAP THE BOTTOM PIECE BY A MINIMUM OF 18".

GENERAL

THE DOWNSTREAM PLUG SHALL BE REMOVED PRIOR TO THE UPSTREAM PLUG WHEN A STREAM DIVERSION IS USED FOR THE TRANSPORT OF WATER.

NON-ERODIBLE MATERIALS, INCLUDING BUT NOT LIMITED TO, EROSION CONTROL STONE, CONCRETE BARRIERS, SANDBAGS, PLYWOOD, OR SHEET PILING SHALL BE USED BOTH TO DIVERT THE STREAMS AWAY FROM THEIR ORIGINAL CHANNELS AND TO PREVENT OR REDUCE WATER BACKUP INTO A CONSTRUCTION AREA.

STREAMS MAY BE DIVERTED THROUGH AN EXISTING OR INCOMPLETE STRUCTURE PROVIDED THEY WILL NOT RE-ENTER A DISTURBED AREA, COME INTO CONTACT WITH WET CONCRETE, AND/OR BECOME PARTIALLY OR WHOLLY IMPOUNDED, SILTED, OR OTHERWISE CONTAMINATED.

STREAMS MAY BE REDIVERTED UPON COMPLETION OF THE DRAINAGE STRUCTURE(S) FOR WHICH THE DIVERSION WAS BUILT. PRIOR TO REDIVERSION, ANY MATERIALS USED TO PREVENT WATER BACKUP INTO THE DOWNSTREAM END OF THE DRAINAGE STRUCTURE(S) SHALL BE REMOVED. THIS MATERIAL SHALL NOT BE PLACED IN THE DOWNSTREAM END OF THE DIVERSION UNTIL AFTER WATER HAS BEEN REDIVERTED TO THE DRAINAGE STRUCTURE(S). A STREAM SHALL BE REDIVERTED BY REMOVING ALL OF THE MATERIALS DAMMING THE UPSTREAM END OF THE DRAINAGE STRUCTURE(S) BEFORE PLACING IT IN THE UPSTREAM END OF THE STREAM DIVERSION. THE DIVERSION SHALL BE SEALED OFF AT THE DOWNSTREAM END AND THEN BACKFILLED.

ONCE STARTED, ANY WORK TO RELOCATE A STREAM (PLUGS) SHALL NOT BE DISCONTINUED UNTIL IT IS COMPLETED.

ANY DEVIATIONS TO THE ABOVE NOTED STREAM DIVERSION DESIGN, INSTALLATION, OR MAINTAINANCE SHALL BE APPROVED BY THE ENGINEER.



ROAD AND BRIDGE STANDARDS

SHEET 1 OF 1

REVISION DATE

113.16

4/09

TEMPORARY DIVERSION CHANNEL

VIRGINIA DEPARTMENT OF TRANSPORTATION

SPECIFICATION
REFERENCE

302

303

414

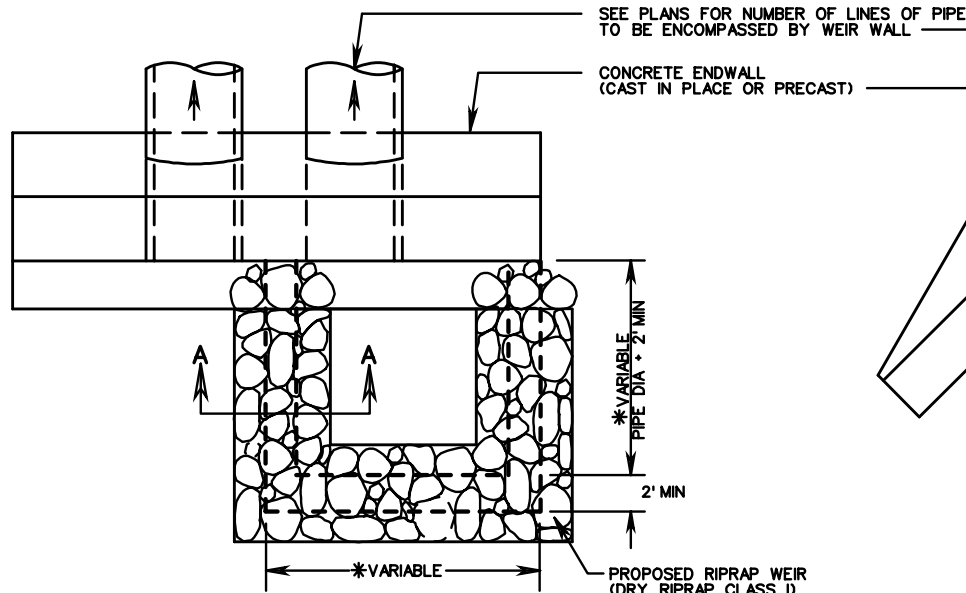

PLAN VIEW
(ENDWALL WITHOUT WINGS)

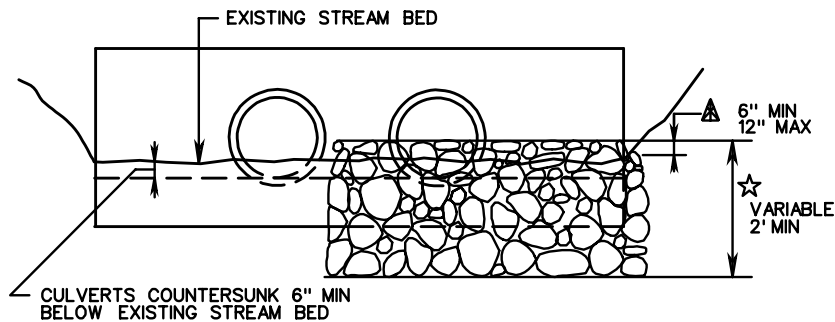

END VIEW

LEGEND

- Ⓐ 6' MINIMUM OR 1/2 P.
- * DIMENSION VARIES ACCORDING TO PIPE SIZE, SKEW AND ENDWALL DIMENSIONS
- ☆ DEPTH OF FOUNDATION TO BE VARIABLE ACCORDING TO SITE CONSTRAINTS OR AS DIRECTED BY THE ENGINEER
- ▲ THE PROPOSED HEIGHT OF THE RIPRAP WEIR, FROM THE EXISTING STREAM BED TO THE TOP OF WEIR, IS TO BE SPECIFIED ON THE ROADWAY PLANS. "X" DIMENSION (HEIGHT OF WEIR ABOVE STREAM BED) CAN BE A MINIMUM OF 6" OR ANY VARIABLE DIMENSION TO A MAXIMUM OF 12".

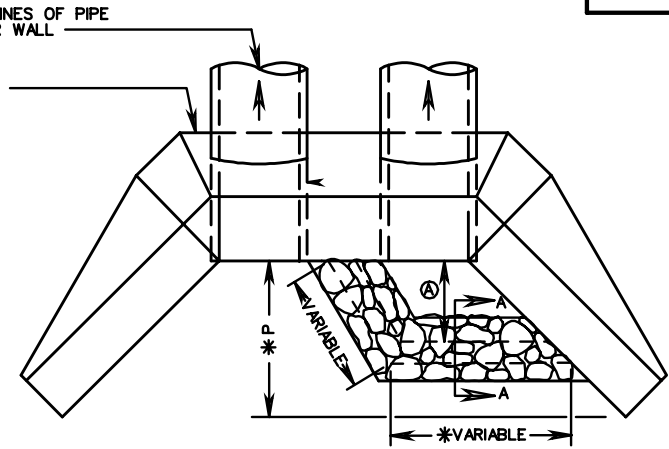

PLAN VIEW
(ENDWALL WITH WINGS)

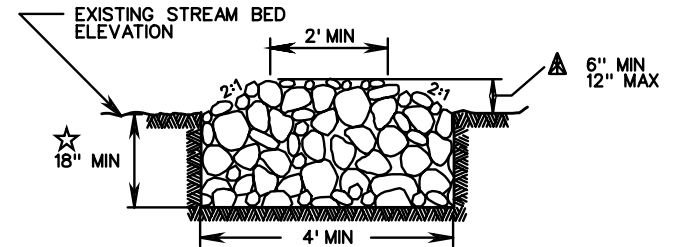

TYPICAL SECTION A-A

NOTES:

1. THE TOP WIDTH OF THE WEIR IS VARIABLE AND IS TO BE ADJUSTED AS NEEDED TO DIRECT THE LOW FLOW TO THE BARREL(S) DESIGNATED ON THE PLANS.
2. FOR SKEWED ENDWALLS, RIPRAP WEIR SIDES ARE TO BE CONSTRUCTED PARALLEL WITH PIPE SKEW.
3. REFER TO APPLICABLE ENDWALL STANDARD DRAWING FOR DIMENSIONS NOT SHOWN HEREIN
4. BASIS OF PAYMENT: TO BE PAID FOR AS SQ.YDS. OR TONS OF DRY RIPRAP CLASS I

SPECIFICATION
REFERENCE

107
303

RIPRAP WEIRS
LOW FLOW DIVERSION FOR MULTIPLE LINE CULVERT INSTALLATIONS

VIRGINIA DEPARTMENT OF TRANSPORTATION

VDOT

ROAD AND BRIDGE STANDARDS

REVISION DATE

SHEET 1 OF 1

113.17

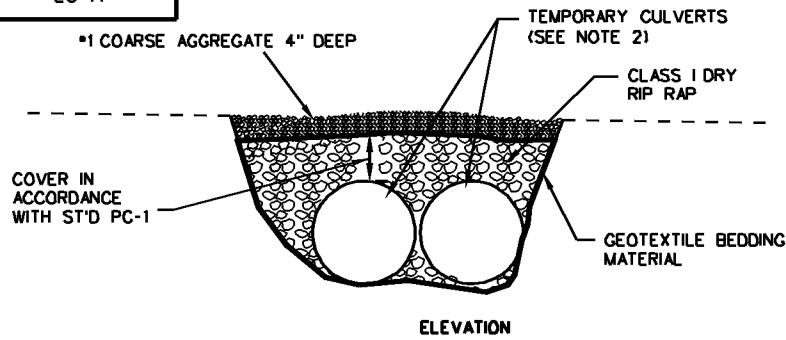

ELEVATION

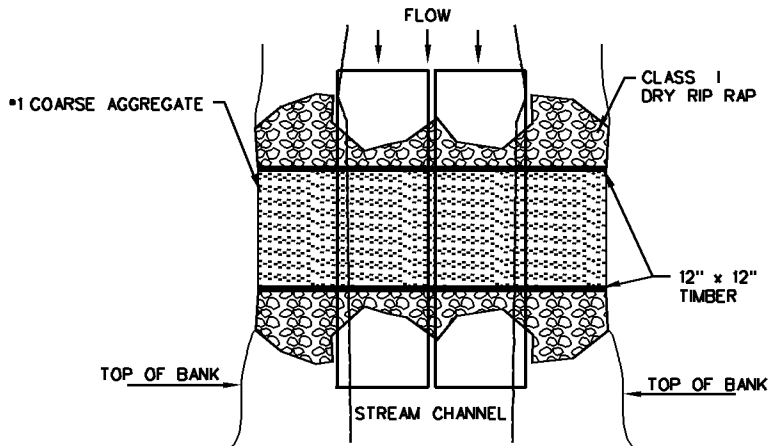

PLAN VIEW

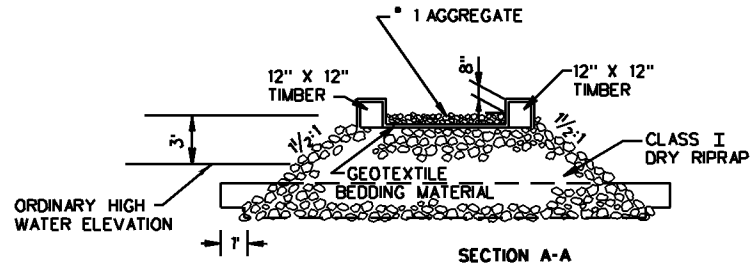
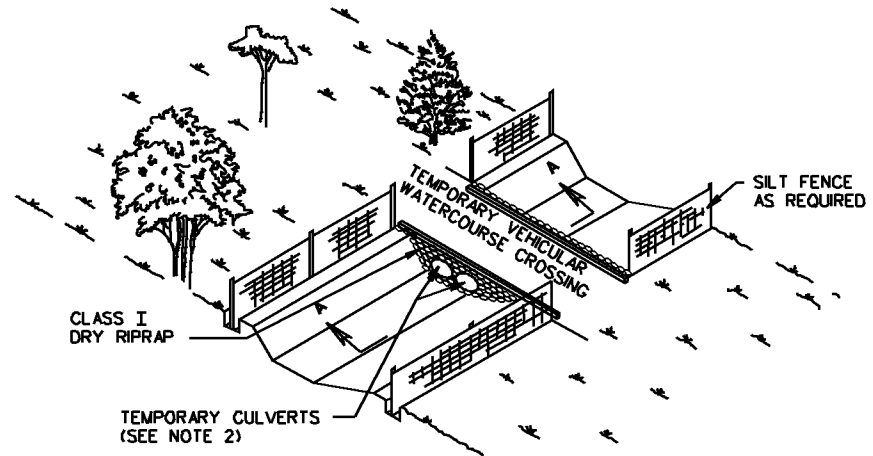

NOTE:

1. THE CULVERT(S) SHALL BE SIZED TO CONVEY THE FLOW OF A TWO YEAR STORM EVENT. THE ELEVATION OF THE TWO YEAR EVENT SHALL BE AT OR BELOW THE LOWEST SURFACE ELEVATION OF THE CROSSING. THE REQUIRED HYDRAULIC OPENINGS SHOULD BE DETERMINED USING THE APPROPRIATE HYDROLOGIC/HYDRAULIC DESIGN TECHNIQUES. A TEMPORARY VEHICULAR WATERCOURSE CROSSING SHOULD ONLY BE UTILIZED WHERE THE DRAINAGE AREA IS NO GREATER THAN 1 SQUARE MILE. THE DEPTH OF STONE COVER OVER THE CULVERT(S) SHALL BE IN ACCORDANCE WITH STANDARD PC-1.

2. AN ALTERNATIVE TEMPORARY VEHICULAR WATERCOURSE CROSSING DESIGN MAY BE USED PROVIDED IT IS SUBMITTED TO THE ENGINEER FOR REVIEW AND APPROVAL IN ACCORDANCE WITH ROAD AND BRIDGE SPECIFICATIONS 105.10 AND 107.02.



ROAD AND BRIDGE STANDARDS

TEMPORARY VEHICULAR WATERCOURSE CROSSING

SPECIFICATION REFERENCE

SHEET 1 OF 1

REVISION DATE

113.18

4/09

VIRGINIA DEPARTMENT OF TRANSPORTATION

302
303
414

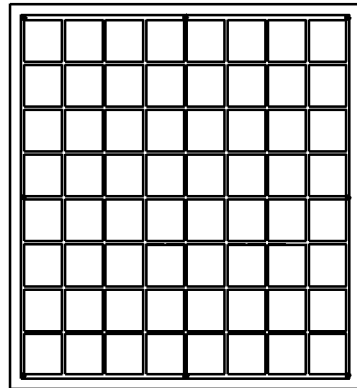

PLAN VIEW

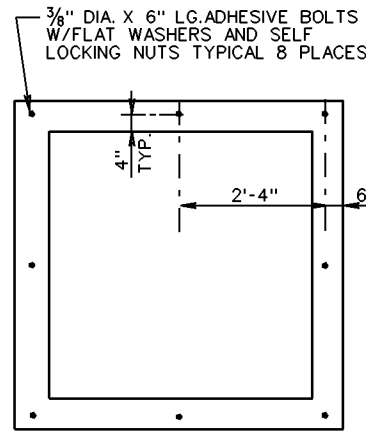

PLAN VIEW
(TRASH RACK NOT SHOWN)

NOTES:

1. COST OF TRASH RACK AND DEBRIS RACK ARE TO BE INCLUDED IN THE BID PRICE FOR THE STORMWATER MANAGEMENT DRAINAGE STRUCTURE.
2. STRUCTURE MAY BE PRECAST OR CAST IN PLACE. SEE SHEET 2 OF 3 FOR DETAILS ON PRECAST STRUCTURE.
3. WEEP HOLES SHALL NOT BE PROVIDED.
4. STEPS ARE TO BE PROVIDED WHEN HEIGHT OF STRUCTURE IS 4'-0" OR GREATER ABOVE INVERT OF OUTLET PIPE. FOR STEP DETAILS SEE STANDARD ST-1.
5. FOR DETAILS ON METAL PLATE, DEBRIS RACK AND TRASH RACK SEE STANDARD SWM-DR.
6. MARK HEIGHT OF STRUCTURE, IN BLACK, WITH 4" HIGH NUMERALS AND 1" WIDE HORIZONTAL STRIPES AT 1' INTERVALS FROM INVERT OF WATER QUALITY ORIFICE (ALL VISIBLE SIDES).
7. THE PERMANENT STORMWATER MANAGEMENT DRAINAGE STRUCTURE, STANDARD SWM-1 MAY BE MODIFIED WHERE THE STORMWATER MANAGEMENT BASIN IS TO BE USED AS A TEMPORARY SEDIMENT BASIN DURING PROJECT CONSTRUCTION. SEE STANDARD SWM-DR, SHEET 1 OF 5, FOR TEMPORARY MODIFICATION DETAILS.
8. THE SIZE OF THE WATER QUALITY ORIFICE SHALL BE SPECIFIED ON THE PLANS. ADDITIONAL OPENINGS IN THE STORMWATER MANAGEMENT DRAINAGE STRUCTURE TO BE PROVIDED WHEN SPECIFIED ON THE PLANS.

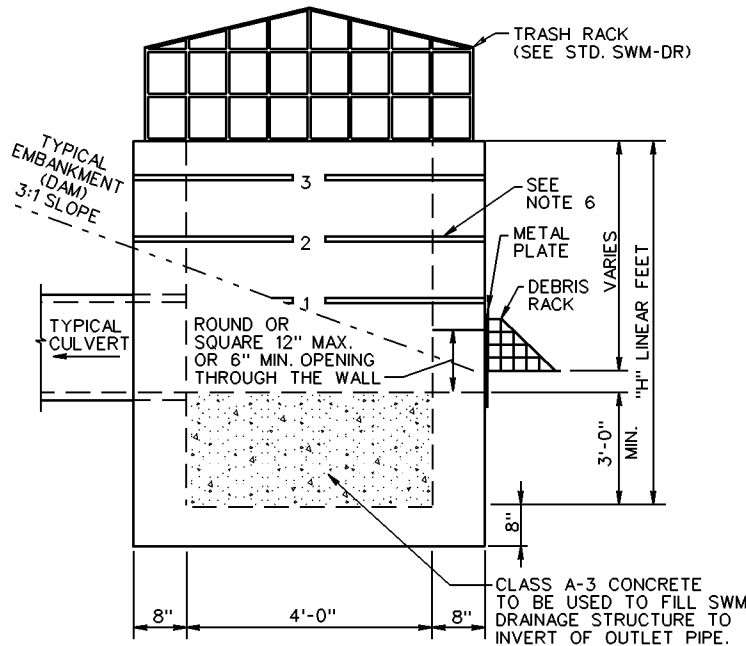

SIDE VIEW
SWM DRAINAGE STRUCTURE

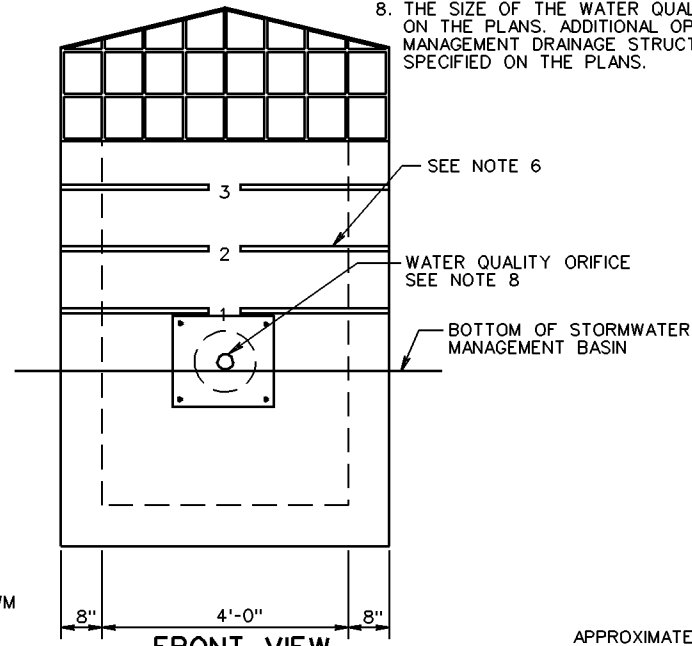

FRONT VIEW
(DEBRIS RACK NOT SHOWN)

APPROXIMATE QUANTITIES
CAST-IN-PLACE CLASS A-3 CONCRETE TO BE USED.
MAXIMUM DEPTH (H) TO BE 12'-8".

PIPE SIZE	12"	15"	18"	24"	30"	36"	42"
MINIMUM DEPTH H	5'-0"	5'-3/4"	5'-6 1/2"	6'-1"	6'-7 1/2"	7'-2"	7'-8 1/2"
CU. YDS. CONCRETE	2.665	2.773	2.878	3.078	3.624	3.437	3.598

INCREMENT PER FOOT OF ADDITIONAL DEPTH "H" = 0.461 CU. YDS.

SPECIFICATION REFERENCE

302

CAST IN PLACE STORMWATER MANAGEMENT DRAINAGE STRUCTURE

VIRGINIA DEPARTMENT OF TRANSPORTATION

VDOT

ROAD AND BRIDGE STANDARDS

REVISION DATE

08/10

SHEET 1 OF 3

114.01

NOTES:

1. COST OF TRASH RACK AND DEBRIS RACK ARE TO BE INCLUDED IN THE PRICE BID FOR THE STORMWATER MANAGEMENT DRAINAGE STRUCTURE.
2. STRUCTURE MAY BE PRECAST OR CAST IN PLACE. SEE SHEET 1 OF 3 FOR DETAILS ON CAST IN PLACE STRUCTURE.
3. WEEP HOLES SHALL NOT BE PROVIDED. ANY LIFT HOLES SHALL BE PLUGGED.
4. STEPS ARE TO BE PROVIDED WHEN HEIGHT OF STRUCTURE IS 4'-0" OR GREATER ABOVE INVERT OF OUTLET PIPE. FOR STEP DETAILS SEE STANDARD ST-1.
5. SEE STANDARD SWM-DR FOR DETAILS ON PLATE, DEBRIS RACK AND TRASH RACK.
6. MARK HEIGHT OF STRUCTURE, IN BLACK, WITH 4" HIGH NUMERALS AND 1" WIDE HORIZONTAL STRIPES AT 1' INTERVALS FROM INVERT OF WATER QUALITY ORIFICE (ALL VISIBLE SIDES).
7. THE PERMANENT STORMWATER MANAGEMENT DRAINAGE STRUCTURE, STANDARD SWM-1 MAY BE MODIFIED WHERE THE STORMWATER MANAGEMENT BASIN IS TO BE USED AS A TEMPORARY SEDIMENT BASIN DURING PROJECT CONSTRUCTION. SEE STANDARD SWM-DR, SHEET 1 OF 5 FOR TEMPORARY MODIFICATION DETAILS.
8. THE SIZE OF THE WATER QUALITY ORIFICE SHALL BE SPECIFIED ON THE PLANS. ADDITIONAL OPENINGS IN THE STORMWATER MANAGEMENT STRUCTURE TO BE PROVIDED WHEN SPECIFIED ON THE PLANS.

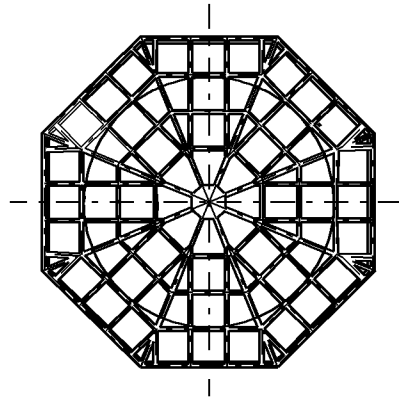

PLAN VIEW

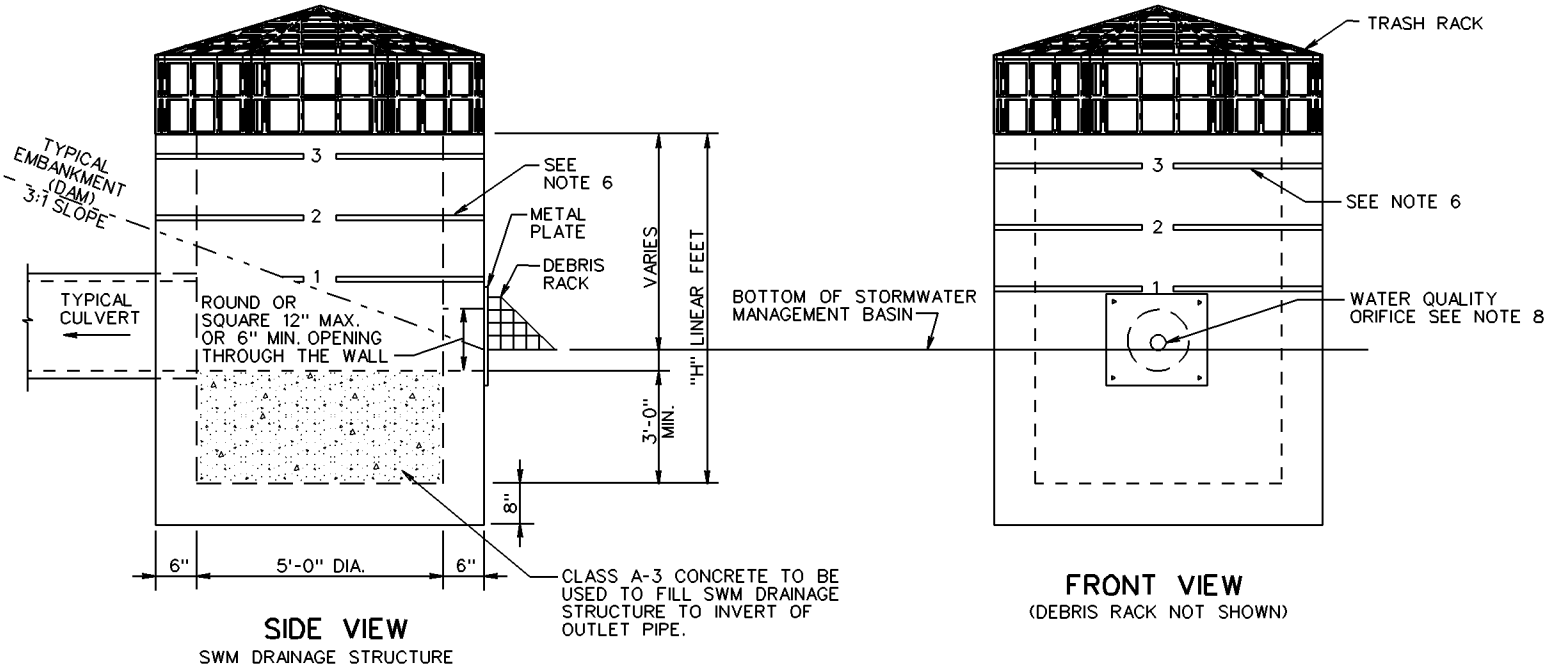

SIDE VIEW

SWM DRAINAGE STRUCTURE

FRONT VIEW

(DEBRIS RACK NOT SHOWN)



ROAD AND BRIDGE STANDARDS

PRECAST STORMWATER MANAGEMENT DRAINAGE STRUCTURE

SPECIFICATION REFERENCE

SHEET 2 OF 3

REVISION DATE

114.02

08/10

VIRGINIA DEPARTMENT OF TRANSPORTATION

105
302

THIS PAGE INTENTIONALLY LEFT BLANK

SPECIFICATION
REFERENCE

VIRGINIA DEPARTMENT OF TRANSPORTATION



ROAD AND BRIDGE STANDARDS

REVISION DATE

SHEET 1 OF 1

114.03

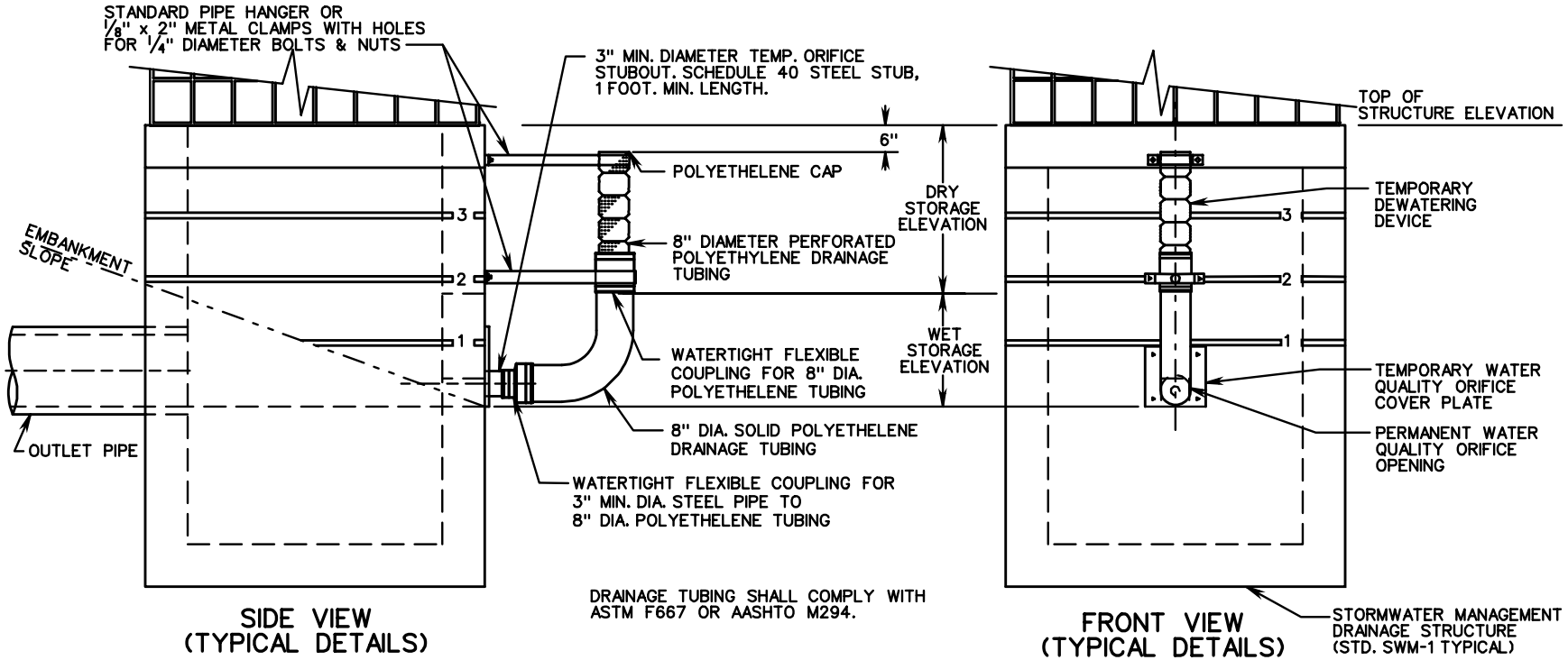

NOTES:

1. THESE DETAILS ARE TO BE USED TO MODIFY THE PERMANENT STORMWATER MANAGEMENT DRAINAGE STRUCTURE WHERE THE STORMWATER MANAGEMENT BASIN IS TO BE USED FOR A TEMPORARY SEDIMENT BASIN DURING PROJECT CONSTRUCTION.
2. GRADE STORMWATER MANAGEMENT BASIN AS SHOWN IN PLANS.
3. ALL OPENINGS (IF ANY) IN SIDE OF STRUCTURE (OTHER THAN PERMANENT WATER QUALITY ORIFICE) ARE TO BE COVERED WITH SOLID METAL PLATES WHILE THE BASIN IS BEING USED FOR SEDIMENT CONTROL.
4. DEWATERING DEVICE AND COMPONENTS AND TEMPORARY METAL PLATES (IF ANY), AS SHOWN IN THE DETAIL, ARE TO BE REMOVED AND PERMANENT STEEL PLATE WITH WATER QUALITY ORIFICE IS TO BE INSTALLED WHEN BASIN IS NO LONGER NEEDED FOR SEDIMENT CONTROL.
5. SIMILAR DEVICE MAY ALSO BE USED ON OTHER STORMWATER MANAGEMENT DRAINAGE STRUCTURES.
6. COST OF TEMPORARY DEWATERING DEVICE AND TEMPORARY METAL PLATES (IF ANY) SHALL BE INCLUDED IN THE BID PRICE FOR STORMWATER MANAGEMENT DRAINAGE STRUCTURE.
7. THE TEMPORARY 8" DIA. POLYETHYLENE DRAINAGE TUBING IS TO BE SOLID FOR THE LENGTH BELOW WET STORAGE ELEVATION AND IS TO BE PERFORATED ABOVE THE WET STORAGE ELEVATION. THE COUPLING IS TO BE WATERTIGHT.



ROAD AND BRIDGE STANDARDS

SHEET 1 OF 5

REVISION DATE

114.04

STORMWATER MANAGEMENT (SWM) DETAILS

VIRGINIA DEPARTMENT OF TRANSPORTATION

SPECIFICATION REFERENCE

302

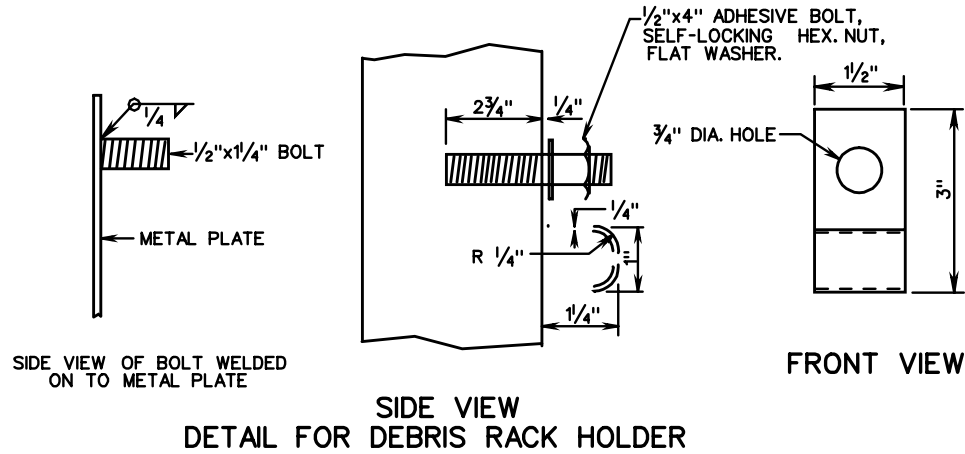

1. COST OF DEBRIS RACK, METAL PLATE, AND DEBRIS RACK HOLDER TO BE INCLUDED IN THE BID PRICE FOR THE SWM DRAINAGE STRUCTURE.
2. DEBRIS RACK MAY BE FABRICATED FROM WELDED 3/8" DIAMETER BARS OR 1/2" THICK HIGH DENSITY POLYETHYLENE. METAL COMPONENTS OF DEBRIS RACK MUST NOT BE GALVANIZED.
3. DEBRIS RACK TO BE HINGED AS SHOWN OR CONTRACTOR MAY SUBSTITUTE A COMPARABLE DESIGN AS APPROVED BY THE ENGINEER.
4. THE LOCATION OF THE DEBRIS RACK HOLDER MAY BE ADJUSTED FOR VARIABLE CONDITIONS. WHEN HOLDER BOLT IS LOCATED ON THE METAL PLATE THE 1/2" DIA. BOLT LENGTH IS TO BE REDUCED 1/4" LG. AND WELDED TO THE PLATE. DEBRIS RACK HOLDER AND ALL HARDWARE IS TO BE GALVANIZED.

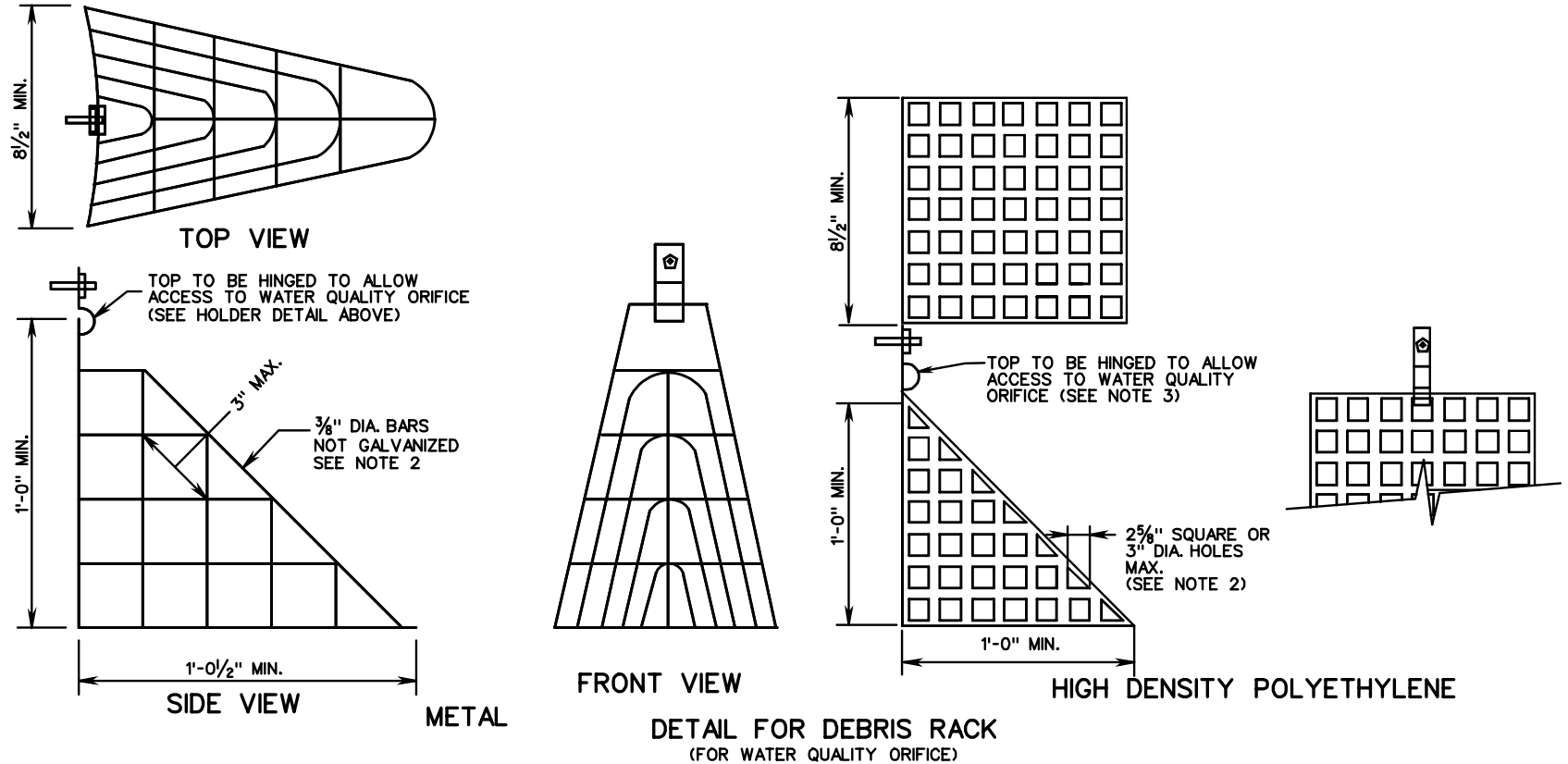

SPECIFICATION REFERENCE

302

STORMWATER MANAGEMENT (SWM) DETAILS
DEBRIS RACK, METAL PLATE, WATER QUALITY ORIFICE, CONCRETE CRADLE
(FOR SWM DRAINAGE STRUCTURES, SWM RISER PIPES AND SWM DAMS)
 VIRGINIA DEPARTMENT OF TRANSPORTATION

VDOT

ROAD AND BRIDGE STANDARDS

REVISION DATE

SHEET 2 OF 5

114.05

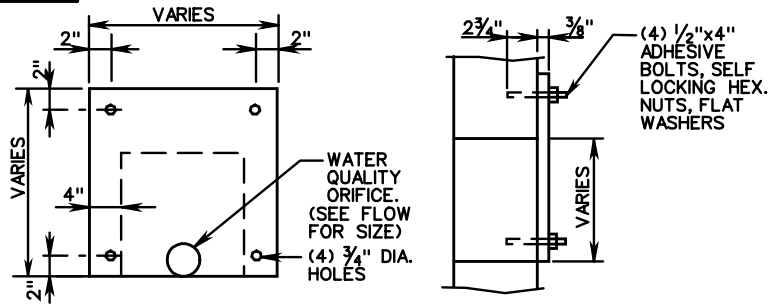

SWM DAM METAL PLATE DETAIL
(NOT GALVANIZED)

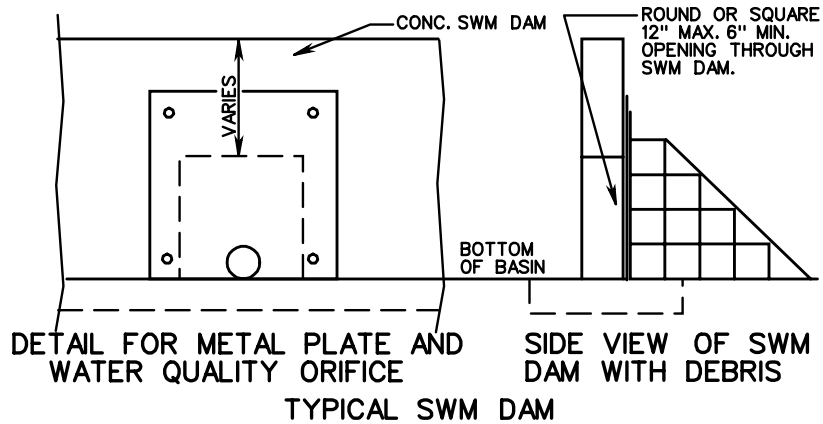

TYPICAL SWM DAM

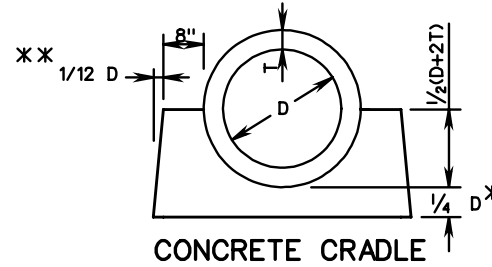

PIPE SIZE INCHES	CRADLE BOTTOM WIDTH (INCHES)	CRADLE HEIGHT (INCHES)	CRADLE TOP WIDTH (INCHES)	INCREMENT, IN CUBIC YARDS, PER LINEAR FOOT OF PIPE
12	34	14	32	0.093
15	38	15.75	35.5	0.110
18	42	17.5	39	0.129
24	50	21	46	0.168
30	58	26	53	0.233
36	66	31	60	0.307
42	74	36	67	0.390

CONCRETE SHALL BE CLASS A3 BUT NOT LESS THAN 6"
 * IF THE PIPE IS LAID IN AN EXCAVATED TRENCH, THEN THE SIDE WALLS MAY CONFORM TO THE TRENCH SHAPE (IE THE TRENCH MAY BECOME THE CRADLE FORM).
 CONCRETE CRADLE IS TO BE INSTALLED UNDER THE ENTIRE LENGTH OF CULVERT AT EACH STORMWATER MANAGEMENT BASIN.
 CONCRETE CRADLE IS TO BE PAID FOR AS MISCELLANEOUS CONCRETE AND SUMMARIZED IN CUBIC YARDS FOR EACH PIPE LOCATION

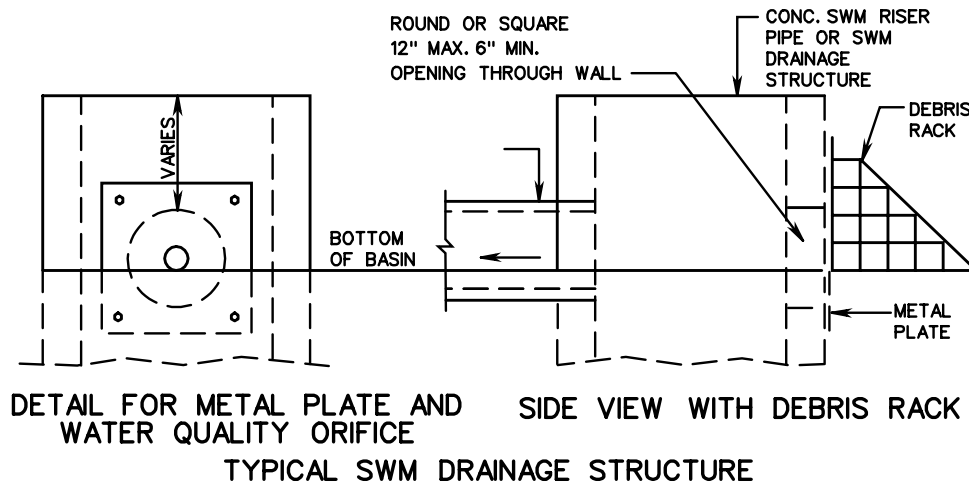
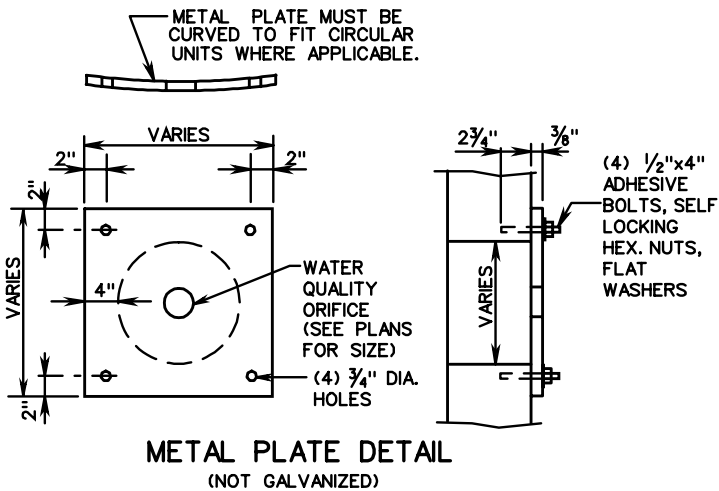

TYPICAL SWM DRAINAGE STRUCTURE

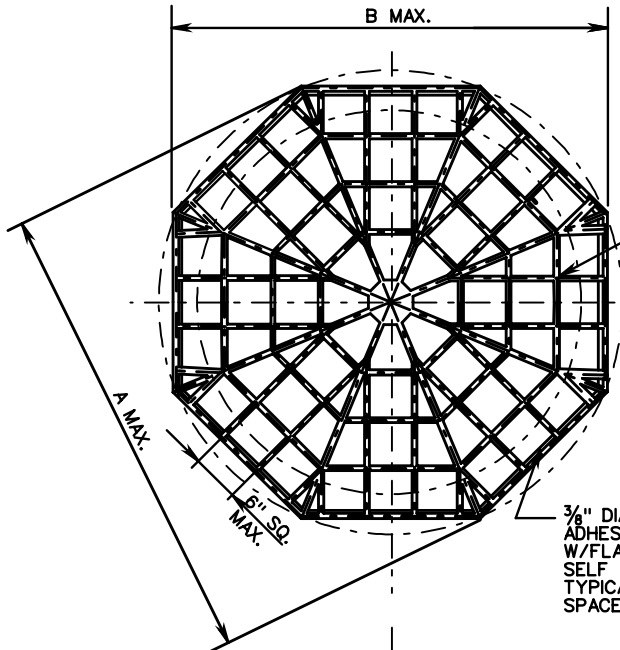

3/8" DIA. X 6" LG. ADHESIVE BOLTS W/FLAT WASHERS AND SELF LOCKING NUTS TYPICAL 8 PLACES-EQUALLY SPACED ON AN "E" DIA. B.C.

LOCKABLE ACCESS DOOR W/HINGE, MIN. 2' x 2' CLEAR OPENING SEE NOTE 1

3/8" DIA. X 6" LG. ADHESIVE BOLTS W/FLAT WASHERS AND SELF LOCKING NUTS. TYPICAL 8 PLACES-EQUALLY SPACED ON AN "E" DIA. B.C.

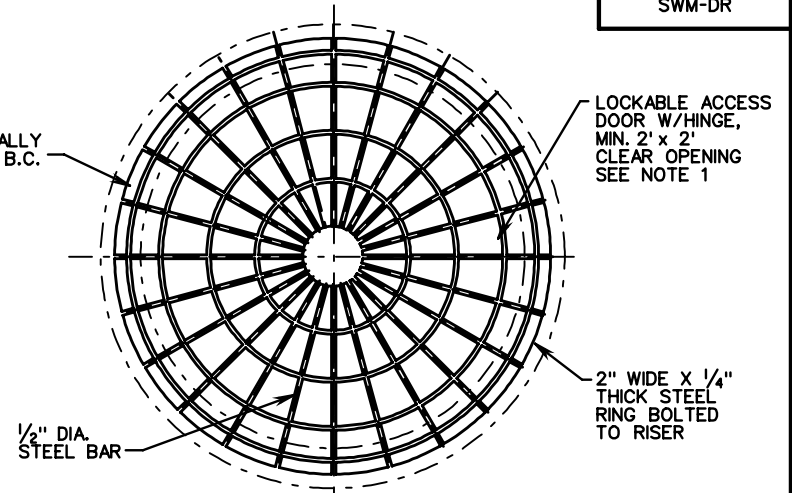

LOCKABLE ACCESS DOOR W/HINGE, MIN. 2' x 2' CLEAR OPENING SEE NOTE 1

2" WIDE X 1/4" THICK STEEL RING BOLTED TO RISER

1/2" DIA. STEEL BAR

1/2" THICK STEEL PLATE

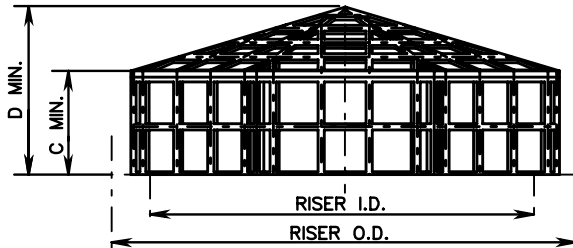

CIRCULAR STORMWATER MANAGEMENT DRAINAGE STRUCTURE

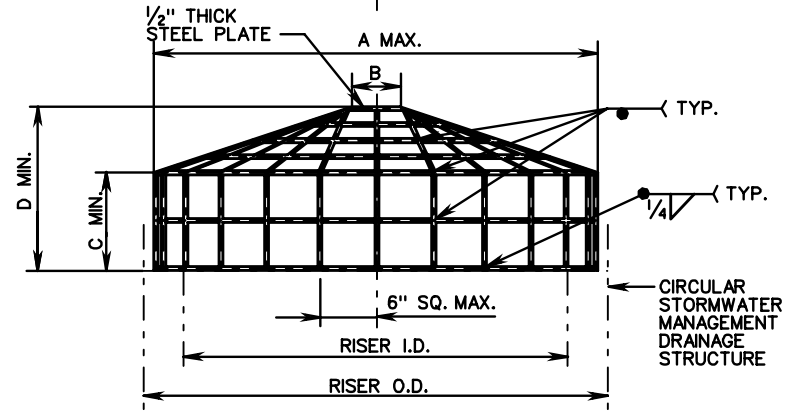

CIRCULAR STORMWATER MANAGEMENT DRAINAGE STRUCTURE

RISER		DIMENSION					APPROX. WT. (LBS.)
I.D.	O.D.	A	B	C	D	E	
24	30	31	28 ⁵ / ₈	7	11	27	24
36	44	45	41 ¹ / ₂	13	19	40	58
48	58	59	54 ¹ / ₂	13	21	53	86
60	72	73	67 ¹ / ₂	17	28	66	135
72	86	87	80 ³ / ₈	23	35	79	204
84	100	101	93 ³ / ₄	25	39	92	266
96	114	115	106 ¹ / ₄	22	38	105	305

HIGH DENSITY POLYETHYLENE

RISER		DIMENSION					APPROX. WT. (LBS.)	
I.D.	O.D.	A	B	C	D	E	SEGMENT	
24	30	30	6	7	10	27	15	46
36	44	42	6	13	18	40	22	82
48	58	55	9	13	20	53	29	120
60	72	68	9	17	26	66	36	169
72	86	81	9	23	34	79	42	227
84	100	94	12	25	37	92	49	290
96	114	107	12	22	36	105	56	341

METAL

NOTES:

1. A HINGED, LOCKABLE ACCESS DOOR SHALL BE PROVIDED ON ALL TRASH RACKS IF THE TOTAL WEIGHT OF THE TRASH RACK IS GREATER THAN 75 LBS OR IF THE TRASH RACK IS TO BE PLACED ON A SWM-1 WITH AN "H" DIMENSION GREATER THAN 7'-2".

2. ANTI-VORTEX PLATE IS TO BE USED WHEN SPECIFIED ON THE PLANS. COST OF FURNISHING AND PLACING THE ANTI-VORTEX PLATE IS TO BE INCLUDED IN THE BID PRICE FOR THE STRUCTURE.

SPECIFICATION REFERENCE

302

STORMWATER MANAGEMENT DETAILS TRASH RACK FOR SWM DRAINAGE STRUCTURES

VIRGINIA DEPARTMENT OF TRANSPORTATION

VDOT

ROAD AND BRIDGE STANDARDS

REVISION DATE

SHEET 4 OF 5

114.07

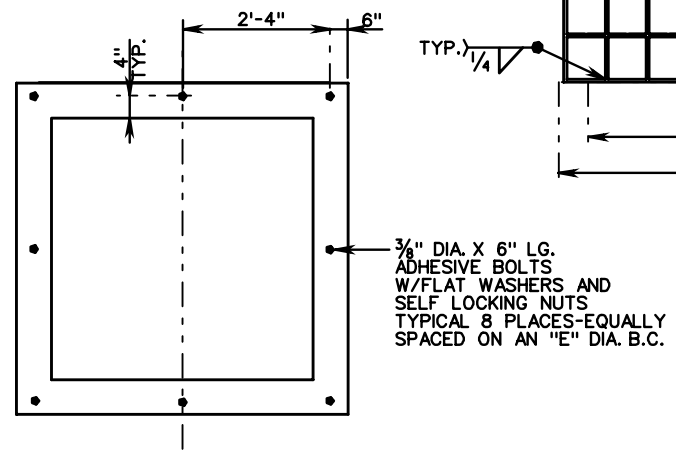
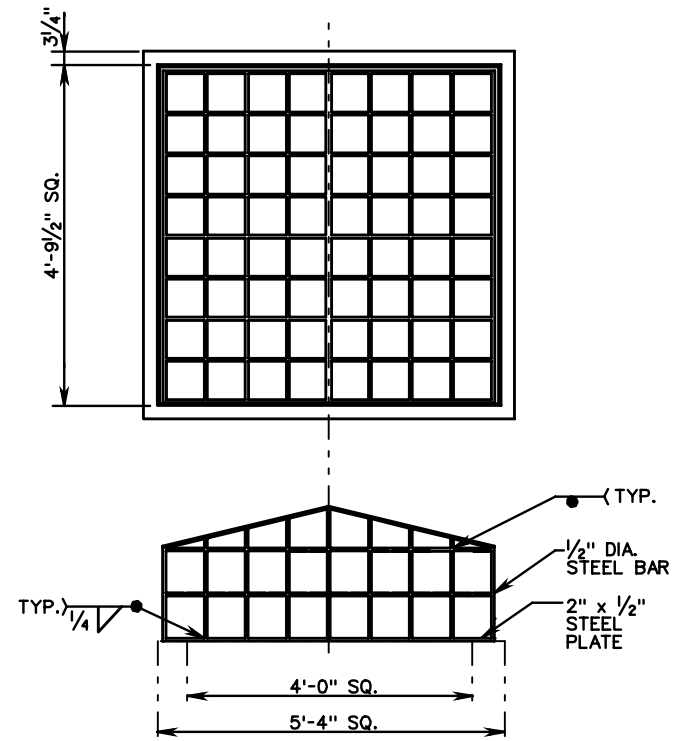
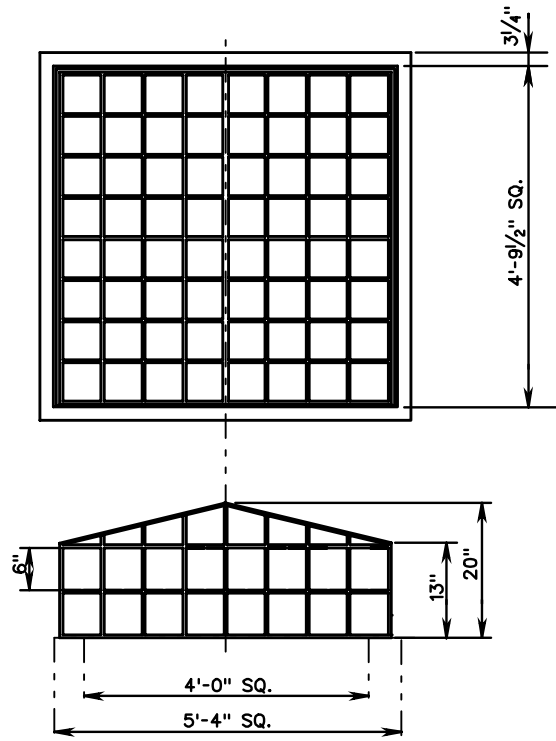

NOTE:
A HINGED, LOCKABLE ACCESS DOOR
WITH A MINIMUM 2' x 2' CLEAR OPENING,
SHALL BE PROVIDED ON ALL TRASH RACKS.

HIGH DENSITY POLYETHYLENE

APPROX. WT. (LBS.)
95

METAL (STEEL)

APPROX. WT. (LBS.)
188