

PROJECT MANAGER _____
 SURVEYED BY _____
 DESIGN SUPERVISED BY _____
 DESIGNED BY _____

DESIGN FEATURES RELATING TO CONSTRUCTION OR TO REGULATION AND CONTROL OF TRAFFIC MAY BE SUBJECT TO CHANGE AS DEEMED NECESSARY BY THE DEPARTMENT

REVISED	STATE	FEDERAL AID	ROUTE	STATE	SHEET NO.
	VA.	PROJECT		PROJECT	

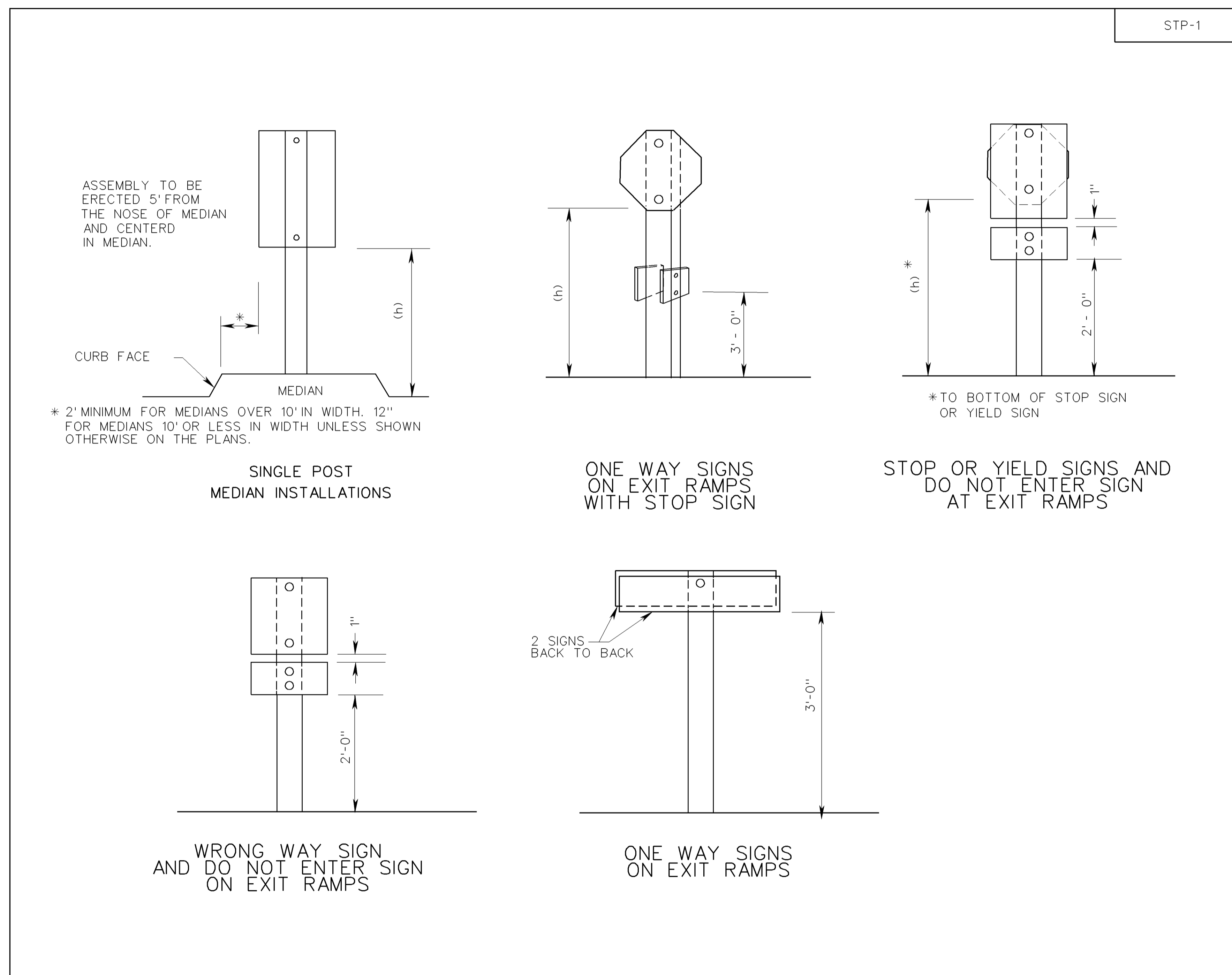

STP-1

SPECIFICATION REFERENCE	<h2>SQUARE TUBE SIGN POST</h2> <p>VIRGINIA DEPARTMENT OF TRANSPORTATION</p>	<p>ROAD AND BRIDGE STANDARDS</p>	
700		REVISION DATE 6-15-09	SHEET 3 OF 3 1321.12

6/18/2009 14:34:36