

MEDIAN WITH CUT-THROUGH
TYPE M2

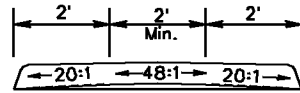

SECTION C-C

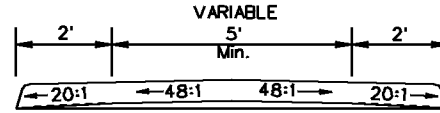

SECTION B-B

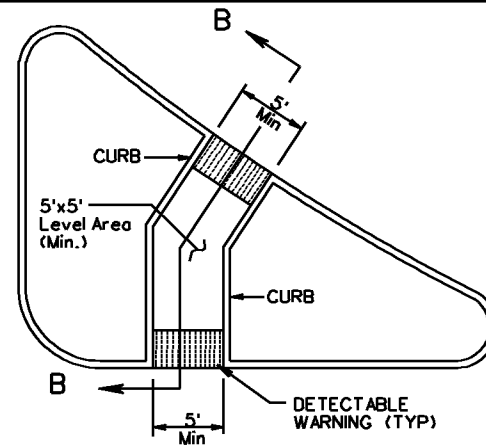

REFUGE ISLAND WITH RAMPS
TYPE RI1

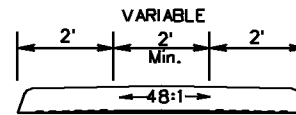

SECTION D-D

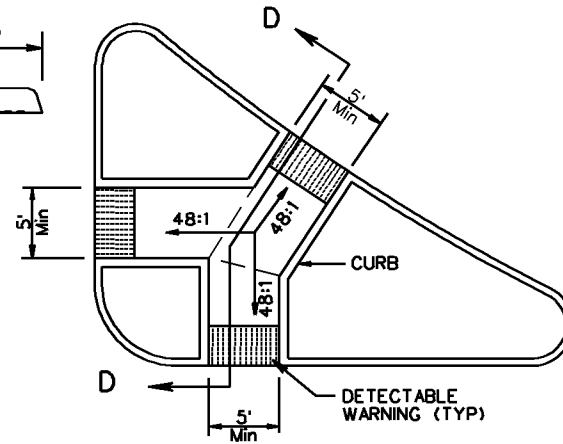

REFUGE ISLAND CUT - THROUGH
TYPE RI2

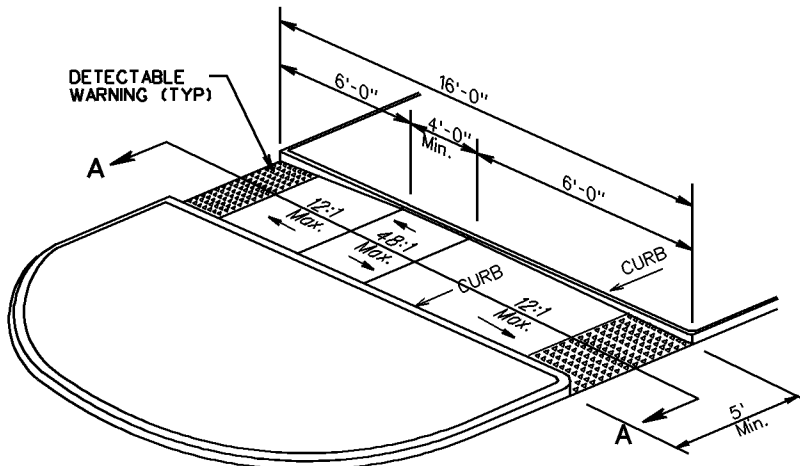

MEDIAN WITH RAMP
TYPE M1

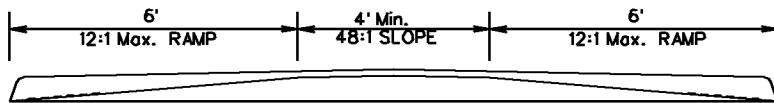

SECTION A-A

NOTES:

1. FOR GENERAL NOTES ON THE DETECTABLE WARNING SURFACE, SEE SHEET 1 OF 5.
2. CURB SHALL BE SHAPED TO MATCH THE FACE OF ROADWAY CURB.
3. SEE ROADWAY PLANS FOR MEDIAN AND REFUGE ISLAND DIMENSIONS.
4. RAMPS AND CUT THROUGH SHALL BE ALIGNED WITH CROSSWALKS.



ROAD AND BRIDGE STANDARDS

SHEET 5 OF 5

REVISION DATE

203.08A

10/09

CG-12 DETECTABLE WARNING SURFACE

MEDIAN AND REFUGE ISLAND APPLICATIONS

VIRGINIA DEPARTMENT OF TRANSPORTATION

SPECIFICATION
REFERENCE

105
502