

DETAIL A
FOUNDATION NOT IN
SIDEWALK DETAIL

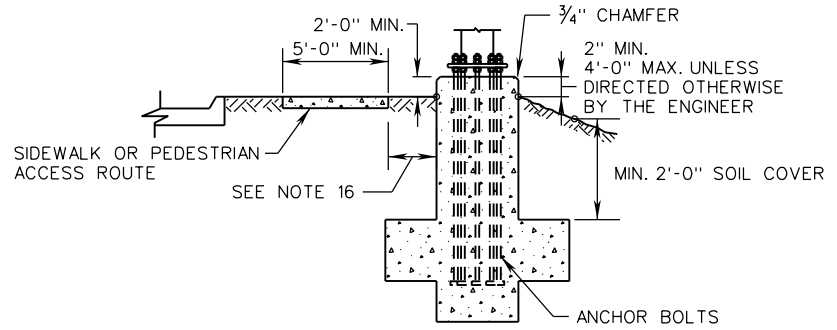

DETAIL B
FOUNDATION ADJACENT
TO SIDEWALK DETAIL

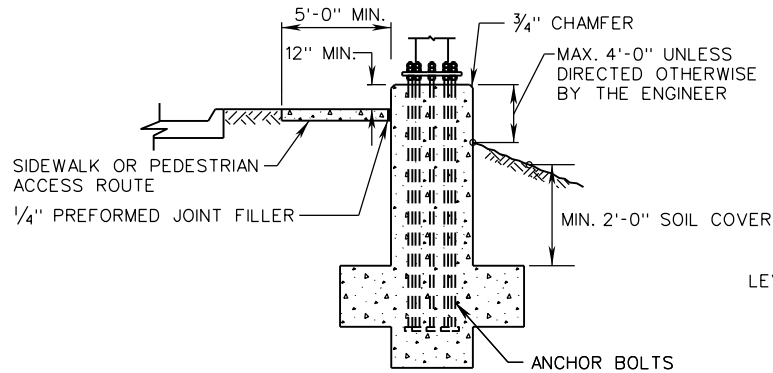

DETAIL C
ALTERNATE FOUNDATION
ADJACENT TO SIDEWALK DETAIL
(IF APPROVED BY THE ENGINEER)

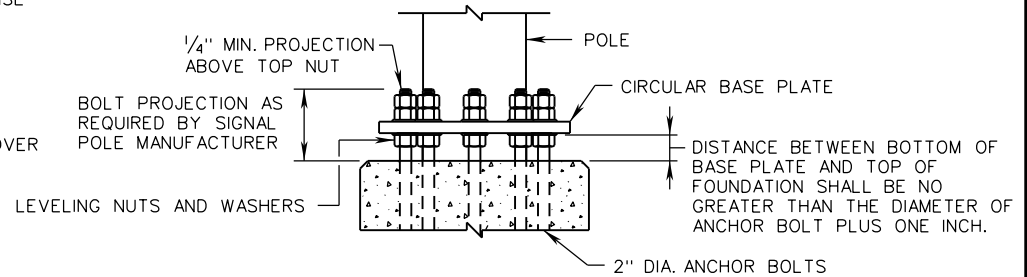

DETAIL D
ANCHOR BOLT AND BASE
PLATE CONNECTION DETAIL

SPECIFICATION
REFERENCE

700

A COPY OF THE ORIGINAL SEALED AND SIGNED DRAWING IS ON FILE IN THE CENTRAL OFFICE.

SIGNAL POLE FOUNDATION

INSTALLATION DETAILS

VIRGINIA DEPARTMENT OF TRANSPORTATION

VDOT

ROAD AND BRIDGE STANDARDS

REVISION DATE

08/14

SHEET 2 OF 2

1310.13