

**SILT BARRIERS**  
**TYPICAL DETAIL FOR BRUSH BARRIER**  
 (TO BE USED AT ALL APPLICABLE LOCATIONS)

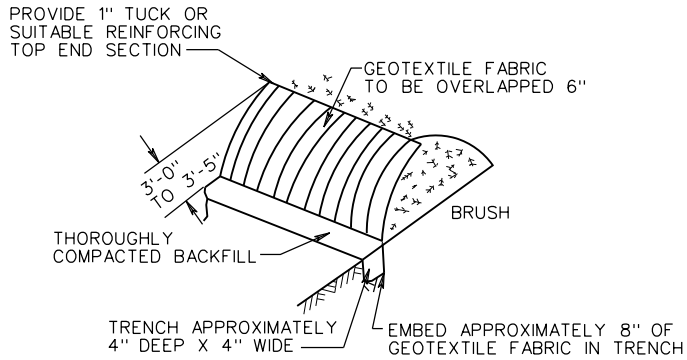

**NOTES:**

- BRUSH BARRIERS SHALL BE CONSTRUCTED AT LOCATION SHOWN ON THE PLANS OR AS DIRECTED BY THE ENGINEER. BRUSH SHALL BE PILED AGAINST EXISTING TREES TO PREVENT MOVEMENT OF BARRIER. BRUSH SHALL BE PILED AS TIGHTLY AS POSSIBLE AND WEIGHTED DOWN BY UNMERCHANTABLE LOGS.
- GEOTEXTILE FABRIC CONFORMING TO THE ROAD AND BRIDGE SPECIFICATIONS SHALL BE INSTALLED AS DETAILED ABOVE. GEOTEXTILE FABRIC MAY ALSO BE ATTACHED TO EXISTING FENCES WHEN SPECIFIED ON THE PLANS OR DIRECTED BY THE ENGINEER.
- NO BRUSH WILL BE DESTROYED OR REMOVED FROM THE PROJECT UNTIL ALL BRUSH SILT BARRIERS ARE IN PLACE AND HAVE BEEN INSPECTED AND APPROVED BY THE ENGINEER.
- DIMENSIONS SHOWN ARE APPROXIMATE ONLY.

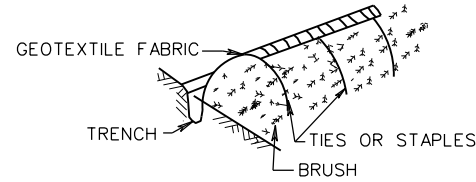
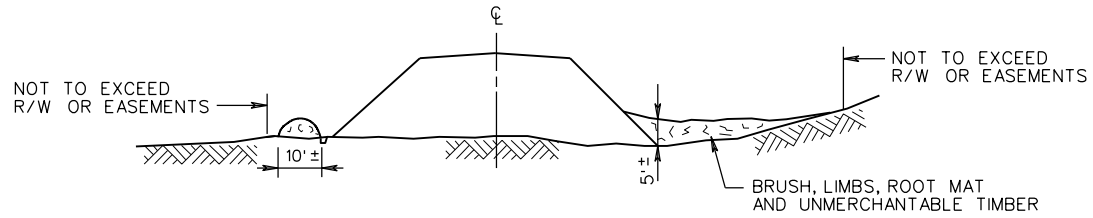
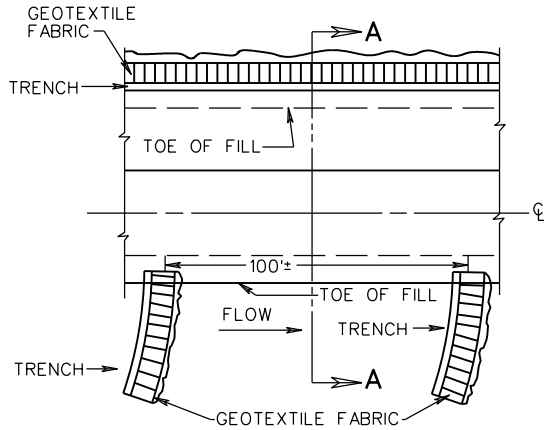

ROAD AND BRIDGE STANDARDS

SHEET 4 OF 4

REVISION DATE

113.08

08/14

**TEMPORARY SILT BARRIERS**  
**SILT FENCE (TYPE A & B), AND BRUSH BARRIER**

VIRGINIA DEPARTMENT OF TRANSPORTATION

SPECIFICATION REFERENCE

107  
303