

FE-W1,W2

CORNER BRACE

LINE BRACE

LINE BRACE AT END LOCATION

WOOD
POST

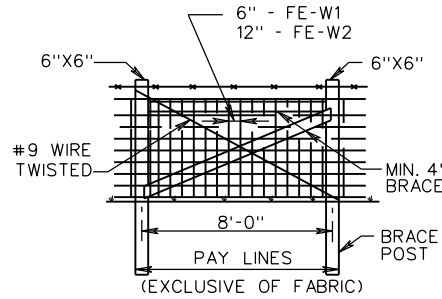
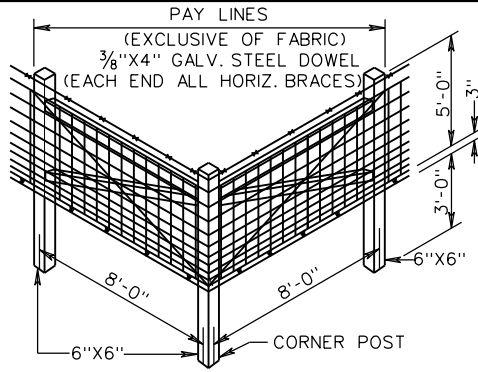

THE BRACE WIRE TO BE PLACED AROUND POSTS WITH ONE WIRE ON EACH SIDE OF BRACE. WIRE TO BE DRAWN TAUT BY TWISTING BETWEEN BRACE AND EACH POST. THIS APPLIES TO ALL BRACE WIRES.

DIAGONAL 4" BRACES TO BE PLACED IN DIRECTION OF PULL. POST TO BE NOTCHED FOR DIAGONAL 4" BRACES. ALL 4" DIAGONAL BRACES TO HAVE TWO GALVANIZED 12D NAILS EACH END.

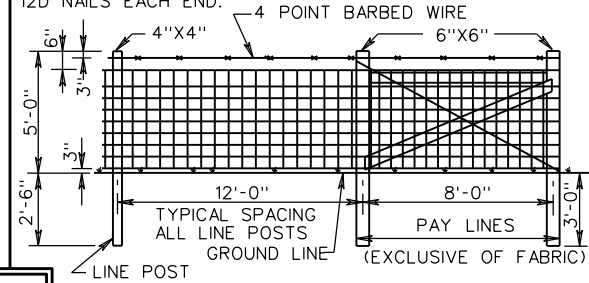

METAL
POST

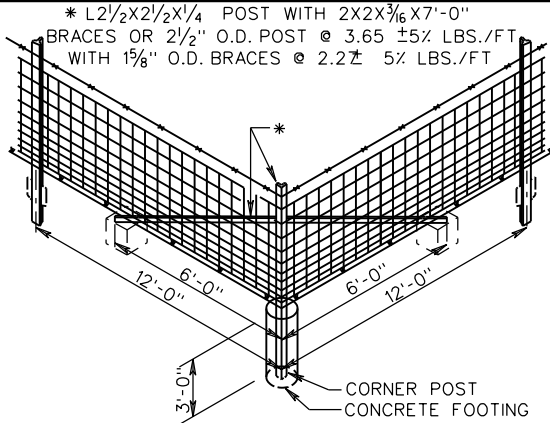

IF NOT OTHERWISE NOTED DIMENSIONS AND DESCRIPTIONS SHOWN ON ONE DRAWING APPLY TO OTHER DETAILS WITH THE SAME POST TYPE.

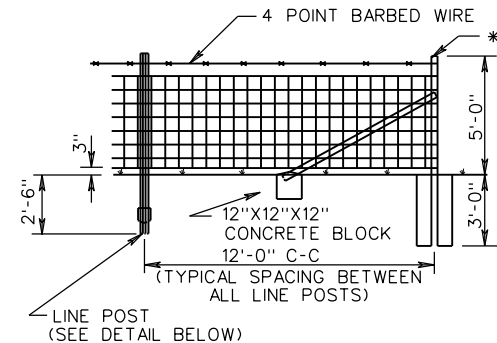
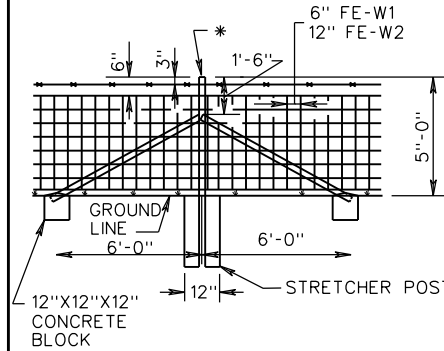

NOTES:

SEE GENERAL NOTES-FENCING FOR ADDITIONAL DETAILS AND INSTRUCTIONS.

LINE POSTS ARE TO BE OF THE TYPES SHOWN OR EQUIVALENT MEETING THE APPROVAL OF THE ENGINEER.

ALL POSTS ARE TO HAVE A MINIMUM WEIGHT OF 1.25 LBS./FT.

A MINIMUM OF FIVE CLAMPS FOR ATTACHING FABRIC TO POST ARE TO BE INCLUDED IN COST OF EACH LINE POST.

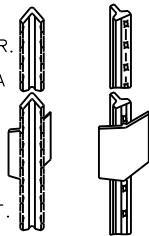

FLANGED FLANGE
TYPE "U" TYPE "T"

METAL LINE POST

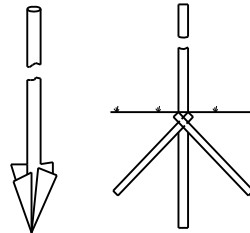

FOR USE IN LIEU OF SETTING POSTS IN CONCRETE. DEVICES SHOWN ARE REPRESENTATIONAL ONLY. SEE GENERAL NOTES.

ALTERNATE ANCHOR DEVICES

L2X2X3/8 TO BE CUT TO FIT AROUND L2 1/2 X 2 1/2 X 1/4 STRETCHER POST.

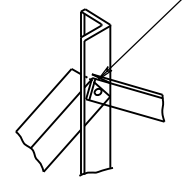

L2 1/2 X 2 1/2 X 1/4, 2" LONG BRACKET BOLTED TO STRETCHER POST

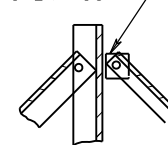

ALTERNATE

METHOD OF ATTACHING ANGLE BRACES TO STRETCHER POSTS



ROAD AND BRIDGE STANDARDS

SHEET 1 OF 1

REVISION DATE

503.02

7/13

**STANDARD FENCE
WOVEN WIRE FABRIC**

VIRGINIA DEPARTMENT OF TRANSPORTATION

SPECIFICATION
REFERENCE

242
507
236