

FRONT ELEVATION

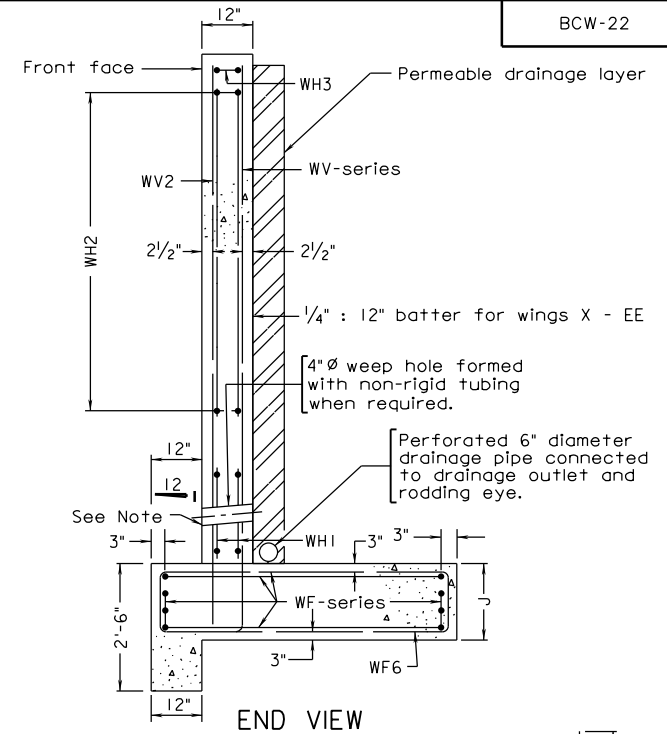

END VIEW

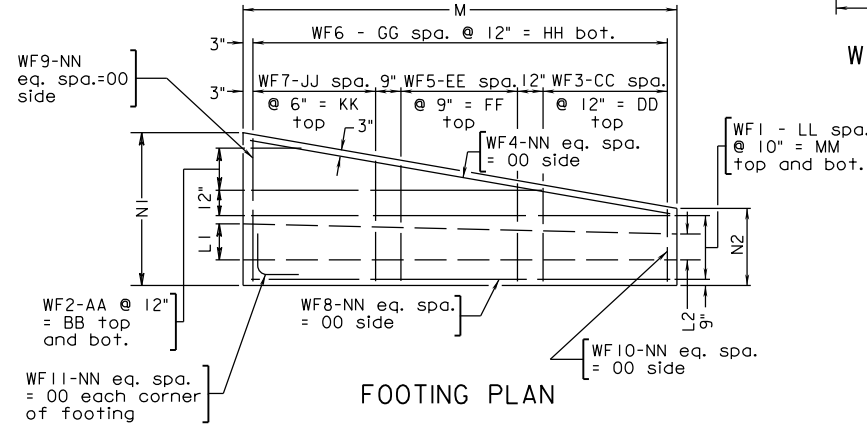

FOOTING PLAN

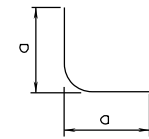

WF11

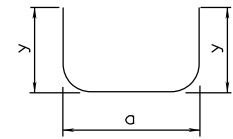

WF1 TO WF3, WF5 TO WF7

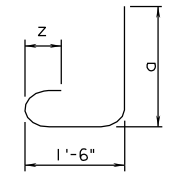

WV1, WV3, WV4

TABLE A	
Wall	y
A-W	9 1/2"
X	1'-0 1/2"
Y-CC	1'-3 1/2"
DD-EE	1'-9 1/2"

TABLE B		
Bar Size	Pin Dia.	Z
#3	2 1/4"	4"
#4	3"	4 1/2"
#5	3 3/4"	5"
#6	4 1/2"	6"
#7	5 1/4"	7"
#8	6"	8"
#9	9"	10 1/8"

TABLE C	
Bar Size	Splice Length
#4	1'- 9"
#5	2'- 4"
#6	2'- 7"
#7	3'- 3"
#8	4'- 2"
#9	5'- 4"

A COPY OF THE ORIGINAL SEALED AND SIGNED DRAWING AND DESIGN STATEMENT IS ON FILE IN THE CENTRAL OFFICE.

SPECIFICATION REFERENCE  	<h2 style="margin:0;">WING DETAIL</h2> <h3 style="margin:0;">2:1 FILL SLOPE - TYPE II</h3> <p style="margin:0;">VIRGINIA DEPARTMENT OF TRANSPORTATION</p>	ROAD AND BRIDGE STANDARDS	REVISION DATE 07/12	SHEET 2 OF 8 1007.10
---------------------------------	---	---------------------------	------------------------	-------------------------