

\* 27<sup>3</sup>/<sub>4</sub>" MIN - 28<sup>3</sup>/<sub>4</sub>" MAX RAIL HEIGHT

GR-2A

(3'-1/2" POST SPACING)  
MAX DYNAMIC DEFLECTION = 2'

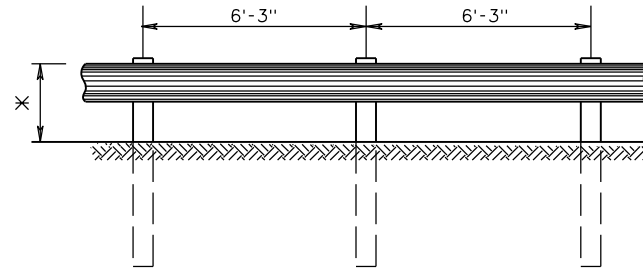

GR-2

(6'-3" POST SPACING)  
MAX DYNAMIC DEFLECTION = 3'

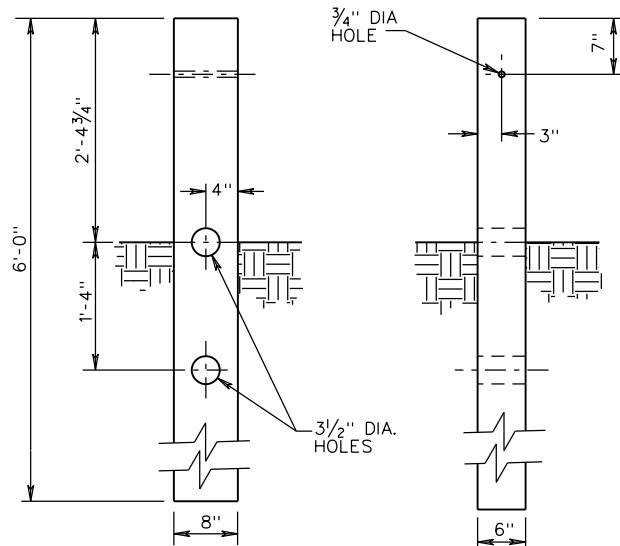

CRT POST

NOTES:

GUARDRAIL LOCATIONS SHOWN ON PLANS ARE APPROXIMATE ONLY AND CAN BE ADJUSTED DURING CONSTRUCTION IF AND AS DIRECTED BY THE ENGINEER.

FOR DETAILS OF POST AND BLOCKOUTS SEE SHEET NO. 501.05.

FOR DETAILS OF RAIL ELEMENT, RAIL SPLICE JOINT, AND ASSOCIATED HARDWARE SEE SHEET NOS. 501.01 AND 501.02.

RAIL ELEMENTS ARE FURNISHED SHOP CURVED FOR RADII BETWEEN 5 FEET AND 150 FEET.

ALL GUARDRAIL POSTS SHALL BE SET PLUMB. POST SHALL NOT BE SET WITH A VARIATION OF MORE THAN 1/8" PER FOOT FROM VERTICAL. W-BEAM, BLOCKOUTS, AND POSTS SHALL BE SET AND ALIGNED WITHOUT ALTERATION OR FORCE, AS PER SECTION 505 OF THE SPECIFICATIONS.

ALL GR-2 AND GR-2A RAIL SHALL BE MAINTAINED AT A HEIGHT OF 27<sup>3</sup>/<sub>4</sub>" MIN - 28<sup>3</sup>/<sub>4</sub>" MAX AS MEASURED PER STANDARD GR-INS.

ALL W-BEAM RAILS SHALL BE LAPPED IN THE DIRECTION OF VEHICULAR TRAVEL FOR THE FINISHED ROADWAY.



ROAD AND BRIDGE STANDARDS

STANDARD BLOCKED-OUT W-BEAM GUARDRAIL  
(STRONG POST SYSTEM)

SPECIFICATION REFERENCE

SHEET 1 OF 2

REVISION DATE

221  
505

501.04

7/11

VIRGINIA DEPARTMENT OF TRANSPORTATION