

TO JUNCTION BOX

SECTION B-B SAW SLOTS AND PVC CONDUITS SHALL BE A MINIMUM 6" BETWEEN ADJACENT SAW SLOTS AND CONDUITS. IF THE JUNCTION BOX WIDTH REQUIRES THE CONDUITS TO BE CLOSER THAN 6", THE CONDUITS SHALL BE 6" BETWEEN EACH OTHER AT THE END OF THE SAW SLOT AND THEN TAPERED TO THE REQUIRED SPACING AT THE JUNCTION BOX.

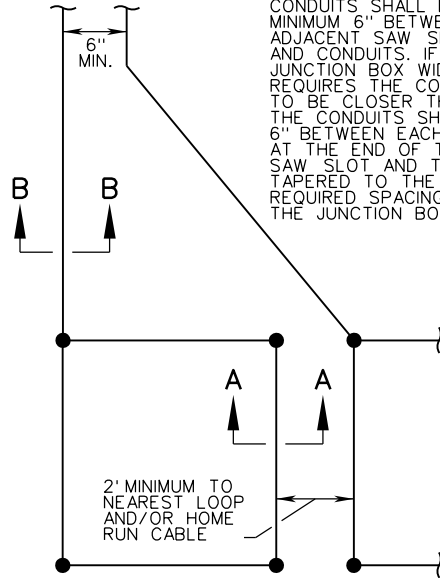

TYPICAL LOOP WIRE PLAN

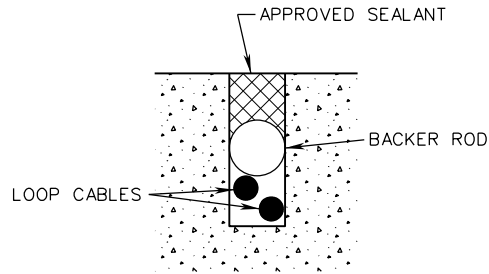

CROSS SECTION TYPICAL SEALED SLOT

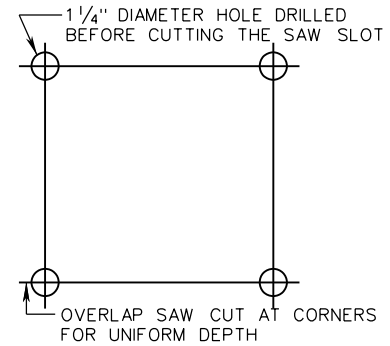

TYPICAL SAW CUT DIAGRAM

NOTES:

- SAW SLOT SHALL BE 5/8" WHEN LOOP DETECTOR CABLE ENCLOSED IN TUBING IS INSTALLED.
- IN NEW ASPHALT CONCRETE ROADWAYS, SAW SLOTS SHALL BE CUT INTO THE BASE COURSE TO A DEPTH OF 3".  
IN EXISTING ASPHALT CONCRETE ROADWAYS WHICH ARE TO BE RESURFACED AS PART OF THE PROJECT, SAW SLOTS SHALL BE CUT INTO THE PLANED SURFACE TO A DEPTH OF 3" PRIOR TO THE OVERLAY. LOOP DETECTORS MAY BE INSTALLED THROUGH FINISHED RIDING SURFACE AS SPECIFIED IN CONTRACT DOCUMENTS. SAW SLOTS IN FINAL RIDING SURFACE SHALL HAVE A 4" MINIMUM AND 4.5" MAXIMUM DEPTH.
- IN EXISTING ASPHALT CONCRETE ROADWAYS WHICH ARE NOT TO BE RESURFACED AS PART OF THE PROJECT, SAW SLOTS SHALL BE CUT INTO THE EXISTING SURFACE TO A DEPTH OF 4".

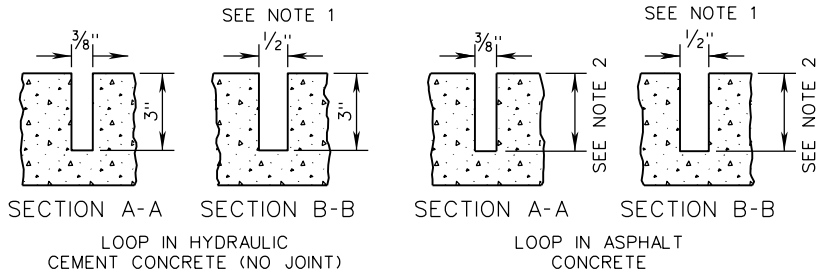

TYPICAL SAW SLOT DETAIL

DEPTH OF SAW SLOT SHALL BE MEASURED FROM PAVEMENT SURFACE AT TIME OF INSTALLATION. NOT NECESSARILY FINISHED GRADE.

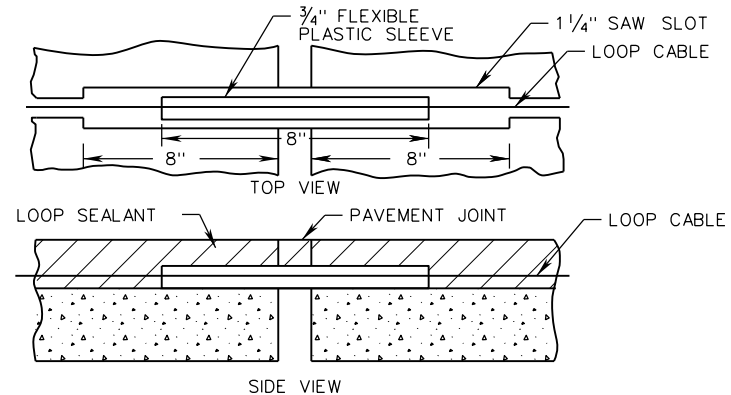

INSTALLATION OF LOOP CABLE ACROSS HYDRAULIC CEMENT CONCRETE PAVEMENT JOINTS



ROAD AND BRIDGE STANDARDS

SHEET 1 OF 3

REVISION DATE

1315.10

02/16

A COPY OF THE ORIGINAL SEALED AND SIGNED DRAWING IS ON FILE IN THE CENTRAL OFFICE.

LOOP DETECTOR

INSTALLATION DETAIL

VIRGINIA DEPARTMENT OF TRANSPORTATION

SPECIFICATION REFERENCE

703