

**NOTES:**

1. BARRIER DELINEATOR IS TO BE SPACED IN ACCORDANCE WITH SECTION 702 OF THE ROAD AND BRIDGE SPECIFICATIONS AND THE BARRIER VERTICAL PANELS ARE TO BE SPACED IN ACCORDANCE WITH THE VIRGINIA WORK AREA PROTECTION MANUAL.
2. REFLECTIVE SURFACE, IN ALL INSTANCES, ARE TO BE FACING ONCOMING TRAFFIC.
3. COST OF BARRIER DELINEATOR AND BARRIER VERTICAL PANELS ARE TO BE INCLUDED IN PRICE BID PER LINEAR FOOT OF BARRIER SERVICE.
4. ANCHOR BOLTS SHALL BE INSTALLED ON TRAFFIC SIDE.
5. CONCRETE 4000 PSI. (MIN.)
6. WELDED WIRE FABRIC MAY BE ONE SHEET BENT TO FIT CONFIGURATION OR TWO SEPARATE SHEETS, ONE ON EACH FACE.
7. AFTER REMOVING TEMPORARY BARRIER, CUT  $\frac{7}{8}$ "  $\emptyset$  BOLT OR THREADED ROD AS LOW AS PRACTICAL BELOW ROADWAY SURFACE AND FILL RECESS WITH EPOXY BONDING COMPOUND EP-4 (DETAIL "A") OR REMOVE  $\frac{7}{8}$ "  $\emptyset$  BOLT OR THREADED ROD AND FILL HOLE WITH GROUT BONDED WITH EPOXY BONDING COMPOUND EP-4, (DETAIL "A").
8. FOR POSITIVE CONNECTION DETAILS AND DIMENSIONS SEE STANDARD MB-INS.

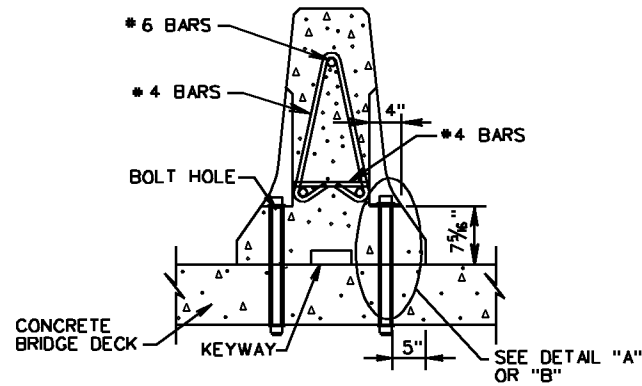

**SECTION B-B  
(ANCHOR BOLT)**  
BOLT DOWN SIDE ADJACENT TO TRAFFIC

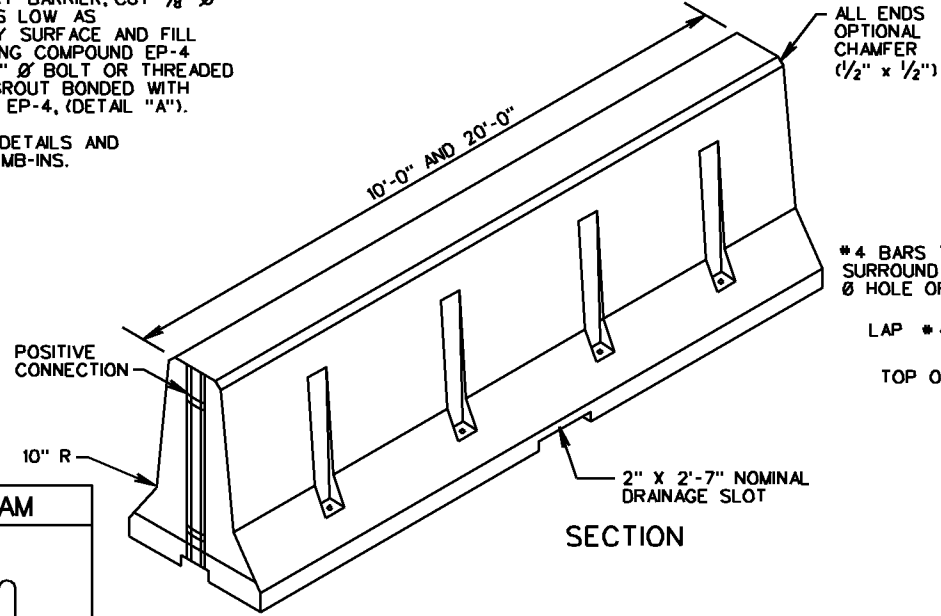

**SECTION**

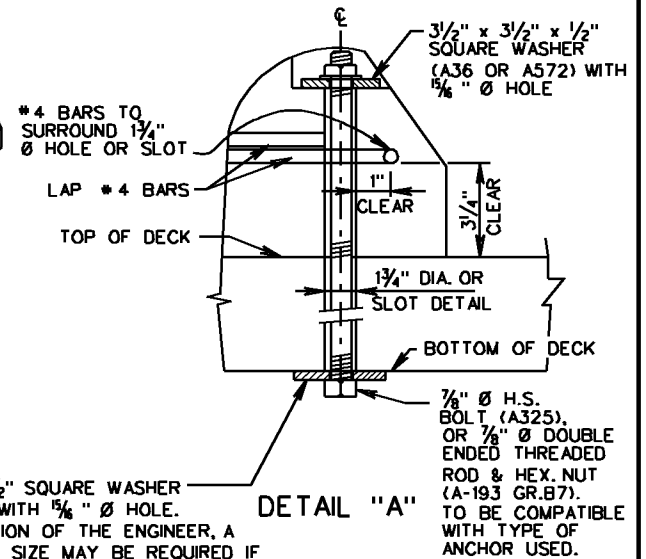

**DETAIL "A"**

3/2" x 3/2" x 1/2" SQUARE WASHER (A36 OR A572) WITH 5/8"  $\emptyset$  HOLE. AT THE DISCRETION OF THE ENGINEER, A LARGER WASHER SIZE MAY BE REQUIRED IF SPALLING IS EVIDENT AT BOTTOM OF DECK. TO PREVENT OR MINIMIZE SPALLING, PREDRILLING A PILOT HOLE USING A SMALLER DIAMETER DRILL BIT IS REQUIRED.

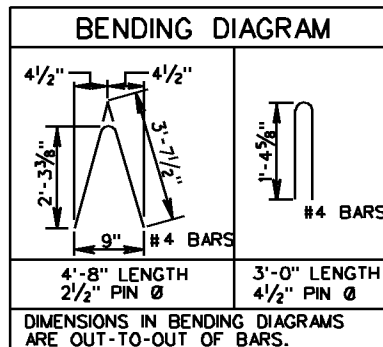

4'-8" LENGTH 2 1/2" PIN $\emptyset$	3'-0" LENGTH 4 1/2" PIN $\emptyset$
DIMENSIONS IN BENDING DIAGRAMS ARE OUT-TO-OUT OF BARS.	

SPECIFICATION REFERENCE
105 512

**TRAFFIC BARRIER SERVICE CONCRETE PARAPET  
(DOUBLE FACE)**

(FOR TEMPORARY INSTALLATION ON BRIDGE DECK EXTERIOR)

VIRGINIA DEPARTMENT OF TRANSPORTATION



ROAD AND BRIDGE STANDARDS

REVISION DATE	SHEET 2 OF 3
01/09	502.14