

- NOTES:**
1. A SECOND RAIL IS REQ'D. WHERE THE DISTANCE BETWEEN THE GROUND AND BOTTOM OF THE TOP RAIL EXCEEDS 18" (UP TO THE POINT WHERE THE RAIL CROSSES THE DITCH LINE). THE DOUBLE RAIL WILL EXTEND TO POST #3.
 2. MAXIMUM DISTANCE BETWEEN BOTTOM OF THE LOWER W-BEAM RAIL AND GROUND LINE IS 18". WHEN DOUBLE RAIL IS REQ'D., TAPER BOTH W-BEAM RAILS TO MAINTAIN THE 18" DISTANCE FROM THE GROUND.
 3. BOTH W-BEAM RAILS TO BE 1'-0" BELOW FINISHED GRADE AT POST #1 (8'-0" OFFSET).
 4. A 8'-0" LONG POST MUST BE USED WHEN UPPER AND LOWER W-BEAM RAILS ARE REQUIRED. FROM THE BEGINNING OF THE LOWER RAIL THROUGH POST #3.
 5. STANDARD GR-6 TERMINAL TREATMENT MAY BE USED AT THE RUN-ON END OF DIVIDED HIGHWAYS (LEFT AND RIGHT OF TRAFFIC) AND AT THE RUN-ON AND RUN-OFF ENDS ON UNDIVIDED HIGHWAYS.
 6. ALL POST SPACING 6'-3" C-C UNLESS OTHERWISE NOTED. THE POST MAY BE W6 X 8.5 STEEL OR 6 X 8 WOOD EXCEPT THE LAST 3 TERMINAL POSTS MUST BE W6 X 8.5 STEEL.
 7. FOR SECTIONS D-D & E-E, AND END ANCHORAGE DETAILS SEE SHEET 501.10.
 8. ALL TERMINAL RUN-ON OR RUN-OFF INSTALLATIONS SHALL BE INSTALLED WITH RAILS LAPPED IN THE DIRECTION OF ADJACENT TRAFFIC.
 9. IF THE BACKSLOPE IS ROCK AND 1:1 OR STEEPER, THE W-BEAM MAY BE ANCHORED PER SOLID ROCK CUT INSTALLATION (DETAIL F).

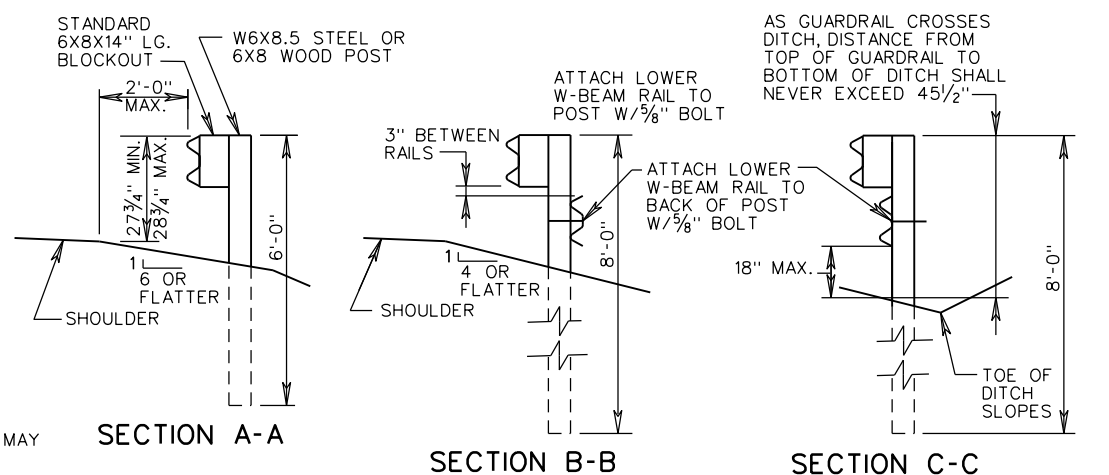

SPECIFICATION REFERENCE
221 505

A COPY OF THE ORIGINAL SEALED AND SIGNED DRAWING IS ON FILE IN THE CENTRAL OFFICE.

TERMINAL TREATMENT FOR W-BEAM GUARDRAIL

VIRGINIA DEPARTMENT OF TRANSPORTATION

VDOT	
ROAD AND BRIDGE STANDARDS	
REVISION DATE	SHEET 1 OF 2
7/12	501.09