

XJ-1

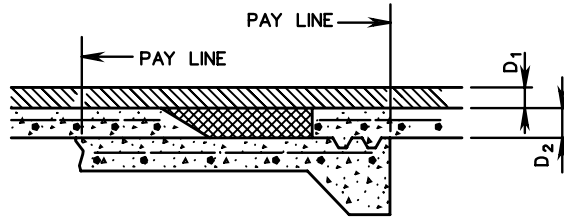

D₁ = DEPTH OF ASPHALT TOP USED ON APPROACHES
 D₂ = DEPTH OF CONCRETE BASE USED ON APPROACHES

VIEW (A)

USED WITH CONCRETE BASE WITH ASPHALT CONCRETE SURFACE

NOTE:

BRIDGE APPROACH EXPANSION JOINT INCLUDING SUB-SLAB IS TO TERMINATE AT EDGE OF THROUGH PAVEMENT.

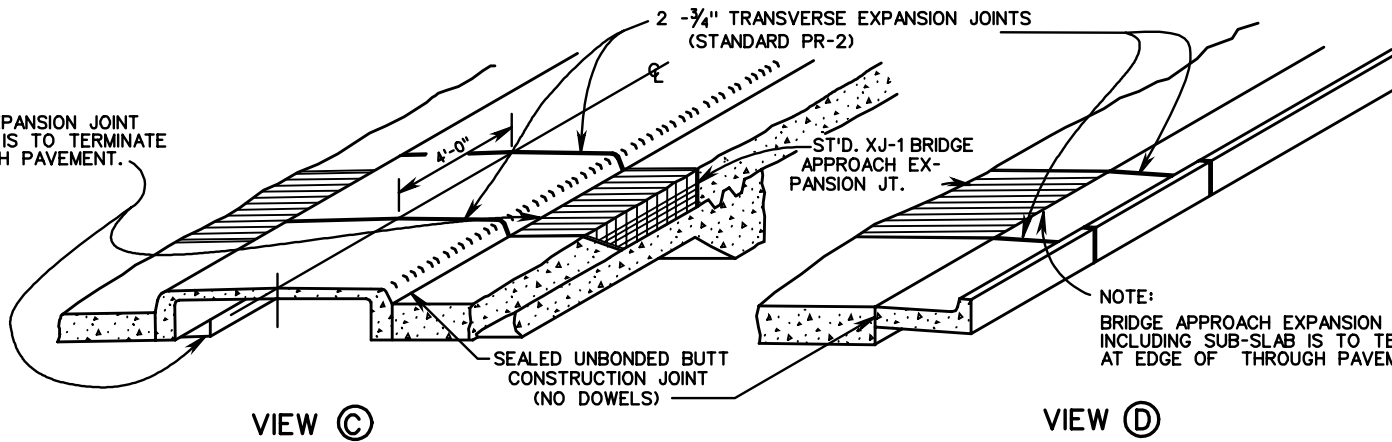

VIEW (C)

USED ADJACENT TO RAISED MEDIAN

VIEW (D)

USED ADJACENT TO CURB OR COMBINATION CURB AND GUTTER

NOTES:

ALL CONSTRUCTION FEATURES TO BE IN ACCORDANCE WITH SHEET 1 OF 2.
 IF CONCRETE PAVEMENT IS USED ADJACENT TO CONCRETE PAVEMENT WITH ASPHALT CONCRETE SURFACE, THE JOINT IS TO CONTINUE ACROSS ENTIRE WIDTH IN ACCORDANCE WITH SHEET 1 OF 2 AND VIEW A.
 IF CONCRETE PAVEMENT IS USED ADJACENT TO FLEXIBLE PAVEMENT THE JOINT IS TO EXTEND THROUGH RIGID PAVEMENT ONLY.



ROAD AND BRIDGE STANDARDS

SHEET 2 OF 2

REVISION DATE

302.02

**BRIDGE APPROACH EXPANSION JOINT
 (INSTALLATION CRITERIA)**

VIRGINIA DEPARTMENT OF TRANSPORTATION

SPECIFICATION REFERENCE

316