

SSP-VIA

**NOTES:**

1. FOUNDATION LOCATIONS SHALL BE APPROVED BY ENGINEER PRIOR TO INSTALLATION IN ACCORDANCE WITH SECTION 700.
2. MINIMUM VERTICAL CLEARANCE (DISTANCE BETWEEN BOTTOM OF SIGN PANEL AND FINISHED GRADE BENEATH THE PANEL) SHALL BE 7 FEET FOR ANY PORTION OF THE SIGN WITHIN THE CLEAR ZONE. THIS MINIMUM VERTICAL CLEARANCE MAY BE REDUCED TO 5 FEET FOR EITHER OF THE FOLLOWING CONDITIONS:
  - WHEN SIGNS OR PORTIONS OF SIGNS ARE LOCATED MORE THAN 10 FEET UP A CUT SLOPE GREATER THAN 3:1, OR
  - WHEN THE SIGN IS LOCATED AT LEAST THE MINIMUM DISTANCE BEHIND CURB, BARRIER, OR GUARDRAIL AS PER NOTE 6.
3. SIGN PANEL SHALL BE DESIGNED IN ACCORDANCE WITH SPD-2, SPD-3 OR SPD-7.
4. THE VERTICAL T-BEAM SHALL BE 2"W X 2"D X 1/4" THICK STRUCTURAL ALUMINUM ALLOY 6061-T6 AT A MINIMUM LENGTH OF 6'-0" AND EXTENDED TO THE NEXT HORIZONTAL SUPPORT BAR ON THE SSP-VIA STRUCTURE.
5. THE T-BEAM SHALL BE ATTACHED TO THE SSP-VIA STRUCTURE BY THE FOLLOWING METHODS:
  - T-BEAM FOR THE SPD-2 SIGN PANEL SHALL BE ATTACHED BY USING A MINIMUM OF TWO POST CLIP BOLTS AT EACH CROSS MEMBER.
  - T-BEAM FOR THE SPD-3 SIGN PANEL SHALL BE ATTACHED BY USING TWO ASTM F593, ALLOY 304 STAINLESS STEEL 3/8" DIAMETER-16 UNC BOLT WITH STAINLESS STEEL NUT AND FLAT WASHER AT ZEE BAR CONNECTIONS AND TWO POST CLAMP AND BOLT AT EACH TEE-BAR CONNECTION.
  - T-BEAM FOR THE SPD-7 SIGN PANEL SHALL BE ATTACHED BY USING A MINIMUM OF TWO POST CLAMP AND POST CLAMP BOLTS AT EACH STIFFENER.
6. THE LATERAL CLEARANCE TO THE SIGN PANEL SHALL BE A MINIMUM OF 2 FEET FROM THE FACE OF CURB OR 4 FEET FROM FACE OF BARRIER, IF PRESENT. UNLESS OTHERWISE APPROVED BY THE ENGINEER, SIGNS PLACED BEHIND GUARDRAIL SHALL BE LOCATED SUCH THAT THE NEAR SIDE EDGE OF THE SIGN PANEL IS OUTSIDE OF THE GUARDRAIL DEFLECTION DISTANCE.

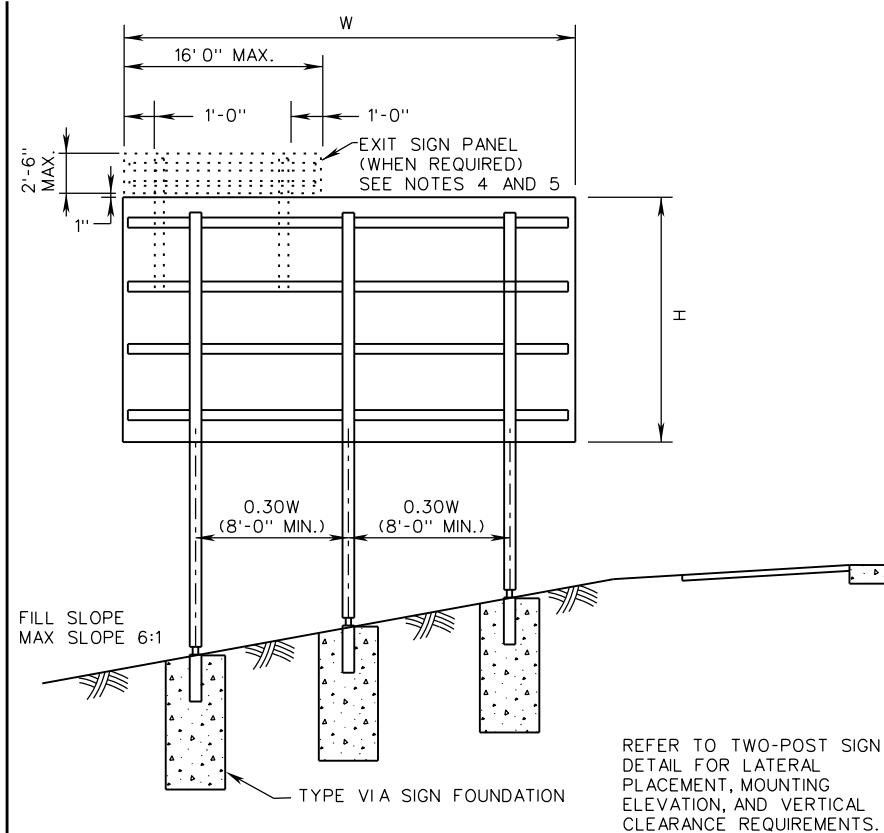
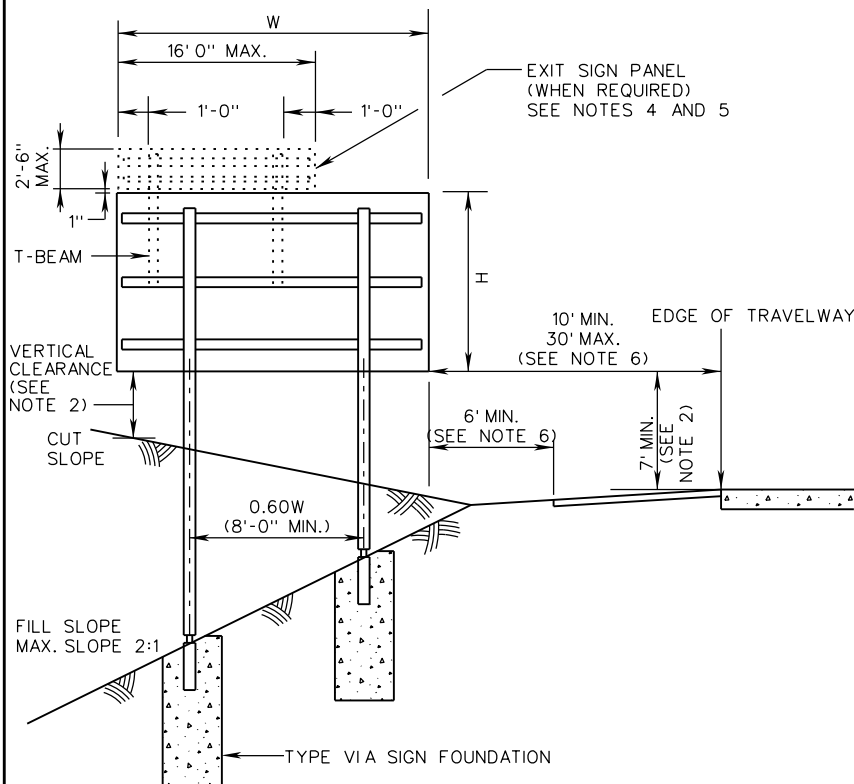

<b>VDOT</b>	
ROAD AND BRIDGE STANDARDS	
SHEET 1 OF 10	REVISION DATE
1323.10	01/15

A COPY OF THE ORIGINAL SEALED AND SIGNED DRAWING IS ON FILE IN THE CENTRAL OFFICE.

## INTERSTATE SIGN STRUCTURE

### INSTALLATION DETAILS

VIRGINIA DEPARTMENT OF TRANSPORTATION

SPECIFICATION REFERENCE
700