

NOTES:

AMOUNT OF PAVED DITCH REPLACED BY "ENERGY DISSIPATOR" TABULATED BY DEPTHS AS SHOWN IN STANDARD PG-2A.

THIS ITEM MAY BE PRECAST OR CAST IN PLACE.

CONCRETE TO BE CLASS A3 IF CAST IN PLACE.

FOR PRECAST SEE SHEET 111.02.

THE 2:1 DESIGN MAY BE USED ON EITHER 1/2:1 OR 2:1 SLOPES.

EG-1-ENERGY DISSIPATOR WITHOUT GRATE.
EG-1A-ENERGY DISSIPATOR WITH GRATE.

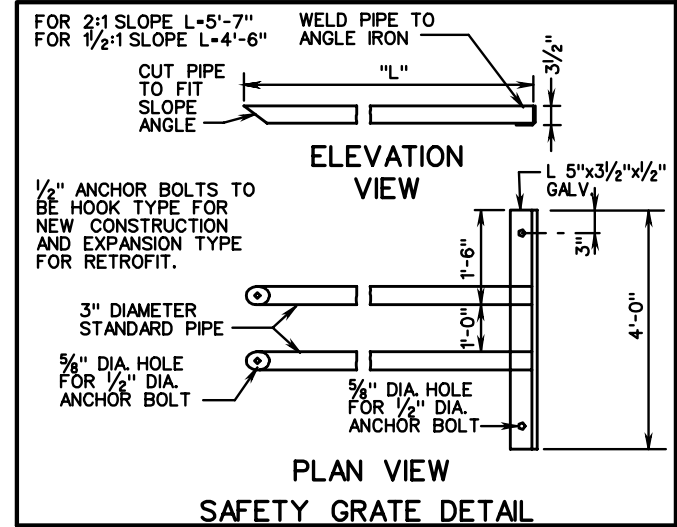
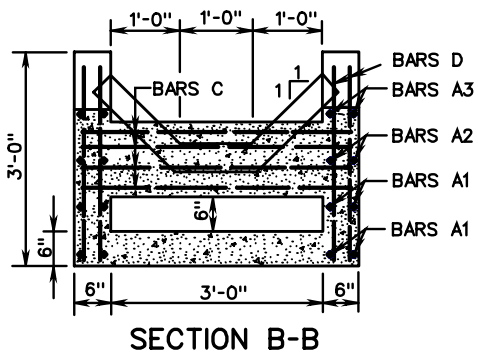
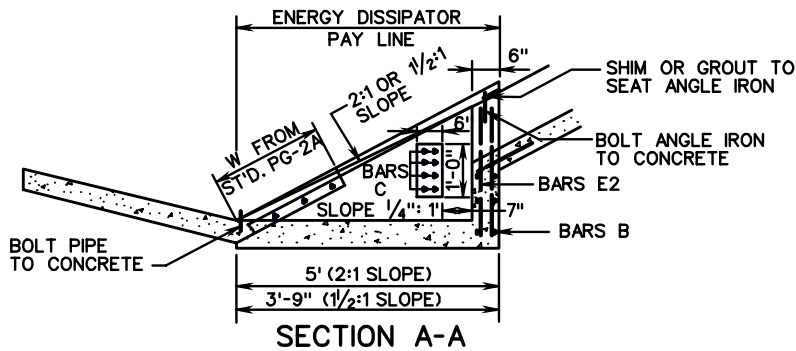

SCHEDULE OF REINFORCING STEEL						
MARK	NO.	LENGTH		SIZE	SPACING C-C	SHAPE
		2:1	1 1/2:1			
A1	8	2'-10"	2'-10"	# 3	8"	STRAIGHT
A2	4	2'-6 1/4"	1'-10"	# 3	8"	STRAIGHT
A3	4	1'-0 3/4"	0'-10"	# 3	8"	STRAIGHT
B	6	3'-9"	3'-9"	# 3	8"	STRAIGHT
C	8	3'-8"	3'-8"	# 4	2 1/2"	STRAIGHT
D1	4	1'-2 1/2"	0'-8"	# 3	8"	STRAIGHT
D2	4	1'-6 1/2"	1'-1 1/2"	# 3	8"	STRAIGHT
D3	4	1'-10 1/2"	1'-7"	# 3	8"	STRAIGHT
D4	4	2'-2 1/2"	2'-0 1/2"	# 3	8"	STRAIGHT
D5	4	2'-6 1/2"	2'-6"	# 3	8"	STRAIGHT
E1	4	1'-11 1/2"	1'-11 1/2"	# 3	8"	STRAIGHT
E2	4	1'-5 1/2"	1'-5 1/2"	# 3	8"	STRAIGHT

APPROXIMATE QUANTITIES			
		CONCRETE	REINFORCING STEEL
		CU. YDS.	LBS.
ENERGY DISSIPATOR	2:1	0.7479	61.20
	1/2:1	0.5921	57.63

SPECIFICATION REFERENCE
502

STANDARD ENERGY DISSIPATOR

FOR USE WITH PAVED FLUMES

VIRGINIA DEPARTMENT OF TRANSPORTATION



ROAD AND BRIDGE STANDARDS

REVISION DATE SHEET 1 OF 1

111.01