

PG-7

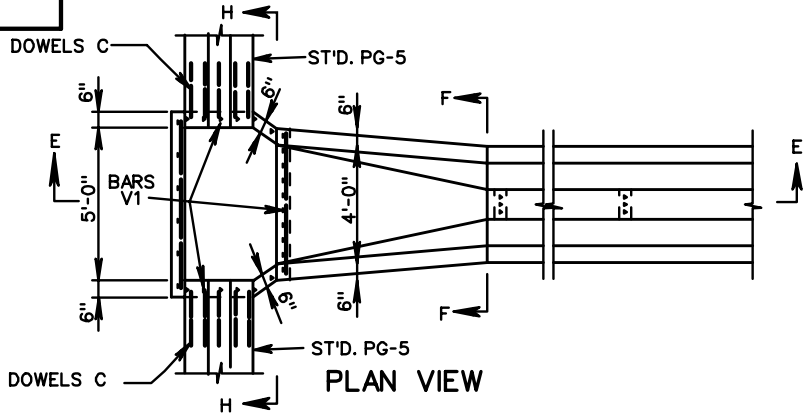

PLAN VIEW

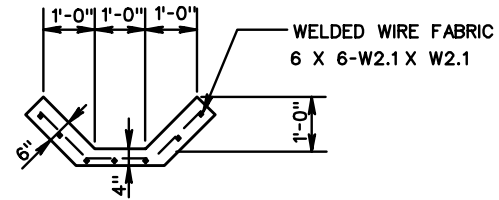

SECTION F-F

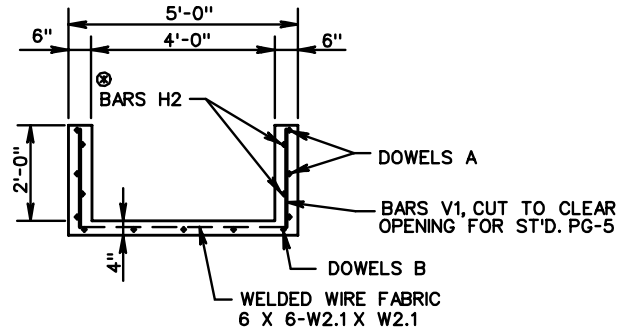

SECTION H-H

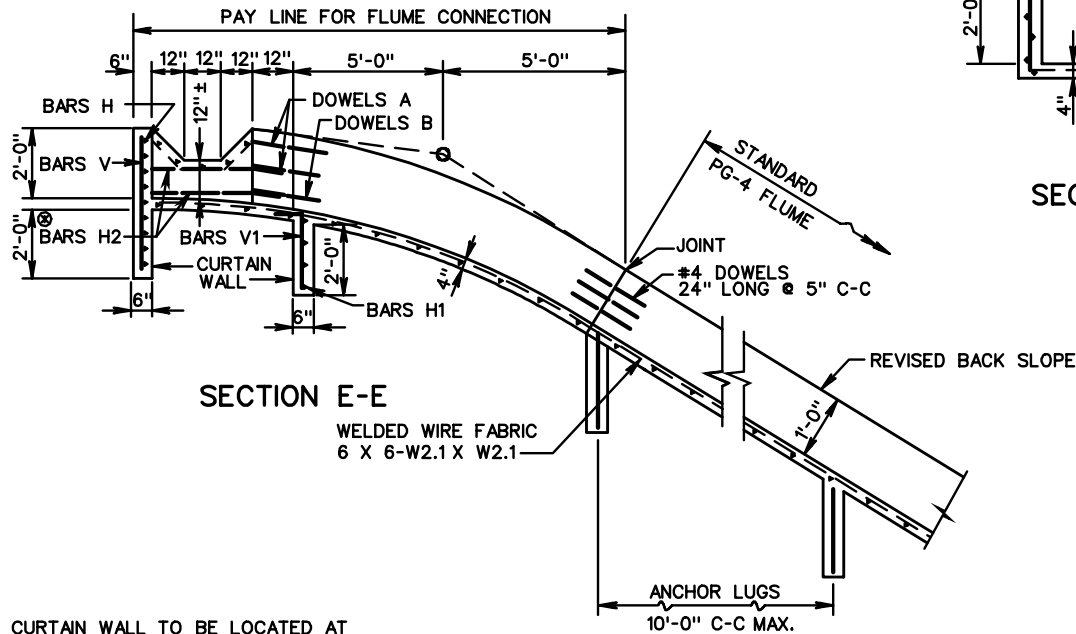

SECTION E-E

CURTAIN WALL TO BE LOCATED AT BEGINNING AND END OF ALL FLUMES AND ON THE LOWER END OF EACH JOINT.

PRICE BID PER EACH TO INCLUDE DOWELS, WELDED WIRE FABRIC, REINFORCING STEEL, ANCHOR LUGS AND CURTAIN WALL, AND CLASS A-3 CONC.

⊗ FIELD CUT BARS V1 & BARS H2 TO CLEAR OPENING FOR ST'D. PG-5

REINFORCING STEEL SCHEDULE				
MARK	SIZE	NO.	SPACING	LENGTH
H	#3	9	6"	5'-8"
H1	#3	4	6"	4'-8"
H2	#3	6	6"	5'-3"
V	#4	6	12"	4'-0"
V1	#4	24	6"	3'-0"
DOWELS A	#4	12	10"	2'-0"
DOWELS B	#4	6	10"	2'-0"
DOWELS C	#4	10	10"	1'-0"
W.W.F.	8GA			83 S.F.

BENDING DIAGRAM

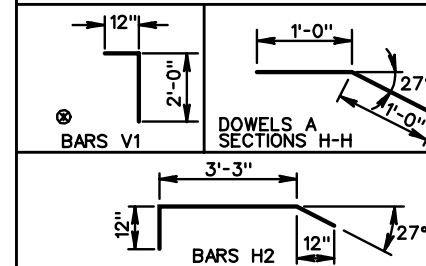

APPROXIMATE QUANTITIES	
REINFORCING STEEL 132.9 LBS.	CLASS A3 CONC. 1.7 CU. YDS.



ROAD AND BRIDGE STANDARDS

SHEET 1 OF 1

REVISION DATE

109.06

DITCH FLUME CONNECTOR

VIRGINIA DEPARTMENT OF TRANSPORTATION

SPECIFICATION REFERENCE

502