

SECTION 1400

UTILITIES

STANDARD

THIS PAGE INTENTIONALLY LEFT BLANK



ROAD AND BRIDGE STANDARDS

SHEET 1 OF 1

REVISION DATE

TITLE

VIRGINIA DEPARTMENT OF TRANSPORTATION

SPECIFICATION
REFERENCE

STANDARD	TITLE	PAGE
UB-1	UTILITY BEDDING AND PROTECTION	1401.01
RB-1	REACTION BLOCKING	1402.01
	REACTION BLOCKING	1402.02
	REACTION BLOCK	1402.03
VO-1	VERTICAL OFFSET	1403.01
EP-1	CONCRETE OR STEEL ENCASEMENT PIPE	1404.01
LD-1	LEAK DETECTOR	1405.01
VB-1	VALVE BOX AND VALVE MANHOLE	1406.01
VM-1	VALVE BOX AND VALVE MANHOLE	1406.02
FH-1	FIRE HYDRANT	1407.01
WM-1	WATER METER AND BOX	1408.01
BOV-1	BLOW-OFF VALVE AND BOX	1409.01
ARV-1	AIR RELEASE VALVE AND BOX	1410.01
SMH-1	SANITARY SEWER MANHOLE	1411.01
SMH-1	SANITARY SEWER MANHOLE	1411.02
F&C-1	WATER AND SANITARY SEWER FACILITIES	1412.01
SCO-1	SEWER CLEANOUT	1413.01

**INDEX OF SHEETS
SECTION 1400-UTILITIES**

VIRGINIA DEPARTMENT OF TRANSPORTATION



ROAD AND BRIDGE STANDARDS

REVISION DATE

SHEET 1 OF 1

1400.01

THIS PAGE INTENTIONALLY LEFT BLANK



ROAD AND BRIDGE STANDARDS

SHEET 1 OF 1

REVISION DATE

1400.02

SPECIFICATION
REFERENCE

VIRGINIA DEPARTMENT OF TRANSPORTATION

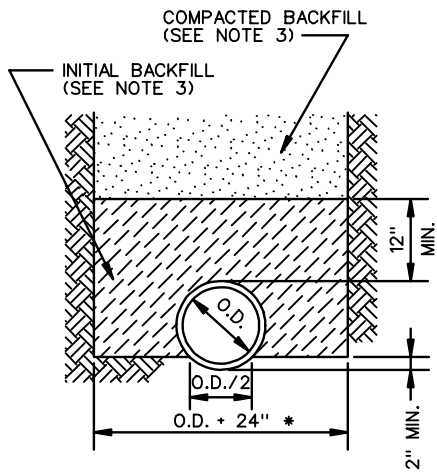

TYPE 1

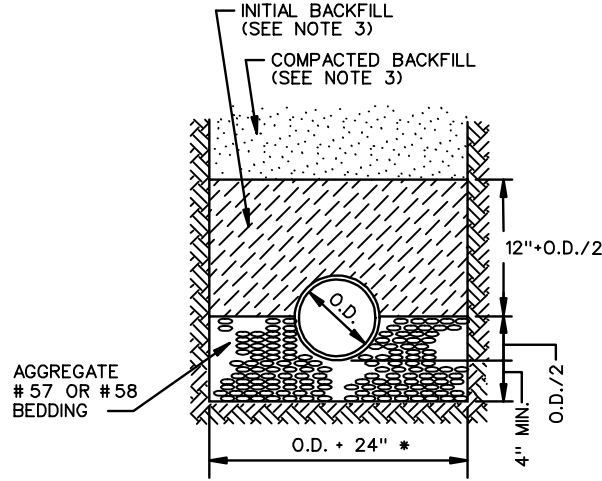

TYPE 2

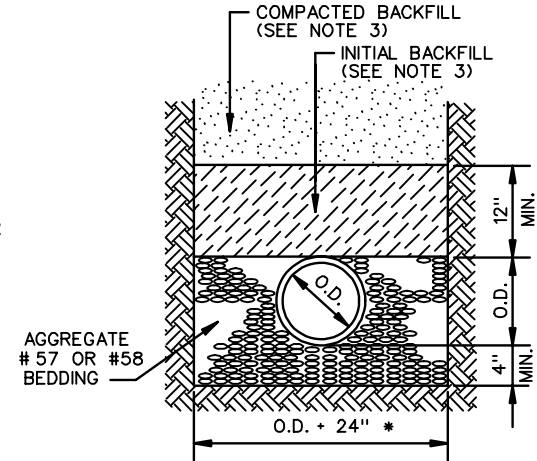

TYPE 3

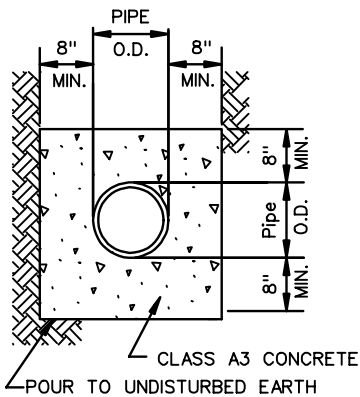

CONCRETE ENCASEMENT

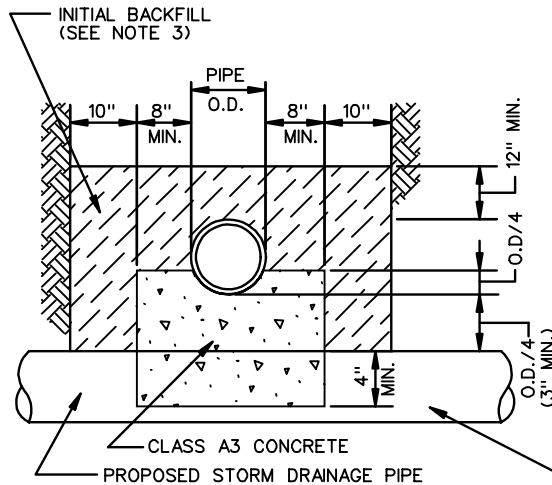

CONCRETE CRADLE

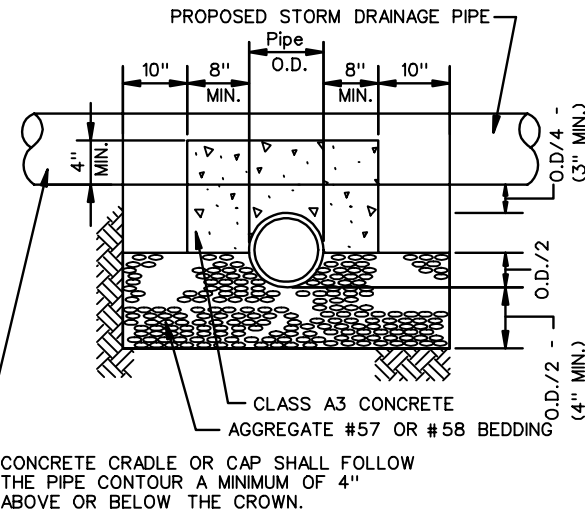

CONCRETE CAP

NOTES:

1. WHERE THE TRENCH BOTTOM IS IN ROCK, IT SHALL BE EXCAVATED TO A MINIMUM OF 8" BELOW THE BOTTOM OF THE PIPE BACKFILLED WITH BEDDING MATERIAL.
2. WHERE PIPE FOUNDATIONS ARE YIELDING, PIPE SHALL BE BEDDED ON A MINIMUM OF 8" BEDDING MATERIAL.

3. INITIAL AND COMPACTED BACKFILL SHALL MEET THE REQUIREMENTS OF SECTION 520.03 OF THE VDOT SPECIFICATIONS. CRUSHED GLASS CONFORMING TO THE SIZE REQUIREMENTS FOR CRUSHER RUN AGGREGATE SIZE 25 OR 26 AND MEETING THE REQUIREMENTS OF SECTION 520.03 OF THE VDOT SPECIFICATION MAY BE USED AS BACKFILL MATERIAL.

* FOR PIPE LESS THAN 12" THE TRENCH WIDTH MAY BE 36" MAXIMUM.

SPECIFICATION REFERENCE
520

UTILITY BEDDING AND PROTECTION
(WATER AND SANITARY SEWER FACILITIES)

VIRGINIA DEPARTMENT OF TRANSPORTATION



ROAD AND BRIDGE STANDARDS

REVISION DATE SHEET 1 OF 1

1401.01

THIS PAGE INTENTIONALLY LEFT BLANK



ROAD AND BRIDGE STANDARDS

SHEET 1 OF 1

REVISION DATE

1401.02

SPECIFICATION
REFERENCE

VIRGINIA DEPARTMENT OF TRANSPORTATION

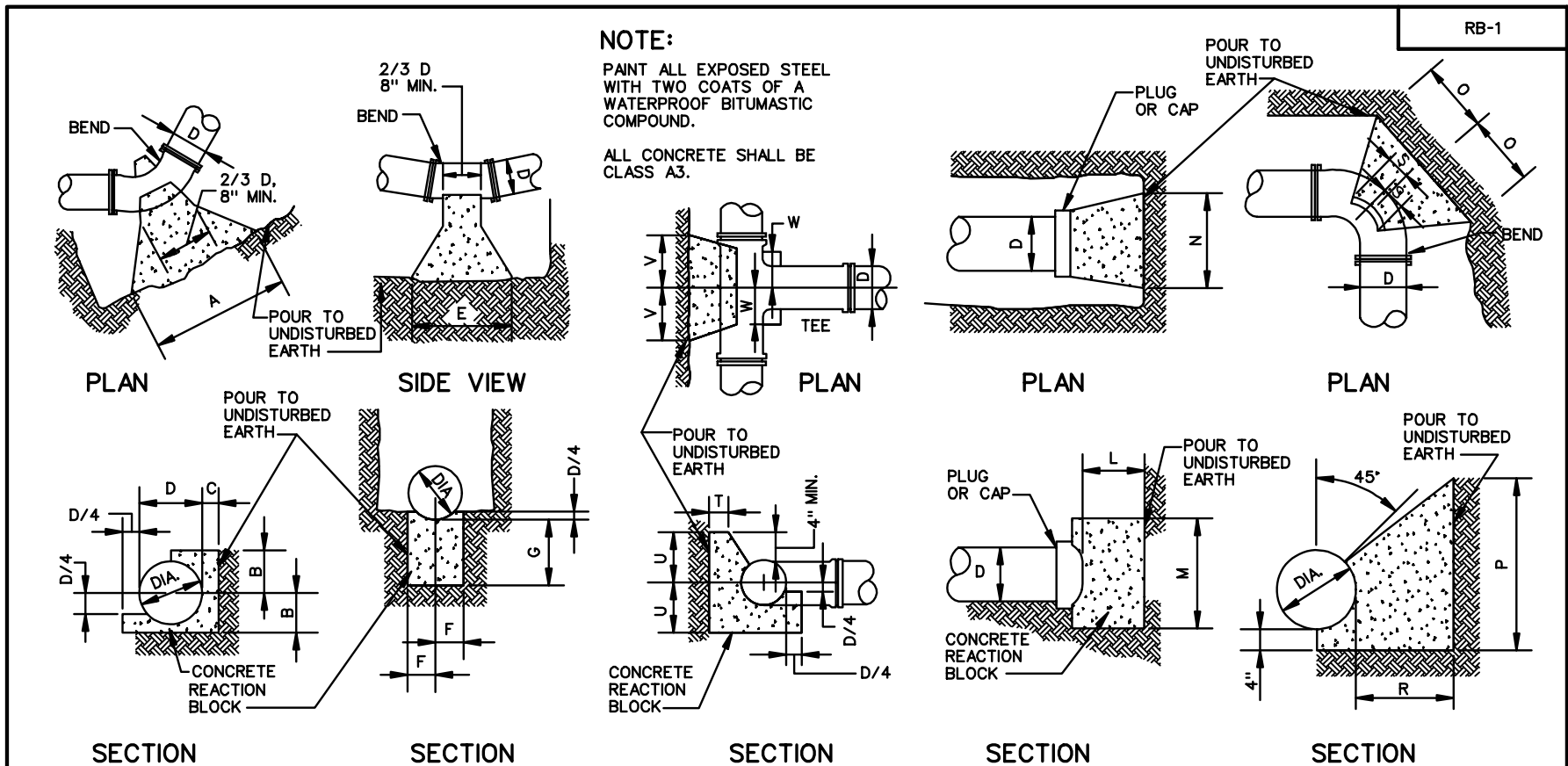

NOTE:
 PAINT ALL EXPOSED STEEL WITH TWO COATS OF A WATERPROOF BITUMASTIC COMPOUND.
 ALL CONCRETE SHALL BE CLASS A3.

HORIZONTAL BENDS
11 1/4° - 45°

UPPER VERTICAL BENDS

TEES

PLUGS

HORIZONTAL BENDS 90°

DIA.	HORIZONTAL BENDS						UPPER VERTICAL BENDS						PLUGS			HORIZONTAL BENDS					TEE									
	11 1/4°			22 1/2°			45°			11 1/4°			22 1/2°			45°			L	M	N	90°					BRANCH			
	A	B	C	A	B	C	A	B	C	E	F	G	E	F	G	E	F	G	L	M	N	O	P	R	S	T	U	V	W	
4"	.50	.58	.75	.75	.58	.75	1.25	.58	.75	.50	.58	.58	.75	.58	.58	1.25	.58	.58	.50	1.17	1.50	1.17	1.17	1.67	.42	.75	.67	.75	.50	
6"	.50	.58	.75	.75	.58	.75	1.25	.58	.75	.50	.58	.58	.75	.58	.58	1.25	.58	.58	.50	1.17	1.50	1.17	1.17	1.67	.42	.75	.67	.75	.50	
8"	.67	.67	.75	1.00	.67	.75	2.00	.67	.75	.67	.67	.58	1.00	.67	.67	2.08	.75	.83	.67	1.50	2.25	1.58	1.50	1.75	.50	.75	.83	1.00	.67	
10"	.83	.75	.75	1.50	.75	.83	2.50	.75	.92	.83	.75	.67	1.50	.83	.67	2.08	.75	.83	.67	2.00	2.50	1.67	2.08	1.75	.50	.83	1.00	1.25	.67	
12"	1.00	.83	.75	1.75	.92	.92	2.92	.92	1.17	1.00	.83	.67	1.75	.83	.67	2.50	.92	.92	.83	2.33	3.25	2.00	2.50	1.92	.58	1.00	1.25	1.42	.67	
16"	1.33	1.00	.75	2.33	1.00	1.17	3.67	1.25	1.42	1.33	1.00	.75	2.25	.83	.75	3.33	1.25	1.25	1.00	2.92	4.17	2.08	3.00	2.17	.83	1.17	1.67	1.83	.83	
20"	1.67	1.17	1.00	3.17	1.17	1.33	4.75	1.50	1.83	1.67	1.17	.83	3.00	1.17	1.00	4.17	1.50	1.50	1.33	3.75	5.17	3.50	3.83	2.83	1.00	1.33	2.08	2.25	1.17	
24"	2.00	1.33	1.00	4.00	1.33	1.50	6.08	1.67	1.92	2.00	1.33	1.00	3.50	1.33	1.00	5.00	1.75	1.75	1.67	4.33	6.25	4.67	4.00	3.00	1.00	1.50	2.50	2.67	1.33	
30"	2.50	1.50	1.08	5.00	1.58	1.75	7.95	2.00	3.08	2.50	1.58	1.08	4.17	1.58	1.08	6.25	2.25	2.25	2.00	5.42	7.42	5.75	5.00	3.83	1.17	1.75	3.08	3.92	1.83	
36"	3.00	1.92	1.17	5.75	2.00	2.00	8.92	2.50	3.33	3.00	1.58	1.17	5.33	2.00	1.17	7.50	2.50	2.67	2.00	6.50	9.00	6.83	6.00	4.83	1.17	2.00	3.75	3.92	1.83	

SPECIFICATION REFERENCE

REACTION BLOCKING
 (WATER AND SANITARY SEWER FACILITIES)

VIRGINIA DEPARTMENT OF TRANSPORTATION



ROAD AND BRIDGE STANDARDS

REVISION DATE

SHEET 1 OF 3

1402.01

TEES TURNED UP				
BRANCH SIZE				
D	NN	NN	PP	RR
DIA.	11 1/4° 22 1/2°	45°	11 1/4° 22 1/2° 45°	11 1/4° 22 1/2° 45°
4"	3.00	2.50	2.50	2.50
6"	3.00	2.50	2.50	2.50
8"	3.00	2.50	2.50	2.50
10"	3.00	2.50	2.50	2.67
12"	4.00	3.00	2.50	2.83

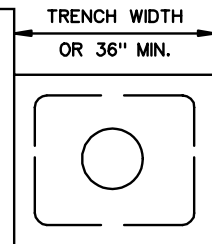

SECTION A-A

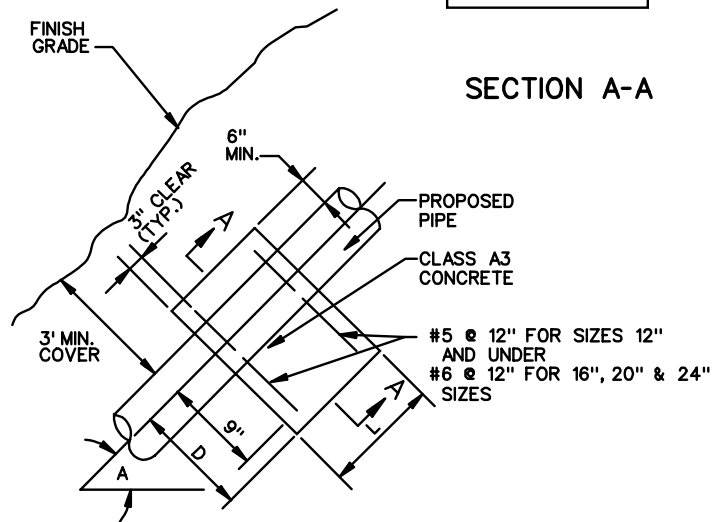

REACTION BLOCK - STRAIGHT SLOPING PIPE							
SIZE	4"	6"	8"	12"	16"	20"	24"
"D"	12"	15"	15"	18"	21"	24"	27"
"L"	18"	21"	24"	27"	30"	33"	36"

NOTE:

THE STRAIGHT RUN PIPE SHALL BE PROVIDED WITH ANCHOR BLOCKS SPACED THUS:

ANGLE "A"	ANCHOR BLOCKS NOT NEEDED
0° - 10°	SPACING @ 100'
10° - 16°	SPACING @ 60'
16° - 20°	

**STRAIGHT PIPE
CONCRETE ANCHOR BLOCK**

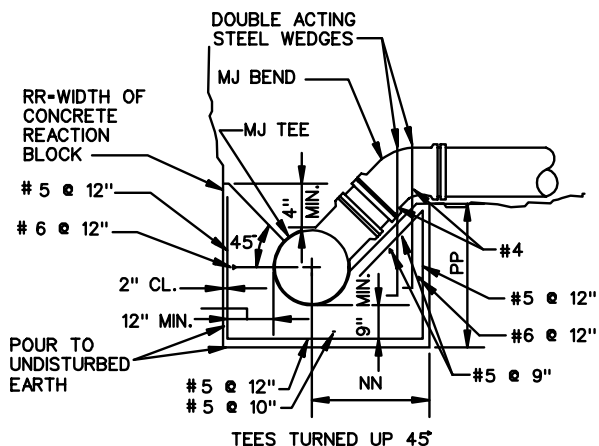

**STRAPPING DETAILS
FOR TEES TURNED UP**

SPECIFICATION
REFERENCE

**REACTION BLOCK
(WATER AND SANITARY SEWER FACILITIES)**

VIRGINIA DEPARTMENT OF TRANSPORTATION



ROAD AND BRIDGE STANDARDS

REVISION DATE SHEET 3 OF 3

1402.03

VO-1

SIZE (DIA. - INCHES)	4"	6"	8"	10"	12"	16"	18"	20"	24"
LENGTH ("L" - FEET)	12'	17'	22'	26'	31'	39'	43'	47'	55'

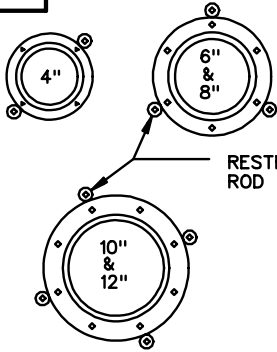

RESTRAINING ROD (TYP.)

SEE TABLE FOR 16" - 24"

PIPE SIZE	NUMBER OF BOLTS	NUMBER OF RODS
16"	12	6
18"	12	6
20"	14	6
24"	16	8

SEE NOTE 7 FOR REDUCTION IN NUMBER OF RODS REQUIRED.

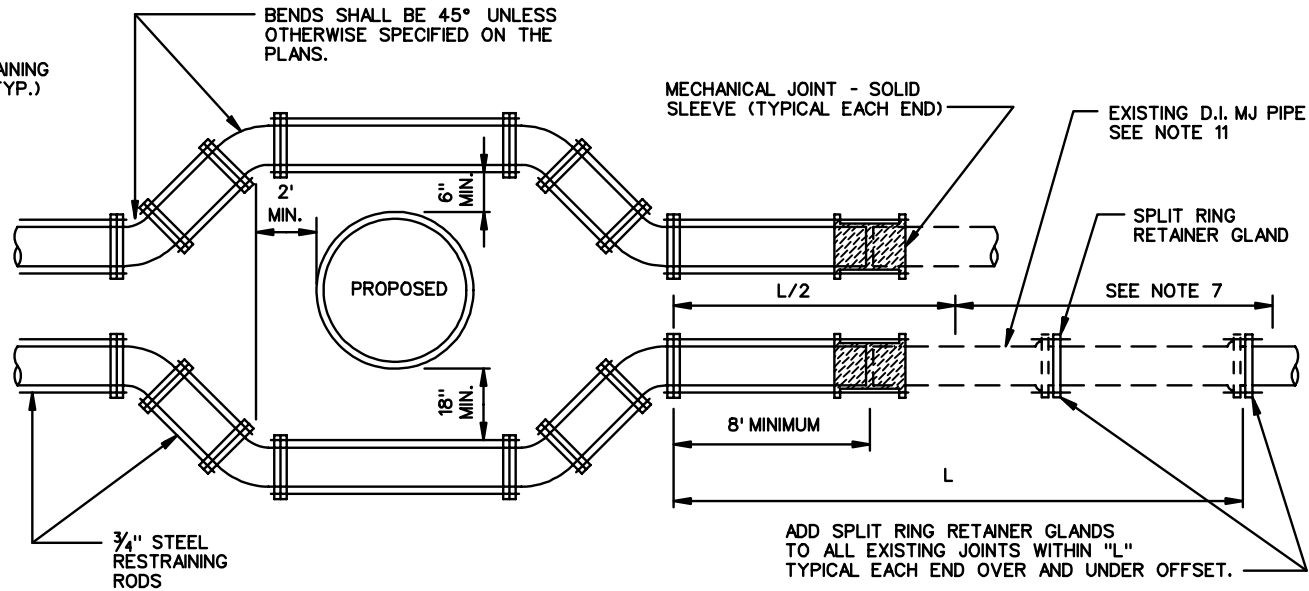

DESIGN CONDITIONS

PRESSURE - 150 PSI TYPE SOIL - SILT
 DEPTH OF COVER - 3 FEET ROD STRESS - 25,000 PSI

NOTES:

1. RETAINER GLANDS ARE REQUIRED AT EACH FITTING.
2. ALL PIPE AND FITTINGS SHALL BE DUCTILE IRON, MECHANICAL JOINT, CLASS 52 (MIN). WATER MAIN AND FITTINGS SHALL BE CEMENT MORTAR LINED.
3. FOR 12" AND SMALLER LINES, MECHANICAL JOINT OFFSET FITTINGS MAY BE USED IN LIEU OF THE 45° BENDS SHOWN SUBJECT TO THE APPROVAL OF THE ENGINEER. IF USED, THE OFFSETS MUST RESULT IN THE CLEARANCES SHOWN BEING MET OR EXCEEDED.
4. RODS MAY BE INSERTED THROUGH BOLT HOLES IN LIEU OF USING TIE-BOLTS. IF USED, KEEPER NUT & WASHER MUST BE INSTALLED BEHIND GLAND.
5. BOLT HOLES ARE SHOWN AS NORMALLY PROVIDED IN MECHANICAL JOINT FITTINGS, I.E. STRADDLING THE VERTICAL AXIS WHEN FITTING IS POSITIONED FOR A HORIZONTAL CHANGE OF DIRECTION. FITTINGS WITH BOLT HOLES OTHERWISE ORIENTED SHOULD NOT BE USED IN RODDED ASSEMBLIES.
6. TIE BOLTS AND THREADED RODS SHALL BE 3/4" WITH A MINIMUM YIELD STRENGTH OF 7550 POUNDS EACH. SPACE SYMMETRICALLY AROUND PIPE.
7. NUMBER OF RODS MAY BE REDUCED TO 50% OF THE NUMBER INDICATED AT L/2 FROM THE BEND AND BEYOND. TWO RODS MINIMUM REQUIRED PER JOINT.
8. ALL RODS AND FASTENERS SHALL BE GIVEN TWO COATS OF ASPHALTIC PAINT AFTER ASSEMBLY.
9. EXISTING C.I. PIPE SHALL BE REPLACED WITH AN 8' MINIMUM LENGTH OF D.I. PIPE AT BOTH ENDS OF THE OFFSET AND RETAINER GLANDS INSTALLED.
10. THE EXISTING PIPING SHALL HAVE ALL JOINTS WITHIN THE LENGTH "L" RESTRAINED BY ADDING A SPLIT RING RETAINER GLAND ("MEG-A-LUG" OR EQUAL) WITH BOLTS TO THE M.J. BELL.
11. LENGTH "L" IN FEET SHALL CONFORM TO THE TABLE ABOVE.
12. SPLIT RING RETAINER GLANDS ARE FOR USE ON DUCTILE IRON MECHANICAL JOINT PIPE ONLY. IF EXISTING PIPE IS ANY OTHER MATERIAL, REMOVE AND REPLACE WITH D.I. MECHANICAL JOINT PIPE FOR THE LENGTH "L" SPECIFIED.



ROAD AND BRIDGE STANDARDS

SHEET 1 OF 1

REVISION DATE

1403.01

**VERTICAL OFFSET
 (WATER AND SANITARY SEWER FACILITIES)**

VIRGINIA DEPARTMENT OF TRANSPORTATION

SPECIFICATION REFERENCE

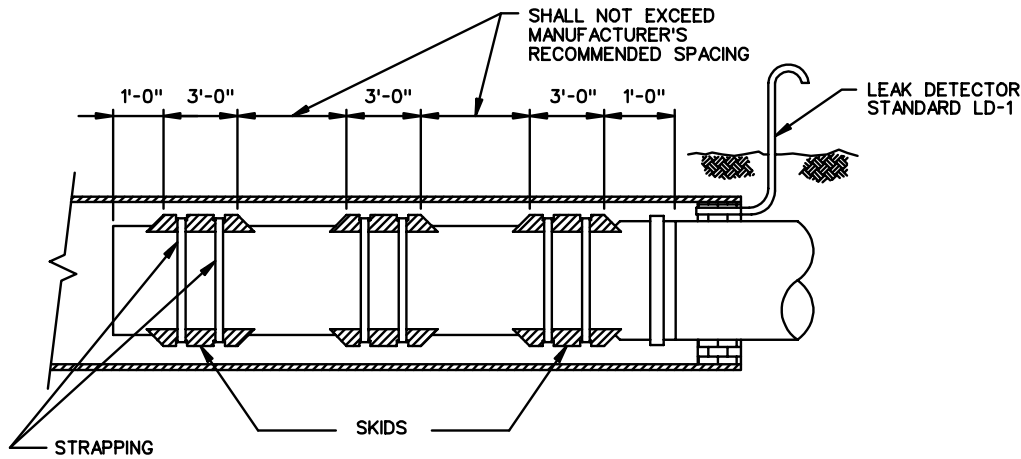

SECTION
ENCASEMENT PIPE WITH CARRIER PIPE

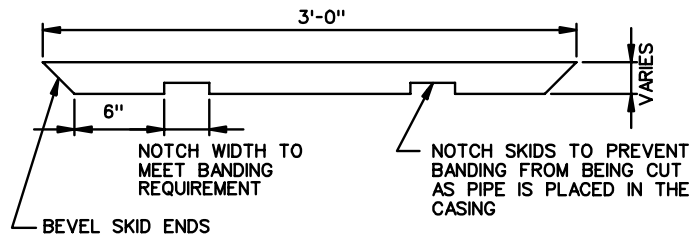

SKID

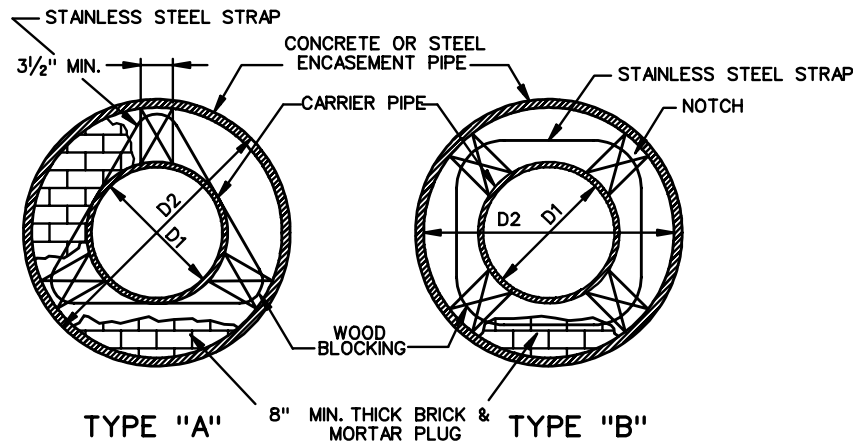

NOTES:

1. TIMBER SKIDS SHALL BE LOCUST, CYPRESS, PRESERVATIVE TREATED HARDWOOD, NEOPRENE, NYLON, PLASTIC OR OTHER MATERIAL OF HIGH ABRASION RESISTANCE AND A LOW FRICTION COEFFICIENT APPROVED BY THE ENGINEER. PRESERVATIVE FOR TIMBER SKIDS SHALL CONFORM TO SECTION 236 OF THE SPECIFICATIONS.
2. METAL STRAPS AND CLIPS HOLDING BLOCKING TO CARRIER PIPE SHALL BE STAINLESS STEEL WITH A MINIMUM CROSS SECTION OF 0.014 SQ. IN. STRAP SPACING SHALL BE A MINIMUM OF TWO (2) BANDS PER SKID LENGTH.
3. STEEL ENCASEMENT PIPE SHALL BE GRADE B AND SHALL CONFORM TO SECTION 232.02 (C)5 OF THE SPECIFICATIONS OR AS SPECIFIED
4. CARRIER PIPE SHALL BE PUSHED OR PULLED THROUGH THE ENCASEMENT PIPE SO THAT JOINTS ARE ALWAYS BEING COMPRESSED.
5. CARRIER PIPE SHALL BE WRAPPED WITH TAR PAPER AT MASONRY PLUG.
6. MASONRY PLUG SHALL BE WATERTIGHT.
7. CONCRETE PIPE FOR H-20 LIVE LOAD AS PER STANDARD PC-1.
8. ENCASEMENT PIPE SHALL BE BEDDED IN ACCORDANCE WITH STANDARD PB-1.

SPECIFICATION
REFERENCE

232
236

CONCRETE OR STEEL ENCASEMENT PIPE

VIRGINIA DEPARTMENT OF TRANSPORTATION

VDOT

ROAD AND BRIDGE STANDARDS

REVISION DATE

SHEET 1 OF 1

1404.01

LD-1

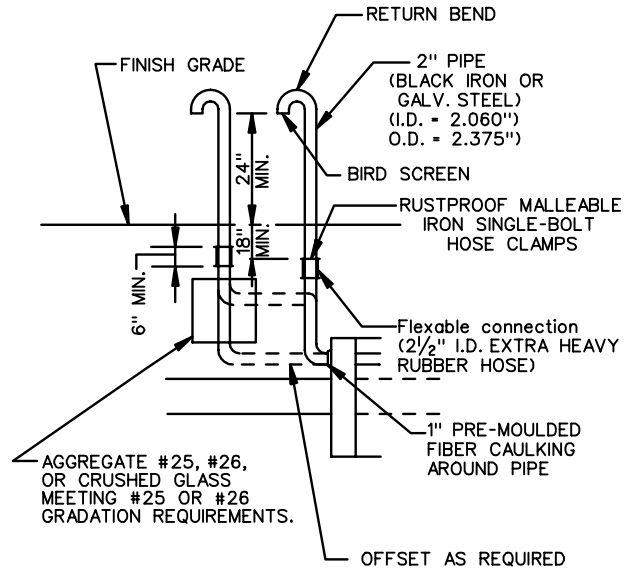

Notes:

WRAP CONNECTION IN POLYETHELENE
AND PLASTER WITH ROOFING CEMENT
OR ASPHALTIC MATERIAL.

STANDARD LEAK DETECTOR

LD-1



ROAD AND BRIDGE STANDARDS

LEAK DETECTOR

SPECIFICATION
REFERENCE

SHEET 1 OF 1

REVISION DATE

1405.01

VIRGINIA DEPARTMENT OF TRANSPORTATION

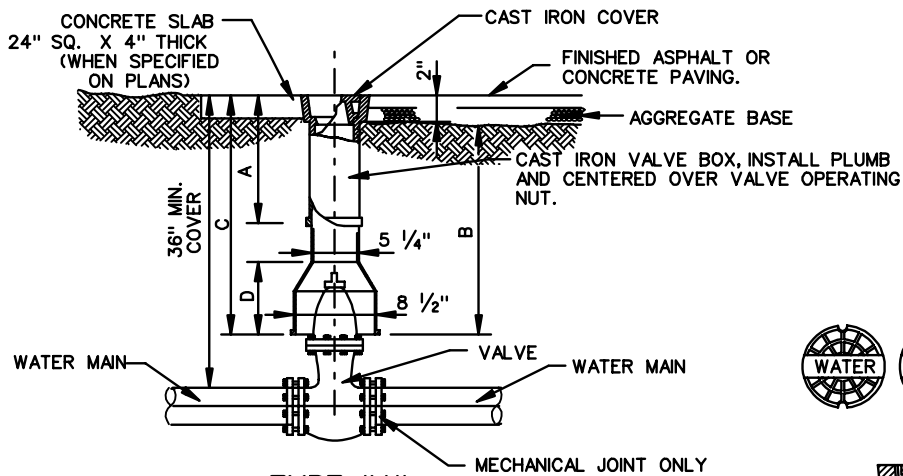

TYPE "A"
(SCREW TYPE)

TYPE "A"

EXTENSION RANGE - C	DIM. A	DIM. B	DIM. D
18"-24"	10.5"	14.5"	6.5"
24"-29"	15"	24"	6.5"
36"-48"	15"	36"	8.5"
36"-60"	26"	36"	8.5"

LONGER BOXES ARE MADE BY ADDING EXTENSIONS.



CAST IRON COVER



CAST IRON VALVE BOX

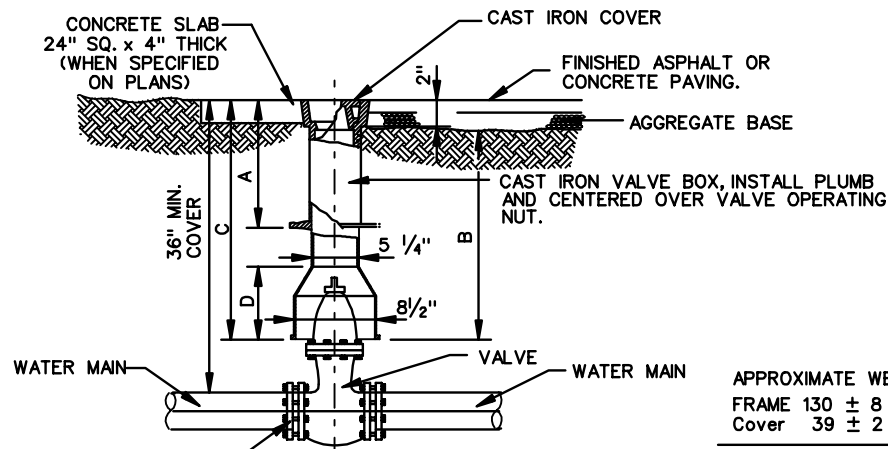

TYPE "B"
(SLIP TYPE)

TYPE "B"

EXTENSION RANGE - C	DIM. A	DIM. B	DIM. D
18"-24"	10.5"	15"	6.5"
23"-29"	15.5"	15"	6.5"
24"-36"	15.5"	24.5"	6.5"
36"-48"	15.5"	26"	8.5"
38"-48"	26.5"	24.5"	6.5"
36"-60"	26.5"	36"	8.5"

LONGER BOXES ARE MADE BY ADDING EXTENSIONS.

APPROXIMATE WEIGHTS
FRAME 130 ± 8 LBS.
Cover 39 ± 2 LBS.

Total 169 ± 10 LBS.

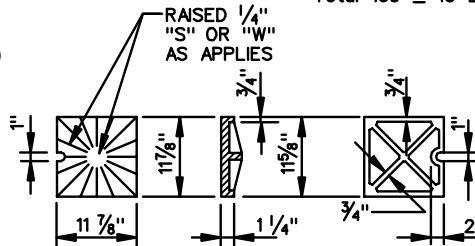

TYPE "C"

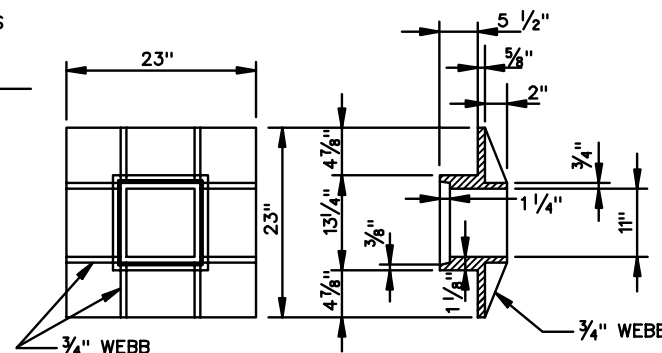

NOTE:

1. CAST IRON SHALL CONFORM TO ASTM A-48M CLASS 30S.

SPECIFICATION REFERENCE

VALVE BOX AND VALVE MANHOLE
(WATER AND SANITARY SEWER FACILITY)

VIRGINIA DEPARTMENT OF TRANSPORTATION



ROAD AND BRIDGE STANDARDS

REVISION DATE

SHEET 1 OF 2

1406.01

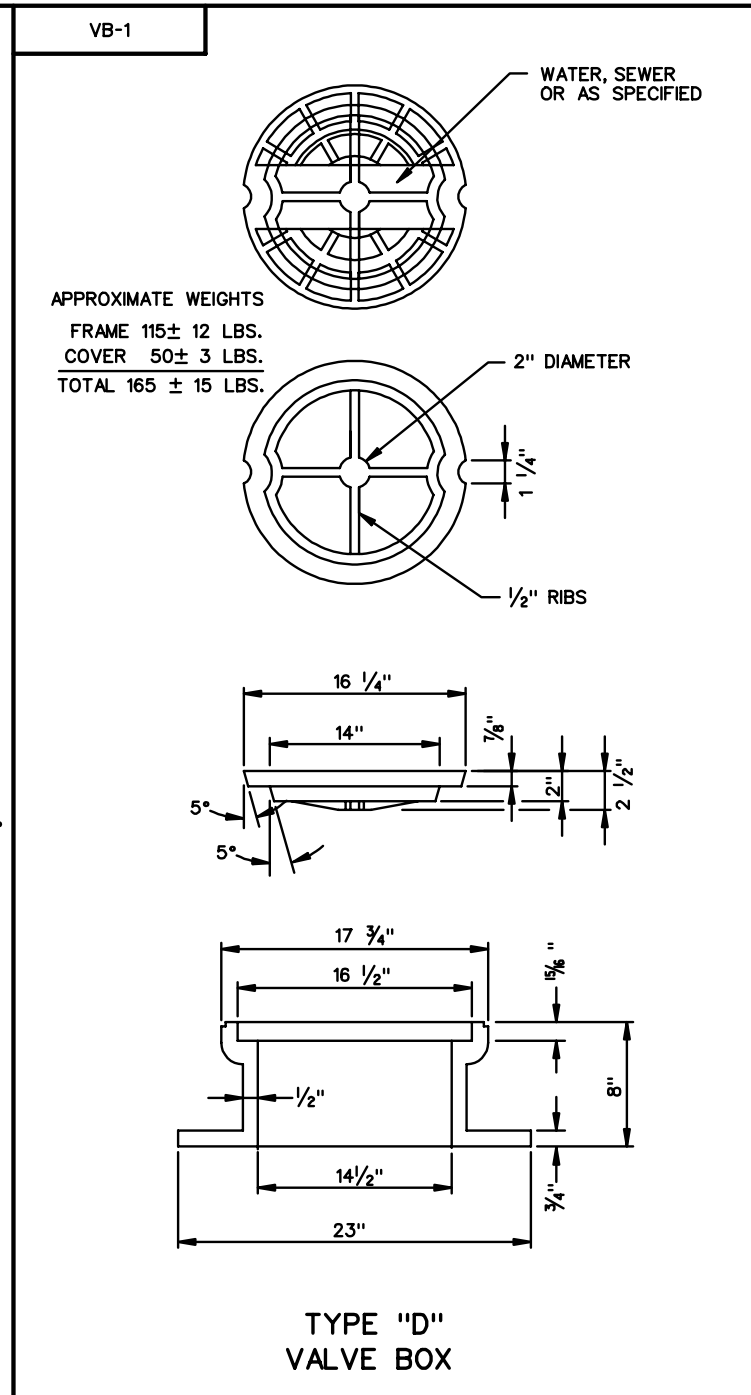
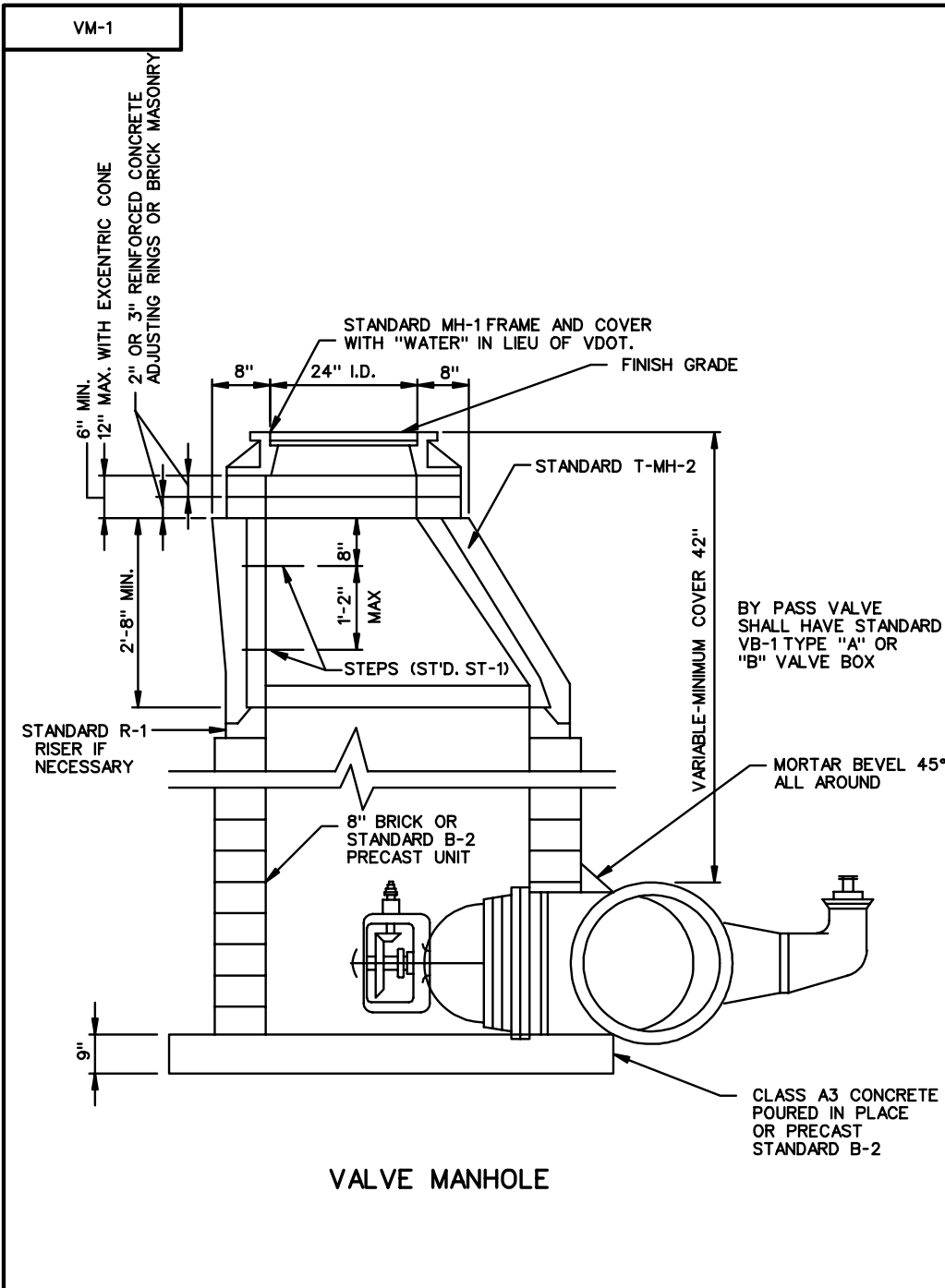

VDOT	
ROAD AND BRIDGE STANDARDS	
SHEET 2 OF 2	REVISION DATE
1406.02	

VALVE BOX AND VALVE MANHOLE
(WATER AND SANITARY SEWER FACILITIES)
VIRGINIA DEPARTMENT OF TRANSPORTATION

SPECIFICATION REFERENCE

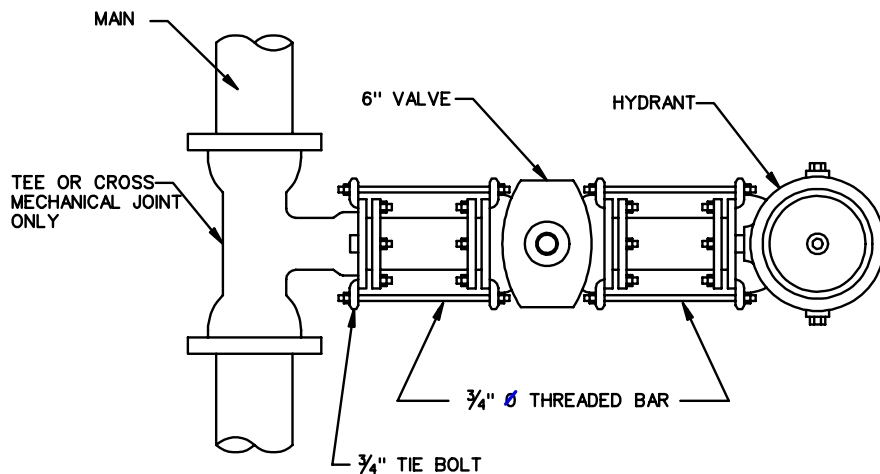

TYPE 1 RESTRAINT

NOTES:

RODS MAY BE INSERTED THROUGH BOLT HOLES IN LIEU OF USING TIE-BOLTS. IF USED, KEEPER NUT & WASHER MUST BE INSTALLED BEHIND GLAND.

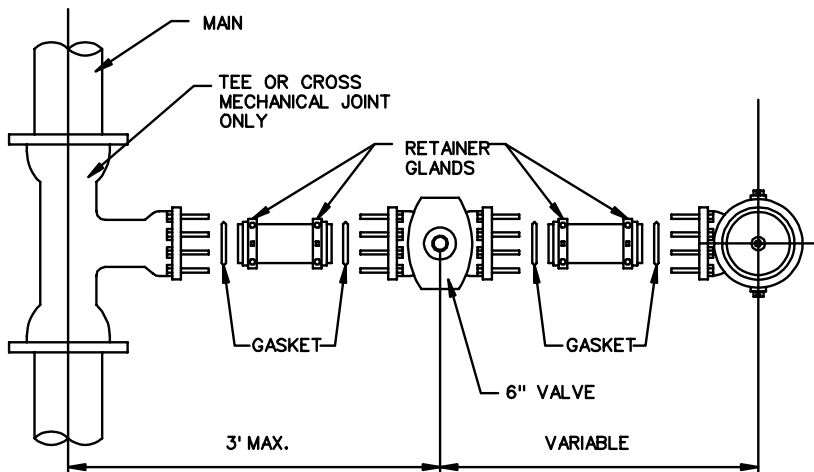

TYPE 2 RESTRAINT

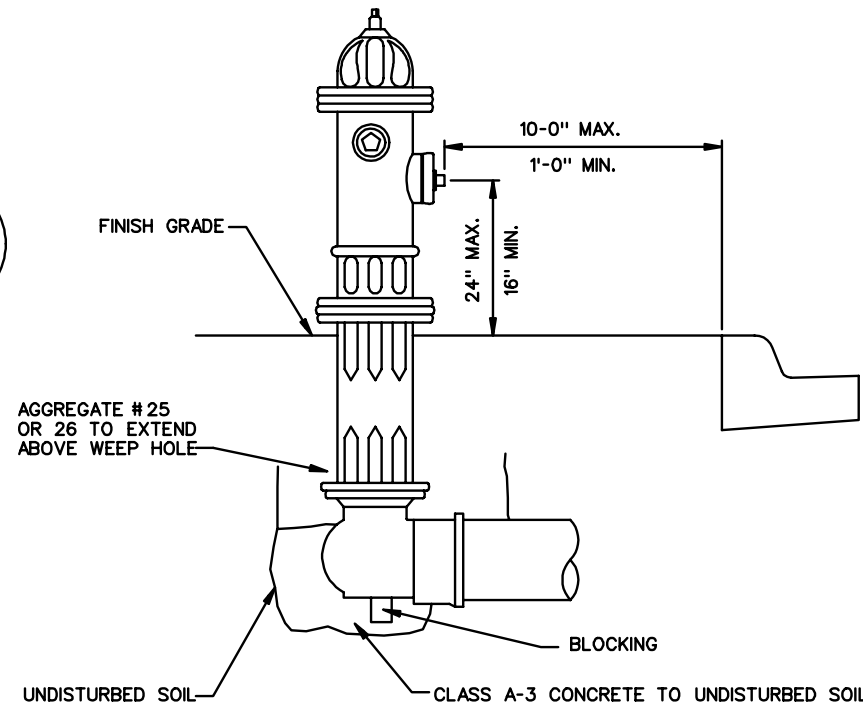

NOTES:

1. HYDRANTS TO BE SET WITH BURY LINE POSITIONED AT GRADE WITH NOZZLES SET AS INDICATED ABOVE.
2. WHEN SET BEHIND CURB THE HOSE NOZZLES ARE TO BE PARALLEL OR AT RIGHT ANGLES TO THE CURB, WITH THE PUMPER NOZZLE FACING THE CURB.
3. BOWL OF THE HYDRANT TO BE BLOCKED AGAINST UNDISTURBED EARTH WITH CLASS A3 CONCRETE OR AS DIRECTED BY THE ENGINEER.
4. FIRE HYDRANTS SHALL HAVE TWO 2 1/2" HOSE NOZZLE AND THE SIZE OF THE PUMPER NOZZLE & TYPE OF OPERATING NUT SHALL BE AS SPECIFIED ON THE PLANS.

SPECIFICATION REFERENCE

FIRE HYDRANT

VIRGINIA DEPARTMENT OF TRANSPORTATION



ROAD AND BRIDGE STANDARDS

REVISION DATE

SHEET 1 OF 1

1407.01

WM-1

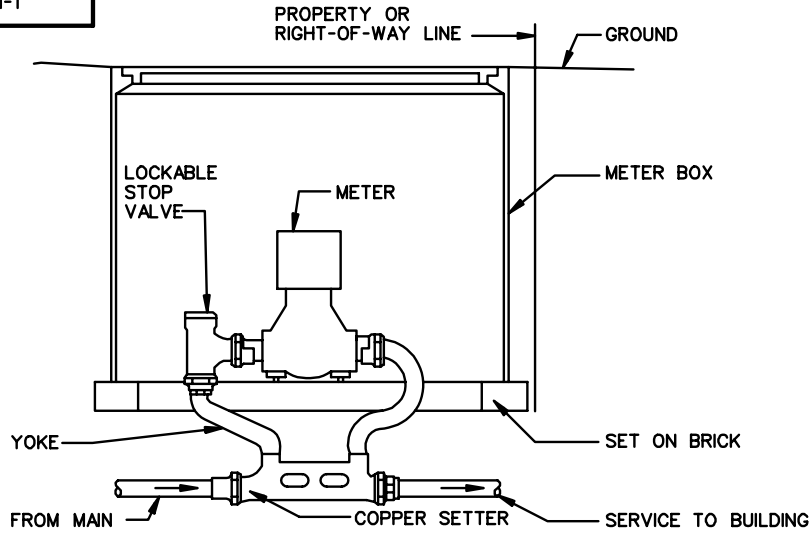

NOTE:

DETAIL IS FOR 5/8" THRU 1" DISC METERS

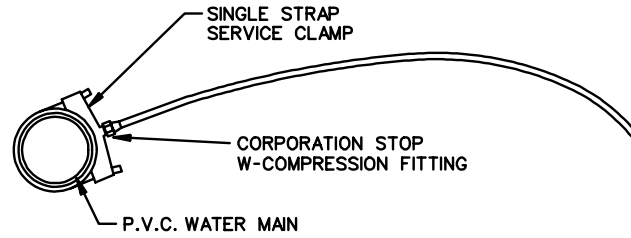

P.V.C. TAP INSTALLATION

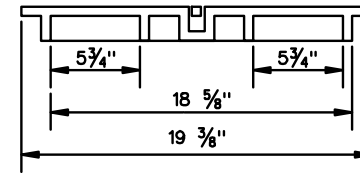

SECTION BB

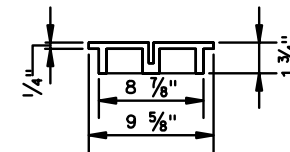

SECTION CC

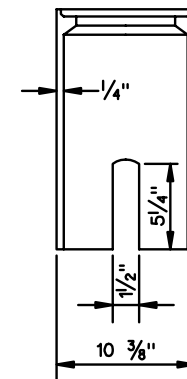

SECTION AA

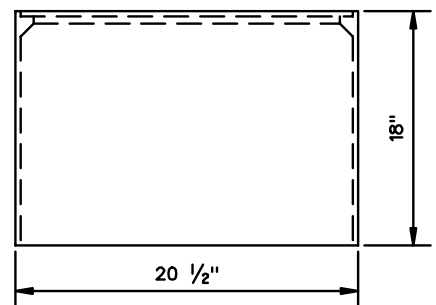
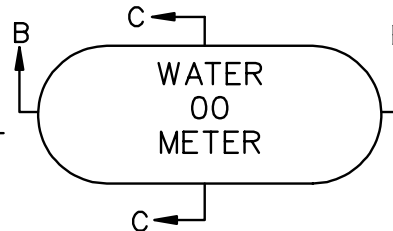
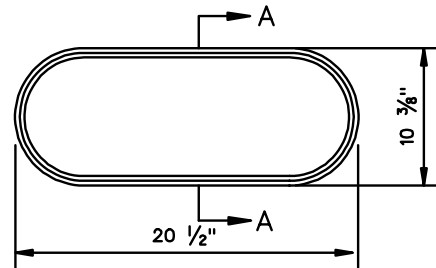

**WATER METER BOX
FOR 5/8" THRU 1" METER**

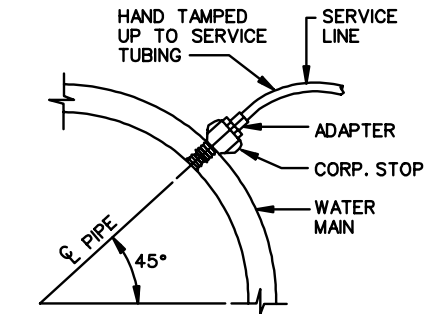

C.I./D.I. TAP INSTALLATION

CAST IRON SHALL CONFORM TO ASTM A-48 CLASS 30S
ALL COPPER FITTINGS SHALL BE FLARED TYPE

VDOT	
ROAD AND BRIDGE STANDARDS	
SHEET 1 OF 1	REVISION DATE
1408.01	

**WATER METER AND BOX
(WATER SERVICE LINES)**

VIRGINIA DEPARTMENT OF TRANSPORTATION

SPECIFICATION
REFERENCE

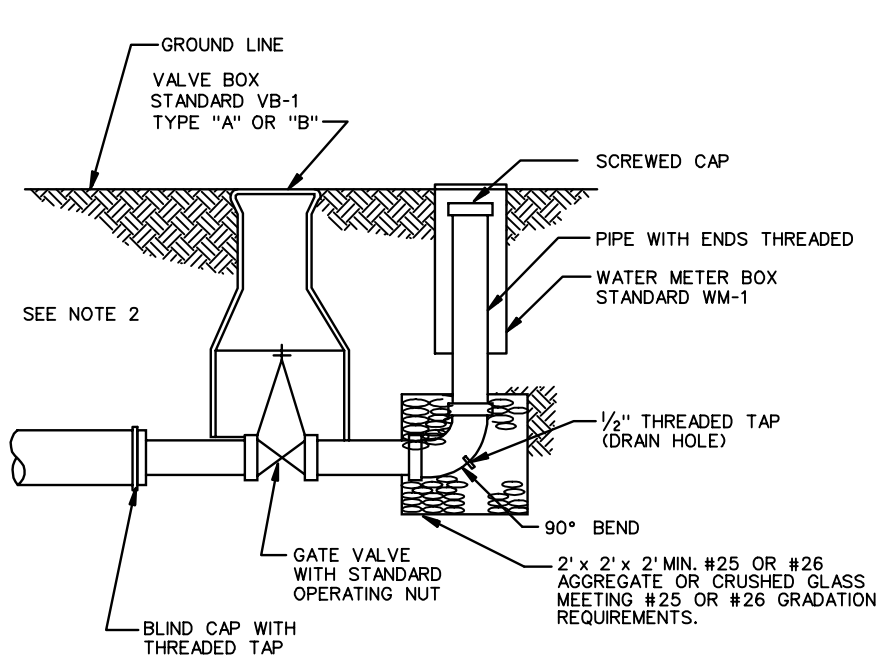

TYPE "A"

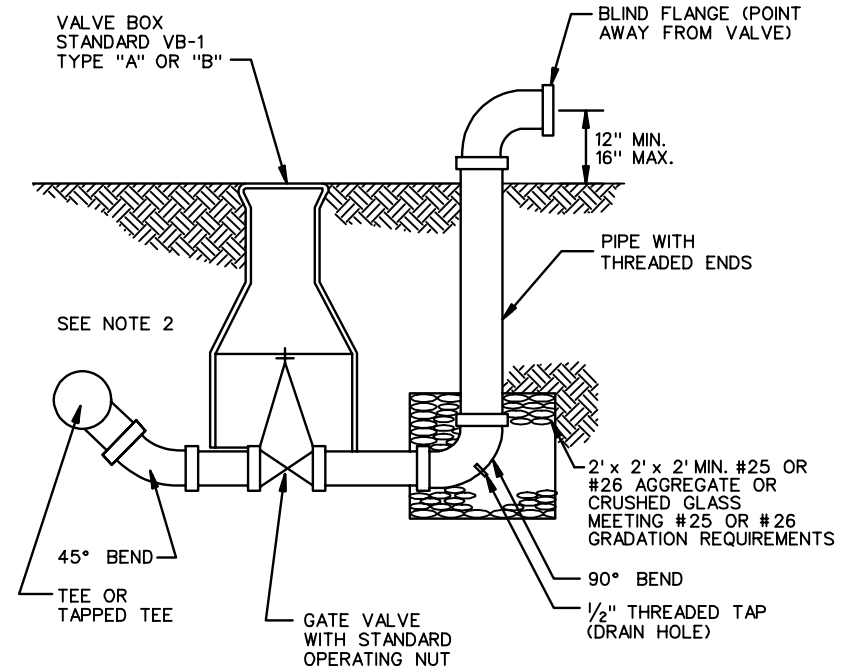

TYPE "B"

NOTES:

1. ALL BLOW-OFFS SHOULD BE PLACED IN A POSITION TO ASSURE NATURAL DRAINAGE.
2. EITHER TYPE "A" OR TYPE "B" BLOW-OFF MAY BE USED AT DEAD OR SAG SITUATION.
3. BLOW-OFF PIPE SHALL BE THREADED BLACK IRON OR GALVANIZED STEEL PIPE.
4. SIZE OF BLOW-OFF SHALL BE SPECIFIED ON THE PLANS.

SPECIFICATION REFERENCE

BLOW-OFF VALVE AND BOX
(WATER AND SANITARY SEWER FACILITIES)

VIRGINIA DEPARTMENT OF TRANSPORTATION



ROAD AND BRIDGE STANDARDS

REVISION DATE

SHEET 1 OF 1

1409.01

ARV-1

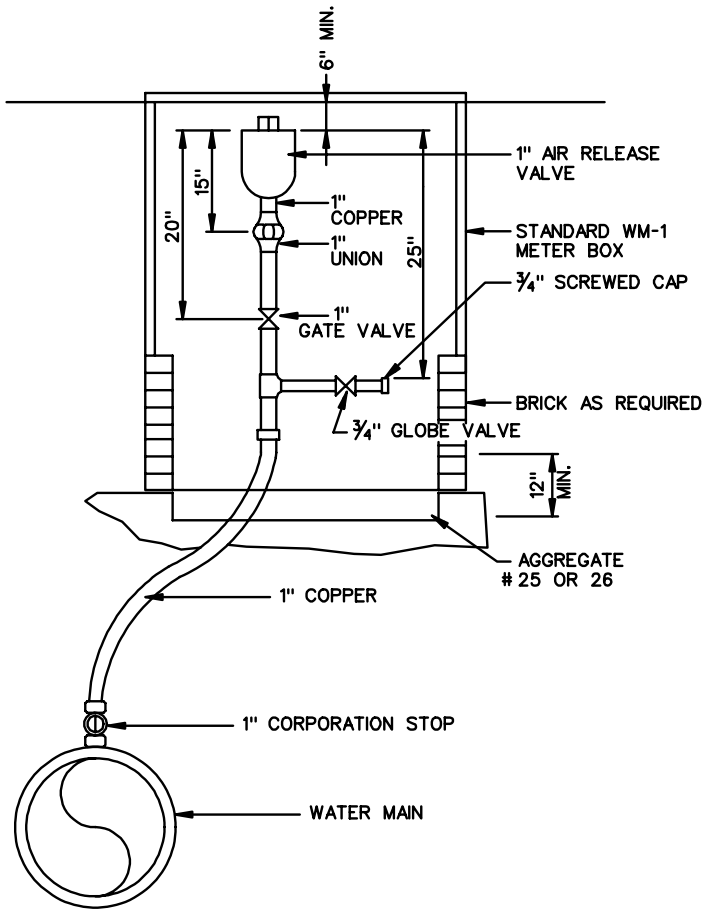

TYPE "A"

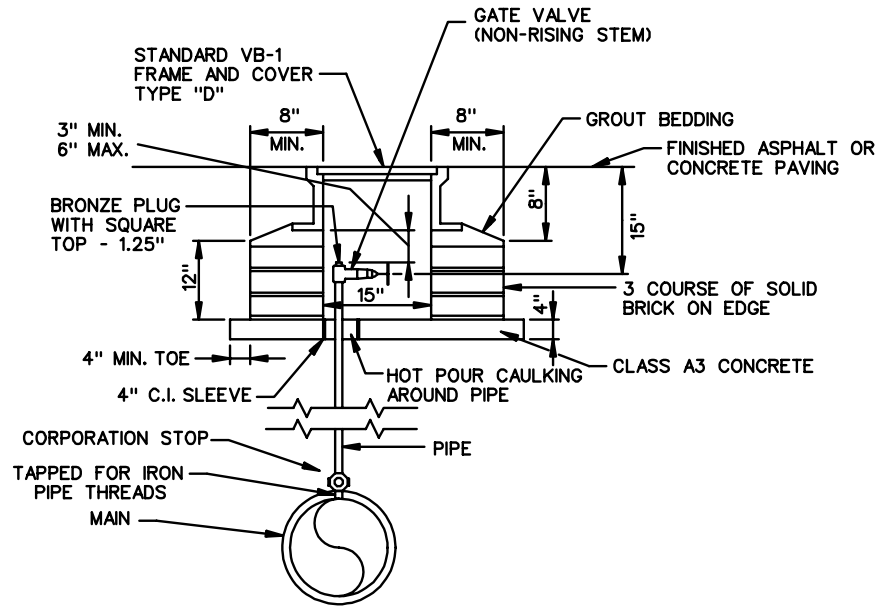

TYPE "B"

NOTES:

1. TAP FOR AIR RELEASE VALVE SHALL BE STANDARD THREADED TAP OR SADDLE TAP DEPENDING ON MANUFACTURER'S RECOMMENDATION FOR TYPE AND THICKNESS OF PIPE ENCOUNTERED.
2. GRAVEL BEDDING MAY BE USED IN PLACE OF CONCRETE IN NON-TRAFFIC AREAS AT DESCRETION OF ENGINEER.
3. PIPE SHALL BE BLACK IRON / GALVANIZED PIPE.
4. IF 4" OR 6" PVC PIPE IS USED, SADDLE IS REQUIRED FOR CORPORATION STOP.
5. ALL COPPER FITTINGS WILL BE FLARE TYPE.



ROAD AND BRIDGE STANDARDS

SHEET 1 OF 1

REVISION DATE

1410.01

AIR RELEASE VALVE AND BOX
(WATER AND SANITARY SEWER FACILITIES)

VIRGINIA DEPARTMENT OF TRANSPORTATION

SPECIFICATION
REFERENCE

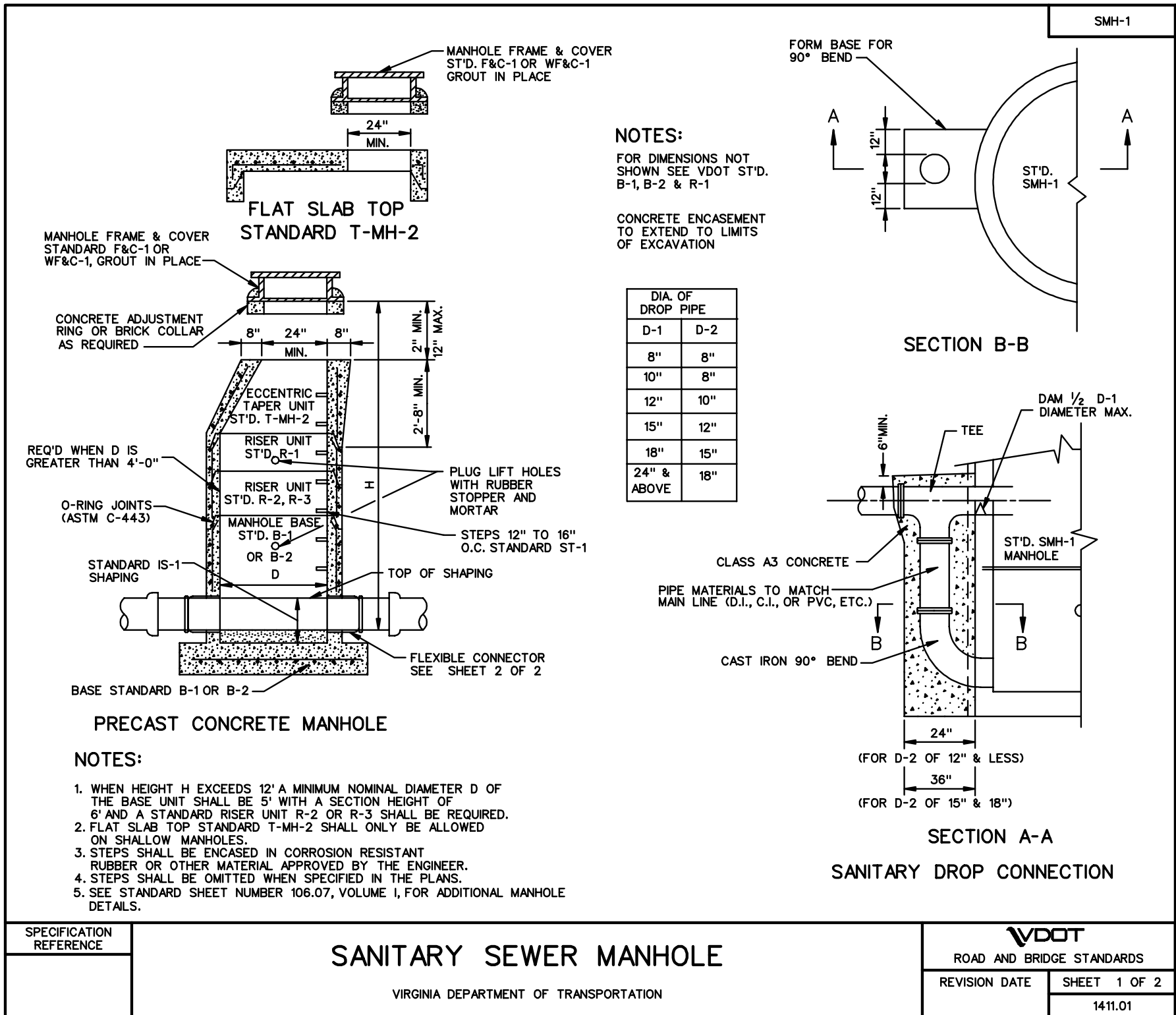

SPECIFICATION REFERENCE

SANITARY SEWER MANHOLE

VIRGINIA DEPARTMENT OF TRANSPORTATION



ROAD AND BRIDGE STANDARDS

REVISION DATE

SHEET 1 OF 2

1411.01

SMH-1

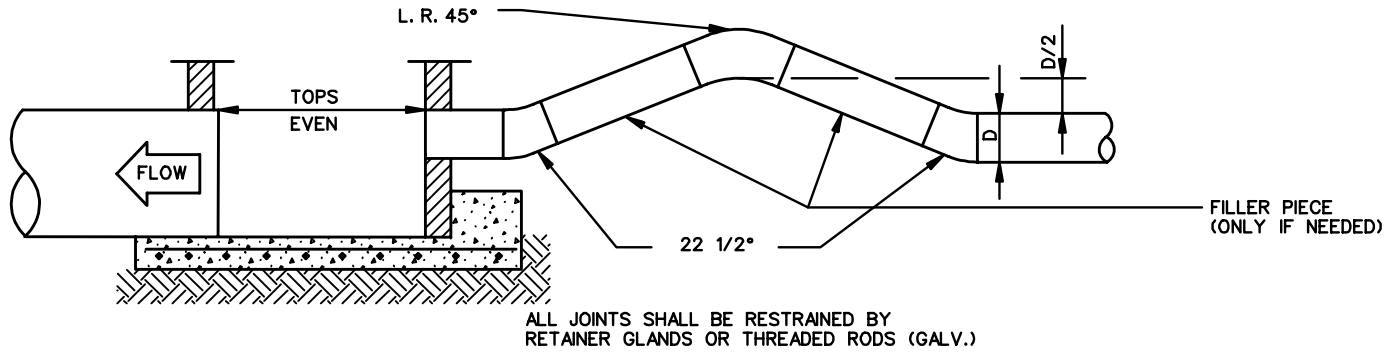

**FORCE MAIN DISCHARGE
TYPE 1**

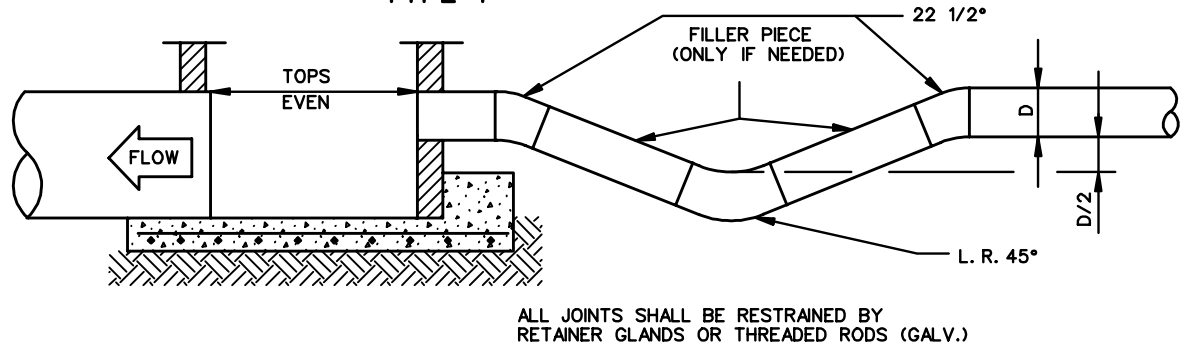

**FORCE MAIN DISCHARGE
TYPE 2**

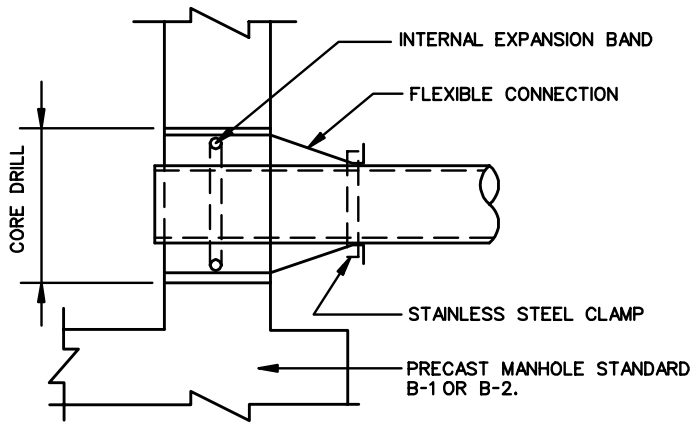

FLEXIBLE CONNECTION

PIPE TO PRECAST MANHOLE CONNECTIONS SHALL BE MADE WITH A FLEXIBLE BOOT. THE BOOT SHALL MEET ASTM SPECIFICATION C-923 AND CONSIST OF NEOPRENE RUBBER, EPDM RUBBER, OR POLYISOPRENE RUBBER, WHERE PREFERENCE MAY BE GIVEN TO A CERTAIN MATERIAL IN PROJECT SPECIFIC INSTANCES. THE INTERNAL EXPANSION BAND TO SECURE THE BOOT IN PLACE SHALL BE COMPOSED OF STAINLESS STEEL OR A NON-METALLIC MATERIAL. THE EXTERNAL BAND TO CLAMP AND SEAL THE BOOT TO THE PIPE SHALL BE CORROSION RESISTANT STAINLESS STEEL CONFORMING TO ASTM SPECIFICATION A-167. THE PORT TO RECEIVE THE BOOT SHALL BE CORE DRILLED AND SHOULD BE MANUFACTURED TO ALLOW FOR LATERAL AND VERTICAL MOVEMENT. ALL FIELD INSTALLATION OF PIPE THRU MANHOLE SEAL SHALL BE DONE IN ACCORDANCE WITH THE MANUFACTURER'S RECOMMENDATIONS AND SPECIFICATIONS.



ROAD AND BRIDGE STANDARDS

SHEET 2 OF 2

REVISION DATE

1411.02

**SANITARY SEWER MANHOLE
WATER AND SANITARY SEWER FACILITIES**

VIRGINIA DEPARTMENT OF TRANSPORTATION

SPECIFICATION
REFERENCE

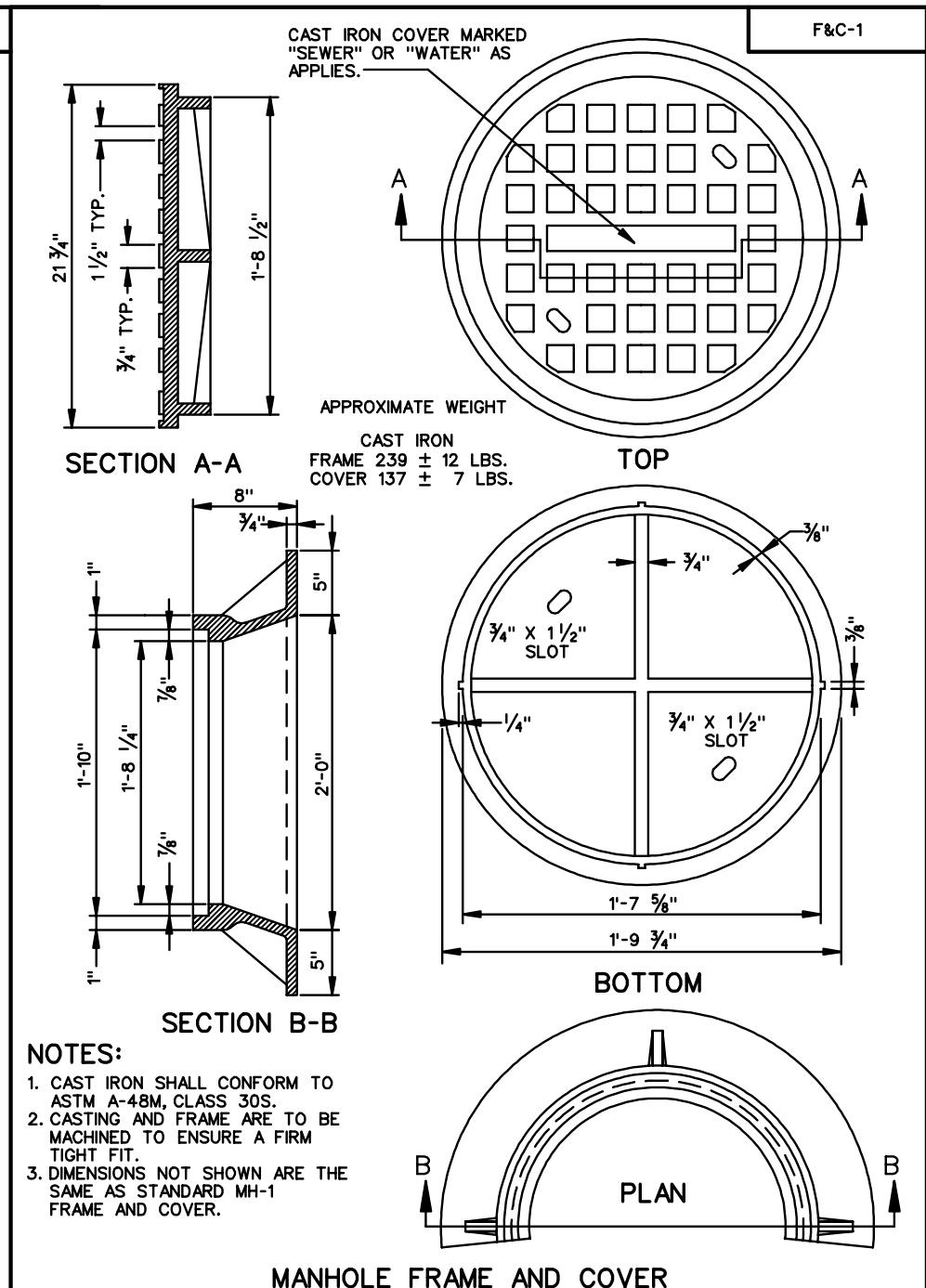
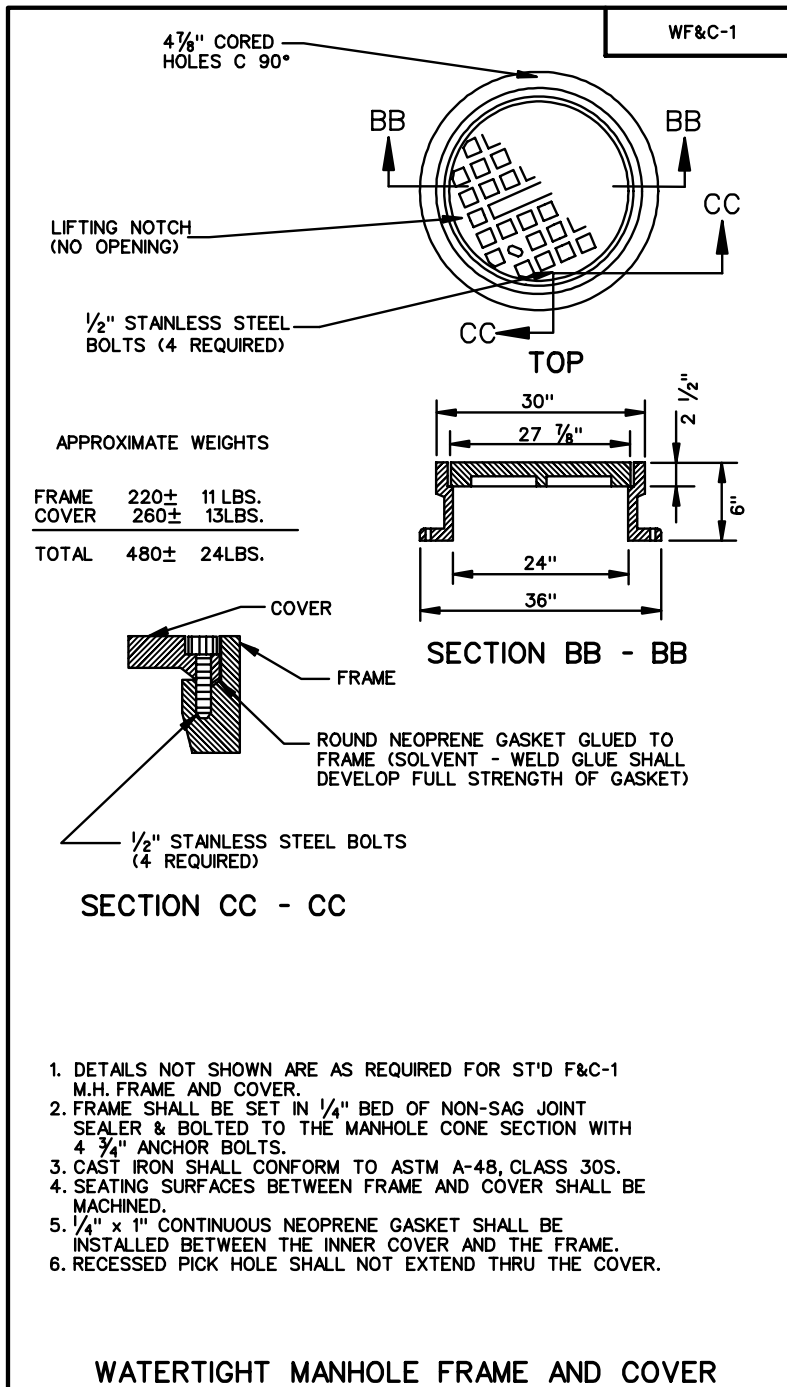

SCO-1

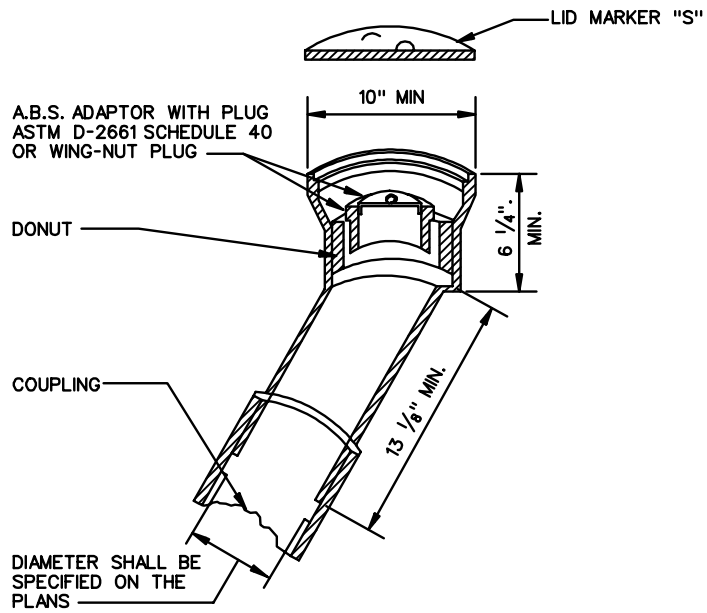

NOTES:

1. CLEANOUT MAY ALSO BE INSTALLED WITH IRON BODY SCREW WITH BRASS PLUG AND ONE INCH OF LEAD POURED IN PLACE & CAULKED ON INSIDE & OUTSIDE EDGE.
2. CLEANOUT SHALL BE SUITABLY BRACED WITH 2" x 4" CROSS PIECE EXTENDED OVER & HAVING SOLID BEARING AT LEAST ONE FOOT ON EACH SIDE OF DITCH
3. CLEANOUT WYE AND RISER SHALL BE CONSTRUCTED OF THE SAME MATERIAL AS THE MAIN UNLESS OTHERWISE SPECIFIED.

TYPE "A"

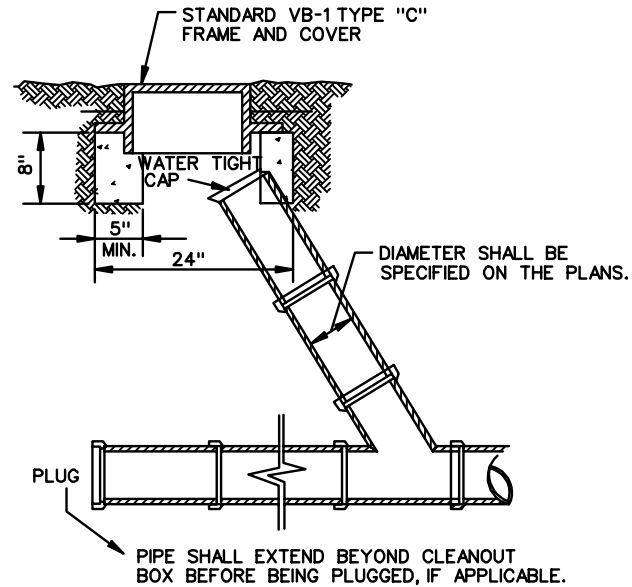

NOTES:

1. CAST IRON FRAME AND COVER SHALL BE SUFFICIENTLY TRUE TO A PLANE SURFACE, SO THAT TOPS WILL NOT ROCK.
2. CLEANOUT WYE AND RISER SHALL BE CONSTRUCTED OF THE SAME MATERIALS AS THE MAIN UNLESS OTHERWISE SPECIFIED.

TYPE "B"



ROAD AND BRIDGE STANDARDS

SHEET 1 OF 1

REVISION DATE

1413.01

SEWER CLEANOUT

VIRGINIA DEPARTMENT OF TRANSPORTATION

SPECIFICATION REFERENCE