

For Truck Apron Curb use cell Mod. CG-3 found in the cell library.*

CG-3 MODIFIED

FOR USE ON ROUNDABOUT TRUCK APRONS ONLY

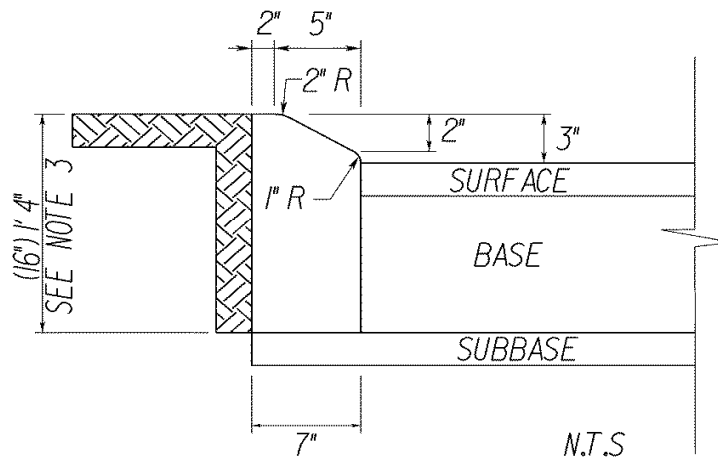

NOTES:

1. THIS ITEM MAY BE PRECAST OR CAST IN PLACE.
2. CONCRETE TO BE CLASS A3 IF CAST IN PLACE, 4000 PSI IF PRECAST.
3. THE DEPTH OF CURB MAY BE REDUCED AS MUCH AS 3" (13" DEPTH) OR INCREASED AS MUCH AS 3" (19" DEPTH) IN ORDER THAT THE BOTTOM OF THE CURB WILL COINCIDE WITH THE TOP OF A COURSE OF THE PAVEMENT'S SUBSTRUCTURE. OTHERWISE, THE DEPTH IS TO BE 16" AS SHOWN. NO ADJUSTMENT IN THE PRICE BID IS TO BE MADE FOR A DECREASE OR AN INCREASE IN DEPTH.
4. THE MODIFICATION TO THE STANDARD CG-3 IS TO REDUCE THE EXPOSED HEIGHT OF THE CURB AS SHOWN. MODIFIED CURB SHALL BE PAID FOR AS STANDARD CG-3.